

DEUTSCH MIT SPASS

Учебник немецкого языка для 1-класса

*Утверждено
Министерством народного образования
Республики Узбекистан*



Издательско-полиграфический творческий дом
имени Гафура Гуляма
Ташкент – 2019

УДК 811.112.2 (075)
КБК 81.2 Нем
Д 32

Манзура Дадаходжаева, Зухра Нарбекова, Арзигуль Мирсалимова,
Рената Файзулина, Дилбар Таджибаева, Танзиля Гафурова,
Наталья Суханова, Алла Беканачева, Лутфулла Холияров

Рецензенты:

Свен Шрёдер – координатор Центра Германской внешней методической помощи школам.

Герт Вегмарсхаус – доктор, лектор GAOX (DAAD).

Юсуф Исмаилов – доцент УзГУМЯ, к.ф.н.

Татьяна Некрасова – директор школы № 60 с углубленным изучением немецкого языка Мирабадского района города Ташкента.

Ответственный редактор

Рахимов Х.Р – профессор ТГПУ им. Низами

Учебно-методический комплекс “Deutsch mit Spaß” подготовлен к изданию согласно Постановлению Президента Республики Узбекистан ПП – 1875 от 10 декабря 2012 года «О мерах по совершенствованию системы изучения иностранных языков». Данный учебник создан для учеников 1-го класса на основе нового подхода к изучению немецкого языка с учётом всех требований и поставленных задач в постановлении, а также в соответствии с утверждённым Государственным стандартом образования Узбекистана и требованиями CEFR.

Учебник 1-го класса направлен непосредственно на развитие разговорной речи в форме игровых уроков и устного восприятия без чтения и письма. Задания в учебнике выполняются под руководством учителя.

УДК 811.112.2 (075)
КБК 81.2 Нем



Verbinde



Hör



Schau mal



Spiel



Sprich nach



Spiel Minidialoge



Mal aus



Zeichne



Singe



Probiere aus



Finde heraus



Schneide aus



Puzzle

ISBN 978-9943-5549-7-9

© М. Дадаходжаева и др.
© Издательско-полиграфический
творческий дом имени
Гафура Гуляма, 2019



Дорогие учителя и родители!

Вашему вниманию предлагается учебно-методический комплекс «Deutsch mit Spaß».

Учебно-методический комплекс подготовлен и создан в соответствии с новыми требованиями и поставленными задачами. Изучение немецкого языка без алфавита, на основе новых современных технологий и методических принципов обучения это совершенно новый метод подхода к изучению языка, который ещё не наблюдался в мировой практике.

Учебно-методический комплекс включает в себя учебник для учеников первого класса, «Учебно-методическое пособие» для учителей, Multimedia CD, а также состоит из множества интересных, разнообразных и познавательных упражнений, стихотворений, игр, с помощью которых можно познать азы немецкого языка. Задача учителей и родителей заключается в том, чтобы довести всё это до сознания наших детей.

Метод обучения в 1-ом классе немецкому языку без чтения и письма с помощью игр является новшеством в истории обучения языку и впервые практикуется в нашем государстве. И поэтому в учебнике могут быть допущены некоторые погрешности.

В связи с этим ваши мнения и предложения для нас – авторов будут очень ценными и полезными.

Авторы



BEKANNTSCHAFT

Begrüßung



1. Schau mal.

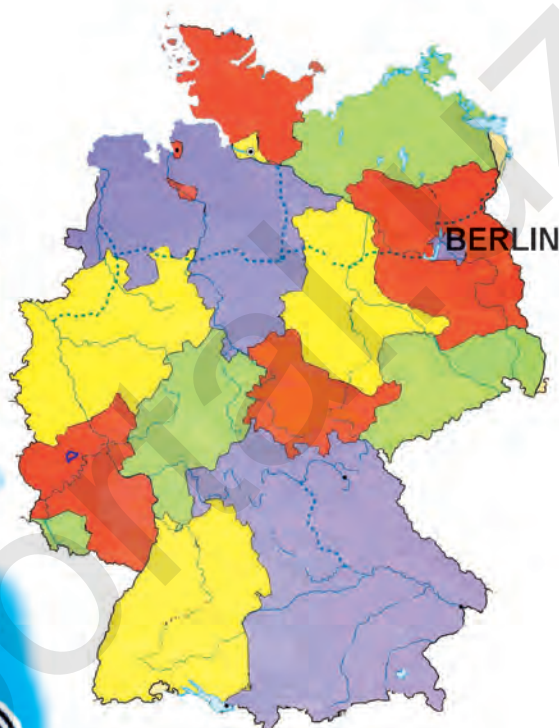

2. Hör den Reim.



3. Puzzle.



BEKANNTSCHAFT

Begrüßung



4. Mal aus.





BEKANNTSCHAFT

Guten Morgen!



5. Spiel mit dem Würfel.

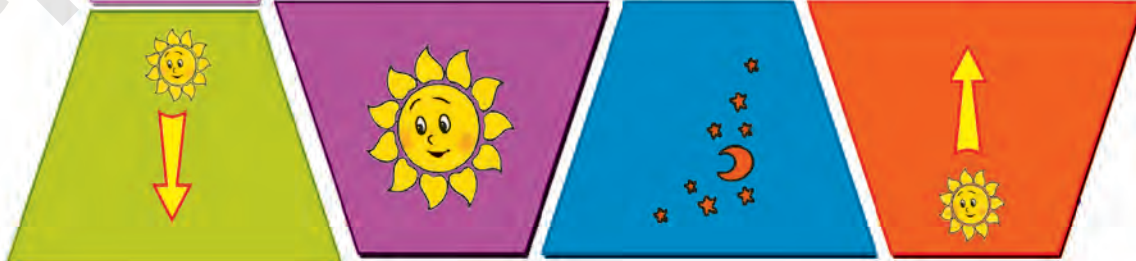
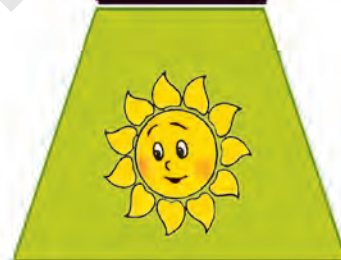
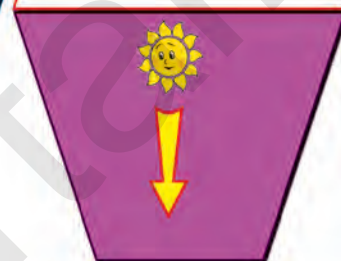

BEKANNTSCHAFT

Guten Morgen!



6. Verbinde und mal aus.

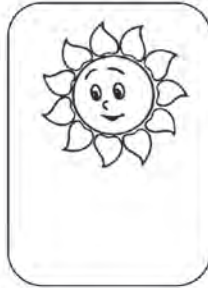
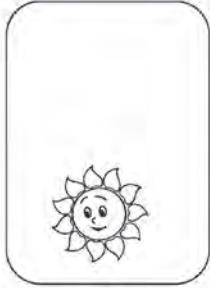



BEKANNTSCHAFT

Sich verabschieden (Tschüss)



7. Hör und sprich nach.



8. Spiel Minidialoge und variiere.

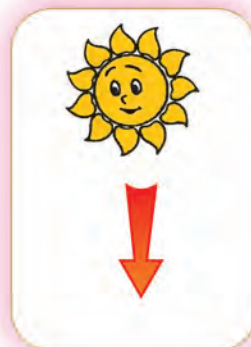
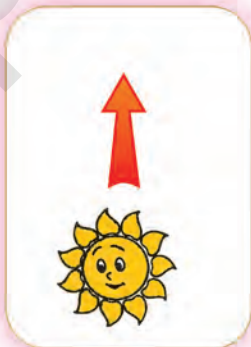

BEKANNTSCHAFT

Sich verabschieden

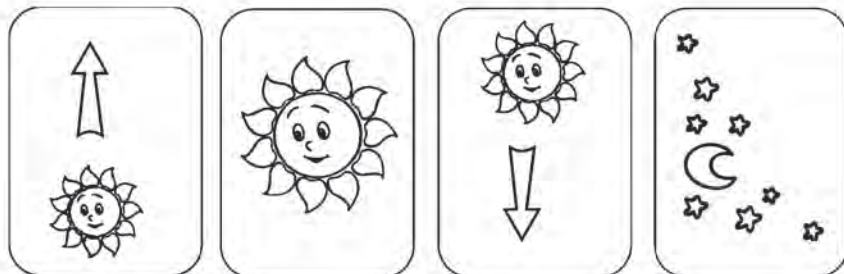

9. Mal aus.





BEKANNTSCHAFT

Wie geht es?



10. Singe.



11. Hör, sprich nach und variiere.



ALLES ÜBER MICH

Sich vorstellen



1. Hör und sprich nach.



2. Spiel Minidialoge.





ALLES ÜBER MICH

Sich vorstellen



3. Schau mal und mal aus.

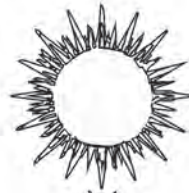
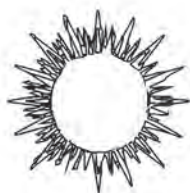

ALLES ÜBER MICH

Ich bin ...

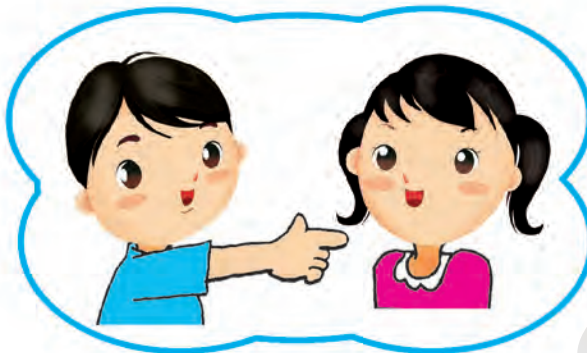

4. Schau mal und sprich.

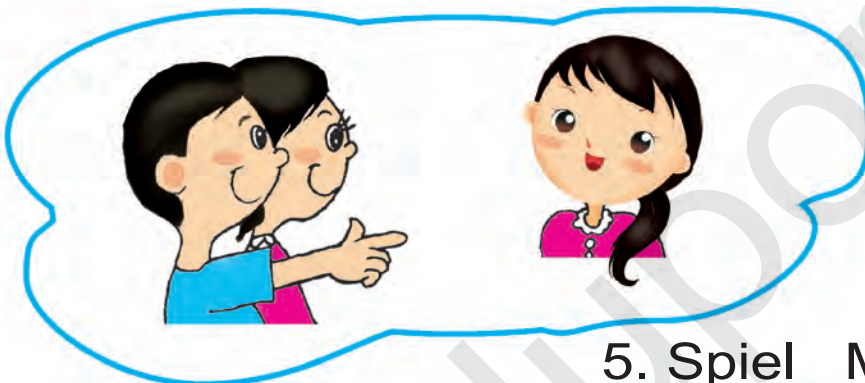

5. Spiel Minidialoge.





ALLES ÜBER MICH

Ich bin ...



6. Mal aus und sprich.

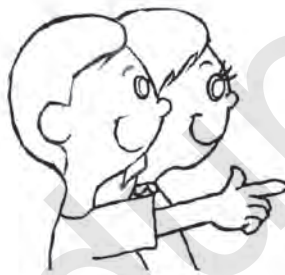
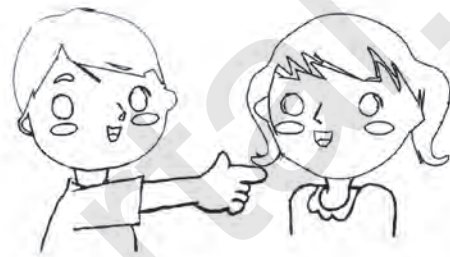

ALLES ÜBER MICH

Wie alt bist du?



7. Hör und sprich nach.



8. Spiel Minidialoge.





ALLES ÜBER MICH

Wo wohnst du?



9. Schau mal.



10. Sprich.



FAMILIE

Eine Familie stellt sich vor



1. Hör zu.



2. Sprich nach.



3. Singe mit.





FAMILIE

Eine Familie stellt sich vor



4. Spiel mit.



FAMILIE

Das ist mein ...
Das ist meine ...



5. Sprich nach.



6. Hör und wiederhole.



7. Singe mit.





FAMILIE

Das ist mein ...



8. Spiel.



9. Mal aus und sprich nach.

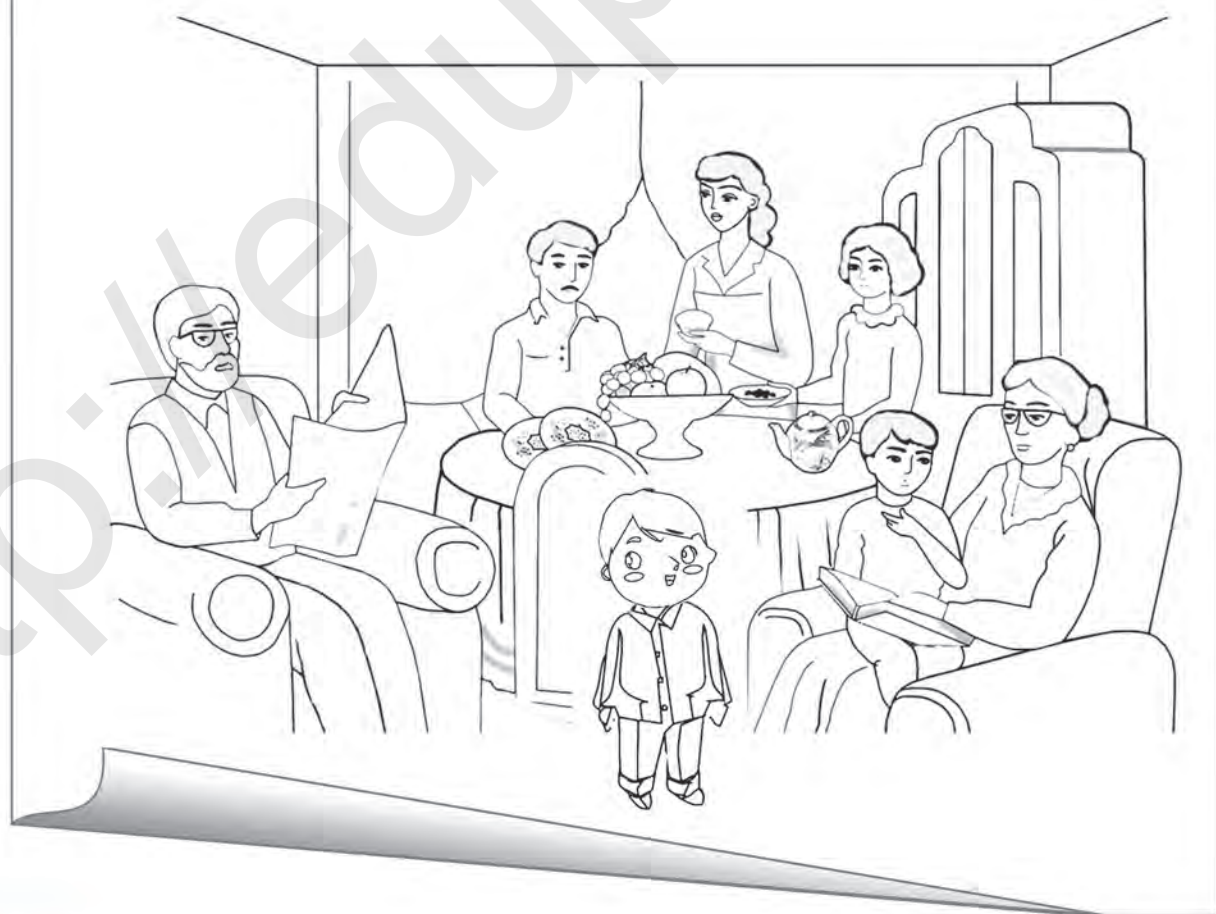

FAMILIE

Unsere Familie ist ...



10. Singe mit.



11. Spiel.

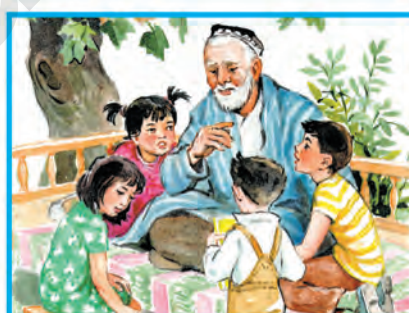

12. Spiel Minidialoge.





FAMILIE

Meine Familie



13. Singe mit.



14. Spiel mit.



15. Sprich nach.



MEIN FREUND

Mein Freund / meine Freundin
heißt ...

4



1. Sprich.



2. Spiel Minidialoge.



3. Hör.





MEIN FREUND

Mein Freund / meine Freundin heißt ...



4. Mal aus.



5. Sprich.



MEIN FREUND

Mein Freund ist ...



6. Singe mit.



7. Sprich nach.



8. Spiel Minidialoge.





MEIN FREUND

Mein Freund ist ...



9. Mal aus.



10. Spiel.



11. Sprich.



MEIN FREUND

Wohnort



12. Sprich.



13. Hör Minidialoge.



14. Spiel Minidialoge.





MEIN FREUND

Mein Freund spricht ...



15. Spiel.

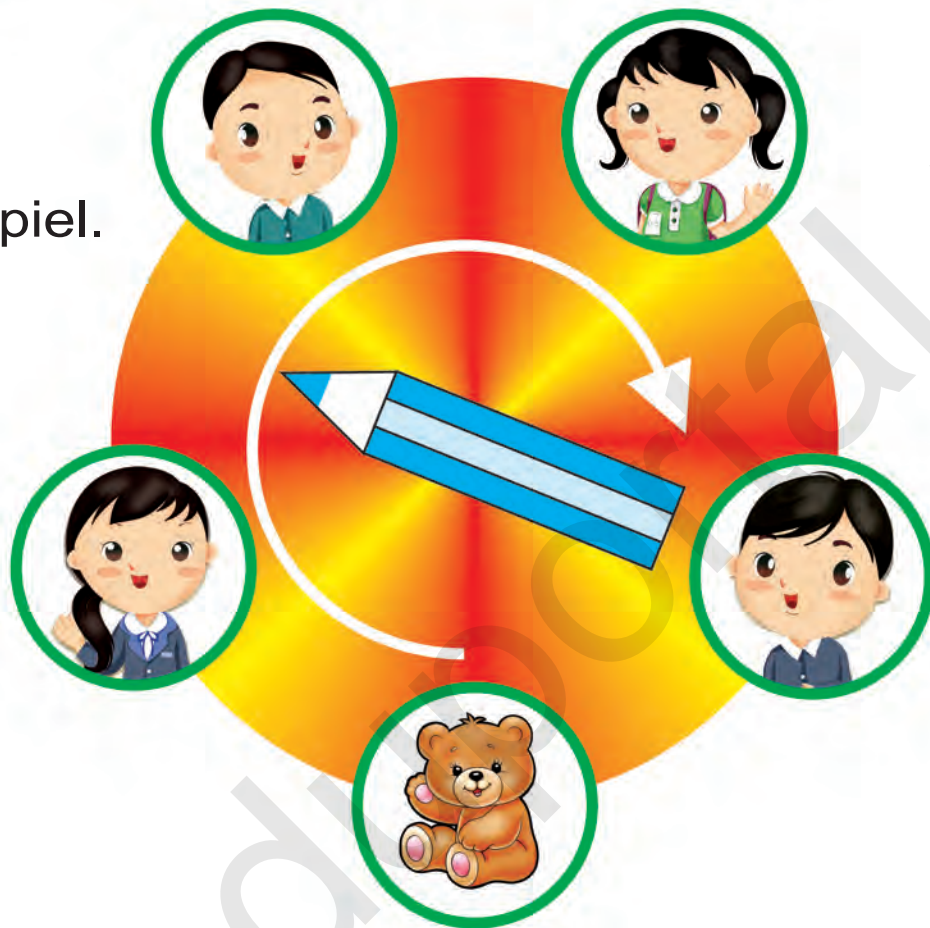

WIEDERHOLUNG



16. Zeichne deinen Freund.

17. Erzähle von ihm.

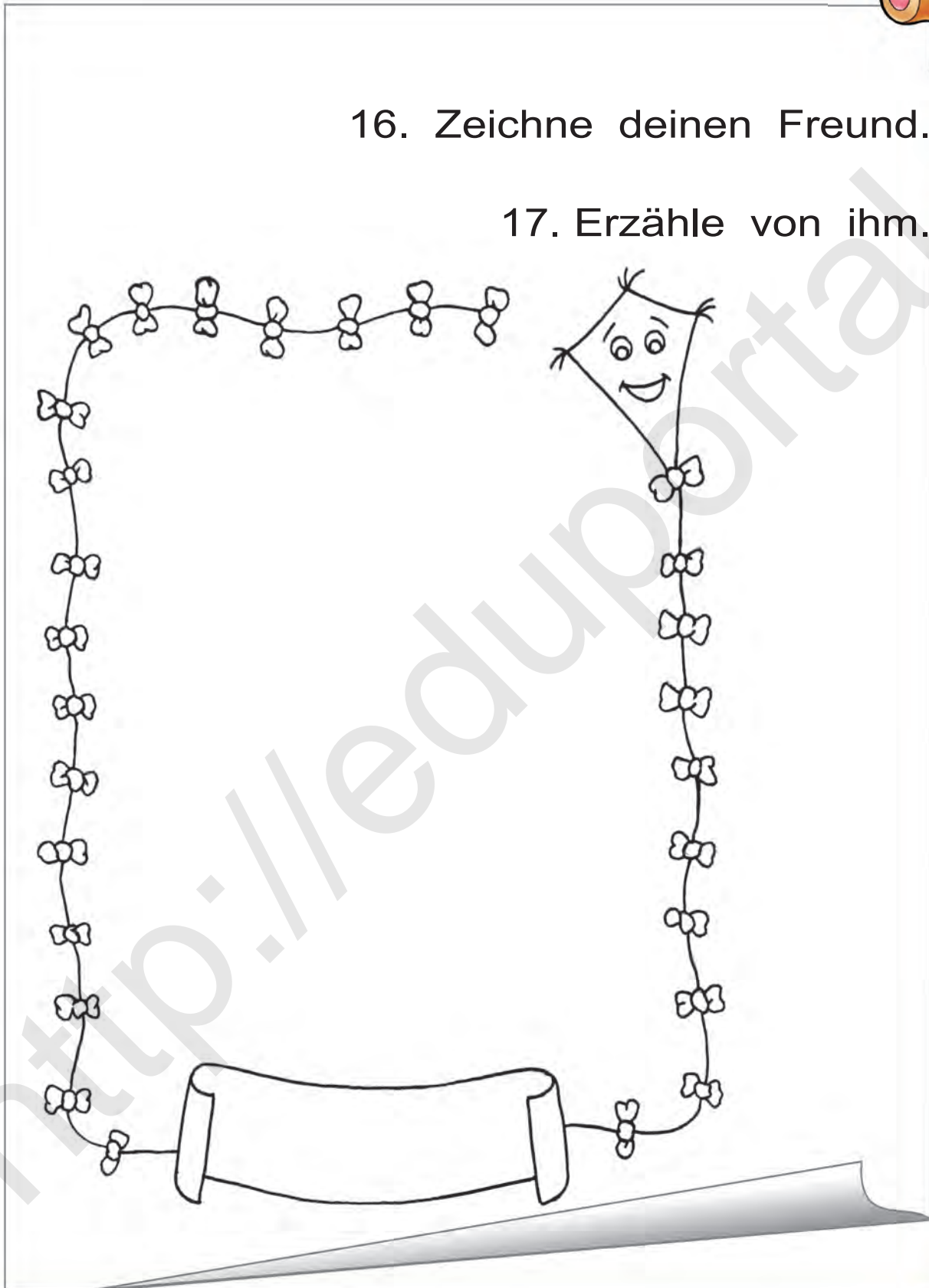



FARBEN

Welche Farben sind das?



1. Hör.



2. Spiel.



3. Probiere aus.



FARBEN

Welche Farben sind das?



4. Verbinde.



5. Mal aus.



6. Probiere aus.





FARBEN

Gegenstände und Farben



7. Spiel und verbinde.



8. Sprich.



9. Mal aus.

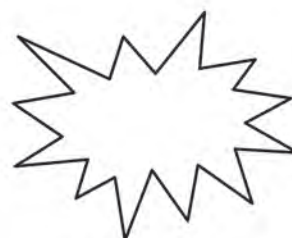
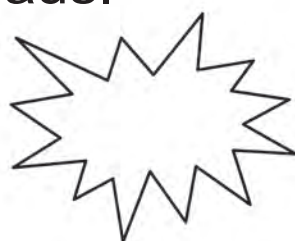

FARBEN

Gegenstände und Farben



10. Hör und mal aus.

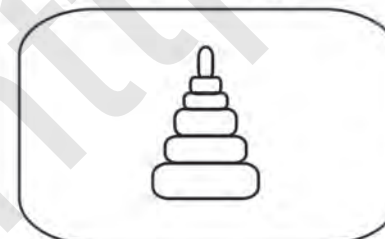
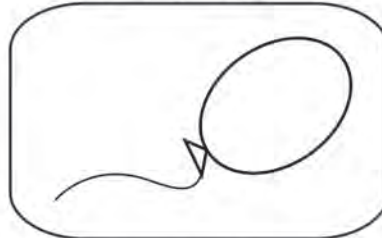
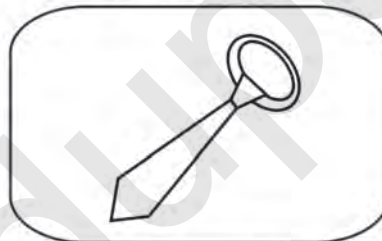
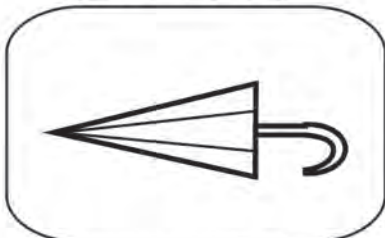
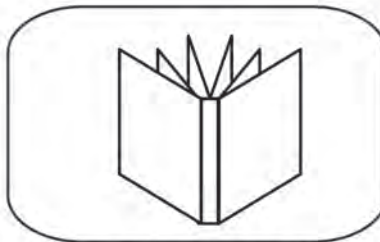



FARBEN

Gegenstände und Farben



11. Sprich.



12. Spiel.

			
			
			
			
			
			

FARBEN

Farben und Formen



13. Hör und sprich nach.

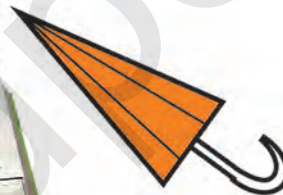

14. Mal aus.





SPIELZEUGE

Mein Spielzeug ist ...



1. Spiel.



2. Hör und sprich nach.



3. Verbinde.



SPIELZEUGE

Mein Spielzeug ist ...

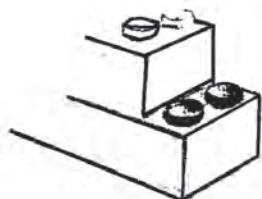

4. Zeichne weiter.



5. Nenne die Spielzeuge.

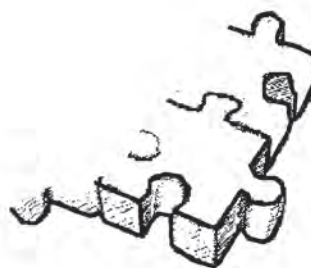



SPIELZEUGE

Spielzeuge und Farben



6. Sprich nach.



7. Spiel.

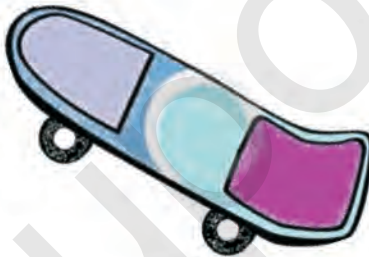

8. Verbinde.



SPIELZEUGE

Spielzeuge und Farben



9. Mal aus und finde die Spielzeuge



10. Nenne die Spielzeuge.





SPIELZEUGE

Ich spiele gern ...



11. Was spielst du gern? Zeichne und markiere.



12. Nenne und spiel.

WIEDERHOLUNG



13. Zeichne deine Lieblingsspielzeuge.



14. Mal aus.





SPIELZEUGE

Hier sind ...



15. Zähle.

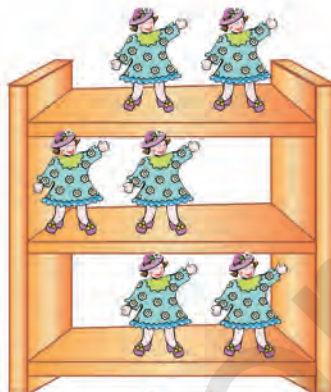
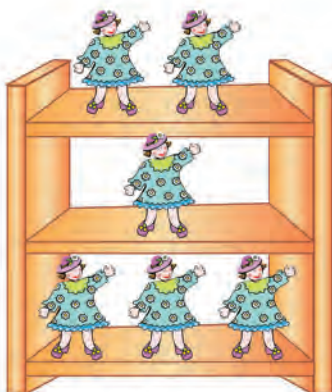

16. Zeichne die Zahl.

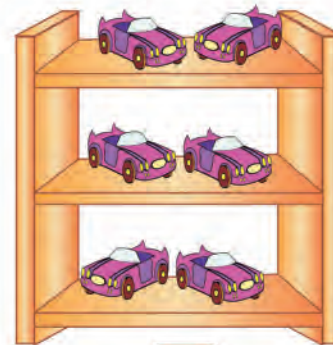
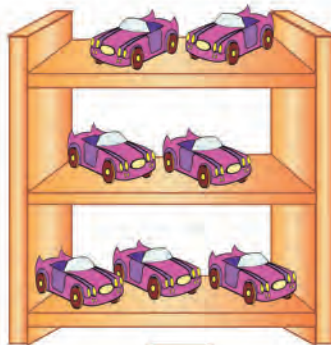
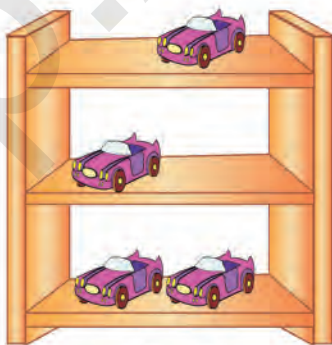

UMWELT

Bekanntschaft mit Natur

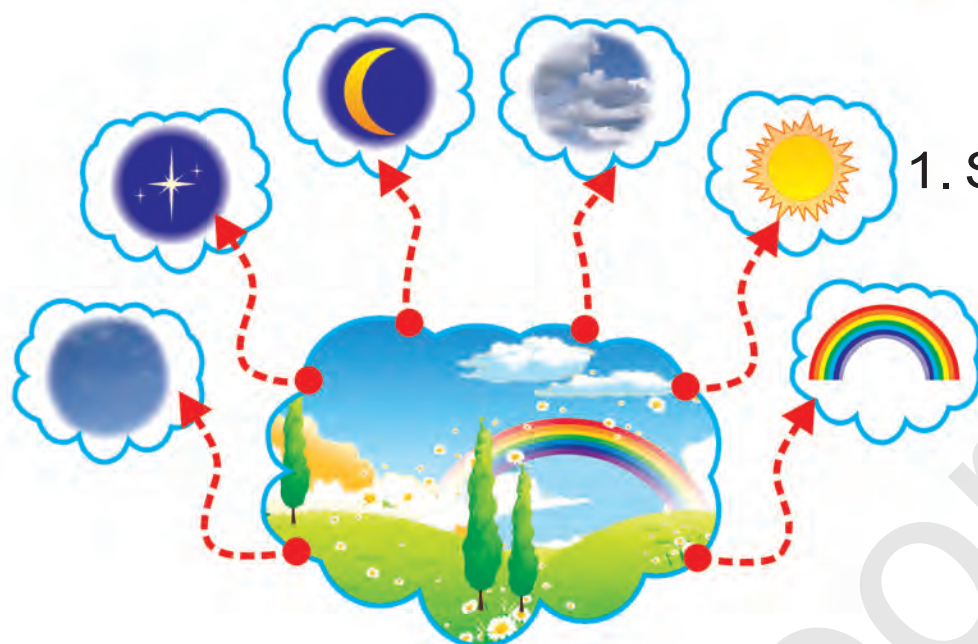

1. Schau mal.



2. Hör und sprich nach.



3. Nenne die Farben.





UMWELT

Bekanntschaft mit Natur



4. Verbinde.

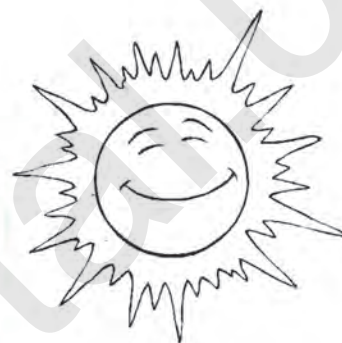
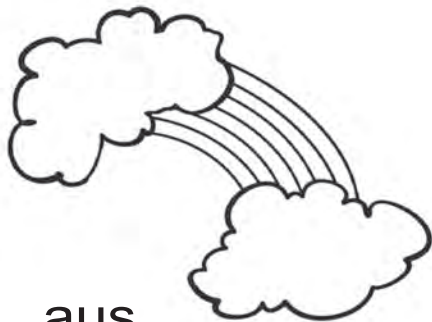

5. Mal aus.

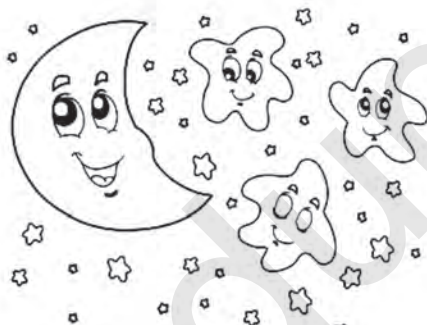

6. Sprich.



UMWELT

Unsere Natur



7. Schau mal.



8. Hör zu.



9. Sprich.

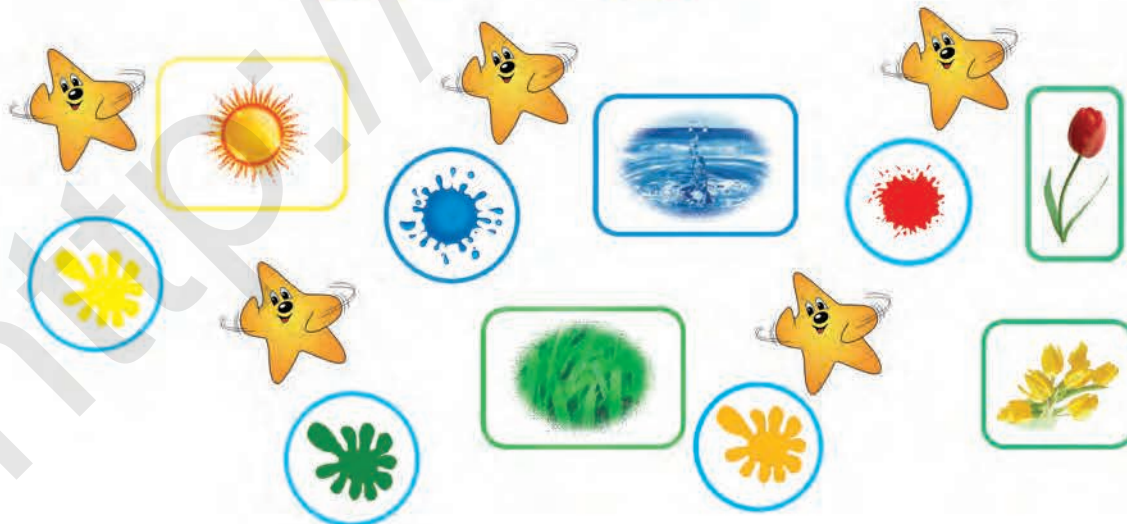
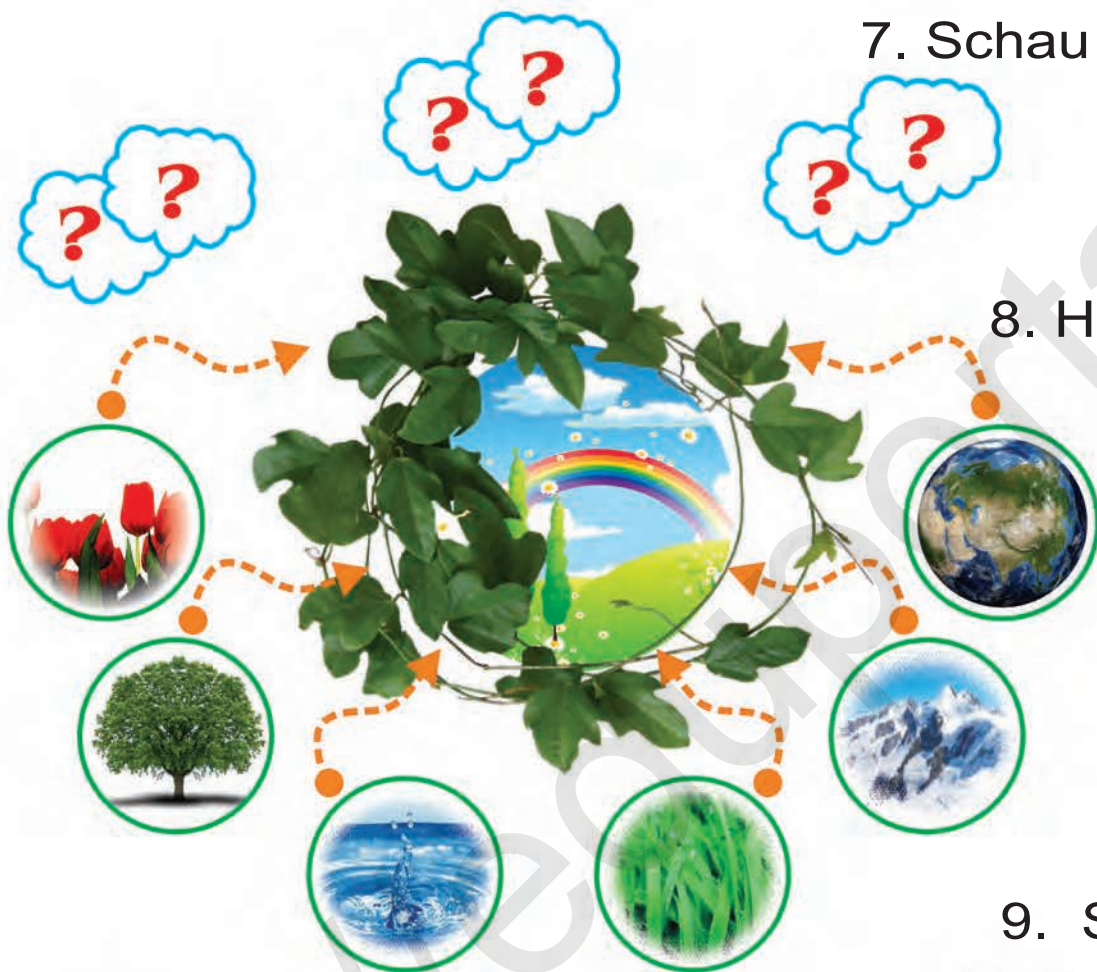



UMWELT

Unsere Natur



10. Verbinde.

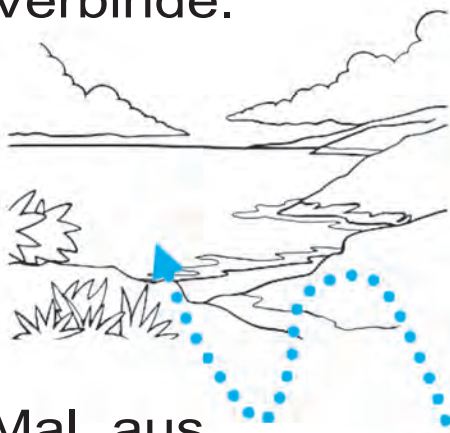

11. Mal aus.



12. Nenne die Farben.



UMWELT

Jahreszeiten



13. Schau mal.



14. Nenne die Jahreszeiten.





UMWELT

Natur und wir



15. Schau mal.



16. Spiel.

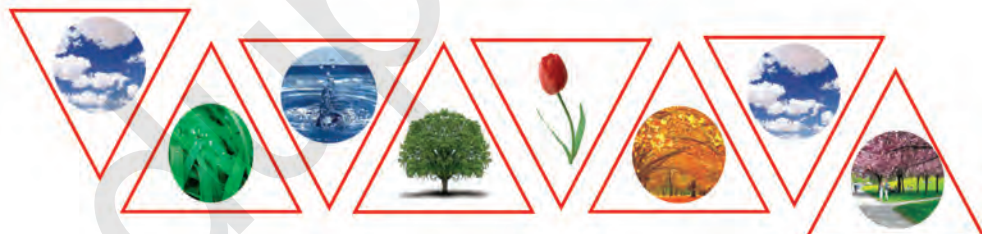

17. Nenne die Gegenstände.

WIEDERHOLUNG

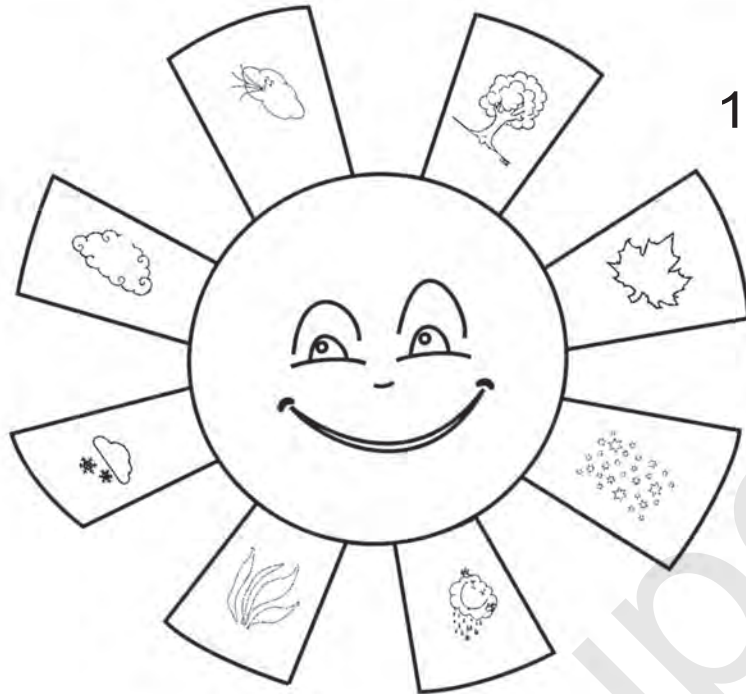

18. Schau mal.

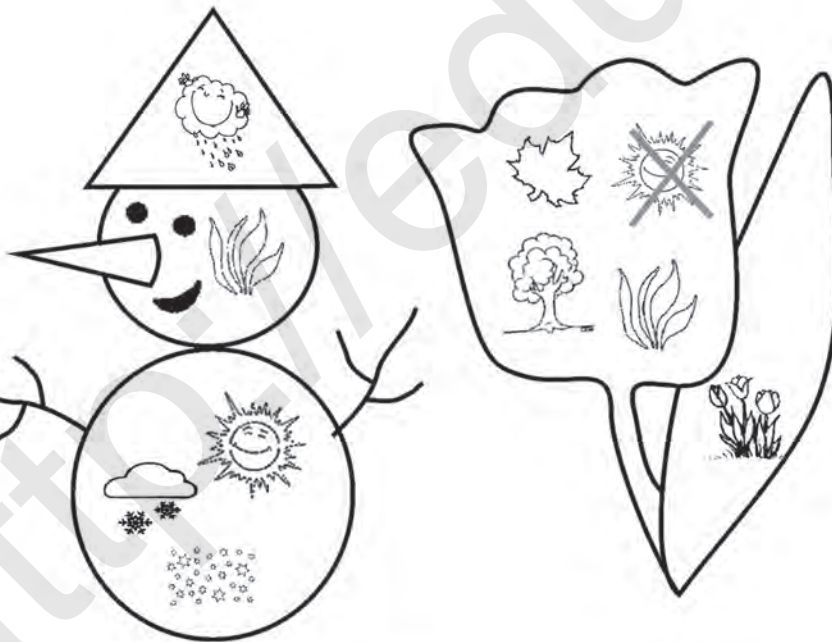

19. Mal aus.



20. Sprich.





KÖRPERTEILE

Was ist das?



1. Schau mal.



2. Sprich nach.



KÖRPERTEILE

Was ist das?



3. Was fehlt? Zeichne.



4. Mal ein Bild von dir und nenne die Körperteile.

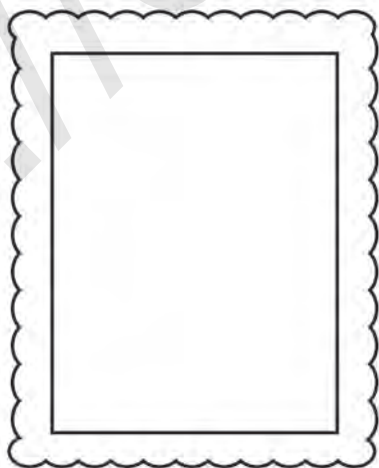



KÖRPERTEILE

Mein Hampelmann



5. Spiel mit.



6. Beschreib.



7. Mal aus.



KÖRPERTEILE

Mein Hampelmann



8. Schneide aus und bastle.

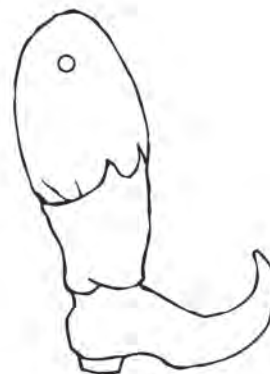
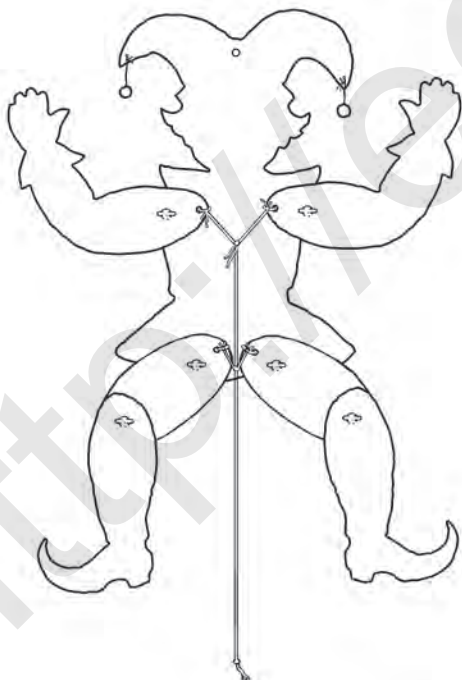
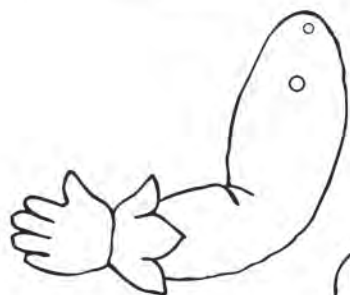
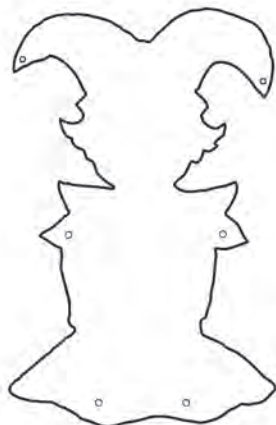



KÖRPERTEILE

Am Morgen



9. Was siehst du?



10. Sprich.



KÖRPERTEILE

Was tut dir weh?



11. Was sagen die Kinder?
Was tut ihnen weh?





MEIN KLASSENZIMMER

In der Klasse



1. Schau mal.



2. Hör die Wörter und nummeriere.

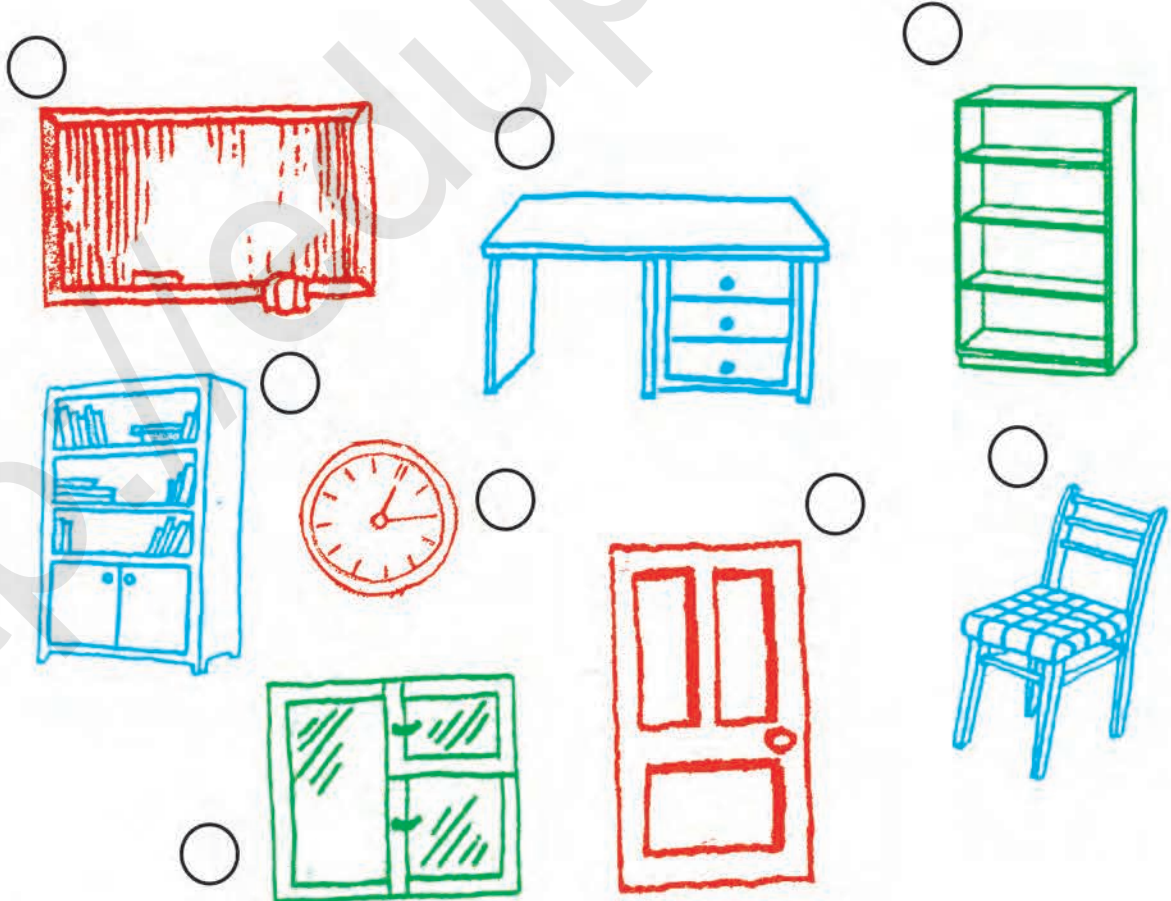

MEIN KLASSENZIMMER

In der Klasse



3. Zeichne und mal aus.

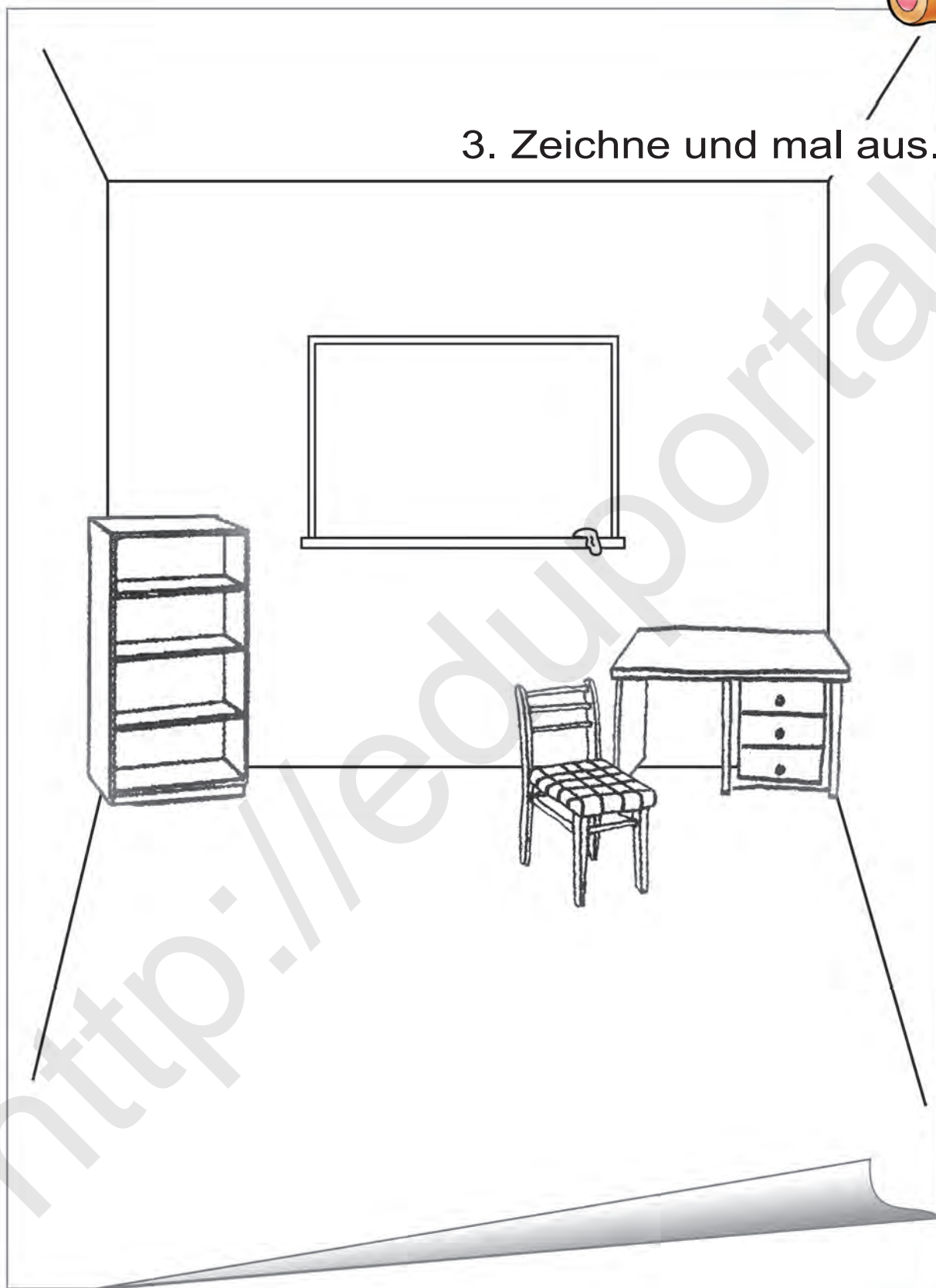



MEIN KLASSENZIMMER

Meine Schulsachen



4. Was ist das?

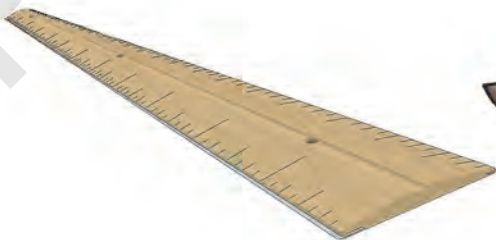
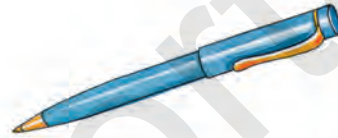

MEIN KLASSENZIMMER

Meine Schulsachen



5. Zeichne und mal aus.





MEIN KLASSENZIMMER

Wer hat was?



6. Vergleiche die Klassenzimmer.



MEIN KLASSENZIMMER

Was habe ich in meiner Schultasche?



7. Was ist falsch?





WIEDERHOLUNG



8. Zeichne und mal aus.

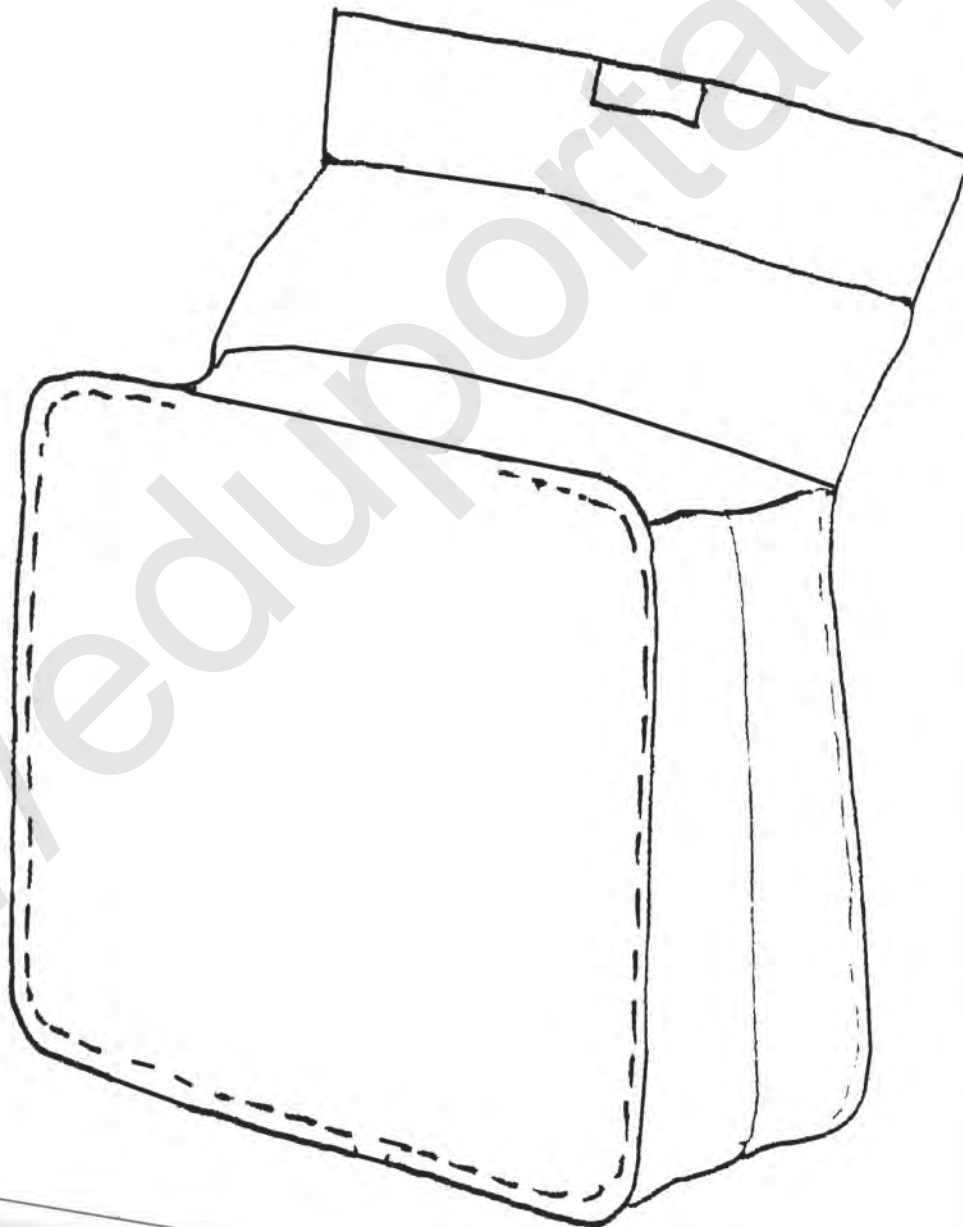

ZAHLEN

Wir zählen (1-10)



1. Schau mal.



2. Hör.



3. Sprich nach.

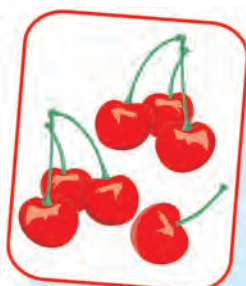



ZAHLEN

Wir zählen (1-10)



4. Zeichne.



5. Mal aus.

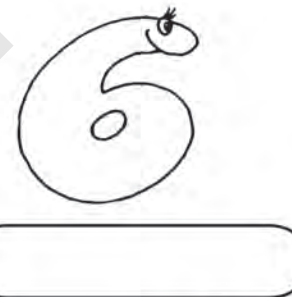

6. Sprich.



ZAHLEN

Wir zählen (11–20)

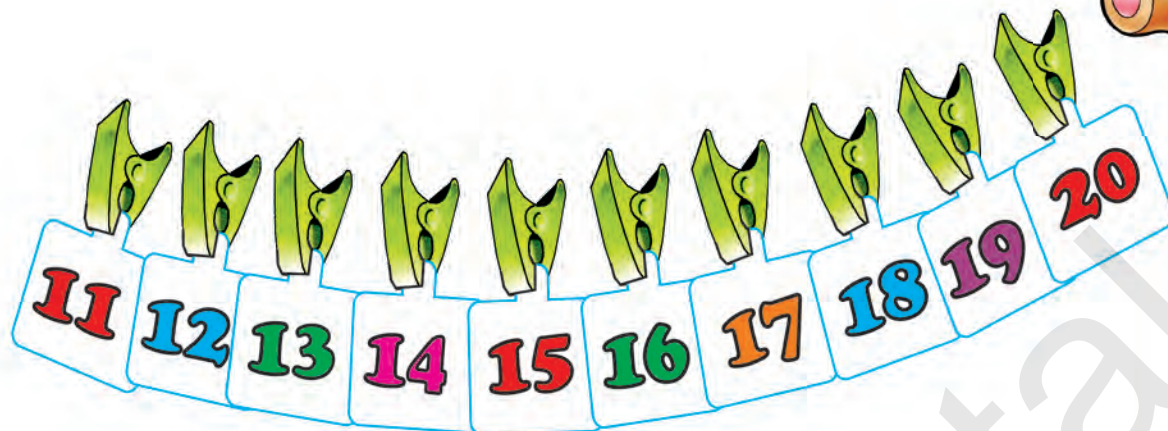

7. Schau mal.



8. Hör.



9. Sprich nach.





ZAHLEN

Wir zählen (11–20)



10. Schau mal.



11. Verbinde die passenden Bilder.



12. Mal aus.



13. Sprich.

ZAHLEN

Welche Zahlen fehlen?



14. Schau mal.

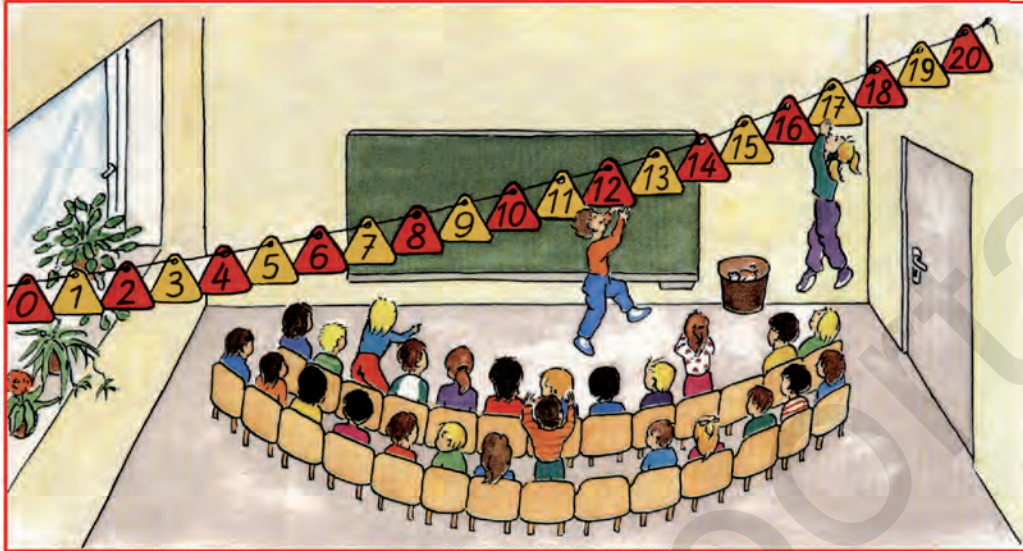

15. Nenne die Zahlen.

0 1	6 7	4 5
8 9	3 4	6 7
3 5	1 3	8 10

9 10	6 8	5 6
12 13	14 16	12 13
17 18	18 20	16 17

10 12	7 10	19 20
18 19	14 15	11 13

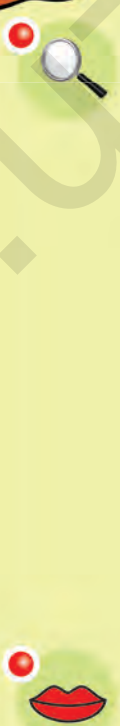



ZAHLEN

Wir zählen spielend



16. Schau mal.



17. Spiel.



18. Nenne die Zahlen.



OBST UND GEMÜSE

Was ist das?



1. Hör.



2. Schau mal.



3. Nenne.

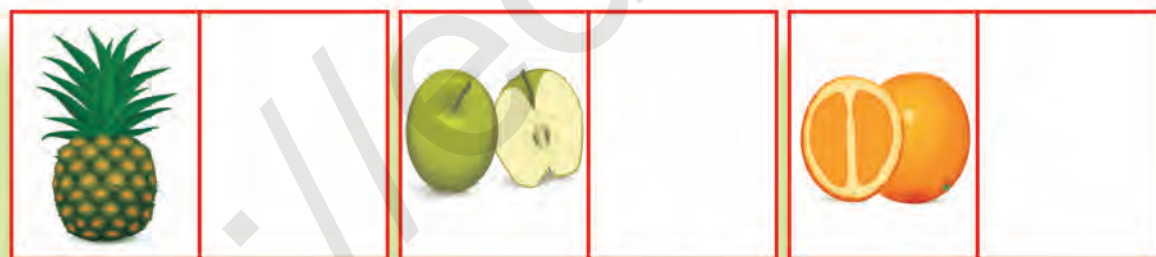

4. Zeichne.





OBST UND GEMÜSE

Was ist das?



5. Puzzle und mal aus.

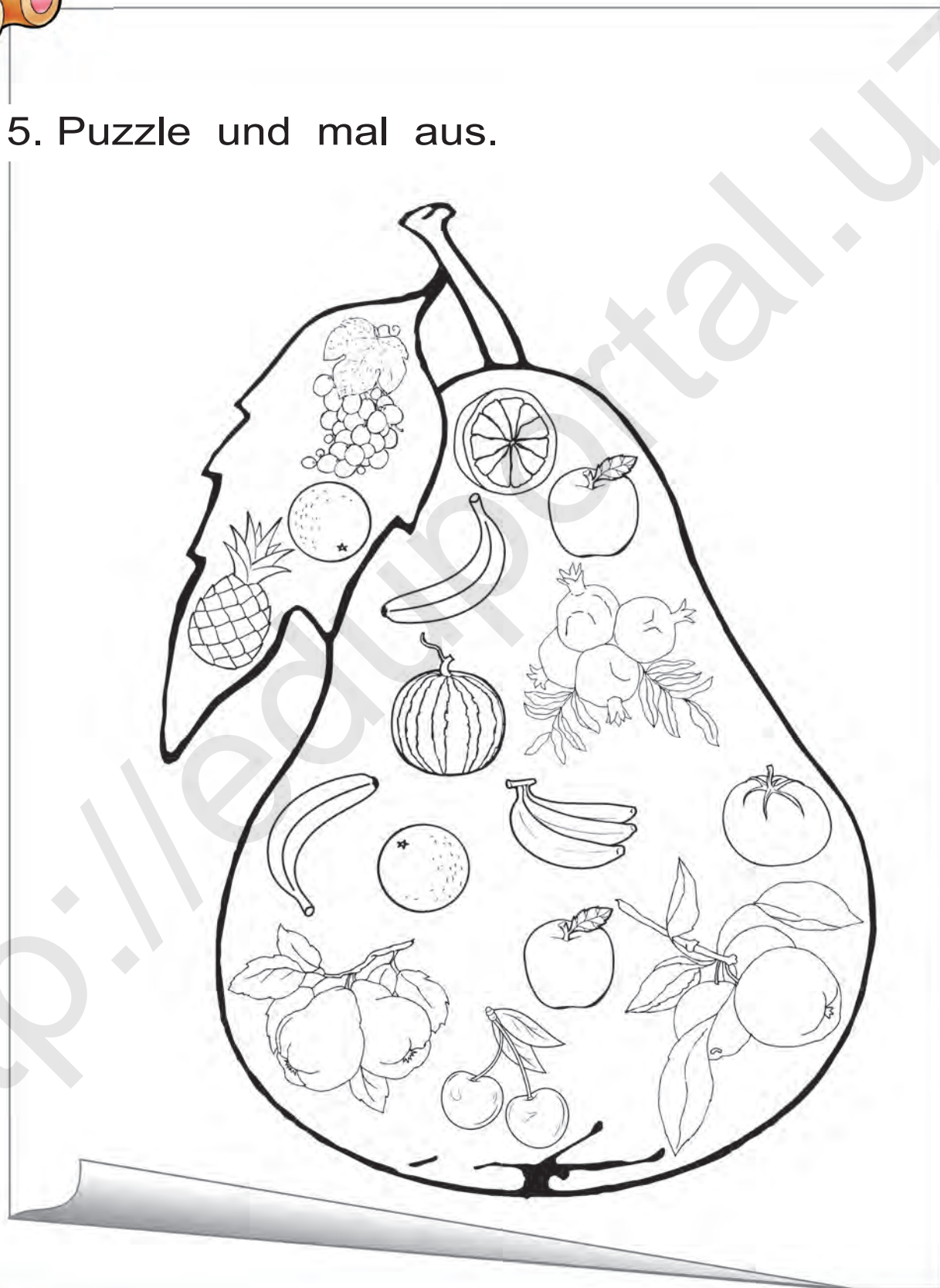

OBST UND GEMÜSE

Nenne Obst und zähle



6. Hör und sprich nach.



7. Spiel Minidialoge.





OBST UND GEMÜSE

Nenne Obst und zähle



8. Mal aus.

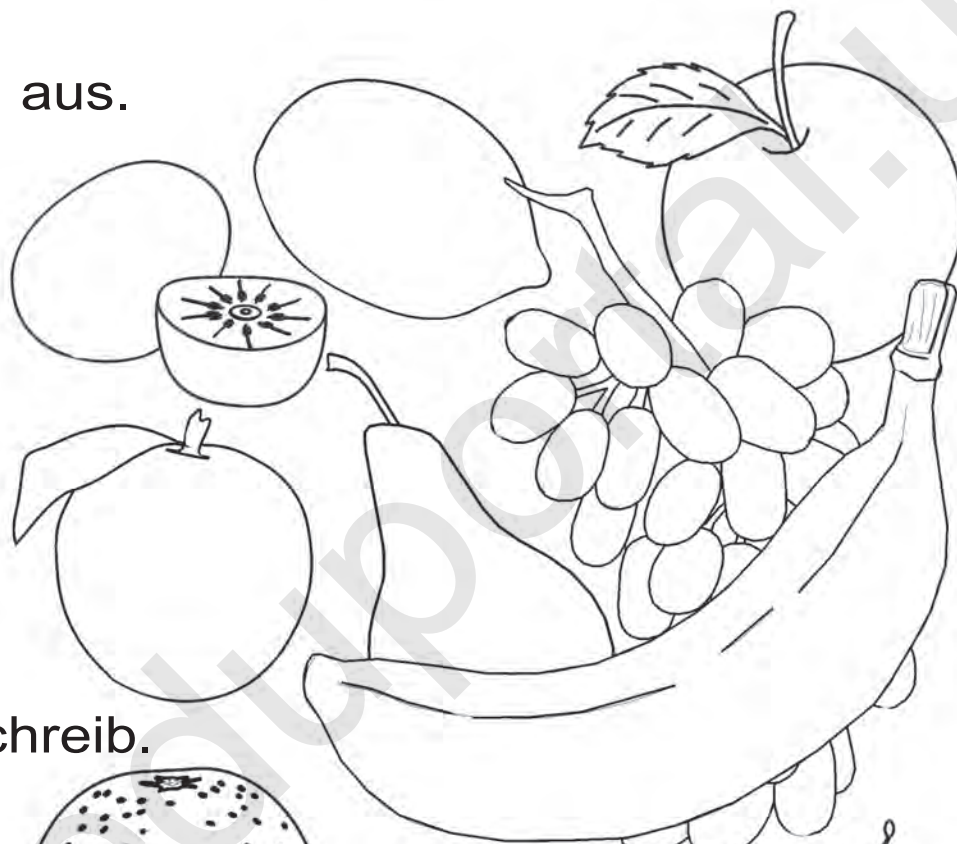

9. Beschreib.



OBST UND GEMÜSE

Sortiere Obst und Gemüse



10. Sprich nach.



11. Hör.





OBST UND GEMÜSE

Obst und Gemüse sind rot,
grün ...



12. Schau mal.



13. Spiel.



14. Nenne Obst und Gemüse.

WIEDERHOLUNG



15. Hör die Musik und nenne Obst und Gemüse.



16. Rollenspiele.





TIERE

Haustiere



1. Hör.



2. Sprich nach.



3. Spiel (Minidialoge).

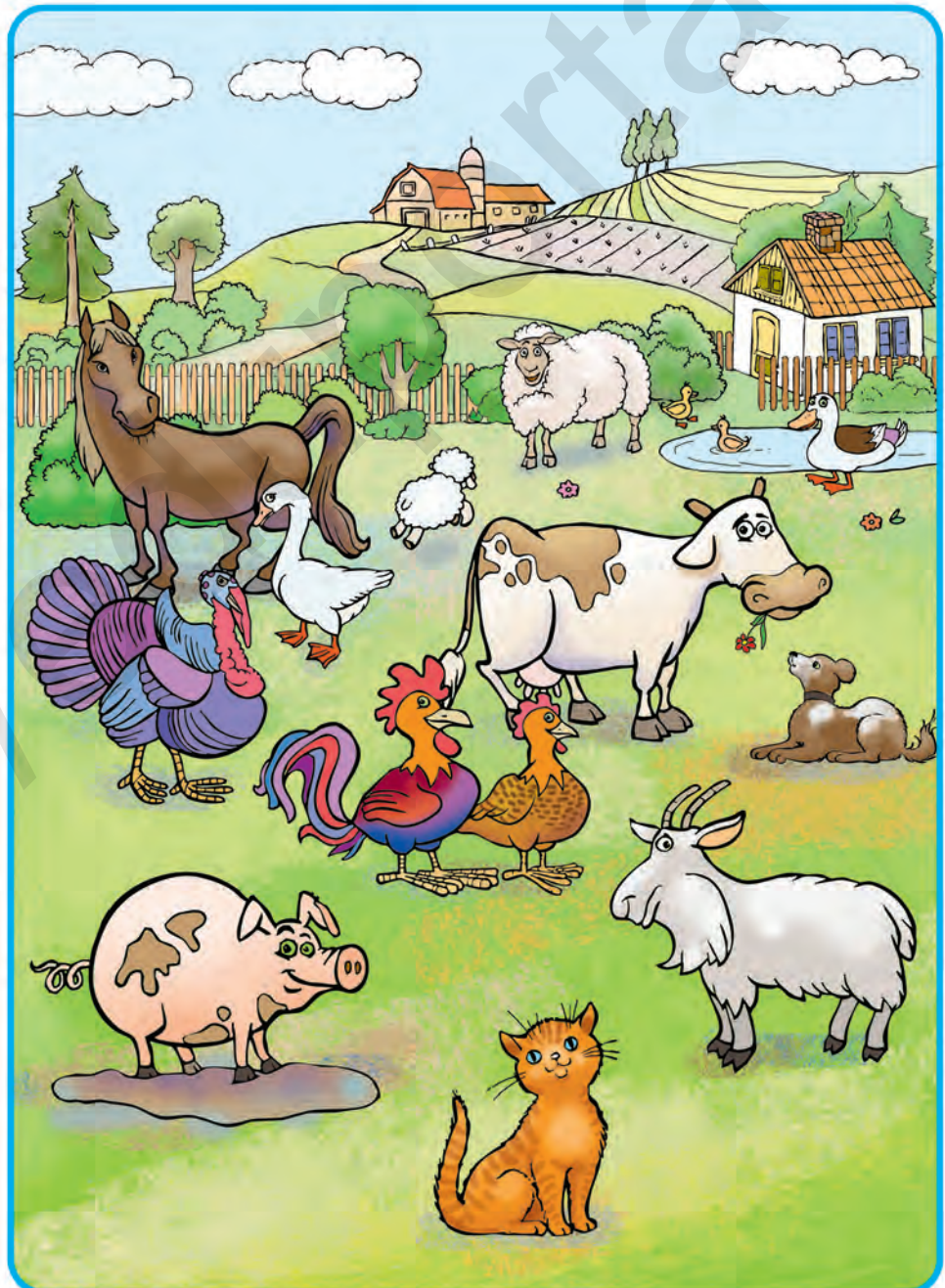

TIERE

Haustiere

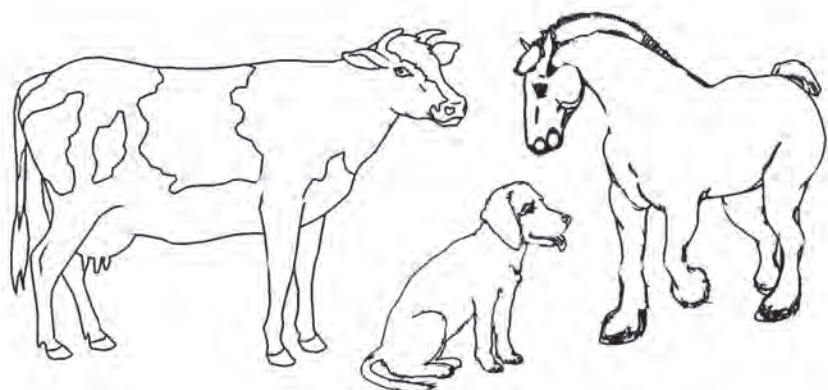

4. Mal aus.

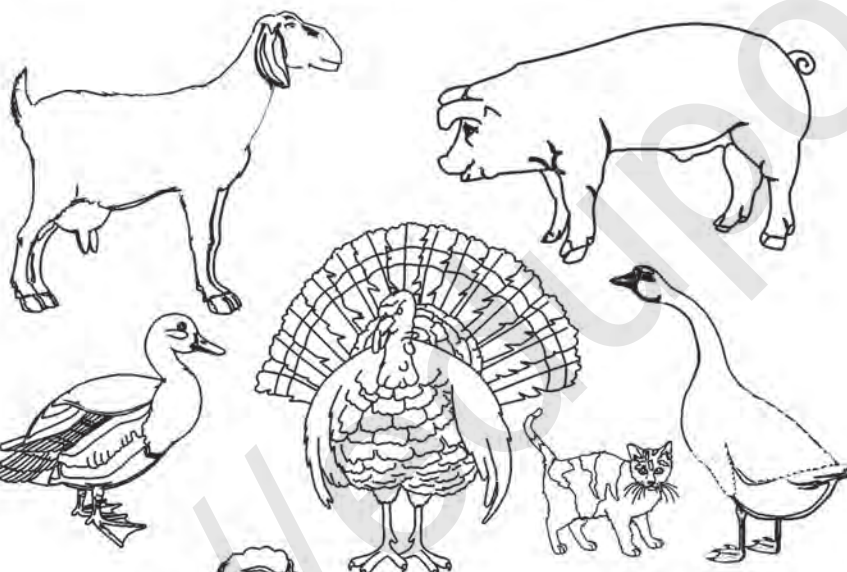

5. Sprich.

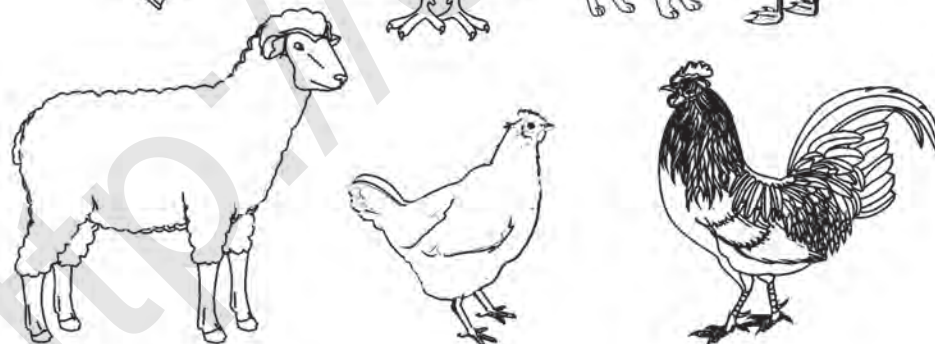



TIERE

Wildtiere



6. Schau mal.



7. Hör.



8. Sprich nach.



9. Spiel mit.

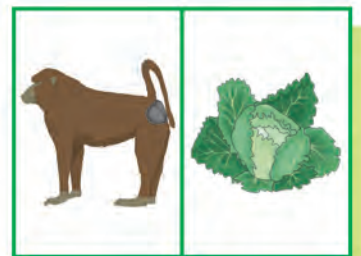
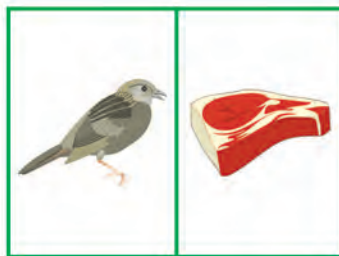
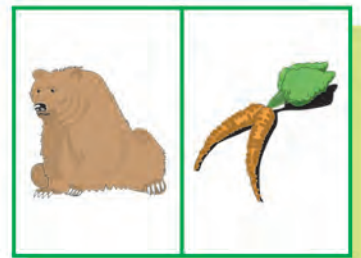
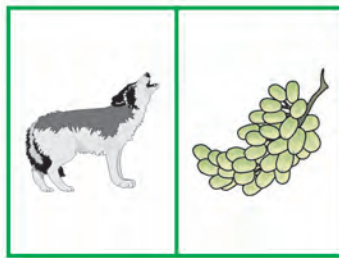
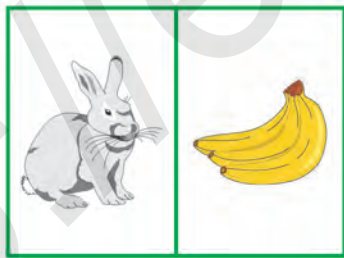

TIERE

Wildtiere

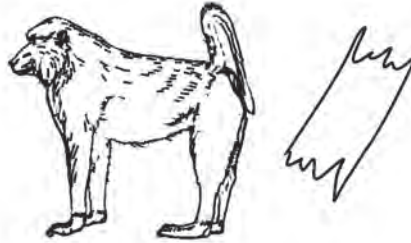
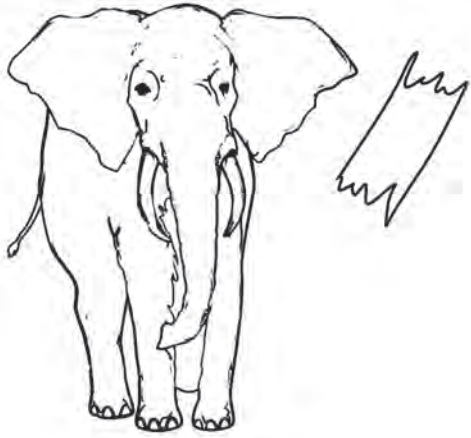

10. Mal aus.

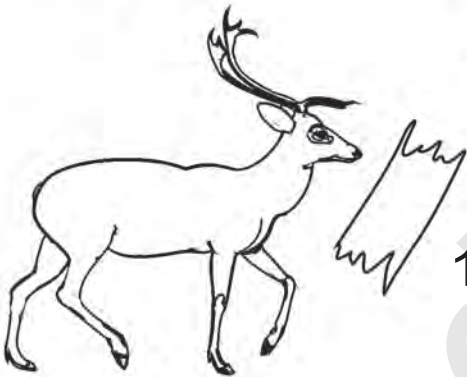
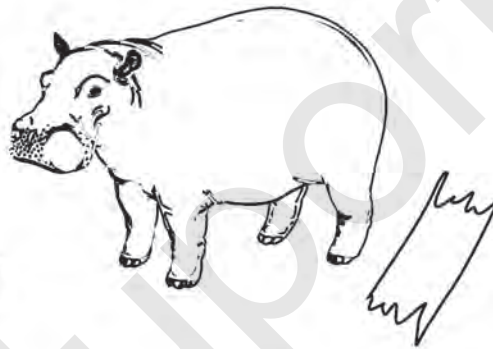

11. Nenne die Wildtiere.

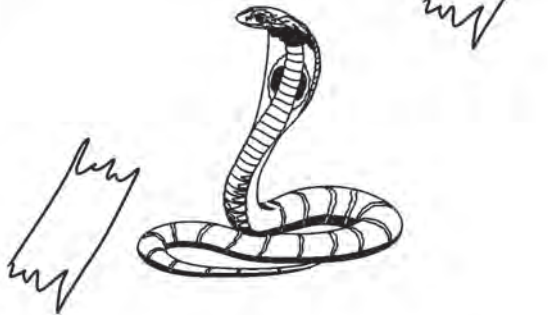
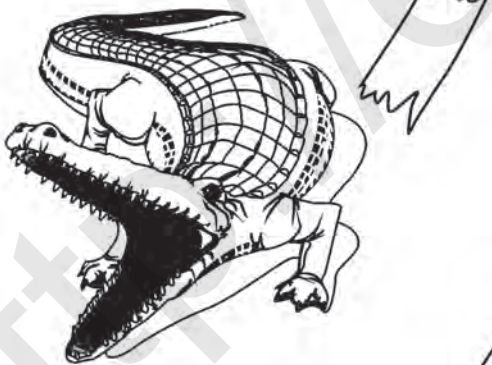



TIERE

Wer frisst was?

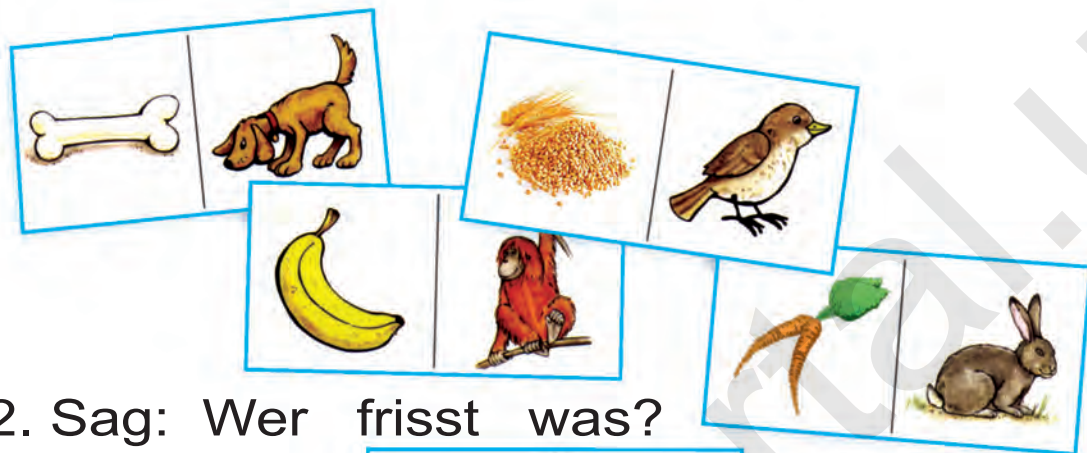

12. Sag: Wer frisst was?



13. Spiel mit.



14. Verbinde.

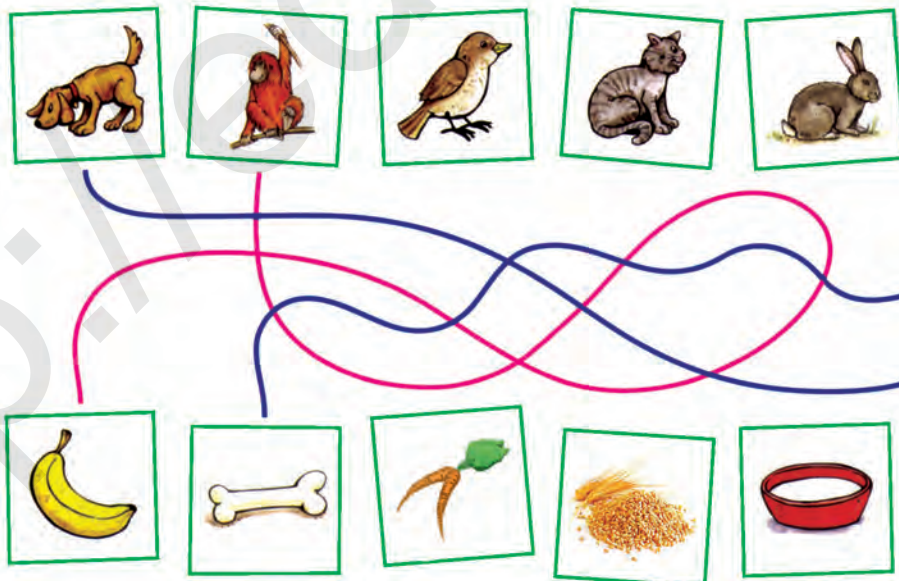

TIERE

Mein Lieblingstier



15. Spiel.



16. Beschreib die Tiere.





WELT DER MÄRCHEN

Kennst du die Märchenhelden?



1. Schau mal.



2. Sag: Wen siehst du?



WELT DER MÄRCHEN

Kennst du die Märchenhelden?

13



3. Mal aus.

4. Nenne die Märchenhelden.





WELT DER MÄRCHEN

Das Märchen heißt ...



5. Schau mal.



6. Hör.



7. Ordne ein.



WELT DER MÄRCHEN

Das Märchen heißt ...



8. Verbinde.



9. Mal aus.





WELT DER MÄRCHEN

Episoden aus Märchen



10. Rollenspiele.



WELT DER MÄRCHEN

Die Haupthelden sind ...



11. Schau mal.



12. Inszeniere.





WIEDERHOLUNG

Die Haupthelden sind ...



13. Zeichne und mal aus.



14. Sag: Was ist das?



WAS KANN ICH TUN? Zu Hause ...



<http://uzedu.net>



WAS KANN ICH TUN? Zu Hause ...



3. Schau mal.

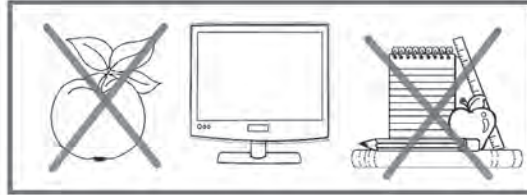

4. Streiche unpassende Bilder aus.

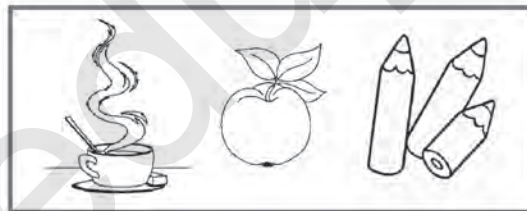

5. Mal aus.



WAS KANN ICH TUN?

In der Klasse ...



6. Schau mal.



7. Was kannst du tun?





WAS KANN ICH TUN?

In der Klasse ...



8. Schau mal.



9. Streiche unpassende Bilder aus.

WAS KANN ICH TUN?

Das kann ich



10. Schau mal.



11. Sag.

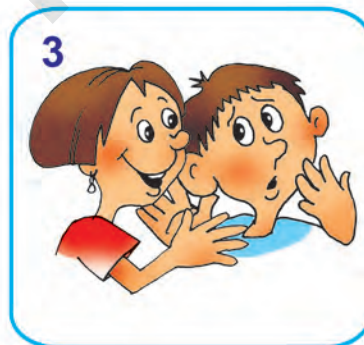



WAS KANN ICH TUN?

Das kann ich



12. Schau mal.

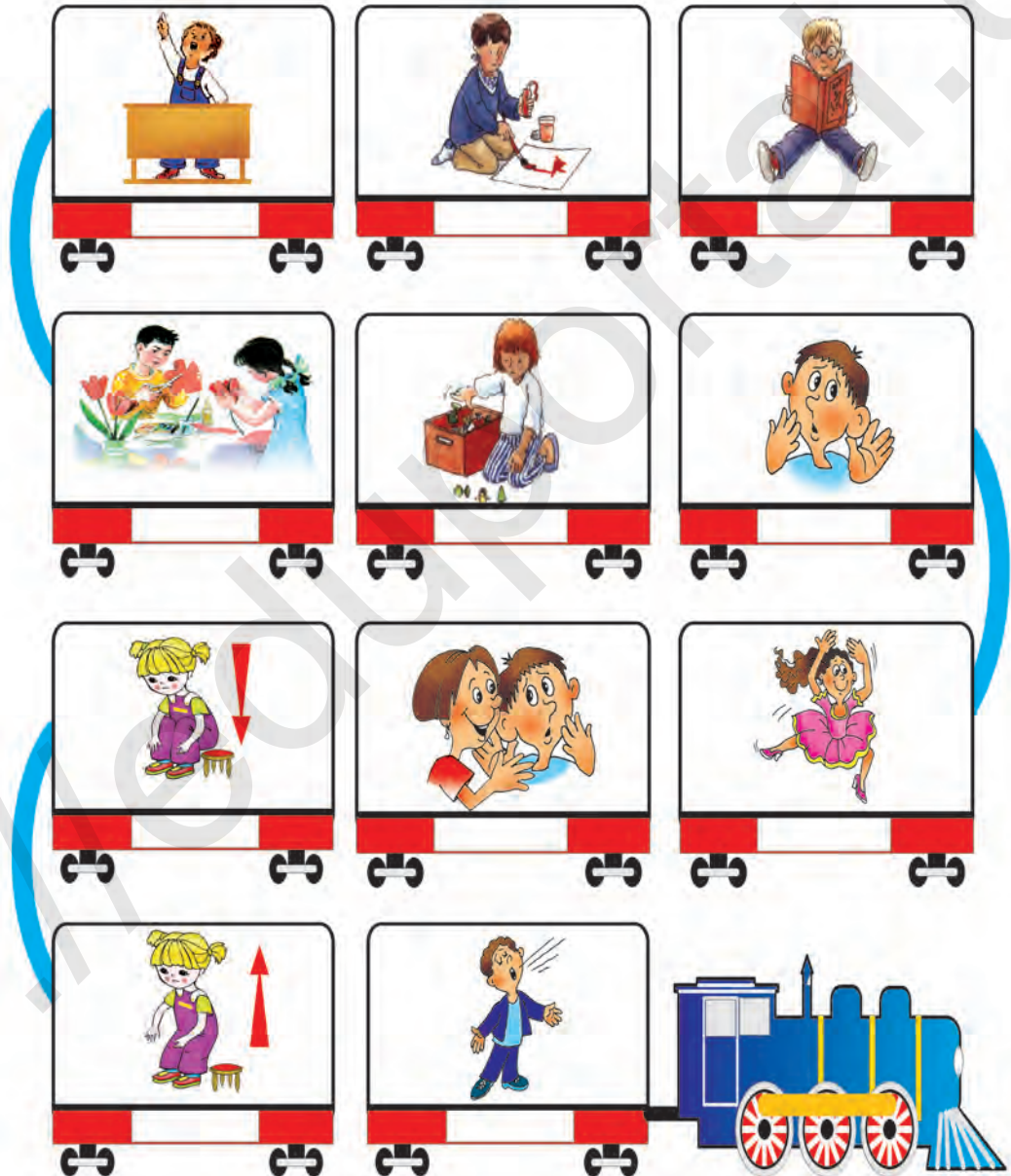

13. Sag: Was kannst du?

WIEDERHOLUNG



14. Sprich: Was kannst du?

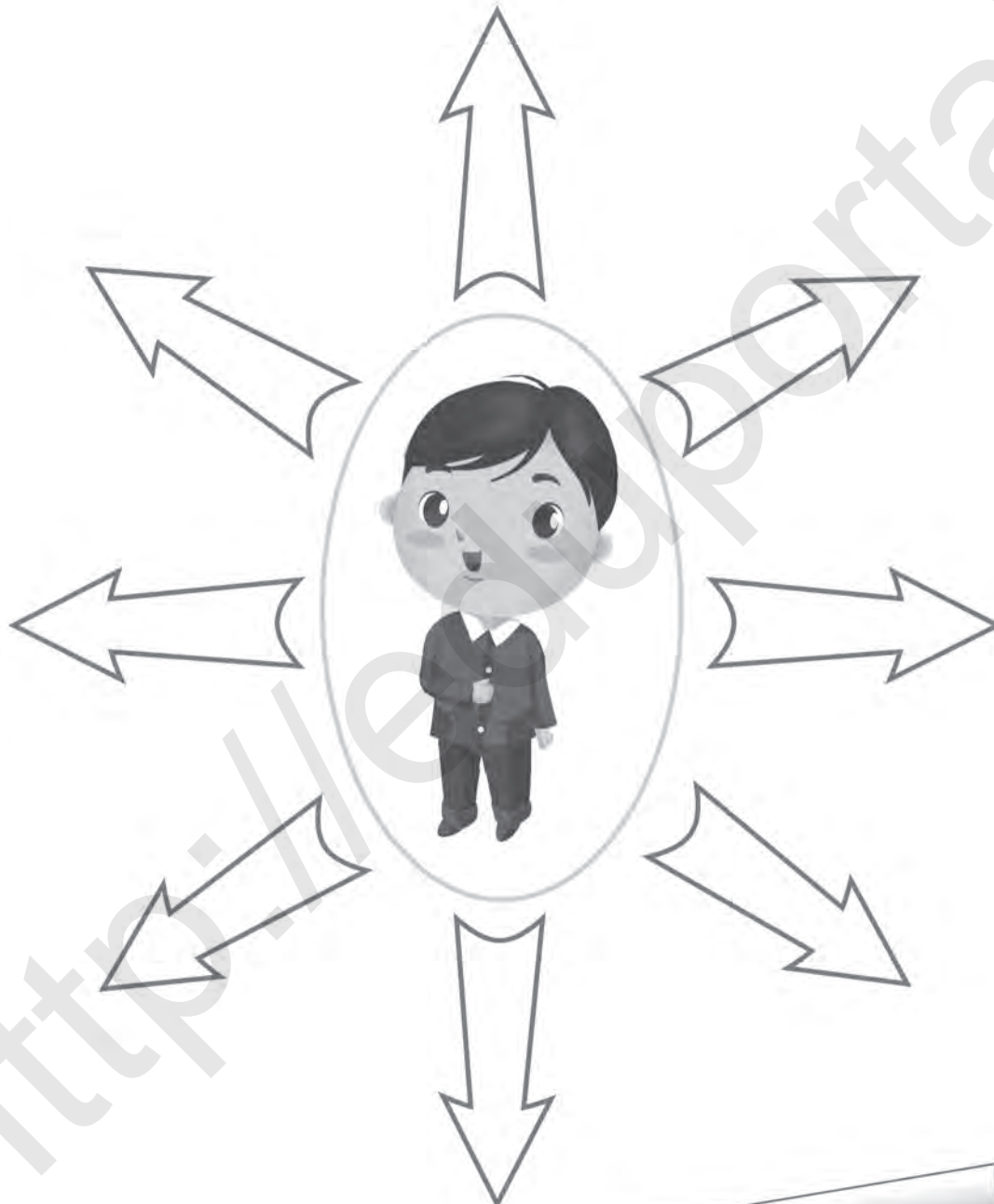



Для родителей

Уважаемые родители!

Ваш ребёнок начал интересное путешествие в мир немецкого языка. После каждого проведённого урока даётся задание на дом для закрепления полученных знаний.

Помогите своим детям в его изучении и повторении.

Если ваш ребёнок не сможет вспомнить слова и предложения пройденной на уроке темы, то не стоит волноваться. Все слова и предложения из урока в урок повторяются, и детям будет легко их запомнить и выучить.

Самое главное, от вас требуется терпение и внимание.

Lektion 1

Das Thema 1 „Bekanntschaft“

1 урок. 1 задание.

На правой стороне страницы закончите раскрашивание картинки Felix Bär (медвежонок по имени Феликс с флажками Узбекистана и Германии в руках). Повторите следующие выражения: “Guten Morgen!”, “Guten Tag!” (Доброе утро!, Добрый день!)

2 урок. 2 задание.

На правой стороне страницы продолжите раскрашивание рисунков: “Guten Morgen!”, “Guten Tag!”, “Guten Abend!” (Доброе утро!, Добрый день! Добрый вечер!), и повторите их, а также выучите, как познакомиться на немецком языке. Hallo! Ich heiÙe ... Mein Name ist Ich bin.... (меня зовут.....).

3 урок. 3 задание.

На правой стороне страницы продолжите раскрашивание рисунка и повторите выражения приветствия и прощания “Wie geht es dir?”, “sich verabschieden, Tschüss!” (Как твои дела? Прощаться. Пока!).

4 урок. 4 задание.

На 10 странице, повторить выражения, название прибора измерения “Wie geht`s?”, “Prima! Danke, gut! Es geht. Schlecht”. – (“Как ваше здоровье?”) (“Отлично! Спасибо, хорошо! Пойдет. Плохо!”)

Для родителей



Lektion 2

Das Thema “Alles über mich”

1 урок. 1 задание.

На 12 странице продолжить раскрашивание рисунков.

2 урок. 2 задание.

На 14 странице продолжить раскрашивание рисунков и повторите местоимения Ich, du, er, sie, es, wir, ihr, sie, Sie (я, ты, он, она, мы, вы, они, Вы).

3 урок. 3 задание.

На 15 странице повторить ответы на вопросы, касающиеся возраста: Ich bin 7 (sieben) Jahre alt (Мне 7 (семь) лет.) Wie alt bist du? (Сколько тебе лет?)

4 урок. 4 задание.

На 16 странице по рисункам помогите составить диалог о месте проживания.

Lektion 3

Das Thema “Die Familie ”

1 урок. 1 задание.

На 18 странице раскрасить рисунки с изображением членов семьи и назвать их. Das ist der Opa, die Oma, die Mutter, der Vater, die Schwester, der Bruder. (Это дедушка, бабушка, мама, отец, сестра, брат).

2 урок. 2 задание.

На 20 странице раскрасить рисунки с изображением членов семьи, назвать их по именам: Das ist der Opa. Er heißt Das ist die Oma. Sie heißt..... (Это дедушка. Его зовут... . Это бабушка. Её зовут... .)

3 урок. 3 задание.

На 21 странице помогите рассказать о членах семьи, указанных на рисунке.

4 урок. 4 задание.

На 22 странице по рисунку помогите назвать слова на тему “Моя семья”.



Для родителей

Lektion 4

Das Thema „Mein Freund“

1 урок. 1 задание.

На 24 странице раскрасить рисунки друзей и назвать их возраст и имена: Das ist mein Freund. Das ist meine Freundin. Er heißt Sie heißt Er ist ... Jahre alt. Sie ist ... Jahre alt.

(Он мой друг. Она моя подруга. Его зовут Её зовут Ему ... лет. Ей ... лет).

2 урок. 2 задание.

На 26 странице раскрасить рисунки и указать национальность своих друзей: Ich bin Usbeke. Ich bin Deutsche. Ich spreche usbekisch. Ich spreche deutsch. (Я узбек. Я немец. Я говорю на узбекском языке. Я говорю на немецком языке.)

3 урок. 3 задание.

На 27 странице помогите повторить слова и выражения, касающиеся места проживания.

4 урок. 4 задание.

На 28 странице помогите нарисовать на отведённом месте портрет друга.

Lektion 5

Das Thema „Farben“

1 урок. 1 задание.

На 31 странице помогите раскрасить рисунки и соединить линией подходящие по цвету рисунки.

2 урок. 2 задание.

На 33 странице продолжить раскрашивание рисунка, помочь соединить линией и определить, какой предмет кому принадлежит.

3 урок. 3 задание.

На 34 странице помочь детям повторить названия цветов красок, изображенных на рисунке.

4 урок. 4 задание.

На 35 странице помочь раскрасить рисунки и назвать соответствие цветов.

Для родителей



Lektion 6

Das Thema „Spielzeuge“

1 урок. 1 задание.

На 37 странице в рисунках недорисованы некоторые части. Помогите ребёнку дорисовать их и раскрасить.

2 урок. 2 задание.

На 39 странице закончить раскрашивание рисунка и повторить название данных игрушек.

3 урок. 3 задание.

Назвать любимые игрушки ребенка и помочь соединить их в словосочетание *der Ball, die Puppe, das Legospiel, das Auto, der Teddybär* (мяч, кукла, лего, машина, медведь).

4-урок. 4-задание.

Помочь ребёнку нарисовать любимые игрушки и повторить их названия на немецком языке.

Повторение.

На 39 странице помогите нарисовать любимые игрушки и раскрасить их.

На 42 странице помогите подсчитать количество размещенных в квадратах игрушек.

Lektion 7

Das Thema „Umwelt“

1 урок. 1 задание.

На 43 странице раскрасить рисунки, назвать природные явления: *der Himmel, der Stern, der Mond, die Wolke, die Sonne und der Regenbogen* (небо, звезды, луна, облака, солнце, радуга).

2 урок. 2 задание.

На 43 странице помочь раскрасить картинки и повторить изображенное: *die Blume, der Baum, der Berg, das Blatt, das Wasser*. (Цветы, деревья, горы, листья, вода).



Для родителей

3 урок. 3 задание.

На 46 странице помочь назвать времена года на рисунках: der Winter, der Sommer, der Herbst, der Frühling (зима, лето, весна, осень) и повторить их.

4 урок. 4 задание.

Помочь раскрасить картинки, повторить их названия.

Повторение.

На 49 странице помочь раскрасить рисунки и повторить их.

Lektion 8

Das Thema „Körperteile“

1 урок. 1 задание.

На 51 странице дорисовать части тела, изображённые на картинке, и назовите их: der Kopf, der Hals, die Hand, die Augen, das Bein, das Ohr, der Mund, der Finger (голова, шея, рука, нога, глаза, уши, рот, пальцы).

2 урок. 2 задание.

На 53 странице помочь вырезать части тела, затем смастерить из них человечка.

3 урок. 3 задание.

На 54 странице помочь назвать предметы гигиены и повторить их на немецком языке: der Kamm, die Zahnbürste, die Zahnpasta, die Seife, das Handtuch (расческа, зубная щетка, зубная паста, мыло, полотенце).

4 урок. 4 задание.

На 55 странице помочь составить беседу с врачом о болезнях головы, зубов и ног.

Lektion 9

Das Thema „Mein Klassenzimmer“

1 урок. 1 задание.

На 57 странице помочь нарисовать и раскрасить школьные принадлежности.

2 урок. 2 задание.

На 59 странице дорисовать недостающие части учебных принадлежностей, раскрасить и назвать их на немецком языке: das Buch,

Для родителей



der Bleistift, die Mappe, das Heft, das Lineal, der Kuli (книга, карандаш, портфель, тетрадь, линейка, ручка).

3 урок. 3 задание.

На 60 странице помочь сравнить две картинки с классными предметами и назвать их.

4 урок. 4 задание.

На 61 странице помочь назвать предметы, которые не относятся к учебным принадлежностям и не должны находиться в портфеле.

Повторение.

На 62 странице помочь раскрасить рисунок портфеля.

Lektion 10

Das Thema "Zahlen"

1 урок. 1 задание.

На 64 странице раскрасить рисунки с цифрами, и назвать на немецком языке числительные от 1 до 10. (eins, zwei, drei, vier, fünf, sechs, sieben, acht, neun, zehn).

2 урок. 2 задание.

На 66 странице помочь раскрасить рисунки и соединить с соответствующими цифрами.

3 урок. 3 задание.

На 67 странице рассмотреть и назвать цифры.

4 урок. 4 задание.

На 68 странице помочь назвать количество фруктов, указанных на рисунке.

Lektion 11

Das Thema "Obst und Gemüse"

1 урок. 1 задание.

На 70 странице помочь раскрасить рисунок с фруктами и назвать их количество на немецком языке.

2 урок. 2 задание.

На 72 странице помочь раскрасить рисунки с фруктами в соответствующие цвета и рассказать о них.



Для родителей

3 урок. 3 задание.

На 73 странице помочь назвать нарисованные овощи.

4 урок. 4 задание.

На 74 странице помочь назвать овощи и фрукты.

Повторение.

На 75 странице помочь назвать нарисованные овощи и фрукты.

Lektion 12

Das Thema “Tiere“ (Haustiere)

1 урок. 1 задание.

На 77 странице помочь раскрасить домашних животных, вспомнить их названия и рассказать о них на немецком языке.

2 урок. 2 задание.

На 79 странице помочь раскрасить диких животных и назвать их. Например: Das ist der Wolf (Это волк).

3 урок. 3 задание.

На 80 странице помочь соединить отдельные чёточки и назвать, какой получился зверёк.

4 урок. 4 задание.

На 81 странице помочь назвать животных на картинке.

Lektion 13

Das Thema “Welt der Märchen“

1 урок. 1 задание.

На 83 странице помочь раскрасить героев сказки, назвать их имена на немецком языке.

2 урок. 2 задание.

На 85 странице помочь раскрасить рисунки персонажей сказки, соединить линией.

3 урок. 3 задание.

На 86 странице помочь создать игровые роли на основе эпизодов из сказки.

Для родителей



4 урок. 4 задание.

На 87 странице помочь назвать героев сказки.

Повторение.

На 88 странице помочь раскрасить рисунок и рассказать о нём.

Lektion 14

Das Thema “Was kann ich tun?”

1 урок. 1 задание.

На 89 странице по картинке расскажите о том, “Что я могу делать?”. Из данных словосочетаний составить предложения на немецком языке: Ich kann zeichnen, ausmalen, spielen. (Я могу рисовать, раскрашивать, играть).

2 урок. 2 задание.

На 90 странице убрать “лишние” рисунки и раскрасить их.

3 урок. 3 задание .

На 92 странице убрать “лишние” рисунки и раскрасить их.

4 урок. 4 задание.

На 94 странице помогите правильно ответить на вопрос “Что я могу делать?” Я могу считать, познакомиться, рассказать о друге, о животных и о картинках.

Повторение.

На 95 странице помогите правильно ответить на вопрос “Что ты можешь делать?”

Манзура Дадаходжаева, Зухра Нарбекова, Арзигуль Мирсалимова,
Рената Файзулина, Дилбар Таджибаева, Танзиля Гафурова,
Наталья Суханова, Алла Беканачева, Лутфулла Холияров

DEUTSCH MIT SPAZ

1-sinf uchun nemis tili darsligi

(*Rus tilida*)

Перевод *Тахиры Алимовой*
Художник-дизайнер *Шухрат Мирфаязов*
Художники: *Коробова Татьяна, Чапленко Андрей*
Редакторы: *Шахноза Сатторова, Тахира Алимова*
Технический редактор *Хосият Хасанова*
Компьютерная вёрстка *Хилола Шарипова*

Лицензия издательства AI № 290. 04.11. 2016
Подписано в печать 12 марта 2019 года. Формат 60x90 1/8.
Печать офсетная. Кегль 18. Гарнитура ARIAL. Усл.печ.л. 13,0.
Уч-изд.л. 16,0. Тираж 1346. Заказ №

Отпечатано в Издательско-полиграфическом
творческом доме имени Гафура Гуляма
Агентство информации и массовых коммуникаций
при Администрации Президента Республики Узбекистан.
100128. г. Ташкент ул. Лабзак, 86.

Телефон: (371) 241-25-24, 241-48-62, 241-83-29
Факс: (371) 241-82-69

www.gglit.uz iinfo@gglit.uz

Deutsch mit Spaß: учебник немецкого языка для 1-го класса. –
Ташкент: Издательско-полиграфический творческий дом имени
Гафура Гуляма, 2019. – 104 с.

ISBN 978-9943-5549-7-9

УДК 811.112.2 (075)
КБК 81.2 Нем