

**B. Q. HAYDAROV**

# **МАТЕМАТИКА 5**

Umumiy o'rta ta'lim maktablarining  
5- sinfi uchun darslik

Qayta ishlangan va to'ldirilgan ikkinchi nashri

*O'zbekiston Respublikasi  
Xalq ta'limi vazirligi tasdiqlagan*

TOSHKENT  
«YANGIYO'L POLIGRAF SERVIS»  
2015

UO'K: 372.851(075)

KBK 22.1(50')

H 19

Haydarov B. Q.

**Matematika 5 sinf** : umumiy o'rta ta'lim maktablarining 5- sinfi uchun darslik / B. Q. Haydarov.  
- Qayta ishlangan va to'ldirilgan ikkinchi nashri. - Toshkent : Yangiyo'l Poligraf Servis, 2015.  
- 240 b.

ISBN 978-9943-979-12-3

UO'K: 372.851(075)

KBK 22.1(50')ya72













- Taqrizchilar – **Sh. A. Alimov** – fizika-matematika fanlari doktori, O'zMU professori;  
**M. M. Tleumuratov** – Xalq ta'limi a'lochisi, Xo'jayli tumani 70- maktab oliy toifali matematika o'qituvchisi;  
**M. M. Shoniyozova** – Toshkent shahar 300- maktab o'qituvchisi;  
**I. V. Chernyakova** – Toshkent shahar 2- maktab o'qituvchisi.

### Aziz o'quvchi!

Siz bu o'quv yilida ham matematika bilan tanishishda davom etasiz. Matematika ming yillar muqaddam inson ehtiyojlarining mahsuli sifatida vujudga kelgan. Uning rivojiga buyuk ajdodlarimiz – sharqning mashhur allomalari, buyuk matematik olimlari ulkan hissa qo'shishgan. Hozirda hech bir kishi matematikani bilmasdan turib, o'z turmushini bekamu-ko'st tasavvur qila olmaydi. Matematika sizga shunchaki hisob-kitob ishlarini o'rgatib qolmasdan, eng asosiysi – sizni mantiqiy fikrlashga, mushohada yuritishga, hayotiy muammolarning eng maqbul yechimini topishga yordam beradi, aqlingizni peshlaydi.

Qo'lingizdagi mazkur darslik ezgu maqsadlaringizni amalga oshishida sizga hamrohlik qiladi, beminnat yordamchi bo'ladi. Uning sahifalaridan nafaqat matematikaga oid ma'lumotlar bilan, balki texnika, fan tarixi, atrof-olam va kundalik turmushga oid qiziqarli va foydali ma'lumotlar bilan ham tanishasiz. Bu ma'lumotlar turli-tuman masala va misollar ko'rinishida e'tiboringizga havola qilinmoqda.

Darslik sahifalarida nazariy ma'lumotlar, qoida, masala va topshiriqlar quyidagi belgilar ostida berilgan:

- |  |  |
|--|--|
|  – Eslab qolish lozim bo'lgan nazariy ma'lumot va tushunchalar;     |  – Faollashtiruvchi mashqlar;                                       |
|  – O'zlashtirilgan bilimlarni nazorat qilishga doir topshiriqlar;   |  – Sinfda bajariladigan mashqlar;                                   |
|  – Og'zaki bajariladigan mashqlar;                                  |  – Uyda bajariladigan mashqlar;                                     |
|  – O'tilganlarni takrorlash uchun berilgan mashqlar;                |  – Yaxshi o'zlashtiruvchi o'quvchilar uchun mo'ljallangan mashqlar; |
|  – O'tilganlarni og'zaki takrorlash uchun berilgan mashqlar;        |  – Matematika tarixiga oid lavhalar va topshiriqlar;                |
|  – Bitta darsga ajratilgan mashqlarni bir-biridan ajratuvchi belgi; |  – Qiziqarli matematikaga oid masalalar.                            |

Respublika maqsadli kitob jamg'armasi mablag'lari hisobidan chop etildi.

ISBN 978-9943-979-12-3

© B. Q. Haydarov, 2011, 2015.

© «Yangiyo'l poligraf servis», 2011, 2015

## MUNDARIJA

### I bob. Natural sonlar va shkalalar

1. Natural son tushunchasi. Natural sonlarning yozilishi va o'qilishi .....	5
2. Kema. Kesmaning uzunligi. Uchburchak .....	11
3. Tekislik, to'g'ri chiziq va nur .....	17
4. Shkalalar va koordinatalar. Sonlar nuri.....	20
5. Natural sonlarni taqqoslash. Katta va kichik.....	28
6. I bobni takrorlashga doir masalalar .....	32

### II bob. Natural sonlarni qo'shish va ayirish

7. Natural sonlarni qo'shish va uning xossalari .....	36
8. Natural sonlarni ayirish va uning xossalari .....	41
9. Sonli va harfli ifodalar .....	46
10. Qo'shish va ayirish xossalari harfiy ifodasi .....	48
11. Tenglamalar.....	51
12. II bobni takrorlashga doir masalalar. ....	57

### III bob. Natural sonlarni ko'paytirish va bo'lish

13. Natural sonlarni ko'paytirish va uning xossalari.....	62
14. Natural sonlarni bo'lish .....	67
15. Qoldikli bo'lish .....	72
16. Ifodalarni soddalashtirish.....	75
17. Natural sonlar ustida to'rt amalga doir masalalar yechish. Amallarni bajarish tartibi .....	81
18. Sonning darajasi. Sonning kvadrati va kubi .....	85
19. III bobni takrorlashga doir masalalar .....	88

### IV bob. Yuz va hajmlar

20. Formulalar .....	92
21. Yuz. To'g'ri to'rtburchak va kvadrat yuzi formulalari.....	95
22. Yuz o'lchov birliklari.....	100
23. To'g'ri burchakli parallelepiped va kub .....	103
24. Hajm. Hajm o'lchov birliklari. To'g'ri burchakli parallelepiped va kub hajmi formulalari .....	108
25. IV bobni takrorlashga doir masalalar .....	114

### V bob. Oddiy kasrlar

26. Aylana va doira.....	117
27. Ulushlar. Oddiy kasrlar haqida tushuncha.....	119
28. Kasrlarni taqqoslash .....	124
29. To'g'ri va noto'g'ri kasrlar .....	128
30. Bir xil maxrajli kasrlarni qo'shish va ayirish .....	131
31. Bo'lish va kasrlar .....	136
32. Aralash sonlar.....	139
33. Aralash sonlarni qo'shish va ayirish .....	144
34. V bobni takrorlashga doir masalalar .....	151

## VI bob. O'nli kasrlar

35. O'nli kasrlarning yozilishi va o'qilishi.....	155
36. O'nli kasrlarni taqqoslash .....	160
37. O'nli kasrlarni qo'shish va ayirish .....	165
38. Sonning taqribiy qiymati. Sonlarni yaxlitlash .....	170
39. VI bobni takrorlashga doir masalalar .....	175

## VII bob. O'nli kasrlarni ko'paytirish va bo'lish

40. O'nli kasrni natural songa ko'paytirish.....	178
41. O'nli kasrni natural songa bo'lish.....	183
42. O'nli kasrlarni ko'paytirish.....	190
43. O'nli kasrni o'nli kasrga bo'lish .....	196
44. O'rta arifmetik .....	201
45. VII bobni takrorlashga doir masalalar .....	204

## VIII bob. Foizlar

46. Foiz haqida tushuncha .....	208
47. Foizlarga doir masalalar .....	212
48. Burchak. To'g'ri va yoyiq burchaklar.....	217
49. Burchaklarni o'lchash. Transportir.....	222
50. Doiraviy diagrammalar va ularni qurish .....	226
51. VIII bobni takrorlashga doir masalalar .....	230

## IX bob. Takrorlash

52. V sinfdan o'tilganlarni takrorlashga doir masalalar .....	232
<b>Javoblar</b> .....	237

### Darslik saytiga marhamat!

«Matematika 5» darsligini yanada takomillashtirish, unga oid o'quv-uslubiy materiallarni yaratish va boyitib borish maqsadida muallif tomonidan maxsus sayt yaratildi. Saytning «ZiyoNet» tarmog'idagi elektron manzili – matematika5.zn.uz.

Kelajakda bu sayt ta'lim yangiliklari, o'quv-me'yoriy hujjatlar, qo'shimcha nazariy va o'quv-uslubiy materiallar, sinfdan tashqari mashg'ulotlar (to'garak, olimpiada) materiallari, matematika fani tarixiga oid lavhalar hamda qiziqarli masalalar xazinasiga aylantiriladi. Unga o'z materiallaringizni ham qo'shishingiz mumkin.

Sayt yordamida darslikning afzalliklari va kamchiliklari haqida fikr va mulohazalaringizni hamkasblaringiz bilan o'rtoqlashishingiz mumkin. Shuningdek, mazkur darslik asosida dars berish davomida tug'ilgan savollarga muallifning o'zidan javob olishingiz mumkin.

Muallif darslik va sayt haqidagi barcha fikr va mulohazalarni chuqur minnatdorchilik bilan kutib qoladi. Ularni muallifning elektron manzili khaydarov@yahoo.com ga yuborishingiz ham mumkin.

1 2 3

4 5 6

7 8 9



I II III

IV V VI

VII VIII IX



## I BOB. NATURAL SONLAR VA SHKALALAR

1- §.

**NATURAL SON TUSHUNCHASI.**

**NATURAL SONLARNING YOZILISHI VA O'QILISHI**

### 1.1. Natural sonlar qatori

Quyidagi rasmda ikkita olma, uchta daftar va o'nta kitob tasvirlangan. Sonlardan foydalanib bu narsalarni quyidagicha yozish mumkin:



2 ta olma,

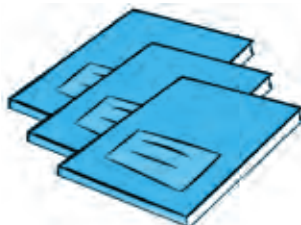

3 ta daftar,



10 ta kitob.

Narsalarni sanashda ishlatiladigan sonlar *natural sonlar* deb ataladi.

Yuqorida ko'rilgan misolda 2, 3 va 10 sonlari natural sonlardir.

Har qanday natural sonni o'nta: 1, 2, 3, 4, 5, 6, 7, 8, 9, 0 raqamlari bilan yozish mumkin. Sonning faqat 0 dan 9 gacha bo'lgan raqamlar bilan bunday yozilishiga *sonning o'nli yozuvi* deyiladi. Bu holda son *o'nli sanoq sistemasida* yozilgan deb ham aytiladi.

1 dan boshlab barcha natural sonlarni sanoq tartibida ketma-ket yozib chiqsak,

**1, 2, 3, 4, 5, 6, 7, 8, 9, 10, 11, 12, 13, 14, 15, 16, 17, ...** ko'rinishdagi *natural sonlar qatori* hosil bo'ladi.

*Natural sonlar qatorida 1 eng kichik natural son*dir.



Har qanday natural songa 1 ni qo'shsak, natural sonlar qatorida undan keyin keluvchi natural son hosil bo'ladi. Shuning uchun natural sonlar qatorida eng katta son yo'q. Chunki, eng katta son bor desak, bu songa 1 ni qo'shib undan ham katta sonni hosil qilaveramiz.

*Natural sonlar qatori cheksizdir.*



Sonning oʻnli yozuvida har bir raqam qiymati uning turgan oʻrniga bogʻliq boʻladi. Agar 7 raqami natural son yozuvining eng oxirida turgan boʻlsa, 7 ta birlikni, oxiridan ikkinchi oʻrinda turgan boʻlsa, 7 ta oʻnlikni, oxiridan uchinchi oʻrinda turgan boʻlsa, 7 ta yuzlikni anglatadi va hokazo.

Masalan, 7 soni 127 yozuvida - 7 ta birlikni, 472 yozuvida - 7 ta oʻnlikni, 780 yozuvida esa - 7 ta yuzlikni anglatadi.

0 raqami oʻzi turgan xonada birorta ham birlik yoʻqligini bildiradi. Bu belgi nol sonini ifodalashda ham ishlatiladi.



0 natural son emas.

## 1.2. Koʻp xonali sonlar, ularning oʻqilishi va yozilishi

Natural son yozuvi bitta belgidan (raqamdan) iborat boʻlsa, bu son - *bir xonali*, ikkita belgidan (raqamdan) iborat boʻlsa, *ikki xonali son* deb ataladi. Shunga oʻxshash, natural sonlar yozuvidagi belgilar (raqamlar) soniga qarab, uch xonali, toʻrt xonali, besh xonali va hokazo koʻp xonali sonlar haqida gapirish mumkin.

Masalan, 1, 3, 6, 9 - bir xonali, 19, 22, 87 - ikki xonali, 307, 976 - uch xonali, 6717, 4500 - toʻrt xonali, 20 456, 56 001 - besh xonali sonlardir.

Ikki va undan ortiq xonali sonlar - *koʻp xonali sonlar* deb ataladi.

Koʻp xonali sonlarni oʻqish uchun ular oʻng tomondan boshlab uchta raqamdan iborat guruhlariga ajratiladi (eng oxirgi guruh bitta yoki ikkita raqamdan iborat boʻlishi ham mumkin). Bu guruhlar *sinflar* deb ataladi.

Oʻng tomondagi birinchi uchta raqam *birlar sinfini*, keyingi uchta raqam *minglar sinfini* tashkil qiladi. Ulardan keyin *millionlar*, *milliardlar* va hokazo sinflar keladi.

1 000 000 - million sonining yozilishi. U qisqacha 1 mln deb ham yoziladi. *Millionlar sinfi* - *millionlar*, *oʻn millionlar* va *yuz millionlar xonasidan* tashkil topgan. Bu xonalarni millionlar sinfining birlar, oʻnlar va yuzlar xonasi deb ham ataymiz. Ravshanki, 1 million mingta 1000 ga teng boʻladi.

1 000 000 000 - milliard sonining yozilishi. U qisqacha 1 mlrd deb ham yoziladi. 1 milliard 1000 ta millionga teng.

*1- misol.* Aytaylik, 29 405 378 613 soni oʻnli yozuv jadvalida yozilgan boʻlsin.

Jadvaldan koʻrinib turibdiki, berilgan sonning milliardlar sinfida 29 ta birlik, millionlar sinfida 405 ta birlik, minglar sinfida 378 ta birlik va nihoyat birlar sinfida 613 ta birlik bor.

Sinflar nomi	milliardlar			millionlar			minglar			birlar		
Sinf xonalari nomi	yuzlar	oʻnlar	birlar	yuzlar	oʻnlar	birlar	yuzlar	oʻnlar	birlar	yuzlar	oʻnlar	birlar
Son		2	9	4	0	5	3	7	8	6	1	3
Oʻqilishi:	29 milliard			405 million			378 ming			613		

Sonni o'qish uchun chapdan o'ngga qarab sonning har bir sinfidagi birliklari soniga shu sinf nomini qo'shib ketma-ket aytib chiqiladi. Eng oxirgi birlar sinfi nomi o'qilmaydi. Agar sinfning har uchala xonasida 0 turgan bo'lsa, bu sinf nomi ham o'qilmaydi.



29 405 378 613 soni – 2 ta o'n milliard, 9 ta bir milliard, 4 ta yuz million, 5 ta bir million, 3 ta yuz ming, 7 ta o'n ming, 8 ta bir ming, 6 ta yuz, 1 ta o'n, 3 ta birdan iborat.

**2- misol.** Quyidagi o'nli yozuv jadvalida yozilgan 247 108 000 394 sonining minglar sinfi faqat nollardan iborat.

Shuning uchun sonni o'qishda bu sinf nomi o'qilmaydi.

Sinflar nomi	milliardlar			millionlar			minglar			birlar		
Sinf xonalari nomi	yuzlar	o'nlar	birlar	yuzlar	o'nlar	birlar	yuzlar	o'nlar	birlar	yuzlar	o'nlar	birlar
Son	2	4	7	1	0	8	0	0	0	3	9	4
O'qilishi:	247 milliard			108 million						394		

Sonlar o'nli yozuv jadvalidan foydalanmasdan o'qilganda quyidagicha yo'l tutiladi:

Berilgan son oldin guruhlarga ajratiladi va guruhlari orasiga bir oz joy tashlab, qayta yozib chiqiladi. So'ng yuqoridagi qoidaga ko'ra o'qiladi.

**3- misol.** 373612400026 soni berilgan bo'lsa, oldin u 373 612 400 026 ko'rinishda qayta yozilib, sinflarga ajratiladi va uch yuz yetmish uch milliard olti yuz o'n ikki million to'rt yuz ming yigirma olti deb o'qiladi.

**4- misol.** Endi o'n ikki milliard olti yuz sakson to'qqiz ming ikki sonini raqamlar bilan yozaylik.

Chapdan o'ngga qarab milliardlar sinfiga 12 ni, millionlar sinfiga 000 ni, minglar sinfiga 689 ni, birlar sinfiga esa 002 ni yozamiz. Bunda millionlar sinfi nomi o'qilmagan bo'lsa-da, unga uchta 0 ni yozamiz. Shunga o'xshash, birlar sinfidagi yuzlar va o'nlar xonasi nomlari o'qilmagan bo'lsa-da, bu xonalarga ham 0 ni yozib qo'yamiz.

Natijada 12 000 689 002 yozuvi hosil bo'ldi.

### Savollarga javob bering!



1. Sonlarni yozishda nechta raqam ishlatiladi? Ularni ayting.
2. Qanday sonlar natural sonlar deb ataladi?
3. Natural sonlar qatorining xossalari ayting.
4. Ko'p xonali sonlar qay tarzda sinflarga ajratiladi?
5. Qanday sinf nomlarini bilasiz?
6. Ko'p xonali sonlar qanday o'qiladi?



## Sinfda bajariladigan mashqlar

1. a) 999 sonidan keyin keluvchi; b) 100 sonidan oldin keluvchi; d) 13 400 sonidan oldin keluvchi; e) 90 999 sonidan keyin keluvchi; f) 8000 sonidan bitta kam; g) 3 299 999 sonidan bitta ko'p bo'lgan natural sonni ayting.
2. Shunday son yozingki, unda quyidagi xona birliklari bo'lsin:
 

a) 5 ta yuz, 2 ta o'n, 4 ta bir;	b) 6 ta yuz, 0 ta o'n, 2 ta bir;
d) 8 ta ming, 3 ta yuz, 2 ta o'n 7 ta bir;	e) 3 ta bir, 2 ta o'n, 9 ta yuz, 1 ta ming;
f) 2 ta yuz, 3 ta bir, 4 ta ming 0 ta o'n;	g) 4 ta o'n, 6 ta ming, 0 ta bir, 3 ta yuz.
3. Sonlarni o'nli yozuv jadvaliga joylang va o'qing:
 

a) 2 402 358;	b) 58 082 743;	d) 102 812 443;	e) 252 700 824 301;
f) 412 000 627;	g) 24 000 003;	h) 123 240 000;	i) 908 100 006 721.

*Namuna:* Yuqorida ko'rilgan 1-, 2-misollar.
4. Sonlarni o'qing.
 

mlrd	mln	ming	bir	
a) 234	509	234	179;	b) 490 324 800;
d) 3	392	000	671;	e) 234 000 999 000.



5. Sonlarni sinflarga ajratib yozing va o'qing:
 

a) 24308512604;	b) 103492001320;	d) 600210334000;	e) 191000054407.
-----------------	------------------	------------------	------------------

*Namuna:* Yuqorida ko'rilgan 3-misol.
6. To'rt xonali, besh xonali va olti xonali sonlarni so'z bilan qog'ozga yozing va uni yoningizda o'tirgan sinfdoshingiz bilan almashing. So'z bilan yozilgan sonlarni raqamlar bilan yozing va qog'ozni sinfdoshingizga qaytaring. Sinfdoshingiz topshiriqni qanday bajarganini tekshiring.
7. Amallarni bajarish tartibini ayting va og'zaki hisoblang:
 

a) $3420 - 40 : 2$ ;	b) $(4532 + 8) : (99\ 998 - 99\ 997)$ ;
d) $200 \cdot 10 : 5$ ;	e) $(200 - 199) \cdot (400 + 1200 : 2)$ .
8. Amudaryoning uzunligi 2540 km. Sirdaryo unga qaraganda 479 km uzun. Sirdaryoning uzunligini toping.
9. Nurali cho'ponda 123 ta, Sherali cho'ponda esa undan 45 ta ko'p qo'y bor. Ikkala cho'ponda jami nechta qo'y bor?
10. Raqamlar bilan yozing:
 

a) 453 ming;	b) 23 mln;	d) 102 mlrd;	e) 12 mlrd 203 mln 2 ming.
--------------	------------	--------------	----------------------------
11. Sonlarni o'nli yozuv jadvalidan foydalanib raqamlar bilan yozing:
 

a) ellik uch;	b) uch ming to'rt yuz qirq bir;	d) o'n ikki million o'ttiz ming sakson besh;	e) bir milliard uch yuz to'rt ming oltmish;	f) to'rt yuz o'ttiz milliard to'qson million;	g) olti yuz ellik milliard besh yuz million ikki yuz uch ming yetti.
---------------	---------------------------------	--	---	---	--







- 22.** Shahardan Obod qishlog'igacha bo'lgan yo'l 23 km bo'lib, u shahardan Ozod qishlog'igacha bo'lgan yo'ldan 4 km uzun. Shahardan Ozod qishlog'igacha bo'lgan yo'l necha kilometr?



- 23.** 517 sonini yonma-yon a) 2 marta; b) 3 marta; d) 4 marta yozing. Hosil bo'lgan sonlarni o'qing va so'zlar bilan yozing.
- 24.** Sonlarni raqamlar bilan yozing: a) o'n uch ming olti yuz oltmish ikki; b) yigirma uch million yetmish ikki ming o'ttiz to'rt; d) ikki milliard besh yuz uch ming oltmish bir; e) yetti yuz sakson milliard to'rt yuz million bir yuz yetti ming olti.
- 25.** a) 12 312 123; b) 33 333 333; d) 202 042 004 soni necha xonali? U nechta belgi bilan yozilgan? Yozuvda nechta turli raqam ishlatilyapti?
- 26.** 531 020, 2 140 530, 909 444 129 008, 2 850 003, 73 302 100, 12 326 751 074, 93 405 002 sonlarini so'zlar bilan yozing va ularning necha xonali ekanligini ayting.
- 27.** 20, 202, 2020, ... sonlar ketma-ketligi qanday qonuniyat asosida yozilgan. Uning keyingi 3 ta hadini yozing va o'qing.



### Matematika tarixiga oid lavhalar

Hozirda dunyoda keng tarqalgan: 1, 2, 3, 4, 5, 6, 7, 8, 9, 0 raqamlari «arab raqamlari» deb atalsa-da, aslida ularning kelib chiqishi hindlarga borib taqaladi. Gap shundaki, bu raqamlarni arablar hindlardan o'zlashtirishgan. 1120- yilga kelib ingliz faylasufi Adelard buyuk bobokalonimiz al-Xorazmiyning arab tilida yozilgan jadvallarini ingliz tiliga tarjima qilgan. Shu-shu, bu raqamlar Yevropada «arab raqamlari» deb foydalanila boshlagan. 1600- yilga kelib esa, bu raqamlar dunyoning ko'plab davlatlariga tarqalgan.



### Qiziqarli matematikaga oid masalalar

1 dan 99 gacha bo'lgan natural sonlar ketma-ket yozilib, uzundan-uzun ulkan son hosil qilindi. Bu sonda 1 raqami necha marta yozilgan? 2 raqami-chi?

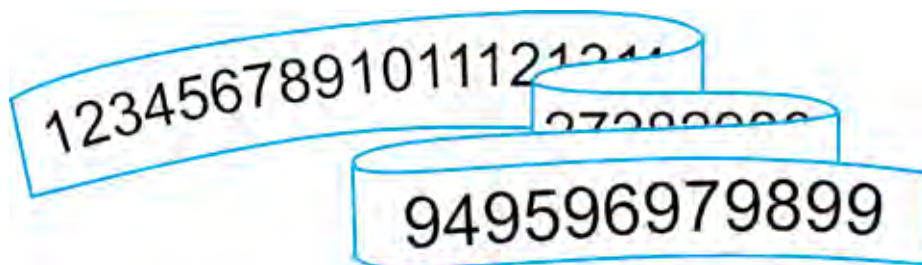

2-§.

**KESMA. KESMANING UZUNLIGI. UCHBURCHAK**

**2.1. Kesma**

Nuqta eng sodda geometrik shakldir. Uni tasvirlash uchun daftarga uchi qalamni tekizish kifoya (1- rasm). Nuqtalar katta lotin harflari bilan belgilanadi. 2- rasmda  $A, B, C, D$  nuqtalari tasvirlangan.

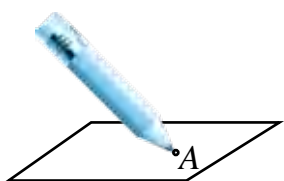

1- rasm

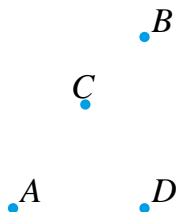

2- rasm

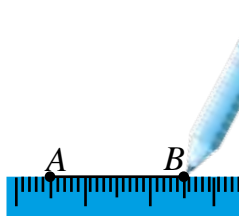

3- rasm

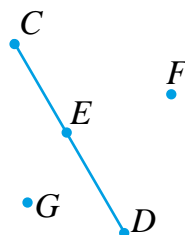

4- rasm

Daftaringizda  $A$  va  $B$  nuqtalarni belgilang. Ularni chizg'ich yordamida tutashtir-sangiz  $AB$  kesma hosil bo'ladi (3-rasm). Uni « $BA$  kesma» deb belgilash ham mumkin.  $A$  va  $B$  nuqtalar  $AB$  kesmaning uchlari deb ataladi.

Istalgan ikki nuqtani faqat bitta kesma bilan tutashtirish mumkin.



4-rasmda  $CD$  kesma tasvirlangan.  $E$  nuqta bu kesmaga tegishli va u  $C$  va  $D$  nuqtalar orasida yotadi.  $F$  va  $G$  nuqtalar esa bu kesmaga tegishli emas, chunki ular bu kesmada yotmaydi.

Kesmalarni sirkul yordamida 5–6-rasmlardagidek taqqoslash mumkin. 5-rasmda  $AB$  va  $MK$  kesmalar teng bo'ladi. Bu  $AB = MK$  tarzda yoziladi.

6-rasmda tasvirlangan  $AB$  kesma  $MK$  kesmaning bo'lagidan iborat. Shuning uchun  $AB$  kesma  $MK$  kesmadan qisqa,  $MK$  kesma esa  $AB$  kesmadan uzun.

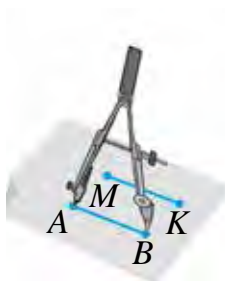

5- rasm

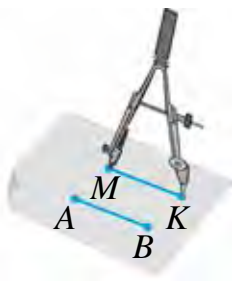

6- rasm

**2.2. Kesmaning uzunligi. Uchburchak**

Har bir kesma tayin uzunlikka ega.



7-rasmda uchta kesma berilgan. Birinchi  $AB$  kesmaning uzunligi 1 sm ga teng.  $AB$  kesma  $MN$  kesmaga roppa-rosa uch marta,  $EF$  kesmaga esa 4 marta joyla-

shadi. Shu bois  $MN$  kesmaning uzunligi 3 sm ga,  $EF$  kesmaning uzunligi esa 4 sm ga teng deb aytamiz va  $MN = 3$  sm,  $EF = 4$  sm tarzda yozamiz.

$MN$  va  $EF$  kesmalarining uzunligini 1 santimetrlik birlik kesma yordamida, ya'ni santimetrlarda o'lchadik. Kesmalarining uzunligini boshqa uzunlik birliklari: millimetr, detsimetr, metr, kilometrlarda ham o'lchash mumkin. 8-rasmda tasvirlangan  $CD$  kesma uzunligi 17 mm ga teng.

Odatda kesmaning uzunligi chizg'ich yordamida o'lchanadi. Shuningdek, chizg'ichdan muayyan uzunlikka ega bo'lgan kesmani yasashda (chizishda) ham foydalaniladi. 9- rasmda uzunligi 23 mm ga teng bo'lgan  $EF$  kesmani chizish jarayoni ko'rsatilgan.

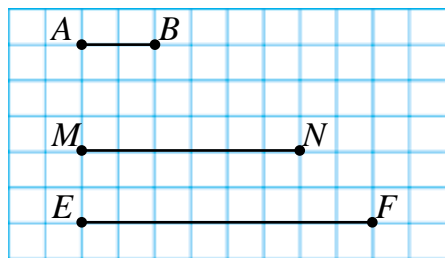

7- rasm

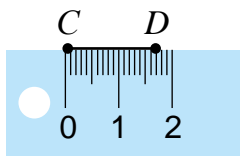

8- rasm

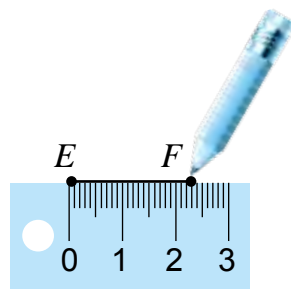

9- rasm

**!** Kesmaning uzunligini o'lchash – unga birlik kesma necha marta joylashishini aniqlashdan iborat.

Uzunlik o'lchov birliklari orasida quyidagi munosabatlar bor:

$$\begin{array}{lll} 1 \text{ sm} = 10 \text{ mm}, & 1 \text{ dm} = 10 \text{ sm}, & 1 \text{ dm} = 100 \text{ mm}, \\ 1 \text{ m} = 10 \text{ dm}, & 1 \text{ m} = 100 \text{ sm}, & 1 \text{ km} = 1000 \text{ m}. \end{array}$$

10-rasmda tasvirlangan  $AB$  kesmada olingan  $C$  nuqta uni  $AC$  va  $CB$  qismlarga ajratadi. Bu holda  $AB$  kesmaning uzunligi uning qismlari  $AC$  va  $CB$  kesmalar uzunliklarining yig'indisidan iborat bo'ladi va

$$AB = AC + CB$$

tarzda yoziladi.

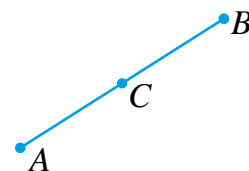

10- rasm

**!** Kesmaning uzunligi uning uchlarini tutashtiruvchi ixtiyoriy chiziq uzunligidan qisqaroq bo'ladi.

$AB$  kesma uzunligini  $A$  va  $B$  nuqtalar orasidagi masofa deb ham aytishadi.

Bir to'g'ri chiziqda yotmaydigan  $A$ ,  $B$  va  $C$  nuqtalarni daftarda belgilab ularni kesmalar bilan tutashtirib chiqsak, *uchburchak* hosil bo'ladi va u « $ABC$  uchburchak» tarzda ifodalanadi (11-rasm).

$A$ ,  $B$  va  $C$  nuqtalar  $ABC$  uchburchakning uchlari,  $AB$ ,  $BC$ ,  $AC$  kesmalar esa uchburchakning tomonlari deb ataladi.

Uchburchak tomonlari uzunliklari yig'indisi uchburchak perimetri deb ataladi.

12-rasmda  $MNLK$  to'rtburchak tasvirlangan.  $M$ ,  $N$ ,  $L$  va  $K$  nuqtalar to'rtburchakning uchlari,  $MN$ ,  $NL$ ,  $LK$  va  $KM$  kesmalar uning tomonlaridan iborat.

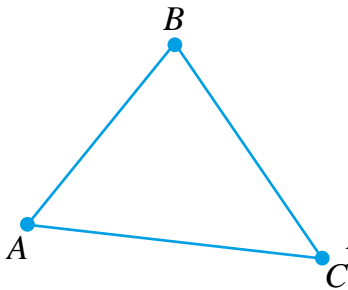

11- rasm

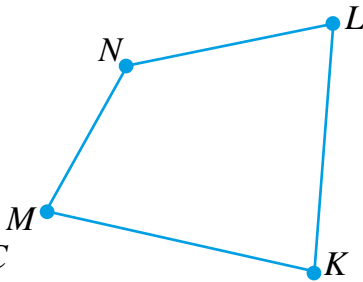

12- rasm

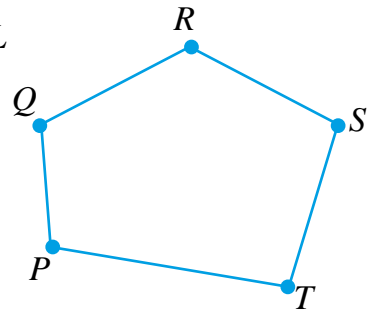

13- rasm

To'rtburchakning perimetri uning barcha tomonlari yig'indisidan iborat bo'ladi. 13-rasmda  $PQRST$  beshburchak tasvirlangan.

Uchburchak, to'rtburchak, beshburchak va hokazo shakllar umumiy nom bilan *ko'pburchak* deb ham ataladi.

### Savollarga javob bering!



1. Kesma qanday chiziladi?
2.  $A$  va  $B$  nuqtalarni nechta kesma bilan tutashtirish mumkin?
3. Ikkita kesma bir-biri bilan qanday taqqoslanadi?
4. Kesmaning uzunligi qanday o'lchanadi?
5. Qanday uzunlik o'lchov birliklarini bilasiz?
6. Uchburchak qanday chiziladi?
7. Ko'pburchakning perimetri qanday topiladi?

### Sinfda bajariladigan mashqlar



28. Daftaringizda ikkita nuqta chizing. Ularni  $P$  va  $Q$  harflar bilan belgilang va chizg'ich yordamida tutashtiring. Hosil bo'lgan kesmani yozing.

29. 14- rasmda tasvirlangan barcha kesmalarni ayting.

a)



14- rasm

b)

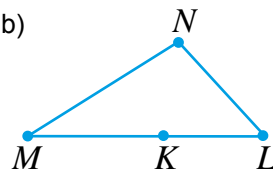

30. 15- rasmdagi qaysi nuqtalar  $CD$  kesmaga tegishli? Qaysi nuqtalar bu kesmaga tegishli emas?  $CD$  kesmadagi  $K$  nuqta uning berilgan qaysi nuqtalari orasida yotadi?

31. 16- rasmdagi  $KL$  kesmani sirkul yordamida qolgan kesmalar bilan taqqoslang. Bu kesma qaysi kesmalardan uzun? Qaysi kesmalardan qisqa?

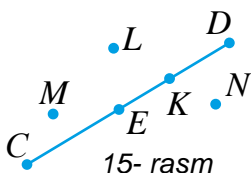

15- rasm

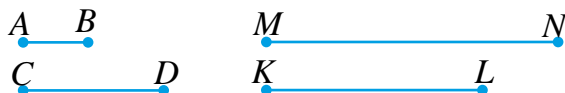

16- rasm

**32.** 16- rasmdagi  $AB$  kesmani birlik kesma (ya'ni uzunligini 1 ga teng) deb olib, qolgan kesmalar uzunliklarini sirkul yordamida toping.

**33.** Amallarni bajaring:

a)  $1420 - 40 : 2$ ;

b)  $(232 + 8) : 10 + 124$ ;

d)  $121 : 11 + 12 \cdot 10$ ;

e)  $(203 - 199) \cdot 100 + 120 : 2$ .

**34.** 3 raqami ishtirok etgan barcha ikki xonali sonlarni yozing.

**35.** Omborda 345 t kartoshka bor edi. Birinchi haftada 27 t, ikkinchi haftada esa birinchi haftaga qaraganda 8 t kam kartoshka sotuvga chiqarildi. Omborda necha tonna kartoshka qoldi?



**36.** Sxema asosida quyidagi savollarga javob bering:



a) 1 santimetr necha millimetr?

b) 1 detsimetr necha santimetr?

d) 1 metr necha millimetr?

e) 1 kilometr necha detsimetr?

**37.** Santimetrda ifodalang:

a) 5 dm 8 sm;      b) 3 dm 3 sm;      d) 23 dm 8 sm;      e) 11 dm 4 sm.

*Namuna:* 6 dm 2 sm = 60 sm + 2 sm = 62 sm.

**38.** Detsimetr va santimetrlarda ifodalang:

a) 23 sm;      b) 63 sm;      d) 39 sm;      e) 214 sm.

*Namuna:* 78 sm = 70 sm + 8 sm = 7 dm 8 sm.

**39.** Og'zaki hisoblang:

a)  $16 + 77$ ;

b)  $58 - 26$ ;

d)  $55 + 35$ ;

e)  $35 + 39$ ;

f)  $4 \cdot 202$ ;

g)  $100 \cdot 600$ ;

h)  $205 : 5$ ;

l)  $444 : 6$ .

**40.** Hadichaning 2500 so'm puli bor edi. U 500 so'mga daftar va 600 so'mga muzqaymoq sotib oldi. Hadicha necha so'mlik xarid qilgan? Uning yana qancha puli qoldi?

**41.** Uydan kinoteatrgacha bo'lgan masofa 1200 m, uydan maktabgacha bo'lgan masofa esa 850 m. Uydan maktabgacha bo'lgan masofa kinoteatrgacha bo'lgan masofadan necha metr qisqa?



**42.** Quyidagi kesmalar uzunligini chizg'ich yordamida o'lchang.



**43.** Rasmda tasvirlangan  $AB$  kesma uzunligini toping.  $AB$  kesma uzunligini chizg'ich yordamida o'lchab natijani tekshiring.

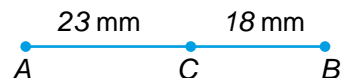

**44.**  $AB$  kesmani  $C$  va  $D$  nuqtalar ketma-ket kelgan  $AC$ ,  $CD$  va  $DB$  qismlarga ajratadi. Agar  $AC$  kesmaning uzunligi 21 mm,  $CD$  kesma  $AC$  kesmadan 6 mm uzun,  $DB$  kesma esa  $CD$  dan 7 mm qisqa bo'lsa,  $AB$  kesmaning uzunligini toping.

45. **Amaliy mashg'ulot.** a) Chizg'ich yordamida daftar, kitob va partaning bo'yi va enini o'lchang; b) Chizg'ich yordamida qarichingizning uzunligini 17- rasmda ko'rsatilganidek o'lchang.

Qarichingiz uzunligini yodda tuting!



17-rasm

46. Daftaringizga uchburchak chizing va uni belgilang. Uning uchlari va tomonlarini mos belgilar bilan yozing. Uchburchak tomonlari uzunliklarini chizg'ich yordamida o'lchang va uning perimetrini toping.

47. Ko'pburchaklarni daftaringizga chizing va belgilang. Chizg'ich yordamida ularning tomonlari uzunliklarini millimetrdagi o'lchang va perimetrini toping.

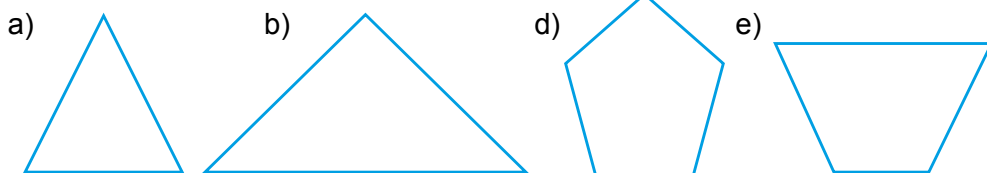

48. Amallarni bajaring:

a)  $(3568 + 232) : 2$ ;    b)  $(592 + 8) : 12$ ;    d)  $21 \cdot 12 - 135$ ;    e)  $19 \cdot 41 + 312$ .

- 49.



**Uyda bajariladigan mashqlar**



50.  $AB$  kesma chizing. Unga tegishli  $C$  va  $D$  nuqtalarni belgilang. Bu nuqtalar  $AB$  kesmani qanday kesmalarga ajratadi?
51.  $A, B, C, D$  va  $O$  nuqtalarni daftaringizga belgilang.  $O$  nuqtani qolgan nuqtalarning har biri bilan kesmalar yordamida tutashtiring. Hosil bo'lgan kesmalarni yozing.
52. Quyidagi rasmda berilgan kesmalar orasidan eng uzunini va eng qisqasini sirkul yordamida aniqlang.  $MN$  kesma qaysi kesmalardan uzun va qaysi kesmalardan qisqa ekanligini aniqlang.

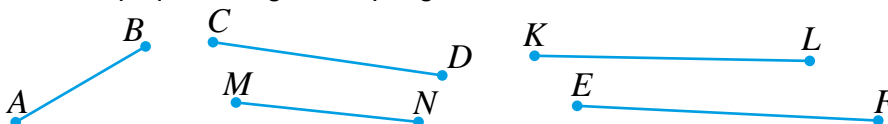

53. 36-masalada keltirilgan sxema asosida quyidagi savollarga javob bering:
- a) 10 santimetr necha millimetr?    b) 5 detsimetr necha millimetr?  
 d) 6 metr necha detsimetr?    e) 2 kilometr necha millimetr?
54. Millimetrdagi ifodalang:
- a) 5 sm 9 mm;    b) 4 dm 6 sm 7 mm;    d) 9 dm 2 sm.



55. Santimetr va millimetrlarda ifodalang:  
 a) 438 mm;      b) 907 mm;      d) 223 mm;      e) 768 mm.

56.  $AB$  kesmani  $C$  nuqta  $AC$  va  $CB$  qismlarga ajratadi. Agar  $AC$  kesmaning uzunligi 56 sm bo'lib, u  $CB$  kesmadan 23 sm qisqa bo'lsa,  $AB$  kesmaning uzunligini toping.
57.  $AB$  kesmani  $C$  va  $D$  nuqtalar ketma-ket kelgan  $AC$ ,  $CD$  va  $DB$  qismlarga ajratadi. Agar  $AC$  kesma uzunligi 34 mm,  $CD$  kesma  $AC$  kesmadan 12 mm qisqa,  $DB$  kesma esa  $AD$  dan 25 mm qisqa bo'lsa,  $AB$  kesma uzunligini toping.
58.  $ABC$  uchburchakda: a)  $AB = 12$  sm,  $BC = 32$  sm,  $AC = 28$  sm; b)  $AB = 5$  dm,  $BC = 3$  dm,  $AC = 4$  dm; d)  $AB = 43$  mm,  $BC = 5$  sm,  $AC = 38$  mm bo'lsa, uning perimetrini toping.



### Matematika tarixiga oid lavhalar

#### O'lkamizda qadimda ishlatilgan o'lchov birliklari

O'rta Osiyo hududida qadimda turli o'lchov birliklari ishlatilgan. Hozirda bu o'lchov birliklari eskirib, deyarli qo'llanilmaydi. Shunday bo'lsada, qari otaxonlar tilida, tarixiy kitoblarda va badiiy asarlarda bu o'lchov birliklari uchrab turadi.

Masalan, Zahiriddin Muhammad Boburning «Boburnoma» asarida, turli yurtlarning o'lchov birliklari keltirilgan. Quyida ularning ba'zilari va ularning hozirgi o'lchov birliklaridagi qiymatlari keltirilgan:

Uzunlik o'lchov birliklarilari sifatida qadam (taqriban 70–75 sm), qarich (19–22 sm), quloch (166–170 sm), barmoq (2 sm), tirsak (50–80 sm), gaz (70 sm), chaqirim (900 m), yig'och (8 km), qari (55 sm) va musht (8 sm) kabilar ishlatilgan.

Massani o'lchash uchun misqol (taqriban 4 g), qadoq (410 g), pud (16 kg 380 g), botmon (163 kg 800 g) kabi o'lchov birliklari qo'llanilgan.



### Qiziqarli matematikaga oid masalalar

#### O'z ko'zingizga ishonasizmi?

Quyida qizg'ish rangda berilgan kesmalar juftini ko'z bilan chamalab taqqoslang. Ulardan qaysi biri uzun? Endi bu kesmalar uzunliklarini chizg'ich bilan o'lchab taqqoslang. Xo'sh, xulosa qanday bo'ldi?

Shunaqa, *har doim ham ko'zga ishonaverish kerak emas!*

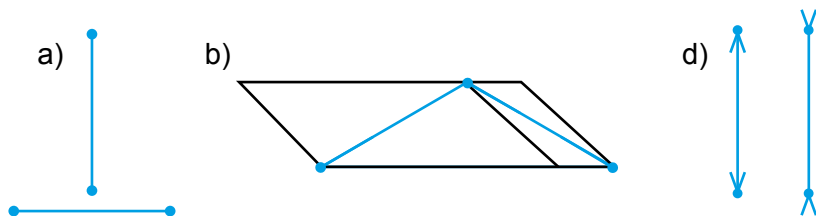



3-§.

TEKISLIK, TO'G'RI CHIZIQ VA NUR

Daftarda juda uzun kesmalarni chizishning imkoni yo'q. Buning uchun, chiziladigan kesmaning kattaligiga qarab, daftarning o'lchamlari maktab doskasi, pol, devor yoki futbol stadioni kattaligida bo'lishi kerak bo'ladi. Keltirilgan bu sirtlarning barchasi chegaralangan bo'lib, ular bizga faqat tekislikning ma'lum bir bo'lagi haqida tasavvurni beradi.

Tekislikning esa chegarasi yo'q u cheksizdir. Shu bois, tekislikni tasvirlashning iloji yo'q. Uni faqat tasavvur qilish mumkin. Tekislikda istalgan uzunlikdagi kesmani chizish, uni chizg'ich yordamida har ikki tomonga istalgancha davom ettirish mumkin.

Keling, chizg'ich yordamida tekislikda berilgan  $AB$  kesmani uning har ikki uchi tomonga istalgancha davom ettiraylik (1-rasm). Natijada, *to'g'ri chiziq* hosil qilamiz. U « $AB$  to'g'ri chiziq» yoki « $BA$  to'g'ri chiziq» tarzda ifodalanadi.

To'g'ri chiziqning cheki (oxiri) yo'q. U har ikki uchi tomonga cheksiz davom etgan. !

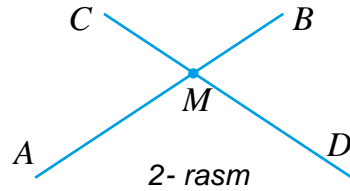
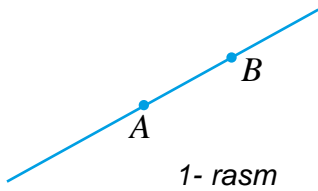

Tekislikda  $A$  va  $B$  nuqtalar berilgan bo'lsin (1-rasm). Chizg'ich yordamida bu nuqtalardan o'tuvchi to'g'ri chiziq o'tkazamiz. Bu nuqtalardan yana bitta to'g'ri chiziq o'tkazishning iloji yo'q.

Har qanday ikki nuqtadan faqat bitta to'g'ri chiziq o'tkazish mumkin. !

Agar ikki to'g'ri chiziq umumiy nuqtaga ega bo'lsa, ular bu nuqtada *kesishadi* deyiladi (2-rasm).  $M$  nuqta  $AB$  va  $CD$  to'g'ri chiziqlarning *kesishish nuqtasi* boladi.

$AB$  to'g'ri chiziqda olingan  $O$  nuqta uni ikki bo'lakka ajratadi (3-rasm). Bu bo'laklarning har biri,  $O$  nuqta bilan birgalikda *nur* deb ataladi.  $O$  nuqta *nurning uchi (boshi)* deb ataladi.

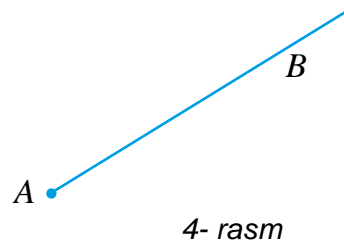
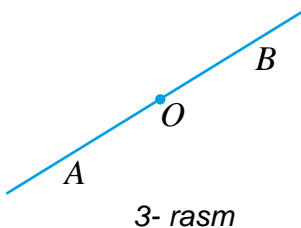

Nurning oxiri (cheki) yo'q. !

4-rasmdagi nur bosh lotin harflari bilan  $AB$  tarzda belgilanadi va « $AB$  nur» deb o'qiladi. Bu yozuvda nurning uchi belgilangan  $A$  harfi har doim birinchi bo'lib yoziladi va o'qiladi.



### Savollarga javob bering!

1. Tekislik haqida tasavvur beradigan bir necha narsalarni ayting?
2. To'g'ri chiziqning cheki (oxiri) bormi?
3. Ikki nuqtadan nechta to'g'ri chiziq o'tkazish mumkin?
4. Ikki to'g'ri chiziq qachon bir-biri bilan kesishadi?
5.  $CD$  to'g'ri chiziqda olingan  $O$  nuqta uni qanday nurlarga ajratadi?



### Sinfda bajariladigan mashqlar

59. 5- rasmda tasvirlangan nuqtalarning qaysilari: a)  $AB$  kesmada; b)  $AB$  to'g'ri chiziqda yotadi? Qaysilari  $AB$  kesmada yotmaydi?

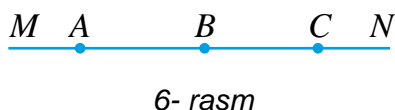
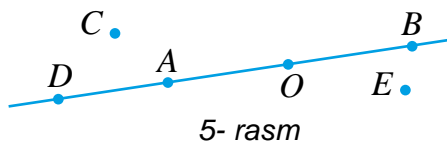

60. Daftaringizga  $MN$  kesma chizing.  $MN$  kesmani uning har ikki uchi tomonga davom ettiring.  $MN$  to'g'ri chiziqda yotgan  $A$  va  $B$  hamda unda yotmagan  $C$  va  $D$  nuqtalarni belgilang. Hosil bo'lgan to'g'ri chiziqni yana qanday belgilash mumkin?

61. 6- rasmda tasvirlangan barcha to'g'ri chiziq va nurlarni ayting.

62. 7- rasmda tasvirlangan  $AB$ ,  $CD$  va  $OE$  nurlarning qaysilari o'zaro kesishadi? Qaysilari o'zaro kesishmaydi?

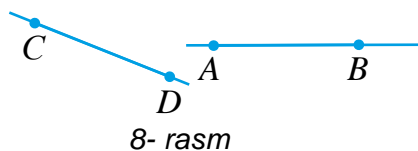
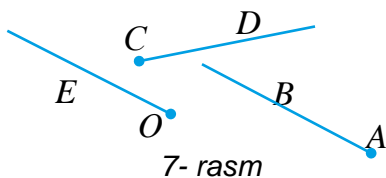

63. 8- rasmda tasvirlangan quyidagi shakllar o'zaro kesishadimi?

- |                                     |  |
|-------------------------------------|--|
| a) $AB$ va $CD$ kesmalar;           | b) $BA$ va $DC$ nurlar;                        |
| d) $AB$ kesma va $DC$ nur;          | e) $AB$ nur va $CD$ kesma;                     |
| f) $AB$ to'g'ri chiziq va $DC$ nur; | g) $AB$ to'g'ri chiziq va $CD$ to'g'ri chiziq. |

64. Kesishuvchi ikki to'g'ri chiziq tekislikni necha bo'lakka ajratadi?

65. Daftaringizga  $PQR$  uchburchak chizing.  $PQ$ ,  $QR$  va  $RP$  to'g'ri chiziqlar tekislikni necha bo'lakka ajratadi?

66. Metr, detsimetr va santimetrlarda ifodalang:

- |            |             |           |             |
|------------|-------------|-----------|-------------|
| a) 223 sm; | b) 1852 sm; | d) 59 sm; | e) 3783 sm. |
|------------|-------------|-----------|-------------|

## Uyda bajariladigan mashqlar



67. 9- rasmda tasvirlangan barcha to'g'ri chiziq va nurlarni yozing.



9- rasm

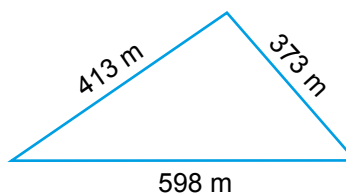

10- rasm

68.  $M$  nuqtani belgilang.  $MN$  va  $ML$  nurlarni chizing. Bu nurlarning uchi qaysi nuqta bo'ladi?
69. Bir-biri bilan kesishuvchi uchta to'g'ri chiziq chizing. Ular tekislikni ko'pi bilan necha bo'lakka ajratadi?
70. 10- rasmda tasvirlangan uchburchak shaklidagi yer maydonini ikki qator sim bilan o'rash uchun necha metr sim kerak bo'ladi?

## Matematika tarixiga oid lavhalar



Angliyada uzoq yillar uzunlik o'lchov birliklari sifatida duym va fut qo'llanilgan. 1 duym taxminan 25 mm ga teng bo'lib, uning nomi inglizcha «bosh barmoq bo'g'ini» nomidan olingan. Fut esa «tovon» nomidan kelib chiqqan va taxminan 30 sm 5 mm ga teng deb olingan: 1 fut = 12 duym.

Hozirda ham bu o'lchov birliklari ayrim hollarda ishlatiladi. Masalan, televizor, kompyuter, noutbuk, qo'l telefoni, smartfonlar monitori diagonalining o'lchovi duymlarda o'lchanadi.

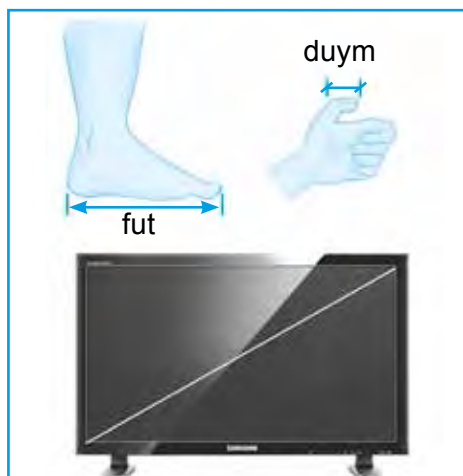

## Qiziqarli matematikaga oid masalalar



Har ikki qatordagi o'rtada, qavs ichida yozilgan son ikki chekkada turgan sonlardan ma'lum arifmetik amal yordamida hosil qilingan. «?» belgisi o'rniga tushirib qoldirilgan sonni yozing:

- a) 42 (47) 5      b) 6 (66) 11      d) 36 (25) 11      e) 48 (4) 12  
 31 (?) 8      5 (?) 12      48 (?) 12      100 (?) 5

4-§.

SHKALALAR VA KOORDINATALAR. SONLAR NURI

4.1. Shkalalar

Yog'ochdan ishlangan yassi tekis reyka yordamida  $A$  va  $B$  nuqtalarni tutashtirib kesma chizish mumkin (1-rasm). Lekin, bu asbob yordamida kesmaning uzunligini o'lchab bo'lmaydi. Buning uchun asbobni yanada takomillashtiramiz.

Uning yuqori chetiga har bir santimetrdan keyin tik chiziqchalar chizib chiqamiz (1- rasm). Chiziqchalar ostiga 0 dan boshlab, 1, 2, 3 va hokazo sonlarni tartib bilan yozib chiqamiz.

Natijada, chiziqcha va sonlardan iborat shkala hosil qilamiz. Bu holda, reyka bitta bo'lmasining qiymati (uzunligi) 1 sm bo'lgan *shkala* tushirilgan deb aytishadi.

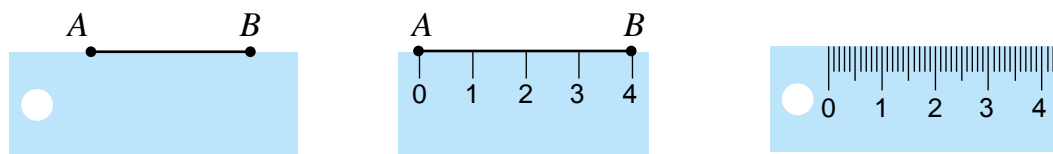

1- rasm

Oddiy chizg'ichni olib qaraydigan bo'lsak (1- rasm), unga bo'lmasining qiymati (uzunligi) 1 mm bo'lgan shkala tushirilgan.

Kundalik turmushda turli shkalalarga duch kelgansiz. Masalan, bo'lmasining qiymati 1 minut bo'lgan soat shkalasi (2.a- rasm).

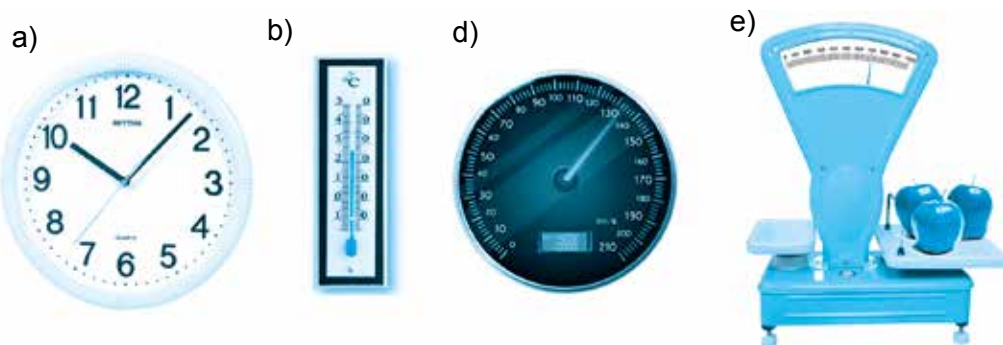

2- rasm

2.b- rasmda tasvirlangan havo haroratini o'lchaydigan asbob – xona termometri shkalasi – Selsiy shkalasi deb nomlanadi. Uning har bir bo'lmasi qiymati 1 gradus ( $1^{\circ}\text{C}$ ) ga teng. Termometr  $25^{\circ}\text{C}$  ni ko'rsatyapti.

2.d- rasmda avtomobil tezligini o'lchaydigan asbob - spidometr shkalasi tasvirlangan. Uning bitta bo'lmasining qiymati 2 km/soatga teng.

2.e- rasmda tasvirlangan tarozi shkalasiga qarab 3 ta olmaning massasi 700 gramm (g) ekanligini aniqlash mumkin.

Massaning kilogramm (kg), tonna (t), sentner (sr) kabi o'lchov birliklari ham bo'lib, ular bir-biri bilan quyidagi tengliklar bilan bog'langan:

$$1 \text{ kg} = 1000 \text{ g}, \quad 1 \text{ sr} = 100 \text{ kg}, \quad 1 \text{ t} = 1000 \text{ kg}.$$

## 4.2. Sonlar nuri

Boshi  $O$  nuqtada bo'lgan, chapdan o'ngga qarab gorizontol yo'nalgan  $OX$  nurni chizamiz (3- rasm). Bu yo'nalishni nur tasvirining o'ng tomoniga qo'yilgan strelka ko'rsatib turibdi. Bu nurda biror  $E$  nuqtani belgilaymiz. Hosil bo'lgan  $OE$  kesmani *birlik kesma* sifatida olamiz.

Nurning boshi  $O$  nuqta tagiga 0 sonini,  $E$  nuqta tagiga esa 1 sonini yozamiz. Bu holda,  *$E$  nuqta  $OX$  nurda 1 sonini tasvirlaydi.*

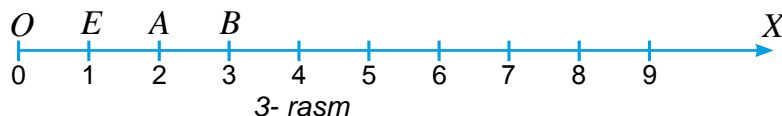

$OX$  nurda 2 sonini tasvirlash uchun nurga birlik kesmani  $O$  nuqtadan ketma-ket ikki marta qo'yamiz. Hosil bo'lgan  $A$  nuqta nurda 2 sonini tasvirlaydi. Agar nur boshidan birlik kesmani uch marta ketma-ket qo'ysak, 3 sonining nurdagi tasviri  $B$  nuqtani hosil qilamiz va hokazo.

Nurning oxiri bo'lmagani uchun unda istalgan natural sonni nurda yuqoridagi usuldan foydalanib tasvirlash mumkin. Natijada, cheksiz shkalani hosil qilamiz. Bu shkala *sonlar nuri* yoki *koordinatalar nuri* deb ataladi.

$O, E, A, B$  nuqtalarga mos kelgan 0, 1, 2, 3 sonlari bu *nuqtalarning koordinatalari* deb ataladi va bu  $O(0), E(1), A(2), B(3)$  tarzida yoziladi.

Ko'rib turganingizdek, strelka yo'nalishida nuqtalarning koordinatalari o'sib boradi va aksincha, strelkaga qarama-qarshi yo'nalishda nuqtalarning koordinatalari kamayib boradi.

Sonlar nurida har qanday natural son nuqta bilan tasvirlanib, o'zining muayyan o'rniga ega.



## 4.3. Ustunli diagrammalar

Shkalalardan ustun shaklidagi diagrammalarni tuzishda ham foydalaniladi. Ustunli diagrammalar turli ma'lumotlarni o'zaro taqqoslash va ko'rgazmali qilib tasvirlashda ishlatiladi.

*Misol.* Jadvalda berilgan ma'lumotlar asosida ustunli diagramma tuzing.

A'lochi o'quvchilar haqida ma'lumot

Sinflar	5- «A»	5- «B»	5- «D»
A'lochi o'quvchilar soni	8	6	5

**Yasash:** Diagrammani uchta ustundan iborat qilib tuzamiz. Bu ustunlar, mos ravishda, 5- «A», 5- «B» va 5- «D» sinfdagi a'lochi o'quvchilar sonini aniqlasin. A'lochi o'quvchilar sonini ko'rsatuvchi shkalani tik holatda chizamiz.

A'lochi o'quvchilar sonidan kelib chiqib, bo'yi mos balandlikka ega bo'lgan to'g'ri to'rtburchak shaklidagi ustunlarni shkala yoniga ketma-ket chizamiz. Hosil bo'lgan shakl (4- rasm) – a'lochi o'quvchilar sonini ko'rgazmali qilib ifodalovchi *ustunli diagrammadan* iborat bo'ladi.

Ba'zida ustunlar o'rniga tegishli shakl yoki rasmlarni ham qo'yish mumkin.

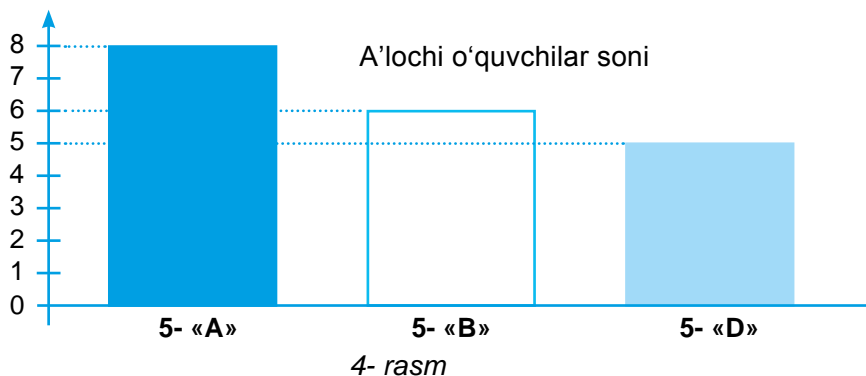

4- rasm



### Savollarga javob bering!

1. Chizg'ich shkalasi nimalardan tashkil topgan?
2. Shkalali o'lchov asboblariga misollar keltiring.
3. Sonlar nuri qanday tuziladi?
4. Nuqtaning sonlar nuridagi koordinatasi qanday aniqlanadi?



### Sinfda bajariladigan mashqlar

**71.** 2- rasmda tasvirlangan asboblar yordamida qanday kattaliklar o'lchanadi? Har bir asbob bitta bo'lmasining qiymati nimaga teng? O'lchanayotgan kattaliklar qiymatini toping.

**72.** 5- rasmdagi termometrlar qanday haroratni ko'rsatyapti?

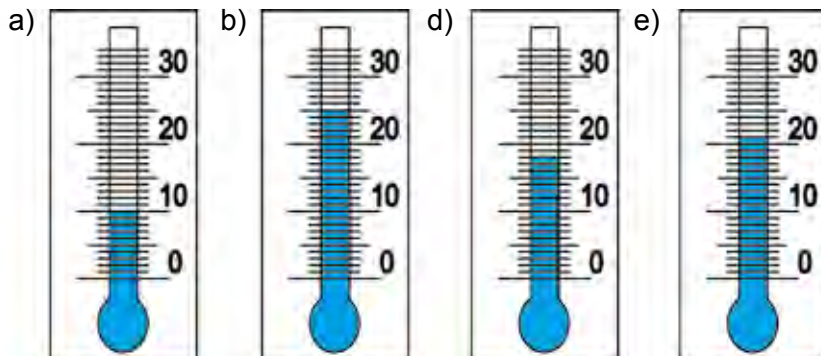

5- rasm

73. 6- rasmdagi avtomobil spidometri shkalasining bo'limasi qiymatini aniqlang. Spidometr yordamida nima o'lchanadi? Ular nimani ko'rsatmoqda?



6- rasm

74. Quyidagi shkalalarning bitta bo'limasi qiymatini aniqlang:

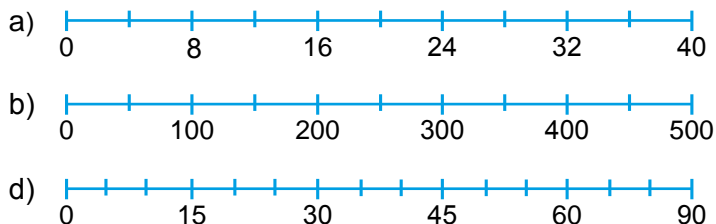

75. Rasmda tasvirlangan telefon, yoqilg'i quyish shoxobchasi, tibbiy yordam punkti, oshxona, dam olish maskani va mehmonxona yo'lining qaysi kilometrida joylashganligini aniqlab, mos nuqtalar koordinatalarini yozing.



76. Sonlar nuri bo'limasining qiymatini toping. Belgilangan nuqtalarga qaysi sonlar mos kelishini aniqlang va ularning koordinatasini yozing.

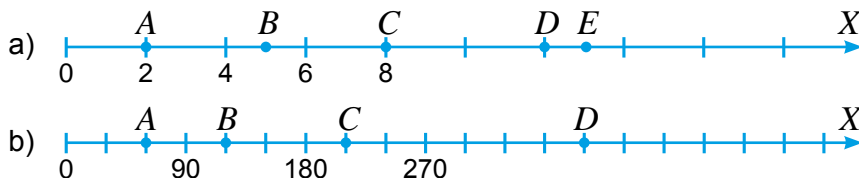

77. Birlik kesma uzunligini 1 sm deb olib, sonlar nurini chizing. Unda koordinatalari 2; 4; 7; va 12 bo'lgan nuqtalarni belgilang.

78. Grammda ifodalang:

- a) 2 kg 453 g;    b) 1 kg 810 g;    d) 2 sr 20 kg 349 g;    e) 5 sr 14 kg 25 g.

79. Kilogramm va grammlarda ifodalang:

- a) 7532 g;    b) 2350 g;    d) 52 345 g;    e) 127 532 g.

**80.** Sentner va kilogrammlarda ifodalang:

- a) 2340 kg;      b) 75 207 kg;      d) 123 320 kg;      e) 10 020 kg.

**81.** Kimning vazni qancha? Quyidagi rasmda chizilgan mushuk, odam, sigir, fil, karkidon va it vaznini chamalab, berilgan kilogrammlarni ularga mos qo'ying.

5 kg, 6000 kg, 3000 kg,  
300 kg, 25 kg, 70 kg

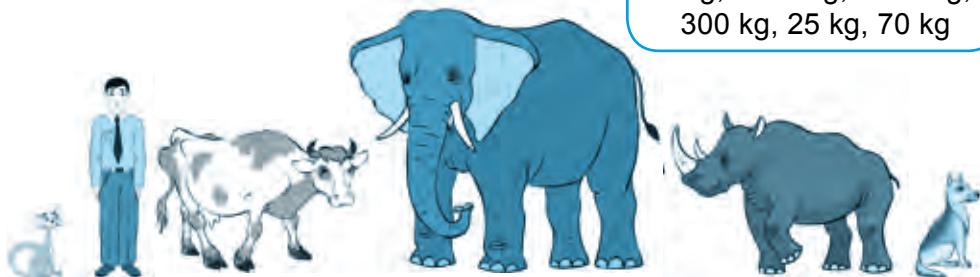

**82.** Matematika kechasida Hoshimjon yig'ilganlarni kuldirish maqsadida baliq oviga borgani haqida hikoya qilib berdi. U hikoyasida o'lchov birliklarini ataylab chalkashtirib aytdi. Hikoyada Hoshimjon yo'l qo'ygani xatolarni aniqlang va ularni tuzatib hikoyani qayta so'zlab bering.

### Baliq ovida

Men ertalab uyg'onib soatga qarasam, vaqt 4 kg 15 gramm bo'libdi. Darrov yuz qo'limni yuvdim va nonushtada 1 kilometr sut ichib oldim. Kun salqin, 12 soat issiq edi. Ko'l tomon yo'lga chiqdim. Men 2 litr tezlik bilan yurdim va 4 gradus yo'l bosdim. Ko'lga 2 metrda yetib keldim. Tezda baliq ovlashga kirishdim. 20 santimetr vaqt o'tib birinchi baliq qarmoqqa ilindi. Uning uzunligi 50 minut, massasi esa 4 kilometr edi. Men baliq ovidan mamnun bo'lib uyga qaytdim.



**83.** Jadvalni to'ldiring:

1- qo'shiluvchi	234		1569
2- qo'shiluvchi	258	342	
Yig'indi		12670	15890

**84.** Temir-tersak yig'ishda uchta sinf qatnashib, 5- «A» sinf – 6 tonna, 5- «B» sinf – 5 tonna va 5- «D» sinf o'quvchilari – 8 tonna temir-tersak yig'di. Bu ma'lumotlar asosida ustunli diagramma tuzing.



85. Quyidagi jadvalda berilgan ma'lumotlar asosida ustunli diagramma tuzing.  
Terilgan paxta haqida ma'lumot

Dehqon xo'jaliklari	«Baraka»	«Bo'ston»	«Istiqlol»
Terilgan paxta (tonnada)	70	55	90

86. Diagrammadan foydalanib dunyodagi osmono'par binolar balandligini toping.

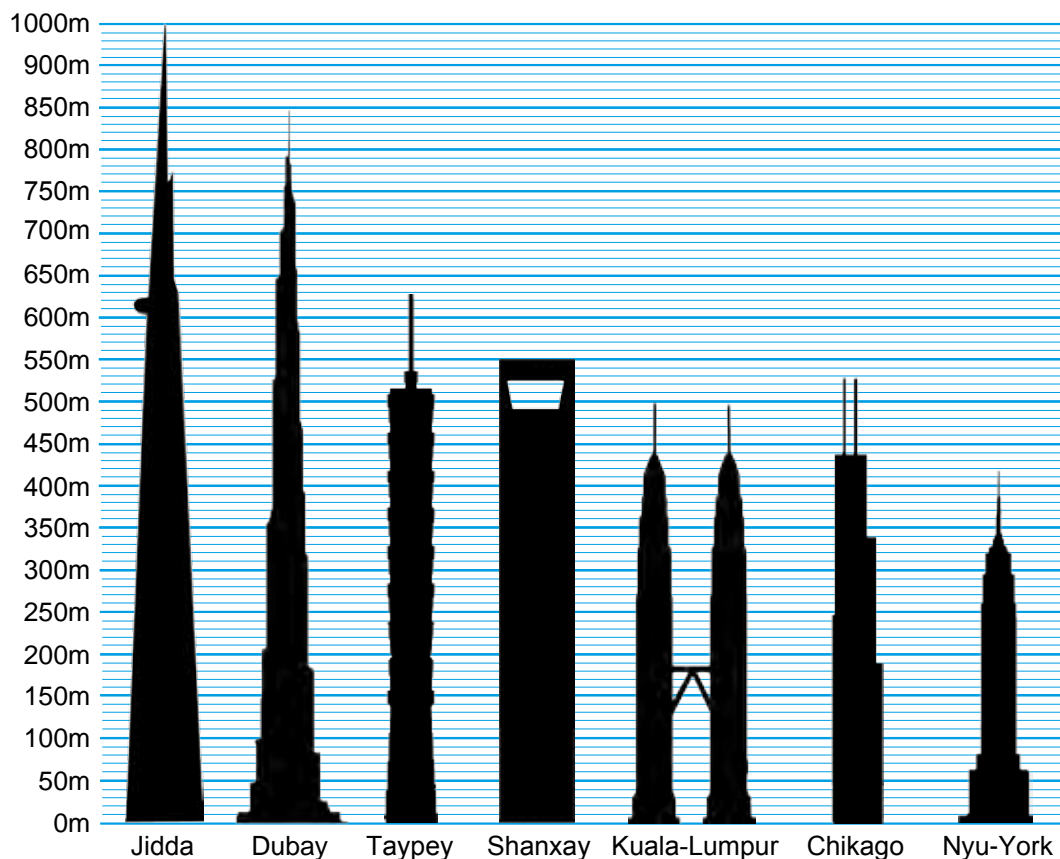

### Uyda bajariladigan mashqlar



87. Quyidagi rasmda yo'l shkala ko'rinishda tasvirlangan. Shkalaning bitta bo'limi qiymatini aniqlang va yetishmayotgan sonlarni yozing.



88. Sonlar nurida belgilangan nuqtalarning koordinatalarini toping.

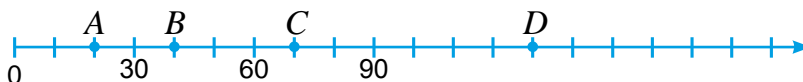

89. 7-rasmdagi termometr ertalab qanday haroratni ko'rsatyapti? Agar havo harorati tushda ertalabkidan 12 bo'lмага (gradusga) ko'tarilgan, kechga borib esa tushdagidan 8 bo'lмага (gradusga) pasaygan bo'lsa, havo harorati tushda va kechqurun qanday bo'lgan?
90. Birlik kesma uzunligini bitta daftar katagi eniga teng deb olib, sonlar nurini chizing. Unda koordinatalari 4; 8; 15; va 24 bo'lgan nuqtalarni belgilang.

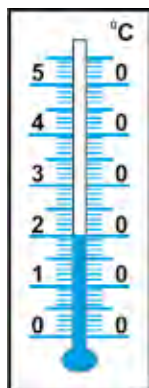

7- rasm

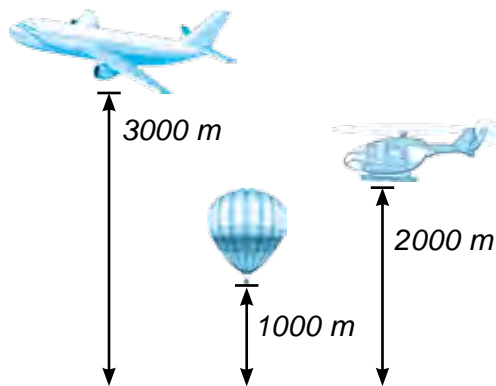

8- rasm

91. Ko'klam va Ko'rkam qishloqlari orasidagi masofa 20 km. Bu qishloqlar orasidagi yo'lni shkala ko'rinishida ifodalang. Birlik kesmani 1 sm va shkalaning bitta bo'lmasini 2 km deb oling. Ko'klam qishlog'idan soatiga 4 km tezlik bilan ketayotgan Asilbek a) 1 soat; b) 2 soat; d) 4 soatdan keyin shkalaning qaysi nuqtasida bo'lishini aniqlang.
92. Kilogramm bilan ifodalang:  
 a) 7 t 200 kg;      b) 4 t 565 kg;      d) 1 sr 86 kg;      e) 2 t 9 sr 12 kg.
93. Tonna va kilogrammlarda ifodalang:  
 a) 2547 kg;      b) 72 904 kg;      d) 35 831 kg;      e) 701 060 kg.
94. 8- rasmdagi ma'lumotlardan foydalanib diagramma tuzing.
95. 9- rasmda keltirilgan ustunli diagrammadan foydalanib, qadim zamonlarda yashagan dinozavrlarning massasini kilogrammda aniqlang.

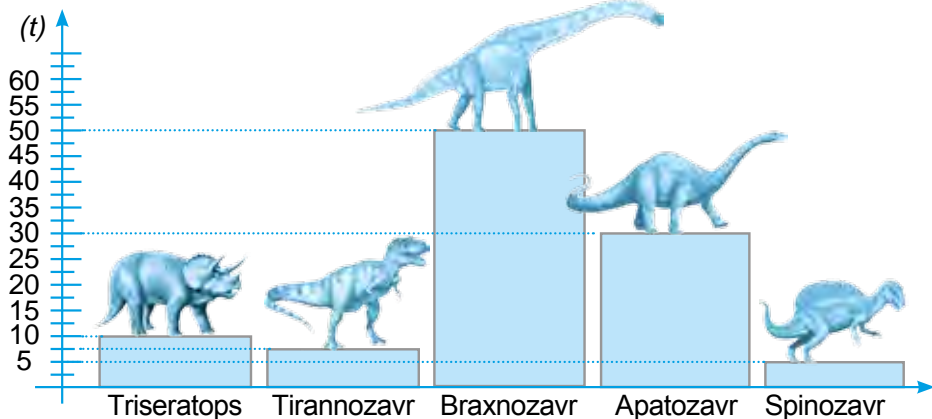

9- rasm

96. Toshkent teleminorasi dunyoda eng baland minoralardan biri hisoblanadi (10- rasm).

- a) Toshkent minorasi Berlin va Vena minoralaridan qancha baland?  
 b) Toronto, Kuala-Lumpur, Toshkent va Tokio shaharlaridagi minoralarning balandligini o'zaro taqqoslaydigan diagramma tuzing. Shkala tuzayotganda daftarning bitta katagi uzunligini 50 metr deb oling.

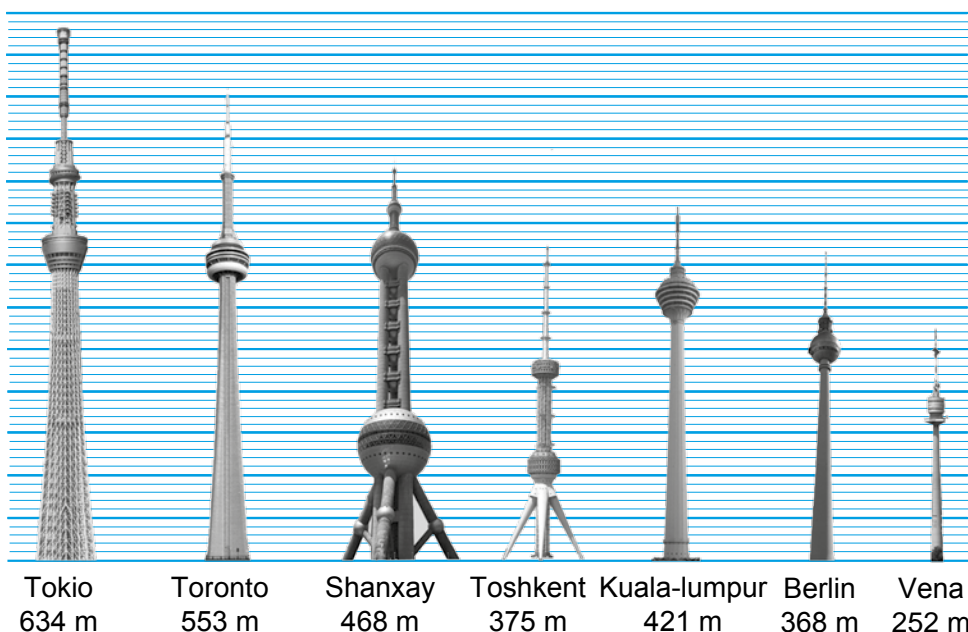

10- rasm

### Qiziqarli matematikaga oid masalalar



#### Bo'yingizni o'lchab boring! (Amaliy ish)

Uzunligi 2 m bo'lgan yopishqoq oq rangli tasma (dorixonada sotiladigan leykoplastir) oling. Tasmani bir uchi polga tegadigan qilib, eshik romiga tik holda yopishtiring. Unga bo'lmalari 1 sm dan bo'lgan shkala chizing. (Agar tasma topilmasa, shkalani bejirimgina qilib eshik romiga tik qilib chizish mumkin). Shkala yoniga tik turib, o'zingiz va boshqa oila a'zolaringiz bo'yini o'lchang. Agar har safar bo'yingizni shkalada belgilab, yoniga sanasini ham yozib borsangiz, yillar davomida qancha o'sayotganingizni bilib borasiz.

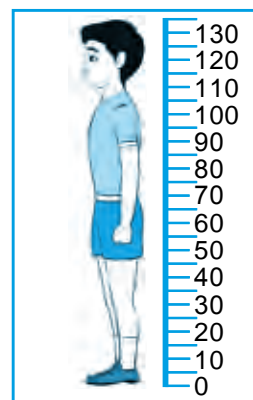

5-§.

**NATURAL SONLARNI TAQQOSLASH. KATTA YOKI KICHIK**

**5.1. Natural sonlarni sonlar nurida taqqoslash**

Ikkita turli *natural sonlarni taqqoslash* deganda, ularning qaysi biri katta yoki kichikligini aniqlashga aytiladi. Sonlar nuri natural sonlarni taqqoslash uchun juda qo'l keladi (1- rasm).



1- rasm

**!** Ikki natural sondan qaysi biri sonlar nurida chapda joylashgan bo'lsa, o'sha son kichik bo'ladi. Aksincha, qaysi biri o'ngda joylashgan bo'lsa, o'sha son katta bo'ladi.

Sonlarni taqqoslash natijasi tengsizlik ko'rinishida, katta (>) yoki kichik (<) belgilari yordamida yoziladi. 1- rasmda  $5 < 8$ , chunki sonlar nurida A(5) nuqta B(8) nuqtaga qaraganda chaproqda joylashgan.

8 soni 5 dan katta, lekin 10 sonidan kichik. Bu munosabat belgilar yordamida  $5 < 8 < 10$  *qo'shtengsizlik* ko'rinishida yoziladi.

**5.2. Turli xonali sonlarni taqqoslash**

Ko'p xonali sonlarni quyidagicha taqqoslash mumkin:

$$\begin{array}{c} \underline{5612} > \underline{963} \\ 4 \text{ xonali} & 3 \text{ xonali} \end{array}$$

Chunki, birinchi son to'rt xonali, ikkinchi son esa uch xonali ( $4 > 3$ ).

**!** Turli xonali sonlarni o'zaro taqqoslaganda qaysi birining xonalari ko'p bo'lsa, o'shanisi katta bo'ladi.

**5.3. Bir xil xonali sonlarni taqqoslash**

a)  $\underline{8}512 > \underline{3}925$ . Chunki har ikkala son to'rt xonali. Birinchi sonning minglar xonasidagi 8 raqami, ikkinchi sonning minglar xonasidagi 3 raqamidan katta ( $8 > 3$ ).

b)  $\underline{38}42 > \underline{36}18$ . Chunki har ikkala son to'rt xonali. Ularning minglar xonasidagi raqamlari bir xil 3 ga teng bo'lsada, birinchi sonning yuzlar xonasidagi 8 raqami ikkinchi sonning yuzlar xonasidagi 6 raqamidan katta ( $8 > 6$ ).

d)  $65 \underline{437} > 65 \underline{432}$ . Chunki har ikkala sonning birlar xonasidan boshqa barcha xonalaridagi raqamlari o'zaro teng. Lekin, birinchi sonning birlar xonasidagi 7 raqami, ikkinchi sonning birlar xonasidagi 2 raqamidan katta ( $7 > 2$ ).

Sonlardan birini ikkinchisining tagiga mos xona birliklaridagi raqamlari ostma-ost tushadigan qilib yozilsa, taqqoslash jarayoni osonlashadi. Haqiqatan ham,

$$\begin{array}{r} 8 \ 6 \ 5 \ 2 \ \underline{6}8 \\ 8 \ 6 \ 5 \ 2 \ \underline{3}1 \end{array}$$

$8=8, 6=6, 5=5, 2=2, 6 > 3$ . Demak,  $865268 > 865231$ .

Bir xil xonali sonlarni o'zaro taqqoslashda, ularning chap tomonidan boshlab bir xil nomdagi xonalarida turgan raqamlarini o'zaro taqqoslab chiqish kifoya.



Kesmalarni taqqoslash natijasi ham katta ( $>$ ) yoki kichik ( $<$ ) belgilari yordamida yoziladi.  $AB$  kesmaning  $CD$  kesmadan qisqaligi  $AB < CD$ ,  $MN$  kesmaning  $KL$  kesmadan uzun ekanligi esa  $MN > KL$  tarzda yoziladi.

### Savollarga javob bering!



- Ikki sonni taqqoslash deganda nima tushuniladi?
- Sonlar nurida ikkita natural son qanday taqqoslanadi?
- Besh xonali son kattami yoki yetti xonali son? Nega?
- Turli xonali sonlar qanday taqqoslanadi?
- Bir xil xonali sonlar qanday taqqoslanadi?

### Sinfda bajariladigan mashqlar



- 97.**  $A$  va  $B$  nuqtalarning qaysi biri sonlar nurida chapda yotadi?  
a)  $A$  (1) va  $B$  (8);      b)  $A$  (17) va  $B$  (38);      d)  $A$  (583) va  $B$  (539).
- 98.** a) 18 va 27; b) 2090 va 2095 sonlari orasidagi barcha natural sonlarni ayting.
- 99.** Qo'sh tengsizlik ko'rinishida ifodalang:  
a) 20 soni 10 sonidan katta, lekin 30 sonidan kichik;  
b) 44 soni 55 sonidan kichik, lekin 33 sonidan katta;  
d) 32 soni 43 sonidan kichik, 43 soni esa 54 sonidan kichik.
- 100.** Sonlar nurida a) 10 dan kichik; b) 12 dan katta, lekin 17 dan kichik bo'lgan barcha natural sonlarni ifodalang.
- 101.** Karim bir son o'yladi. Bu sonning oxirgi raqami 5 bilan tugaydi va bu son 300 dan katta, ammo 310 dan kichik. Bu qaysi son?
- 102.** Quyidagi ikkita sondan qaysi biri kattaligini aniqlang va javobingizni dastlab « $>$ » belgisi bilan, so'ng « $<$ » belgisi bilan ifodalang. Hosil bo'lgan tengsizlikni o'qing.  
a) 10 va 18;      b) 75 va 79;      d) 147 va 170;      e) 11 876 va 11 765;  
f) 2 660 008 va 2 665 001;      g) 6 877 500 600 va 6 876 999 999.
- 103.** Quyidagi sonlarning ba'zi raqamlari o'rniga yulduzchalar qo'yilgan. Ulardan qaysi biri katta ekanligini toping va tengsizlik ko'rinishida ifodalang:  
a)  $87^{***}$  va  $86^{***}$ ;      b)  $*5^{***}$  va  $*8^{**}$ .
- 104.** Quyidagi sonli tenglik va tengsizliklarning qaysilari to'g'ri?  
a)  $322 + 128 = 450$ ;      b)  $25 \cdot 22 = 5500$ ;      d)  $132 : 11 = 18 - 6$ ;  
e)  $58 \cdot 65 = 15625 : 25$ ;      f)  $24 \cdot 28 < 625$ ;      g)  $1320 : 40 > 35$ .
- 105.** 114 dan katta, lekin 133 sonidan kichik hamda oxirgi raqami 3 bilan tugaydigan sonni aniqlang.
- 106.** Sonlarni taqqoslang va yulduzcha o'rniga « $<$ » yoki « $>$ » belgisini qo'ying:  
a)  $456\,500 * 49\,900$ ;      b)  $36\,106 * 36\,099$ ;      d)  $77\,417 * 8432$ ;  
e)  $5\,000 * 49\,999$ ;      f)  $8\,720\,000 * 8\,720\,019$ ;      g)  $930\,000 * 1\,000\,001$ .



107. Rasmdagi kesmalar uzunligini chizg'ich yordamida o'lchang va ularni o'sib borish tartibida yozing.

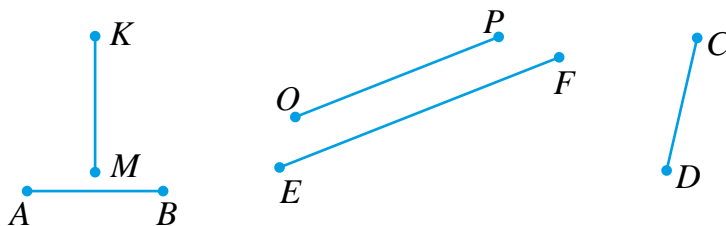

108. Rasmda keltirilgan ma'lumotlardan foydalanib,  $A$  va  $B$  nuqtalarning koordinatalarini toping.



109. Muzqaymoqning narxi 1500 so'm. Mahmud 5000 so'm puliga bu muzqaymoqdan a) ikkita; b) uchta; d) to'rtta sotib olishi mumkinmi?

110. Rasmga ko'ra masala tuzing va uni yeching.

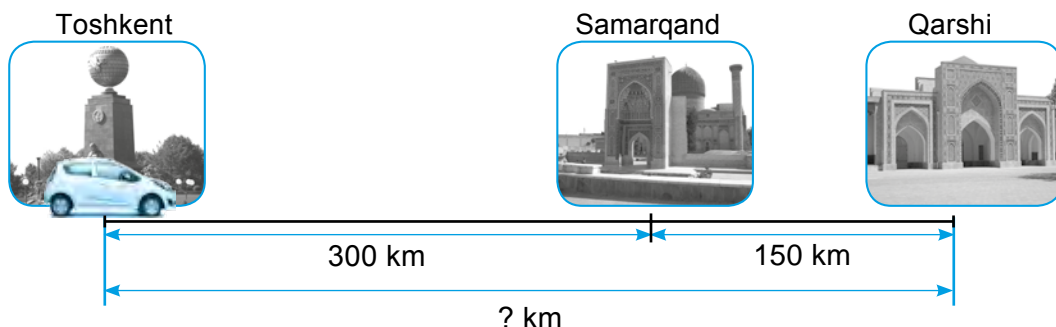

### Uyda bajariladigan mashqlar

111. Sonlar nurida  $A$  va  $B$  nuqtalarning qaysi biri chaproqda yotadi?

- a)  $A(5)$  yoki  $B(3)$ ;      b)  $A(47)$  yoki  $B(82)$ ;      d)  $A(557)$  yoki  $B(735)$ .

112. Qo'shtengsizlik ko'rinishida ifodalang:

- a) 10 soni 8 sonidan katta, lekin 23 sonidan kichik;  
 b) 75 soni 93 sonidan kichik, lekin 57 sonidan katta;  
 d) 42 soni 65 sonidan kichik, 65 soni esa 87 sonidan kichik.

113. a) 7 dan kichik; b) 15 dan katta, lekin 22 dan kichik bo'lgan barcha sonlarni sonlar nurida tasvirlang.

114. Quyidagi sonlarni taqqoslang, hamda yulduzcha o'rniga «<» yoki «>» belgisini qo'ying:

- a)  $600\ 080 * 609\ 900$ ;      b)  $43\ 006 * 43\ 007$ ;      d)  $91\ 453 * 91\ 811$ ;  
 e)  $80\ 000 * 79\ 999$ ;      f)  $1\ 039\ 000 * 1\ 034\ 099$ ;      g)  $5\ 000\ 009 * 5\ 000\ 010$ .

115. Asqar Samarqanddan Toshkentga tezligi 100 km/soat bo'lgan yengil avtomashinada 3 soatda yetib keldi. Toshkentdan Samarqandga tezligi 75 km/soat bo'lgan avtobusda qaytdi. Asqar necha soatda Toshkentdan Samarqandga yetib kelgan?
116. Alisher 10 km/soat tezlik bilan 6 soat yo'l yurdi. Sheralining tezligi Alisher-nikidan 2 km/soat katta. Sherali bu yo'lni qancha vaqtda bosib o'tadi?
117. Amallarni bajaring:  
 a)  $(1269 + 1261) : 115$ ;                      b)  $(813 - 186) : 3 + 10\,000$ ;  
 d)  $401\,000 : (623 + 377)$ ;                      e)  $47234 : 113 + 22 \cdot 13$ .
118. Rasmda keltirilgan ma'lumotlardan foydalanib,  $C$  va  $D$  nuqtalarning koordinatalarini toping.



### Matematika tarixiga oid lavhalar



Natural sonlarni ifodalash uchun turli belgilardan foydalanilgan. Bundan 5000 yil avval Qadimgi misrliklar birni – «I», o'nni – «C», yuzni esa – «∩» belgilar bilan ifodalashgan.

Bu belgilashda 234 soni - ∩∩ C C C IIII tarzda yoziladi.

2500 yil oldin esa natural sonlar rim raqamlari yordamida yozilgan. Raqamlar sifatida bosh lotin harflaridan foydalanilgan va ularning qiymatlari quyidagicha deb qabul qilingan:

I – 1, V – 5, X – 10, L – 50, C – 100, D – 500, M – 1000.

Yozuvda qatnashgan rim raqamlari qiymatlarining yig'indisi natural sonni aniqlagan. Bu belgilar yordamida 27 soni XXVII tarzda yozilgan, chunki

$$10 + 10 + 5 + 1 + 1 = 27.$$

Shuningdek, yozuvda qiymat jihatidan kichik bo'lgan raqam kattasidan oldinda tursa, kichigining qiymati kattasining qiymatidan ayirilgan:

$$IV = 4 (5 - 1 = 4); \quad IX = 9 (10 - 1 = 9); \quad XC = 90 (100 - 10 = 90).$$

Rim raqamlari bilan yozilgan MCMLXXVI soni 1976 ni anglatadi. Chunki,

$$1000 + (1000 - 100) + 50 + 10 + 10 + 5 + 1 = 1976.$$

Hozirgi kunda rim raqamlari - tartib raqamlari sifatida kitob boblarini va asrlarni ifodalashda ishlatib kelinmoqda: XX asr, VII bob va hokazo. Ularni ba'zi soat shkalalarida ham uchratish mumkin.

### Qiziqarli matematikaga oid masalalar



Hoshimjon sinfdoshlariga rim raqamlaridan tuzilgan bir nechta tengliklarni namoyish qilayotib, bu tengliklarning har birida bittadan tayoqchani o'z joyiga qo'ymanini sezib qoldi. Marhamat, siz Hoshimjonning bu xatolarini tuzatib ko'ring-chi.

a)  $VI + I = V$

b)  $X + III = XI$

d)  $IX - I = X$

e)  $X = VII - III$

**6.1. Amaliy mashg'ulot: Jadvallar va ma'lumotlar bilan ishlash**

Siz jadvallar bilan allaqachon tanishsiz. Kundalik daftaringiz, sinf jurnali, navbatchilar ro'yxati – jadvallarga misol bo'la oladi. Jadval tuzishdan maqsad biror mavzuga oid ma'lumotlarni tartibga solishdan va ulardan foydalanishni osonlashtirishdan iborat.

*1- misol.* O'quvchi yangi o'quv yili oldidan do'kondan narxi 7000 so'm bo'lgan bitta sumka, narxi 400 so'm bo'lgan 20 ta daftar, har biri 200 so'm bo'lgan 3 ta ruchka, narxi 1200 so'm bo'lgan 2 ta rangli qalamlar to'plami sotib oldi.

Bu ma'lumotlar asosida jadval tuzing. Jadvalda har bir o'quv qurolining narxi, miqdori, qiymati va jami o'quv qurollari uchun necha so'm sarflangani aks etsin.

*Yechish:* Jadvalning ustunlarini nomlab chiqamiz. Birinchi ustunga tartib raqami, ikkinchi ustunga «O'quv qurollari nomlari» va keyingi ustunlarga «Bir donasining narxi», «Miqdori» va «Qiymati» deb yozib qo'yamiz. Shundan so'ng, berilgan ma'lumotlardan foydalanib jadvalni to'ldiramiz. Oxirgi qatorga esa, «Jami to'langan pul», degan so'zlarni yozib qo'yamiz.

№	O'quv qurollari nomlari	Bir donasining narxi	Miqdori	Qiymati
1.	Sumka	7 000	1	
2.	Daftar	400	20	
3.	Ruchka	200	3	
4.	Rangli qalamlar	1 200	2	
	Jami to'langan pul	–	–	

Jadvalning oxirgi ustunini to'ldirish uchun, har bir qatordagi o'quv qurollarining bir donasi narxini, ularning miqdoriga ko'paytirib, shu qatorning oxirgi ustuniga yozamiz. Bu bilan har bir o'quv quroliga jami necha so'm to'langanligini topamiz. So'ng esa, oxirgi ustundagi hamma sonlarni qo'shib, yig'indini oxirgi ustunning oxirgi qator bilan kesishish joyiga yozamiz. Bu son o'quv qurollari uchun to'langan jami pulning miqdorini bildiradi.

№	O'quv qurollari nomlari	Bir donasining narxi	Miqdori	Qiymati
1.	Sumka	7000	1	7 000
2.	Daftar	400	20	8 000
3.	Ruchka	200	3	600
4.	Rangli qalamlar	1200	2	2 400
	Jami to'langan pul	–	–	18 000



119. Quyidagi jadvalda berilgan ma'lumotlardan foydalanib, bir hafta davomida supermarket bo'limlarining har biriga kelib tushgan tovarlarning qiymatini hisoblang. Xuddi shu hisob-kitobni butun supermarket bo'yicha ham bajaring.

Hafta kunlari	Bo'limlar			Jami supermarket bo'yicha
	Kiyim-kechak	Poyabzal	Gazmollar	
Dushanba	6 500 000	4 500 000	3 300 000	
Seshanba	8 600 000	5 110 000	4 400 000	
Chorshanba	13 200 000	8 020 000	5 100 000	
Payshanba	8 700 000	3 600 000	7 100 000	
Juma	10 860 000	9 870 000	6 520 000	
Shanba	9 800 000	5 640 000	3 820 000	
Jami:				

120. Jadvalni to'ldiring:

1- qo'shiluvchi	450		11239
2- qo'shiluvchi	409	13428	
Yig'indi		234581	987111

121. Jadvalda mebel fabrikasining yanvar, fevral, mart oylarida ishlab chiqargan mahsulotlarining qiymatlari (so'mda) ko'rsatilgan. Jadvalning bo'sh kataklarini to'ldiring.

Mahsulotlar	Yanvar	Fevral	Mart	Jami
Stullar	1 567 800		1 594 900	4 641 800
Stollar	2 910 500	2 801 600		
Javonlar	145 280		1 471 000	
<b>Jami:</b>		5 655 900		17 652 000

122. Quyidagi jadvalda uchta ishchining birinchi yarim yildagi oylik maoshlari (so'mda) keltirilgan. Har bir oy bo'yicha qaysi ishchi ko'proq maosh olgan? Yarim yilda-chi? Uchta ishchi birgalikda qaysi oyda eng ko'p maosh olgan?

	yanvar	fevral	mart	aprel	may	iyun	Jami:
1-ishchi	468 000	489 300	439 100	301 800	522 300	467 500	
2-ishchi	352 800	432 100	442 300	412 300	534 500	448 100	
3-ishchi	293 600	395 700	411 800	399 100	445 000	470 000	
Jami:							

123. Sonlarni o'qing.

- a) 112 657 209 045;    b) 62 000 77;  
 d) 45 670 888 009;    e) 621 600 670 099.

124.  $AB$  kesmani  $C$  nuqta  $AC$  va  $CB$  qismlarga ajratadi. Agar  $AC$  kesma uzunligi 79 sm bo'lib, u  $CB$  kesmadan 45 sm uzun bo'lsa,  $AB$  kesma uzunligini toping.
125.  $AB$  kesmani  $C$  va  $D$  nuqtalar ketma-ket kelgan  $AC$ ,  $CD$  va  $DB$  qismlarga ajratadi. Agar  $AC$  kesma uzunligi 65 dm bo'lib, u  $CD$  kesmadan 30 dm qisqa,  $DB$  kesma  $CD$  dan 42 dm uzun bo'lsa,  $AB$  kesma uzunligini toping.
126. Quyidagi shkalalarning bitta bo'lmasi qiymatini aniqlang.

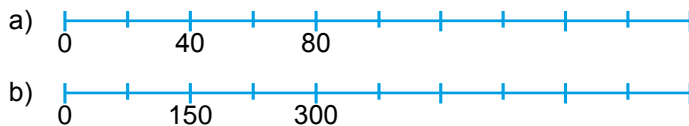

127. Grammda ifodalang:

- a) 5 kg 998 g;                      b) 7 kg 454 g;                      d) 8 sr 12 kg 881 g.

128. Tonna va kilogrammlarda ifodalang:

- a) 44 356 kg;                      b) 70096 kg;                      d) 1000032 kg;                      e) 860221 kg.

129. Santimetrda ifodalang:

- a) 21 dm 9 sm                      b) 12 dm 5 sm;                      d) 34 dm 2 sm;                      e) 102 dm 7 sm.

130. Santimetr va millimetrlarda ifodalang:

- a) 540 mm;                      b) 887 mm;                      d) 324 mm;                      e) 1297 mm.

131. Ko'pburchaklarni daftaringizga chizing va belgilang. Chizg'ich yordamida ularning tomonlari uzunliklarini millimetrda o'lchang va perimetrini toping.

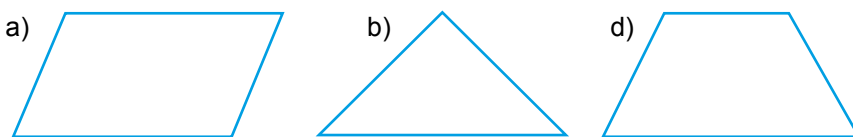

132.  $AB$  kesma uzunligi 112 sm ga teng. Noma'lum kesma uzunligini toping.

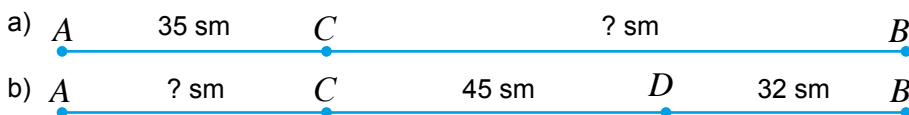

133. Quyidagi sonlarni taqqoslang, hamda yulduzcha o'rniga «<» yoki «>» belgisini qo'ying.

- a) 556 500 \* 59 900;                      e) 6 590 000 \* 6 590 019;
- b) 41 106 \* 41 099;                      f) 2 990 000 \* 21 000 001;
- d) 8 000 \* 79 999;                      g) 81 320 000 \* 81 316 999.

134. Rasmda keltirilgan ma'lumotlardan foydalanib, sonlar nurida  $A$  va  $B$  nuqtalarning koordinatasini toping.

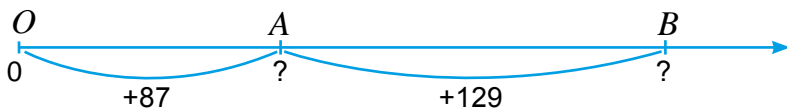

### Bilimingizni sinab ko'ring!



Bu bob materiallarini o'rganib chiqib, quyidagi masalalarni yecha olishingiz shart! Nazorat ishi oldidan o'zingizni sinab ko'ring!

**Test.** To'g'ri javobni aniqlang.

- Ikki million besh yuz olti ming uch yuz yetmish yetti soni necha xonali?  
 A. Olti;                      B. Besh;                      D. Yetti;                      E. Sakkiz;
- Har qanday ikki nuqtadan nechta to'g'ri chiziq o'tkazish mumkin?  
 A. Ikkita;                      B. Bitta;                      D. Uchta;                      E. Istalgancha;
- Sonlar nurida 23, 12, 19 va 35 sonlaridan qaysi biri eng chapda joylashgan?  
 A. 23;                      B. 12;                      D. 19;                      E. 35;

### 1- nazorat ishi namunasi

- Sonlarni taqqoslang va javobni «<» yoki «>» belgilari yordamida yozing:  
 a) 2 657 209 va 2 654 879;                      b) 96 785 va 354 211.
- $MN$  to'g'ri chiziq va  $CD$  nurni shunday chizingki, ular kesishmasin.
- Raqamlar bilan yozing: uch yuz besh million sakkiz ming olti.
- a) sonlar nurida  $A, F, K, O$  nuqtalarning koordinatalarini yozing:



- b) daftar katagi enini birlik kesma sifatida olib, sonlar nurida  $B (8), D (11), P (1), R (16)$  nuqtalarni belgilang.
- 9987 dan katta va 6 raqami bilan tugaydigan to'rt xonali sonni yozing.

**II BOB. NATURAL SONLARNI QO‘SHISH VA AYIRISH**

**7-§. NATURAL SONLARNI QO‘SHISH VA UNING XOSSALARI**

**7.1. Natural sonlarni qo‘shish**

Maydonchada 4 ta poyga mashinasi turgan edi. Ularga birin-ketin yana 3 ta mashina kelib qo‘shildi (1- rasm). Maydonchada jami nechta poyga mashinasi bo‘ldi?

Bu masalani yechish uchun avtomobillarni sanab chiqish kifoya:

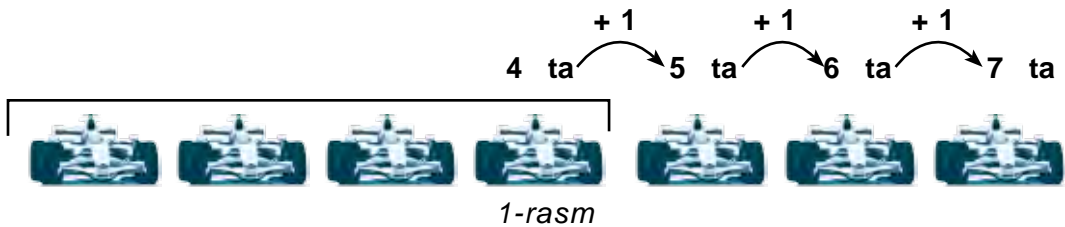

Demak, 4 ga 3 ni qo‘shish - 4 soniga 3 marta 1 ni qo‘shish degani:

$$4 + 3 = 4 + 1 + 1 + 1 = 5 + 1 + 1 = 6 + 1 = 7.$$

Bu qisqacha  $4 + 3 = 7$  tarzida yoziladi.

Bir-biriga qo‘shiluvchi sonlar – *qo‘shiluvchilar*, qo‘shish natijasi esa *yig‘indi* deb ataladi. Xususan,  $4 + 3$  ham *yig‘indi* deb yuritiladi.

$$\begin{array}{ccccccc} & & \text{yig‘indi} & & & & \text{yig‘indi} \\ & \overbrace{\hspace{1.5cm}} & & & & & \overbrace{\hspace{1.5cm}} \\ 18 & + & 37 & = & 55 \\ \text{1- qo‘shiluvchi} & & \text{2- qo‘shiluvchi} & & & & \end{array}$$

Sonlarni qo‘shishni sonlar nurida ham tasvirlash mumkin (2- rasm).  $A(4)$  nuqtadan o‘ng tomonga qarab 3 ta birlik kesmani sanaymiz va  $B(7)$  nuqtani topamiz.

Demak,  $4 + 3 = 7$ .

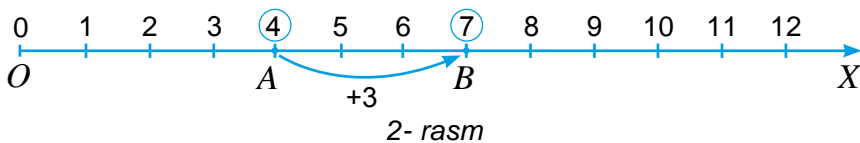

## 7.2. Natural sonlarni qo'shishning xossalari

Qo'shish amalining bir nechta xossalarini keltiraylik:

Qo'shiluvchilarning o'rnini almashtirgan bilan yig'indi o'zgarmaydi.



*1-misol:*  $6 + 3 = 9$  va  $3 + 6 = 9$  bo'lgani uchun:  $6 + 3 = 3 + 6$ .

Qo'shishning bu xossasi *qo'shishning o'rin almashtirish qonuni* deb ataladi.

Bir nechta qo'shiluvchilar yig'indisi bu qo'shiluvchilarning qaysi tartibda qo'shilishiga bog'liq emas.



*2-misol:* 21, 14 va 45 sonlari yig'indisini hisoblang.

Yig'indini ikki xil usul bilan hisoblash mumkin:

1) oldin  $21 + 14$  sonlari yig'indisini topib, unga 45 sonini qo'shamiz:  
 $(21 + 14) + 45 = 35 + 45 = 80$ ;

2) oldin 14 va 45 sonlari yig'indisini topib, unga 21 ni qo'shamiz:  
 $21 + (14 + 45) = 21 + 59 = 80$ .

Ko'rib turganingizdek, natija bir xil, ya'ni bu uchta sonlar yig'indisi, ularni qaysi tartibda qo'shilishiga bog'liq emas.

Qo'shishning bu xossasi *qo'shishning guruhlash qonuni* deb ataladi.

Bundan bir nechta sonlarni qo'shayotganda, yig'indida ularning o'rinini istalgancha almashtirib yozish yoki ularni qavslar yordamida istalgan tartibda guruhlash mumkinligi kelib chiqadi:

$$54 + 67 + 31 + 79 = 67 + 79 + 54 + 31,$$

$$54 + 67 + 31 + 79 = (54 + 67) + (31 + 79).$$

Shuningdek, odatda  $(4 + 7) + 3$  o'rniga  $4 + 7 + 3$  yoziladi. Agar yozuvda qavslar qatnashmagan bo'lsa, qo'shish chapdan o'ngga qarab birin-ketin bajariladi.

Qo'shishning guruhlash qonunidan sonlar yig'indisini qulay usul bilan hisoblashda ham foydalanish mumkin.

*3-misol:* Yig'indini qulay usulda hisoblang:  $54 + 39 + 78 + 46 + 61$ .

Qo'shishning guruhlash qonunidan foydalanib, sonlarni qo'shishga qulay qilib quyidagicha guruhlaymiz va yig'indini topamiz:

$$54 + 39 + 78 + 46 + 61 = (54 + 46) + (39 + 61) + 78 = 100 + 100 + 78 = 278.$$

Ikki qo'shiluvchidan biri nol bo'lsa, yig'indi ikkinchi qo'shiluvchiga teng bo'ladi.



*4-misol:*  $6 + 0 = 0 + 6 = 6$ .

Har qanday natural sonni uning xona qo'shiluvchilari yig'indisi ko'rinishida tasvirlash mumkin.



*5-misol:* 78135 sonini quyidagi qo'shiluvchilar yig'indisi ko'rinishida yozish mumkin:

$$78\ 135 = 7\ 0\ 0\ 0\ 0 + 8\ 0\ 0\ 0 + 1\ 0\ 0 + 3\ 0 + 5$$

yoki

$$78\ 135 = 7 \cdot 10\ 000 + 8 \cdot 1000 + 1 \cdot 100 + 3 \cdot 10 + 5 \cdot 1$$

Bu xossadan ko'p xonali sonlarni ustun shaklida qo'shishda foydalaniladi.

**6-misol:** 345 va 621 sonlari yig'indisini topaylik.

Oldin har bir sonni uning xona qo'shiluvchilari yig'indisi ko'rinishida tasvirlaymiz, so'ng mos xona birliklarini guruhlab qo'shib chiqamiz:

$$\begin{array}{r} + 345 \\ 621 \\ \hline 966 \end{array}$$

$$345 + 621 = (300 + 40 + 5) + (600 + 20 + 1) = (300 + 600) + (40 + 20) + (5 + 1) = 966.$$

Sonlarni «ustun shaklida qo'shish» usuli yuqoridagi hisoblashlarga asoslangan.



### Savollarga javob bering!

- 5 soniga 4 sonini qo'shish deganda nimani tushunasiz?
- Qo'shish amalining natijasi nima deb ataladi?
- Qo'shishning o'rin almashtirish qonunini sonlar nurida tushuntirib bering.
- Songa nol qo'shilsa, yig'indi nimaga teng bo'ladi?
- Natural son xona qo'shiluvchilari yig'indisi ko'rinishida qanday tasvirlanadi?



### Sinfda bajariladigan mashqlar

**135.** Sonlar nurida  $A(8)$  nuqtani va undan 7 birlik o'ngda joylashgan  $B$  nuqtani belgilang. Sonlar nurida  $B$  nuqtaning koordinatasi nechga teng bo'ladi?

**136.**  $77 + 23$  yig'indini hisoblang. 100 sonini hosil qilish uchun 77 ga nechta birni qo'shish kerak?

**137.** Hisoblang:

- a)  $7\ 012 + 50\ 367$ ;      b)  $70\ 046 + 48\ 992$ ;      d)  $27\ 330 + 1\ 360$ ;  
 e)  $3\ 485 + 2\ 7341$ ;      f)  $50\ 022 + 64\ 502$ ;      g)  $977\ 200 + 127\ 033$ .

**138.** Sonlar yig'indisini toping:

- a) 522, 44, 8 904;      b) 709, 234, 2 064;  
 d) 5 089, 444, 2 100, 209;      e) 40 511, 38 872, 294, 77 062;

**139.** Quyidagi jadvalda mebel fabrikasining daromadi (so'mda) ko'rsatilgan. Jadvalning bo'sh kataklarini to'ldiring. Agar hamma amallarni to'g'ri bajarsangiz, oxirgi qator va oxirgi ustundagi sonlar yig'indisi bir-biriga teng chiqishi kerak.

Mahsulot	Yanvar	Fevral	Mart	Jami:
Stol	1 576 400	1 465 400	1 798 500	
Stul	2 951 500	2 871 400	2 764 800	
Shkaf	1 479 500	1 332 100	1 574 800	
Jami:				

**140.**  $A$  shahardan  $B$  shaharga qanday yo'llar bilan borish mumkinligini aniqlang. Har bir yo'lining uzunligini toping va ular orasidan eng qisqa yo'lni aniqlang.

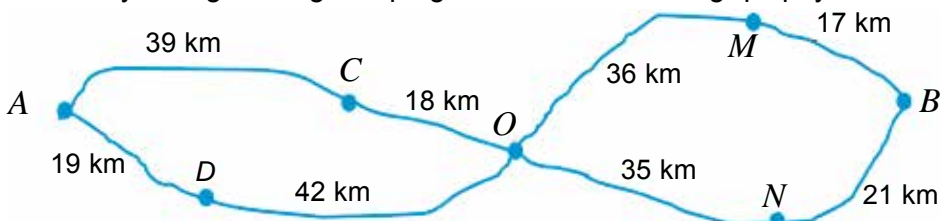

**Namuna:** Yo'llardan biri ( $A-C-O-M-B$ ) uzunligi:  $39 + 18 + 36 + 17 = 110$  (km).

- 141.** Aziz bozordan 2 kg kartoshka, 3 kg lavlagi, 5 kg sabzi, 4 kg olma, 5 kg karam, 2 kg nok va 3 kg olxo'ri xarid qildi. U necha kg meva va qancha sabzavot xarid qilgan?

**142.** Yig'indini toping:

- a)  $4 \cdot 10000 + 2 \cdot 1000 + 1 \cdot 100 + 9 \cdot 10 + 3 \cdot 1$ ;  
 b)  $4\ 000\ 000 + 200\ 000 + 80\ 000 + 1\ 000 + 400 + 80 + 7$ ;  
 d)  $700\ 000 + 30\ 000 + 200 + 40 + 3$ ;

*Namuna:* a)  $4 \cdot 10\ 000 + 2 \cdot 1000 + 1 \cdot 100 + 9 \cdot 10 + 3 \cdot 1$  ifoda sonning xona qo'shiluvchilari yig'indisidan iborat. Shuning uchun berilgan yig'indi 42 193 ga teng.

- 143.** Fermer xo'jaligida birinchi kuni 125 t, ikkinchi kuni birinchi kundagidan 42 t ko'p kartoshka terib olindi. Uchinchi kun esa ikkinchi kundagidan 28 t ko'p kartoshka terib olindi. Uch kunda jami necha tonna kartoshka terib olindi?

- 144.** Avtomobil yo'l hisoblagichi qanday sonni ko'rsatadi?

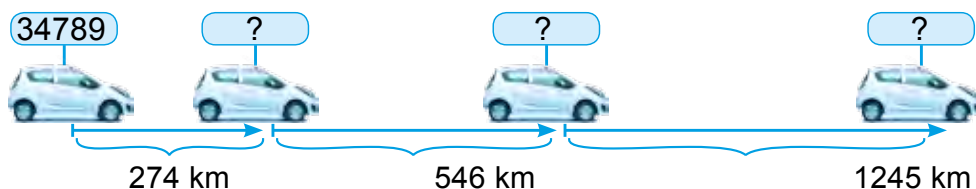

- 145.** Qo'shiluvchilarni bir-birini «qulay» songa to'ldiradigan guruhlarga ajratib, yig'indini hisoblang.

- a)  $3 + 3 + 7 + 8 + 2 + 7 + 9 + 1$ ;      b)  $15 + 24 + 23 + 15 + 26 + 37 + 78 + 12$ ;

*Namuna:*  $4 + 8 + 6 + 2 = (4 + 6) + (8 + 2) = 10 + 10 = 20$ .

- 146.** Qo'shishning guruhlash qonunini qo'llab yig'indini hisoblang:

- a)  $(6347 + 3747) + 6253$ ;      b)  $9999 + (4701 + 20\ 200)$ ;  
 d)  $(44\ 888 + 69\ 999) + 10\ 001$ ;      e)  $18\ 856 + (1544 + 3322)$ .

*Namuna:*

a)  $(6347 + 3747) + 6253 = 6347 + (3747 + 6253) = 6347 + 10\ 000 = 16347$ .

- 147.** Yig'indini qulay usulda hisoblang:

- a)  $325 + 484 + 675$ ;      e)  $448 + 323 + 52 + 77$ ;  
 b)  $321 + 337 + 363$ ;      f)  $123 + 978 + 277 + 22$ ;  
 d)  $234 + 456 + 166$ ;      g)  $511 + 245 + 855 + 89$ .

*Namuna:* a)  $325 + 484 + 675 = (325 + 675) + 484 = 1000 + 484 = 1484$ .

- 148.**  $ABC$  uchburchakning  $AB$  tomoni  $BC$  tomonidan 4 sm qisqa va  $AC$  tomonidan esa 3 sm uzun. Agar  $AC = 17$  sm ekanligi ma'lum bo'lsa,  $ABC$  uchburchakning perimetrini hisoblang.

- 149.** Yig'indini qulay usulda hisoblang:

- a)  $11 + 12 + 13 + 14 + 15 + 16 + 17 + 18 + 19 + 20$ ;  
 b)  $23 + 25 + 27 + 29 + 31 + 33 + 35 + 37$ ;  
 d)  $5 + 10 + 15 + 20 + \dots + 100$ ;  
 e)  $94 + 84 + 74 + \dots + 24 + 14 + 4$ .

**Namuna:** a)  $11 + 12 + 13 + 14 + 15 + 16 + 17 + 18 + 19 + 20 =$

$$= (11 + 20) + (12 + 19) + (13 + 18) + (14 + 17) + (15 + 16) =$$

$$= 31 + 31 + 31 + 31 + 31 = 31 \cdot 5 = 155.$$



### Uyda bajariladigan mashqlar

**150.** Sonlar nurida  $M(6)$  nuqtani va undan 8 birlik o'ngda joylashgan  $N$  nuqtani belgilang. Sonlar nurida  $N$  nuqtaning koordinatasi nechaga teng bo'ladi?

**151.** Hisoblang:

a)  $2570 + 47\,534;$

b)  $67\,423 + 24\,137;$

d)  $26507 + 1760;$

e)  $8534 + 34\,271;$

f)  $51\,700 + 9760;$

g)  $39\,523 + 6670.$

**152.** Sonlar yig'indisini toping:

a)  $102, 56, 1324;$

b)  $650, 17, 2333;$

d)  $1003, 467, 85;$

e)  $449, 257, 134, 112;$

f)  $435, 6027, 239, 2123;$

g)  $260, 35070, 6306, 32.$

**153.** Rasmda tasvirlangan kalitning uzunligini aniqlang.



**154.** Asilbek va Shohruh pomidor terishdi. Asilbek  $12\text{ kg } 750\text{ g}$ , Shohruh esa Asilbekdan  $8\text{ kg } 500\text{ g}$  ko'proq pomidor terdi. Ular jami qancha pomidor terishdi?

**155.** Yig'indini toping:

a)  $7 \cdot 10000 + 4 \cdot 1000 + 3 \cdot 100 + 4 \cdot 10 + 7 \cdot 1;$

b)  $1\,000\,000 + 500\,000 + 60\,000 + 3\,000 + 200 + 90 + 5;$

d)  $600\,000 + 6\,000 + 700 + 30 + 1.$

**156.** Fermer xo'jaligida birinchi kuni  $342\text{ t}$ , ikkinchi kuni birinchi kundagidan  $22\text{ t}$  ko'p piyoz terib olindi. Uchinchi kun esa ikkinchi kundagidan  $18\text{ t}$  ko'p piyoz terib olindi. Uch kunda jami necha tonna piyoz terib olindi?



**157.** Qo'shiluvchilarni bir-birini «qulay» songa to'ldiradigan guruhlarga ajratib, yig'indini hisoblang:

a)  $16 + 21 + 13 + 24 + 19 + 27;$

b)  $347 + 118 + 249 + 53 + 162 + 81.$

**158.** Qo'shishning guruhlash qonunini qo'llab yig'indini hisoblang:

a)  $(374 + 712) + 626;$

b)  $999 + (901 + 2200);$

d)  $(3355 + 7777) + 2223.$

**159.** Yig'indini qulay usulda hisoblang:

a)  $51 + 52 + 53 + 54 + 55 + 56 + 57 + 58;$

b)  $122 + 124 + 126 + 128 + 130 + 132 + 134 + 136 + 138.$



8-§.

**NATURAL SONLARNI AYIRISH VA UNING XOSSALARI**

**8.1. Natural sonlarni ayirish**

*1- misol.* Shahzoda kitobning 48 betini o'qiganidan keyin kitobning yana 24 beti o'qilmay qoldi. Kitob necha betdan iborat?

*Yechish.* Masala qo'shish amali yordamida yechiladi:  $48 + 24 = 72$ .

*Javob:* Kitob 72 betdan iborat.

Endi boshqa misolni qaraylik.

*2- misol.* Kitob 72 betdan iborat. Shahzoda kitobning 48 betini o'qidi. Kitobning yana necha beti o'qilmay qoldi?

*Yechish.* Shunday sonni topishimiz kerakki, unga 48 ni qo'shganda, 72 hosil bo'lsin. Bunday son  $-24$ , chunki  $48 + 24 = 72$ .

*Javob:* Kitobning yana 24 beti o'qilmay qolgan.

Bu holda 24 soni 72 va 48 *sonlarining ayirmasi* deb ataladi va  $72 - 48$  shaklida ifodalanadi. Demak,  $72 - 48 = 24$ .

Yig'indi va bitta qo'shiluvchiga ko'ra ikkinchi qo'shiluvchini topishga *ayirish amali* deyiladi. Ayiriladigan son  $-$  *ayiriluvchi*, ayiriluvchi ayriladigan son  $-$  *kamayuvchi* va ayirish amali natijasi *ayirma* deb ataladi. Xususan,  $72 - 48$  ham ayirma deb yuritiladi.

$$\begin{array}{ccccccc} & & \text{ayirma} & & & & \text{ayirma} \\ & & \text{-----} & & & & \text{-----} \\ 72 & - & 48 & = & 24 \\ \text{kamayuvchi} & & \text{ayiriluvchi} & & & & \end{array}$$

Natural sonlarni ayirishda kamayuvchi ayiriluvchidan kichik bo'lishi mumkin emas. 

Ikki sonning ayirmasi  $-$  birinchi son ikkinchisidan *qanchaga ko'p* ekanligini yoki ikkinchi son birinchisidan *qanchaga kam* ekanligini anglatadi.

Natural sonlarni ayirishni sonlar nurida tasvirlash mumkin. Masalan, 8 sonidan 5 sonini ayirish talab qilinsin. Sonlar nurida  $A(8)$  nuqtani belgilaymiz (1- rasm).

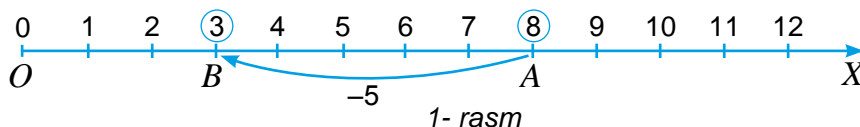

Undan chapga qarab 5 birlik kesma sanaymiz va  $B(3)$  nuqtani topamiz.

Demak,  $8 - 5 = 3$ .

Sonlar nurida  $A$  va  $B$  nuqtalar orasida 5 ta birlik kesma joylashgan. Demak,  $A$  va  $B$  *nuqtalar orasidagi masofa* 5 ga teng bo'ladi. Bu  $AB = 5$  tarzida yoziladi.

Agar ikki nuqtaning koordinatalari berilgan bo'lsa, unda ular orasidagi masofani topish uchun nuqtalar koordinatalarining kattasidan kichigi ayiriladi, ya'ni

$$AB = 8 - 3 = 5.$$

## 8.2. Natural sonlarni ayirishning xossalari

### 1. Sondan yig'indini ayirish xossasi

1-misol. Hisoblang:  $314 - (114 + 77)$ .

1-usul:  $314 - (114 + 77) = 314 - 191 = 123$ .

Bu amallarni quyidagi «sondan yig'indini ayirish» xossasidan foydalanib ham bajarish mumkin.



Sondan yig'indini ayirish uchun oldin kamayuvchidan biror qo'shiluvchini ayirish, so'ng ayirmadan ikkinchi qo'shiluvchini ayirish kifoya.

2-usul: a)  $314 - (114 + 77) = (314 - 114) - 77 = 200 - 77 = 123$ .

b)  $314 - (114 + 77) = (314 - 77) - 114 = 237 - 114 = 123$ .

### 2. Yig'indidan sonni ayirish xossasi

2-misol. Hisoblang:  $(374 + 231) - 174$ .

1-usul:  $(374 + 231) - 174 = 605 - 174 = 431$ .

Bu amallarni quyidagi «yig'indidan sonni ayirish» xossasidan foydalanib ham bajarish mumkin.



Yig'indidan sonni ayirish uchun sonni qo'shiluvchilardan birortasidan ayirib, hosil bo'lgan ayirmaga ikkinchi qo'shiluvchini qo'shib qo'yish kifoya.

2-usul:  $(374 + 231) - 174 = (374 - 174) + 231 = 431$ .

Albatta, bu xossani qo'llash uchun ayriladigan son qo'shiluvchilarning birortasidan katta bo'lmasligi kerak.

### 3. Ayirishda nolning xossalari

3-misol. Ma'lumki,  $7 + 0 = 7$ .

Unda, ayirish amali ma'nosiga ko'ra,  $7 - 0 = 7$  va  $7 - 7 = 0$  bo'ladi.

Demak, quyidagi ayirishda nolning xossalari o'rinli bo'ladi.



Sondan nol ayirilganda ayirma o'sha sonning o'zi bo'ladi. Kamayuvchi va ayiriluvchi o'zaro teng bo'lsa, ayirma nolga teng bo'ladi.



### Savollarga javob bering!

1. Ikkita sonning ayirmasi deb nimaga aytiladi?
2. Kamayuvchi ayiriluvchidan kichik bo'lishi mumkinmi?
3. Ikki sonning ayirmasi nimani anglatadi?
4. Sondan yig'indini ayirish qoidasini sonlar nurida tushuntiring.



### Sinfda bajariladigan mashqlar

160. Sonlar nurida  $M(15)$  nuqtani belgilang va undan 7 birlik chapda joylashgan  $T$  nuqtani belgilang.  $T$  nuqtaning sonlar nuridagi koordinatasini toping.

161. Ayirishni amalga oshirib bo'ladimi? Nega?

- a)  $342 - 424$ ; b)  $654 - 444$ ; d)  $399 - 0$ ; e)  $0 - 42$ ; f)  $23\ 451 - 23\ 456$ .

*Namuna:* Ayirishni amalga oshirish uchun kamayuvchi ayiriluvchidan kichik bo'lmasligi kerak. a) holda  $324 < 424$ . Demak, ayirishni amalga oshirib bo'lmaydi.

162. Qo'shish amali yordamida quyidagi tengliklarni tekshiring:

- a)  $2158 - 599 = 1559$ ; b)  $2601 - 765 = 1836$ ; d)  $10\ 032 - 2255 = 7777$ ;  
e)  $11431 - 5316 = 6115$ ; f)  $2201 - 345 = 1856$ ; g)  $12\ 209 - 4533 = 7676$ .

*Namuna:* a)  $1559 + 599 = 2158$ . Demak, tenglik to'g'ri.

163. Ayirishni bajaring va natijani qo'shish amali bilan tekshiring:

- a)  $1\ 584 - 239$ ; e)  $65\ 432 - 12\ 345$ ;  
b)  $4\ 000 - 798$ ; f)  $18\ 644\ 538 - 7\ 974\ 683$ ;  
d)  $75\ 319 - 8\ 642$ ; g)  $200\ 000\ 000 - 88\ 748\ 345$ .

164. «Lasetti» avtomobili «Neksiya» avtomobilidan a) qanchaga uzun? b) qanchaga baland? (1- rasm).



1- rasm

165. Plastik kartochkada 125 500 so'm pul bor edi. Do'kondan 25 950 so'mlik xarid amalga oshirildi. Kartochkada necha so'm pul qoldi?

166. Avtomobil 1050 km masofani bosib o'tishi lozim. Agar u birinchi kuni 685 km yurgan bo'lsa, yana necha km yo'l yurishi kerak?



167. A va B nuqtalar orasidagi masofani toping.

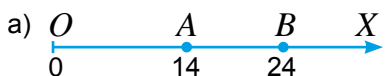

168. Sonlar nurida belgilangan nuqtalarning koordinatalarini toping. AB, BC, CA, BE va DB kesmalar uzunligini hisoblang.



169. C nuqta AB kesmada yotadi. Agar  $AB = 48$  sm va  $CB = 29$  sm ekanligi ma'lum bo'lsa, AC kesmaning uzunligini toping.

170. 1 litr suvning massasi 1 kg ga teng. 1 litr benzinning massasi esa undan 270 g kam. 1 litr benzinning massasi qancha?

171. Bir soat davomida birinchi robot (avtomatlashtirilgan dastgoh) 1745 ta, ikkinchi robot esa 2100 ta detalga ishlov berdi. Ikkinchi robot birinchisiga qaraganda nechta ko'p detalga ishlov bergan?



172. Ayirish amali xossalaridan foydalanib, qulay usulda hisoblang:

- a)  $(6\ 642 + 1\ 956) - 956$ ;      b)  $95\ 947 - (95\ 447 - 225)$ ;  
 d)  $(1\ 813 + 874) - 1\ 713$ ;      e)  $(7\ 563 + 1\ 437) - 999$ .

*Namuna:* a)  $(6642 + 1956) - 956 = 6642 + (1956 - 956) = 6642 + 1000 = 7642$ .

173. Amallarni bajaring:

- a)  $5478 - 4368 + 3479$ ;      b)  $5475 + 3011 - 1716$ ;  
 d)  $2789 + 3576 - 2428$ ;      e)  $7591 - 2439 + 3698$ .

174. 2010-yili dunyoda bo'yi eng uzun odam turkiyalik 27 yoshlik Sulton Kozen bo'lib, uning bo'yi 2 m 46 sm, eng pakana odam esa xitoylik 20 yoshli Xi Ping Ping bo'lib, uning bo'yi atigi 74 sm ni tashkil qiladi (2- rasm). Sulton Xidan qancha uzun?

175.  $AB$  kesma uzunligi 43 sm.  $C$  va  $D$  nuqtalar  $AB$  kesmada yotadi.  $D$  nuqta esa  $C$  va  $B$  nuqtalar orasida yotadi. Agar a)  $AC = 15$  sm,  $DB = 19$  sm; b)  $AD = 28$  sm,  $CB = 20$  sm bo'lsa,  $CD$  kesma uzunligini toping?

176.  $ABCD$  to'rtburchakning perimetri 100 sm.  $AB$  tomon 44 sm,  $BC$  tomon  $AB$  tomondan 15 sm qisqa, lekin  $CD$  tomondan 8 sm uzun.  $AD$  tomon uzunligini toping.



2- rasm



### Uyda bajariladigan mashqlar

177. Sonlar nurida  $C(18)$  nuqtani belgilang va undan 9 birlik chapda  $D$  va 5 birlik o'ngda joylashgan  $E$  nuqtani belgilang.  $D$  va  $E$  nuqtalarning sonlar nuridagi koordinatasini toping.

178. Ayirishni bajaring va natijani qo'shish amali bilan tekshiring:

- a)  $4\ 487 - 923$ ;      b)  $3\ 010 - 2318$ ;      d)  $19\ 334 - 15\ 722$ .

179. «Kobalt» avtomobili «Lasetti» avtomobilidan a) qanchaga qisqa? b) qanchaga baland? (3- rasm).

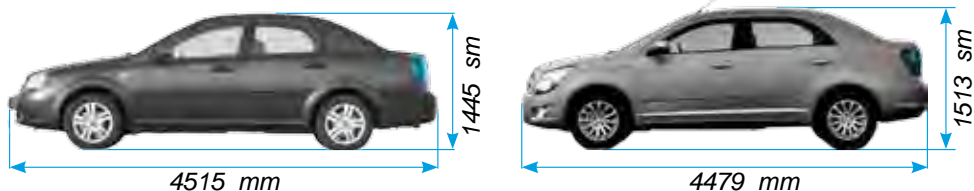

3- rasm

180. Jirafaning bo'yi 430 sm. Zebraning bo'yi esa undan 274 sm qisqa. Zebraning bo'yini toping?



181. Sonlar nurida belgilangan nuqtalarning koordinatalarini aniqlang. a)  $A$  va  $D$ ; b)  $C$  va  $B$  nuqtalar orasidagi masofani toping.



182.  $C$  nuqta  $AB$  kesmada yotadi. Agar  $AB = 24$  sm va  $CB = 15$  sm ekanligi ma'lum bo'lsa,  $AC$  kesmaning uzunligini toping.
183. Bir haftada birinchi ishchi 1745 ta, ikkinchi ishchi esa 3421 ta detal yasadi. Ikkinchi ishchi birinchisiga qaraganda nechta ko'p detal yasagan? 
- 
184. Ayirish amali xossalaridan foydalanib, qulay usulda hisoblang:  
 a)  $(3\ 426 + 2\ 345) - 345$ ;                      b)  $(3\ 453 + 898) - 2\ 353$ ;  
 d)  $12\ 387 - (12\ 187 - 887)$ ;                      e)  $(6\ 578 + 1\ 437) - 1578$ .
185. Amallarni bajaring:  
 a)  $12\ 478 - 12\ 378 + 7934$ ;                      b)  $38\ 709 + 13\ 576 - 21\ 709$ ;  
 d)  $28\ 676 + 1111 - 21\ 776$ ;                      e)  $41\ 512 + 13\ 924 - 23\ 412$ .
186. To'g'ri to'rtburchak shaklidagi maktab hovlisining bo'yi 216 m, eni esa bo'yidan 45 m qisqa. Maktab hovlisining perimetrini hisoblang.
187. «Lasetti» avtomobili massasi 1246 kg, «Kobalt» avtomobili massasi esa 1149 kg (4- rasm). «Kobalt» avtomobili «Lasetti» avtomobilidan necha kilogrammga yengil?



4- rasm

### Bilimingizni sinab ko'ring!



Bu bob materiallarini o'rganib chiqib, quyidagi masalalarni yecha olishingiz shart! Nazorat ishi oldidan o'zingizni sinab ko'ring!

### 2- nazorat ishi namunasi

- Amallarni bajaring:  
 a)  $249\ 638 + 83\ 554$ ;                      b)  $665\ 247 - 8296$ .
- a) 28 763 sonidan 9338 ga katta bo'lgan sonni toping.  
 b) 59 345 soni 53 568 sonidan qancha katta?  
 d) 59 345 soni 69 965 sonidan qancha kichik?
- Birinchi yashikda 62 kg olma bor bo'lib, bu ikkinchi yashikdagi olmadan 18 kg ga ko'p. Ikkinchi yashikda qancha olma bor?
- $MFK$  uchburchakning  $FK$  tomoni 62 sm.  $FK$  tomonidan  $KM$  tomoni 1 dm uzun,  $MF$  tomoni esa 16 sm qisqa. Uchburchak perimetrini toping va uni dm da ifodalang.
- To'g'ri chizikli yo'lak bo'ylab 15 ta buta ekildi. Butalar orasidagi masofa bir xil. Agar birinchi va oxirgi butalar orasidagi masofa 210 dm bo'lsa, qo'shni butalar orasidagi masofani toping.

## 9-§.

## SONLI VA HARFLI IFODALAR

## 9.1. Sonli ifodalar

1- rasmda tasvirlangan, tomonlari 4 sm va 6 sm bo'lgan to'g'ri to'rtburchakning perimetri nimaga teng?

Ravshanki, usbu to'rtburchakning perimetri  $2 \cdot 4 + 2 \cdot 6$  ko'rinishidagi ifoda bilan aniqlanadi.

Sonlar, arifmetik amallar va qavslardan tuzilgan bunday ifodalar *sonli ifodalar* deb ataladi.

Masalan,  $23 - (12 + 45)$  va  $12 \cdot 40 - 450 : 9$  ifodalar sonli ifodalardir.

Sonli ifodada amallar belgilangan tartibda bajarilsa, *sonli ifodaning qiymati* hosil bo'ladi.

Yuqoridagi sonli ifodaning qiymati, ya'ni to'g'ri to'rtburchakning perimetri  $2 \cdot 4 + 2 \cdot 6 = 20$  (sm) ga teng.

Tomonlari 4 sm va  $a$  sm bo'lgan to'g'ri to'rtburchakning perimetri nimaga teng bo'ladi? Bu savolga javob  $- 2 \cdot 4 + 2 \cdot a$  ko'rinishdagi ifoda bo'ladi.

Sonlar, arifmetik amallar, qavslar bilan bir qatorda harflar ham ishtirok etgan ifoda *harfli yoki harfiy ifoda* deb ataladi.

$a \cdot 40 - a \cdot b$  va  $23 - (a : c + 45)$  harfli ifodalardir.

Odatda, harfli ifodalarda son va harf yoki harflar o'rtasidagi ko'paytirish amali belgisi yozilmaydi. Shuningdek, harfiy ifodada ko'paytuvchilar son va harf bo'lsa, sonni harfdan oldin yozishga kelishilgan.

Masalan, yuqoridagi  $a \cdot 40 - a \cdot b$  harfli ifoda  $40a - ab$  tarzda yoziladi.

Harfli ifodadagi harf o'rniga turli sonlarni qo'yish mumkin. Bu sonlar *harfning qiymatlari* deb ataladi. Harfli ifodadagi harf o'rniga son qo'yib hisoblanganda chiqqan natijaga *hatfli ifodaning qiymati* deyiladi.

*1- misol.* Ishchi 2 soat ishladi. U birinchi soatda 12 dona, ikkinchi soatda esa birinchi soatdagidan  $m$  dona ko'p detal tayyorladi. Ishchi ikki soatda tayyorlagan detallar sonini ifodalaydigan harfli ifoda tuzing. Harfli ifodaning  $m$  a) 4 ga; b) 8 ga teng bo'lgandagi qiymatini toping.

*Yechish.* Avval harfli ifoda tuzamiz. Masala shartiga ko'ra, ishchi ikkinchi soatda  $12 + m$  dona detal tayyorlagan. Unda, ishchi bu ikki soat ichida  $12 + (12 + m)$  dona detal tayyorlagan bo'ladi.

a)  $12 + (12 + m)$  harfli ifodaning  $m = 4$  bo'lgandagi qiymati:  $12 + (12 + 4) = 28$ ;

b)  $12 + (12 + m)$  harfli ifodaning  $m = 8$  bo'lgandagi qiymati:  $12 + (12 + 8) = 32$ ;

*Javob.*  $12 + (12 + m)$ ; a) 28; b) 32.

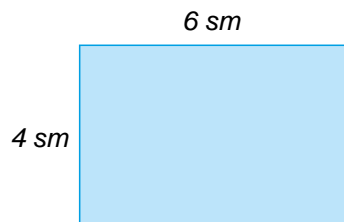

1- rasm



## Savollarga javob bering!

1. Sonli ifodalarga misollar keltiring.
2. Sonli ifodaning qiymati qanday topiladi?
3. Harfli ifoda deb qanday ifodaga aytiladi?
4. Harfli ifodaning qiymati deb nimaga aytiladi?

## Sinfda bajariladigan mashqlar



188. Sonli ifodaning qiymatini toping:

- a)  $13 \cdot 5 + 98$ ;                      b)  $127 + 108 : 3 - 24$ ;                      d)  $12 \cdot 8 + 98 - 35$ ;  
e)  $23 \cdot 4 + 121 : 11$ ;                      f)  $5 \cdot 23 + 6 \cdot 41$ ;                      g)  $455 : 5 - 13 \cdot 7 + 43$ .

189. Harfli ifodaning qiymatini toping:

- a)  $128 - b$ , bunda  $b = 31$ ; 43; 59.                      b)  $b - 18$ , bunda  $b = 39$ ; 124; 215.  
d)  $35 + x$ , bunda  $x = 0$ ; 10; 100.                      e)  $125 - x$ , bunda  $x = 0$ ; 110; 98.

**Namuna:** a)  $b = 31$  bo'lganda,  $128 - b = 128 - 31 = 97$ .

190. Harfli ifodaning qiymatini toping:

- a)  $(128 - 12b) + (14b - 18)$ , bunda  $b = 3$ ; 4; 5.  
b)  $(30y - 25) - (20y + 10)$ , bunda  $y = 4$ ; 8; 10.

**Namuna:** a)  $b = 3$  bo'lganda,  $(128 - 12b) + (14b - 18) =$   
 $= (128 - 12 \cdot 3) + (14 \cdot 3 - 18) = (128 - 36) + (42 - 18) = 92 + 24 = 116$ .



191. Azizada  $n$  ta CD-disk bor edi. Unga o'rtog'lari yana 5 ta disk sovg'a qilishdi. Azizada jami qancha disk bo'ldi?

192. Asal  $x$  yoshda, Sobir undan 8 yosh kichik. Sobirning yoshi qancha? Agar Asalning yoshi a) 10; b) 14; d) 16 ga teng bo'lganda, Sobirning yoshi qancha bo'ladi?

193. Duradgor uch kunda buyurtmani bajardi. Birinchi kuni u 24 ta, ikkinchi kuni birinchi kundan  $a$  ta ko'p va uchinchi kuni esa ikkinchi kundan 4 ta kam stul yasadi.  $a = 8$ ; 10; 12 qiymatlarda duradgor yasagan jami stullar sonini hisoblang.

## Uyda bajariladigan mashqlar



194. Sonli ifodaning qiymatini toping:

- a)  $81 : 9 + 12 \cdot 5$ ;                      b)  $127 \cdot 2 + 145 : 5$ ;                      d)  $22 \cdot 4 + 180 : 15 + 43$ .

195. Harfli ifodaning qiymatini toping.

- a)  $28 - c$ , bunda  $c = 12$ ; 24.                      b)  $d - 109$ , bunda  $d = 139$ ; 523.

196. Harfli ifodaning qiymatini toping.

- a)  $(19 - 7b) + (9b - 8)$ , bunda  $b = 1$ ; 2.  
b)  $(5a - 3) + (8a + 16)$ , bunda  $a = 1$ ; 2; 3.



197. Shohjahonda  $a$  ta kitob bor edi. U o'rtog'iga 3 ta kitobini o'qishga berdi. Shohjahon kutubxonasida qancha kitob qoldi?

198. Birinchi qalamdonda 12 ta, ikkinchisida esa birinчисidan  $m$  dona kam qalam bor. Ikkita qalamdonda nechta qalam bor?  $m = 6$ ; 8 bo'lganda masalani yeching.

199. Alisher uch kunda kitobni o'qib tugatdi. U birinchi kuni 56 bet, ikkinchi kuni birinchi kundan  $c$  bet ko'p va uchinchi kuni esa ikkinchi kundan 24 bet kam o'qidi. Kitob necha betdan iborat?  $c = 21$ ; 16 bo'lganda masalani yeching.

10-§.

**QO'SHISH VA AYIRISH XOSSALARINING HARFIY IFODASI**

Qo'shish va ayirish amallarining sizga tanish xossalarini harflar yordamida quyidagicha ifodalash mumkin:

**10.1. Qo'shish amalining xossalari**

a) *qo'shishning o'rin almashtirish qonuni:*  $a + b = b + a$ ,  
bu tenglikda  $a$  va  $b$  ixtiyoriy natural son va 0 qiymatlarini qabul qilishi mumkin.

b) *qo'shishning guruhlash qonuni:*  $a + (b + c) = (a + b) + c$ ,  
bu yerda  $a$ ,  $b$  va  $c$  ixtiyoriy natural son va 0 qiymatlarini qabul qilishi mumkin.

d) *qo'shishda nolning xossasi:*  $a + 0 = 0 + a = a$ ,  
bu yerda  $a$  – ixtiyoriy natural son va 0 qiymatlarni qabul qilishi mumkin.

**10.2. Ayirish amalining xossalari**

a) *sondan yig'indini ayirish xossasi:*  $a - (b + c) = a - b - c$ ,  
bu yerda  $a$ ,  $b$  va  $c$  sonlar  $b + c < a$  yoki  $b + c = a$  shartni qanoatlantiruvchi ixtiyoriy natural sonlar.

b) *yig'indidan sonni ayirish xossasi:*  
Agar  $a$ ,  $b$  va  $c$  sonlar  $c < b$  yoki  $c = b$  shartni qanoatlantiruvchi ixtiyoriy natural sonlar bo'lsa,  $(a + b) - c = a + (b - c)$ .

Agar  $a$ ,  $b$  va  $c$  sonlar  $c < a$  yoki  $c = a$  shartni qanoatlantiruvchi ixtiyoriy natural sonlar bo'lsa,  $(a + b) - c = (a - c) + b$ .

d) *ayirishda nolning xossasi:*  $a - 0 = a$ ;  $a - a = 0$ ,  
bu yerda  $a$  – ixtiyoriy natural son va 0 qiymatlarni qabul qilishi mumkin.

**10.3. Xossalarning ifodalarni soddalashtirishda qo'llanilishi**

Qo'shish va ayirish amallarining xossalarini qo'llash – harfli ifodalarni ixcham ko'rinishga keltirishga, ya'ni soddalashtirishga imkon beradi. Buni quyidagi misollarda namoyish qilamiz:

1- misol.  $34 + x + 23$  harfli ifodani soddalashtiring.

*Yechish:*

Qo'shishning o'rin almashtirish qonuniga ko'ra:	$34 + x = x + 34$
Bundan foydalansak:	$34 + x + 23 = x + 34 + 23 = x + (34 + 23) = x + 57$ .

*Javob:*  $x + 57$ .



2- misol.  $67 - (23 + x)$  ifodani soddalashtiring.

*Yechish:*

Sondan yig'indini ayirish xossasiga ko'ra:	$67 - (23 + x) = (67 - 23) - x = 44 - x.$
--	---

*Javob:*  $44 - x.$

3- misol.  $y - 82 - 55$  harfli ifodani soddalashtiring.

*Yechish:*

Sondan yig'indini ayirish xossasiga ko'ra:	$y - 82 - 55 = y - (82 + 55) = y - 137.$
--	--

*Javob:*  $y - 137.$

4- misol.  $184 - x - 14$  ifodani soddalashtiring.

*Yechish:*

Sondan yig'indini ayirish xossasiga ko'ra:	$184 - x - 14 = 184 - (x + 14).$
Qo'shishning o'rin almashtirish qonuniga ko'ra,	$x + 14 = 14 + x$ $184 - (x + 14) = 184 - (14 + x).$
Sondan yig'indini ayirish xossasiga ko'ra:	$184 - (14 + x) = 184 - 14 - x = 170 - x.$

*Javob:*  $170 - x.$

5- misol.  $(78 + x) - 44$  ifodani soddalashtiring.

*Yechish:*

Yig'indidan sonni ayirish xossasiga ko'ra:	$(78 + x) - 44 = (78 - 44) + x = 34 + x.$
--	---

*Javob:*  $34 + x.$

6- misol.  $y - 62 + 91$  ifodani soddalashtiring.

*Yechish:*

Ifodani yig'indi ko'rinishida yozamiz:	$y - 62 + 91 = (y - 62) + 91 =$
Yig'indidan sonni ayirish xossasiga ko'ra:	$= (y + 91) - 62 = y + (91 - 62) = y + 29.$

*Javob:*  $y + 29.$

### Savollarga javob bering!



- $a + (b + c) = (a + b) + c$  tenglik qo'shishning qaysi qonunini ifodalaydi?
- Qo'shishning o'rin almashtirish qonunini so'zlar bilan bayon eting.
- Quyida sondan yig'indini ayirish xossasi to'g'ri yozilganmi?

$$a - (b + c) = a - b + c$$

- Ayirishda nolning xossasini ayting.



### Sinfda bajariladigan mashqlar

- 200.** Harfli ifodani soddalashtiring:  
 a)  $76 + x + 45$ ;    b)  $19 + 89 + x$ ;    d)  $x + 123 + 453$ ;    e)  $324 + x + 745$ .

*Namuna:* Yuqorida ko'rilgan 1- misol.

- 201.** Harfli ifodani oldin soddalashtirib, so'ng qiymatini toping:  
 a)  $23 + m + 19$ , bu yerda  $m = 3$ ;    b)  $37 + 71 + y$ , bu yerda  $y = 12$ .

- 202.** Abdurahmon do'kondan 4000 so'mga shakar va bu puldan  $a$  so'm ko'p pulga sariyog' sotib oldi. U jami necha so'mlik xarid qilgan?

- 203.** Harfli ifodani soddalashtiring:  
 a)  $34 - (12 + x)$ ;    b)  $89 - (9 + x)$ ;    d)  $y - 671 - 90$ ;    e)  $z - 280 - 251$ .

*Namuna:* Yuqorida ko'rilgan 2- va 3- misollar.



- 204.** Harfli ifodani oldin soddalashtirib, so'ng uning qiymatini toping:  
 a)  $65 - (22 + n)$ , bu yerda  $n = 30$ ;    b)  $p + 15 + 69$ , bu yerda  $p = 12$ ;

- 205.** Harfli ifodani soddalashtiring.  
 a)  $128 - x - 89$ ;    b)  $29 - x - 27$ ;    d)  $671 - y - 90$ ;    e)  $280 - z - 251$ .

*Namuna:* Yuqorida ko'rilgan 4- misol.

- 206.** Ifodani soddalashtiring:  
 a)  $(91 + x) - 48$ ;    b)  $(66 + x) - 53$ ;    d)  $y - 39 + 72$ ;    e)  $y - 27 + 83$ .

*Namuna:* Yuqorida ko'rilgan 5- va 6- misollar.

- 207.** Harfli ifodani oldin soddalashtirib, so'ng qiymatini toping:  
 a)  $(651 + x) - 480$ , bu yerda  $x = 13$ ;    b)  $y - 93 + 21$ , bu yerda  $y = 125$ .

- 208.** Zafar ikkita tarvuz sotib oldi. Birinchi tarvuz massasi 3 kg, ikkinchisidani undan  $m$  kg og'ir. Ikkala tarvuz massalari yig'indisini ifodalovchi harfli ifoda tuzing. Ifodani soddalashtiring va a)  $m = 2$ ; b)  $m = 3$  bo'lgandagi qiymatini toping.



### Uyda bajariladigan mashqlar

- 209.**  $76 + x + 45$  ifodani soddalashtiring.

- 210.**  $19 + 89 + x$  ifodani soddalashtirib, so'ng  $x = 12$  bo'lgandagi qiymatini toping.

- 211.** Hadicha gulzorga kirib, birinchi kuni 56 ta tuvakdagi gullarga suv quydi. Ikkinchi kuni esa birinchi kundan  $p$  dona ko'p gulga suv quydi. Hadicha jami nechta gulga suv quygan? Javobni soddalashtirib yozing.

- 212.** Harfli ifodani soddalashtiring:  
 a)  $435 - (x + 45)$ ;    b)  $y - 671 - 90$ .

- 213.**  $128 - x - 89$  ifodani soddalashtiring.

- 214.**  $29 - x + 27$  ifodani soddalashtiring, so'ng  $x = 32$  bo'lgandagi qiymatini toping.

- 215.** Ifodani soddalashtiring: a)  $(91 + x) - 48$ ;    b)  $p - 47 + 78$ .

- 216.** Qovoqlardan birining massasi 9 kg, ikkinchisining massasi esa birin-chisidani  $n$  kg ga kam. Qovoqlarning umumiy massasi qancha? Javobni soddalashtiring va a)  $n = 3$ ; b)  $n = 5$  bo'lgandagi qiymatini toping.

### 11.1. Tenglama tushunchasi

Masala sharti soʻzlar bilan ifodalanadi. Eʼtibor bergan boʻlsangiz, har bir masala shartida baʼzi kattaliklar qiymati berilgan, yaʼni maʼlum boʻladi, baʼzilari esa nomaʼlum boʻladi. Ular orasidan nomaʼlum boʻlgan qaysidir kattalikning qiymatini topish talab qilinadi.

Masala matematik belgilar yordamida qayta ifodalansa, nomaʼlum kattalik qiymatini osonroq topish mumkin boʻladi. Bir necha masalani koʻraylik:

*1- misol.* Alisher bitta daftar sotib olayotib, sotuvchiga 500 soʻm berdi. Sotuvchi unga 200 soʻm qaytardi. Daftar necha soʻm turadi?

*Yechish.* Bu masalada Alisherning sotuvchiga bergan puli (500 soʻm) va sotuvchining Alisherga qaytargan qaytimi (200 soʻm) maʼlum, daftarning narxi esa nomaʼlum. Keling, nomaʼlum kattalik – daftar narxini  $x$  bilan belgilaylik.

Unda masala shartiga koʻra,  $x + 200 = 500$  ifodaga ega boʻlamiz.

Bu esa masala shartining matematik belgilar yordamida yozilgan ifodasi boʻladi.

Bu yozuv tenglikdan iborat boʻlib, uning chap tomonida harfli ifoda  $x + 200$ , oʻng tomonida esa 500 soni turibdi. Shu bilan birgalikda, unda nomaʼlum kattalik  $x$  qatnashyapti.

$x$  harfi oʻrniga turli sonlarni qoʻyib koʻrish mumkin. Natijada,  $x$  ning baʼzi qiymatlarida tenglik toʻgʻri, baʼzi qiymatlarida esa notoʻgʻri boʻladi.

Masalan,  $x + 200 = 500$  tenglik  $x = 300$  boʻlganda toʻgʻri,  $x = 200$  boʻlganda esa notoʻgʻri boʻladi. Biz  $x$  ning shunday qiymatini topishimiz kerakki, uni tenglikka qoʻyganda, toʻgʻri tenglik hosil boʻlsin. Shundagina masala yechilgan boʻladi.

Nomaʼlum qiymatini topish talab qilinayotgan harf qatnashgan tenglikka *tenglama* deb ataladi.

Nomaʼlum harfning tenglamani toʻgʻri sonli tenglikka aylantiradigan qiymati *tenglamaning ildizi (yechimi)* deb ataladi.

*Tenglamani yechish* deb, uning barcha ildizlarini topishga (yoki uning birorta ham ildizi yoʻqligini aniqlashga) aytiladi.

Masalan,  $x + 200 = 500$  tenglamaning ildizi (yechimi) 300 boʻladi.

*2- misol.* Nomaʼlum songa 12 qoʻshilganda 23 hosil boʻldi. Nomaʼlum sonni toping.

*Yechish.* Nomaʼlum sonni  $x$  harfi bilan belgilaymiz. U holda masala shartiga koʻra  $x + 12 = 23$  tenglikka ega boʻlamiz.

Ayirish amali maʼnosidan kelib chiqadigan boʻlsak, bu son 23 va 12 sonlarning ayirmasidan yaʼni  $23 - 12 = 11$  sonidan iborat boʻladi.

Demak,  $x + 12 = 23$  tenglamaning ildizi  $x = 11$ , yaʼni nomaʼlum son 11 ga teng.

**11.2. Noma'lum qo'shiluvchini topish**

*3- misol.*  $x + 23 = 57$  tenglamani yeching.

*Yechish.* Masala shartiga ko'ra ikki qo'shiluvchining yig'indisi 57 ga teng. Qo'shiluvchilardan biri noma'lum va uni topish talab qilinadi.

$$\begin{aligned}x + 23 &= 57 \\x &= 57 - 23 \\x &= 34\end{aligned}$$

Ayirish amalining ma'nosiga ko'ra noma'lum qo'shiluvchi yig'indi va ikkinchi qo'shiluvchi ayirmasiga teng.

Demak,  $x = 57 - 23$ , ya'ni  $x = 34$ .

34 soni haqiqatan ham  $x + 23 = 57$  tenglamaning ildizi bo'ladi, chunki bu sonni  $x$  ning o'rniga qo'ysak, tenglama  $34 + 23 = 57$  ko'rinisdagi to'g'ri tenglikka aylanadi.

*Javob:*  $x = 34$ .



Noma'lum qo'shiluvchini topish uchun yig'indidan ma'lum qo'shiluvchini ayirish kerak.

**11.3. Noma'lum kamayuvchini topish**

*4- misol.*  $y - 9 = 16$  tenglamani yeching.

*Yechish.* Masala shartiga ko'ra ikki son ayirmasi 16 ga teng. Kamayuvchi esa noma'lum va uni topish talab qilinadi.

$$\begin{aligned}y - 9 &= 16 \\y &= 16 + 9 \\y &= 25\end{aligned}$$

Ayirish amalining ma'nosiga ko'ra,  $y$  ning qiymati 16 va 9 sonlarining yig'indisiga teng.

Demak,  $y = 16 + 9$ , ya'ni  $y = 25$ .

25 soni haqiqatan ham  $y - 9 = 16$  tenglamaning ildizi, chunki  $25 - 9 = 16$  to'g'ri tenglik.

*Javob:*  $y = 25$ .



Noma'lum kamayuvchini topish uchun ayiriluvchini ayirmaga qo'shish kerak.

**11.4. Noma'lum ayiriluvchini topish**

*5- misol.*  $38 - z = 12$  tenglamani yeching.

*Yechish.* Masala shartiga ko'ra ikki son ayirmasi 12 ga teng. Lekin, bu safar ayiriluvchi noma'lum va uni topish talab qilinadi.

$$\begin{aligned}38 - z &= 12 \\z &= 38 - 12 \\z &= 26\end{aligned}$$

Ayirish amalining ma'nosiga ko'ra, 38 soni  $z$  va 12 sonlarining yig'indisidan iborat:

$$z + 12 = 38.$$

Bu tenglamadan noma'lum qo'shiluvchini topamiz:  $z = 38 - 12$ , ya'ni  $z = 26$ . 26 soni  $38 - z = 12$  tenglamaning ildizi, chunki  $38 - 26 = 12$  to'g'ri tenglik.

*Javob:*  $z = 26$ .



Noma'lum ayiriluvchini topish uchun kamayuvchidan ayirmani ayirish kerak.

**6- misol.**  $(x + 43) - 23 = 52$  tenglamani yeching.

**Yechish.** Bu tenglamani ikki xil usulda yechish mumkin.

**1-usul.** Tenglamaning chap qismini  $(x + 43)$  va 23 sonlarining ayirmasi sifatida olib, oldin noma'lum kamayuvchi  $(x + 43)$  ni topamiz:

$$\begin{aligned} (x + 43) - 23 &= 52 \\ x + 43 &= 52 + 23 \\ x + 43 &= 75 \\ x &= 75 - 43 \\ x &= 32 \end{aligned}$$

$$(x + 43) = 52 + 23, \quad x + 43 = 75.$$

So'ng oxirgi tenglamadagi noma'lum qo'shiluvchini topamiz:

$$x = 75 - 43 = 32.$$

**Javob:**  $x = 32$ .

**2-usul.** Oldin tenglamaning chap qismida turgan  $(x + 43) - 23$  ifodani ayirish amali xossasidan foydalanib soddalashtiramiz:

$$(x + 43) - 23 = x + 43 - 23 = x + 20.$$

So'ng uni tenglamaga qo'yamiz:

$$x + 20 = 52.$$

Bu tenglamadan noma'lum qo'shiluvchini topamiz:

$$x = 52 - 20,$$

**Javob:**  $x = 32$ .

Ko'rib turganingizdek, har ikkala holda ham tenglama ildizi bir xil chiqdi.

### Savollarga javob bering!



1. Tenglamaning ildizi nima?
2. Tenglamaning ildizi to'g'ri topilgani qanday tekshiriladi?
3. Noma'lum qo'shiluvchi qanday topiladi?
4. Noma'lum kamayuvchi qanday topiladi?
5. Noma'lum ayiriluvchini topish uchun nima qilish kerak?

### Sinfda bajariladigan mashqlar



**217.** Tenglamada nima ma'lum va nima noma'lumligini aniqlang va uni yeching.

**Namuna:** Yuqorida ko'rilgan 3-, 4- va 5- misollar.

a)  $x + 45 = 79$ ;

e)  $y - 3072 = 1136$ ;

b)  $1306 + x = 2176$ ;

f)  $796 - z = 423$ ;

d)  $y - 463 = 361$ ;

g)  $2609 - z = 1423$ .

**218.** 3260 va 4521 sonlarining yig'indisi 7781 ga teng ekanligidan foydalanib, hisob-kitoblarsiz quyidagi sonli ifodalarning qiymatini va tenglamalarning ildizini ayting:

a)  $7781 - 3260$ ;

e)  $x - 3260 = 4521$ ;

b)  $7781 - 4521$ ;

f)  $y - 4521 = 3260$ ;

d)  $4521 + 3260$ ;

g)  $z + 3260 = 7781$ .

219. Rasmga ko'ra tenglama tuzing va uni yeching.

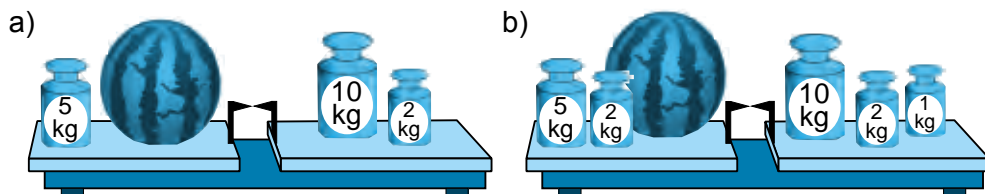

220. 23, 45, 12 sonlardan qaysi biri  $x + 45 = 57$  tenglamaning ildizi bo'ladi?



221. Asilbek jamlamasiga 26 ta marka qo'shgandan so'ng uning markalari soni 142 taga yetdi. Asilbekda dastlab nechta marka bo'lgan?

222. Omborga 34 t yuk keltirilgandan so'ng ombordagi jami yuk 143 tonnaga yetdi. Omborda dastlab qancha yuk bo'lgan?

223. Rasmga ko'ra tenglama tuzing va uni yeching:

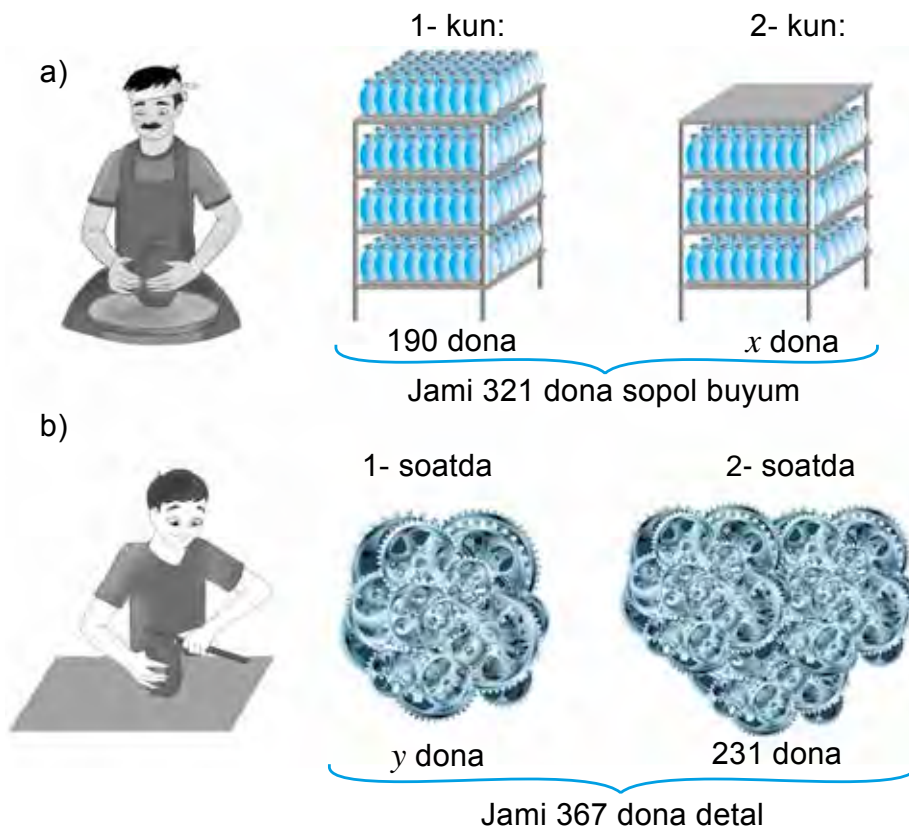

224. Qutiga 345 dona shokolad solingandan so'ng undagi jami shokoladlar soni 423 donaga yetdi. Dastlab qutida nechta shokolad bo'lgan?

225. Omborga 89 yashik uzum keltirilgandan so'ng, uzum solingan yashiklar soni 174 taga yetdi. Dastlab omborda qancha uzum bo'lgan?

**226.** Botir bir son o'yladi. Agar unga 74 ni qo'shib, hosil bo'lgan yig'indiga yana 21 qo'shilsa, 142 hosil bo'ladi. Botir qaysi sonni o'ylagan?



**227.** Tenglamani ikki usulda yechib, uning to'g'ri yechilganligini tekshiring:

a)  $(x + 24) - 12 = 79$ ;

b)  $(y - 29) + 45 = 76$ ;

d)  $(122 + x) - 291 = 157$ ;

e)  $784 + (y - 165) = 869$ ;

f)  $(x + 3013) + 2222 = 7162$ ;

g)  $542 - (y - 307) = 148$ .

*Namuna:* Yuqorida ko'rilgan 6- misol.

**228.** Rasmga qarab tenglama tuzing va uni yeching.

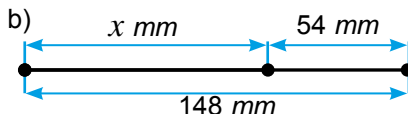
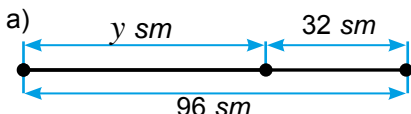

**229.** Ilhomda  $x$  dona, Botirda undan 8 dona ko'p, Dilshodda esa Ilhomdan 3 dona kam daftar bor. Ularda jami 62 ta daftar borligi ma'lum bo'lsa, Ilhomda qancha daftar borligini aniqlang.

**230.** Uchta idishda jami 144 litr sut bor. Birinchi idishda  $y$  litr, ikkinchi idishda birinchisiga qaraganga 12 litr kam, uchinchi idishda esa 24 litr ko'p sut bor. Birinchi idishda qancha sut bor?

**231.** Uchta kesmaning uzunliklari yig'indisi 143 dm. Birinchi kesma uzunligi  $x$  dm bo'lib, u ikkinchi kesmadan 23 dm qisqa, uchinchi kesmadan esa 21 dm uzun. Birinchi kesma uzunligini toping.

### Uyda bajariladigan mashqlar



**232.** Tenglamani yeching:

a)  $x + 72 = 89$ ;

b)  $x + 4205 = 6365$ ;

d)  $y - 62 = 29$ ;

e)  $y - 614 = 3112$ ;

f)  $74 - z = 13$ ;

g)  $1556 - z = 221$ .

**233.** 16, 54, 22 sonlardan qaysi biri  $x + 69 = 91$  tenglamaning ildizi bo'ladi?

**234.** 5613 va 2123 sonlarining ayirmasi 3490 ga teng ekanligidan foydalanib, hisob-kitoblarsiz quyidagi sonli ifodalarning qiymatini va tenglamalarning ildizini ayting:

a)  $5613 - 2123$ ;

b)  $5613 - 3490$ ;

d)  $2123 + 3490$ ;

e)  $x - 2123 = 3490$ ;

f)  $y - 2123 = 3490$ ;

g)  $z + 2123 = 5613$ .



**235.** Qutiga 647 ta gugurt donasi solingandan so'ng undagi jami gugurt donalari soni 1121 taga yetdi. Dastlab qutida nechta gugurt donasi bo'lgan?

**236.** Bochkaga 214 litr suv solingandan so'ng, undagi suv miqdori 391 litrga yetdi. Dastlab idishda qancha suv bo'lgan?

**237.** G'altakda jami 2495 m sim bor edi. Undan 897 m sim kesib olindi. G'altakda qancha sim qoldi?

**238.** Rasmga ko'ra tenglama tuzing va uni yeching:

a)

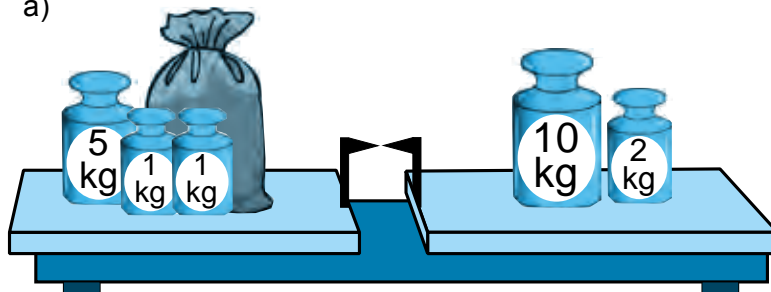

b) Bor edi:

Sotildi:

Qoldi:



423 dona



165 dona



$x$  dona

**239.** Hamdam bir son o'yladi. Agar unga 45 ni qo'shib, hosil bo'lgan yig'indiga yana 32 qo'shilsa, 84 hosil bo'ladi. Hamdam qaysi sonni o'ylagan?

**240.** Tenglamani yeching va yechimni tekshiring:

a)  $(x + 33) - 39 = 82;$

b)  $(y - 37) + 21 = 69;$

d)  $(12 + x) - 129 = 409;$

e)  $(x + 6275) + 1231 = 9177.$

**241.** Azizada  $x$  dona, Nargizada undan 8 dona ko'p, Dilnozada esa Azizadan 3 dona kam kitob bor. Jami opa-singillarda 35 ta kitob bor bo'lsa, Azizada nechta kitob bor?

**242.** Uchta kesmaning uzunliklari yig'indisi 244 sm. Birinchi kesma uzunligi  $y$  sm bo'lib, u ikkinchi kesmadan 13 sm uzun, uchinchi kesmadan esa 65 sm qisqa. Birinchi kesma uzunligini toping.

**243.** Rasmga ko'ra tenglama tuzing va uni yeching.

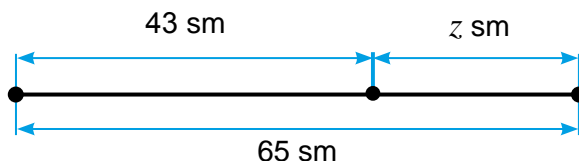



12-§.

II BOBNI TAKRORLASHGA DOIR MASALALAR

12.1. Masala yechishning tenglashtirish usuli

1- misol. Ikki bog‘lamda jami 70 ta daftar bor. Ikkinchi bog‘lamda birinchisiga qaraganda 10 ta daftar ko‘p. Har bir bog‘lamda nechtadan daftar bor?

*Yechish.* Xayolan bog‘lamlardagi daftarlar sonini tenglashtiramiz (1- rasm). Buning uchun ikkinchi bog‘lamdan 10 ta daftarni olamiz. Unda ikki bog‘lamda jami  $70 - 10 = 60$  ta daftar qoladi.

Endi har bir bog‘lamdagi daftarlar soni tenglashdi va u  $60 : 2 = 30$  ta daftarga teng.

Shu tariqa, birinchi bog‘lamda 30 ta daftar borligini aniqladik. Unda, shartga ko‘ra ikkinchi bog‘lamda birinchisidan 10 ta ko‘p  $30 + 10 = 40$  (ta) daftar bo‘ladi.

*Javob:* Birinchi bog‘lamda 30 ta, ikkinchisida 40 ta daftar bor.

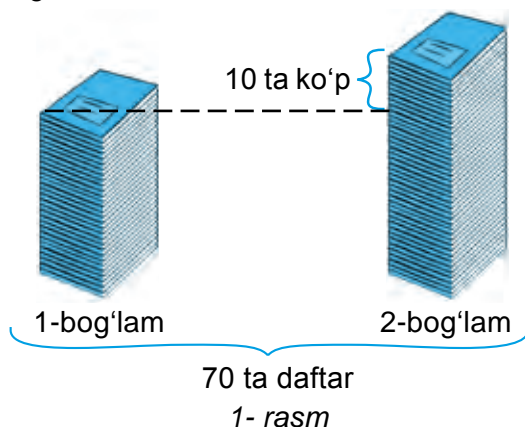

2- misol. Uchta javonda 47 ta kitob bor. Ikkinchi javonda birinchisidan 4 ta kam, uchinchisidan 2 ta ko‘p kitob bor. Birinchi javonda nechta kitob bor?

*Yechish.* Masala shartiga ko‘ra sxematik rasm chizamiz (2- rasm). Xayolan uchinchi javonga 6 ta, ikkinchi javonga esa 4 ta kitobni qo‘yib, javondagi kitoblar sonini tenglashtiramiz. Unda, har uchala javondagi jami kitoblar soni:

$47 + 10 = 57$  (ta) ga teng bo‘ladi.

Demak, birinchi javondagi kitoblar soni:  $57 : 3 = 19$  (ta) bo‘ladi.

*Javob:* Birinchi javonda 19 ta kitob bor.

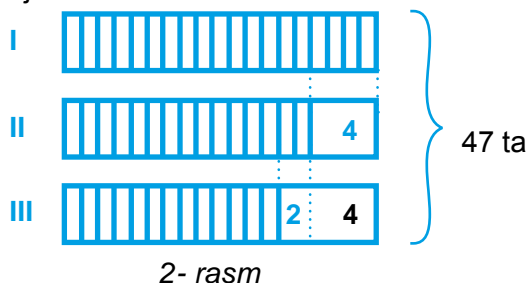

3- misol. Ikkita javonda 12 ta kitob bor. Birinchi javondan ikkinchi javonga, ikkinchi javonda nechta kitob bo‘lsa, shuncha kitob olib qo‘yilsa, javonlardagi kitoblar soni tenglashadi. Dastlab javonlarning har birida nechtadan kitob bo‘lgan? (Bu masalani mustaqil yeching).

## 12.2. Faraz qilish usuli bilan yechiladigan masalalar

**4- misol. Qadimgi Xitoy masalasi.** Qafasda tustovuq va quyonlar boqilmoqda. Ularning jami boshi 35 ta, jami oyoqlari esa 94 ta. Qafasda nechta tustovuq va nechta quyon bor?

**Yechish.** Faraz qilaylik, qafas tepasiga sabzi qo'yildi. Barcha quyonlar sabzini yeyish uchun oldingi oyoqlarini ko'tarib, orqa oyoqlarida turib olishadi. Bu holatda qafasdagi jonivorlarning nechta oyoqlari yerda bo'ladi?

Ravshanki,  $35 \cdot 2 = 70$  (ta) oyoq yerda bo'ladi. Lekin, shartga ko'ra oyoqlar jami soni 94 taga teng. Qolgan oyoqlar qayerda qoldi? Hisobga olinmagan oyoqlar — bu quyonlarning yerdan ko'tarib turgan oldingi oyoqlaridir. Ular nechta?

$$94 - 70 = 24 \text{ (ta)}$$

Unda, bu 24 ta oldingi oyoqlar nechta quyonga tegishli?

$$24 : 2 = 12 \text{ (ta) quyonga tegishli.}$$

Demak, quyonlar soni 12 ta ekan. Unda, tustovuqlar soni  $35 - 12 = 23$  ta bo'ladi.

**Javob:** Qafasda 23 ta tustovuq va 12 ta quyon bor.

**5-misol.** Bir nechta bolalarga daftarlarni bo'lib berish kerak. Agar har bir bolaga 10 tadan daftar berilsa, 6 ta daftar ortib qoladi. Agar 11 tadan berilsa, 5 ta daftar yetmay qoladi. Bolalar sonini toping.

**Yechish.** Har bir bolaga 10 tadan daftar beramiz. Unda masala shartiga ko'ra, 6 ta daftar ortib qoladi. Ortib qolgan 6 ta daftarni ham bolalarga bittadan berib chiqamiz. Natijada, 6 ta bolada 11 tadan, qolgan bolalarda esa 10 tadan daftar bo'ladi. Lekin, masala shartiga ko'ra, bolalarga 11 tadan daftar berilganda, 5 ta daftar yetmay qolar edi.

Demak, daftar yetmay qolgan bolalar soni 5 ta ekan. Unda jami bolalar soni  $6 + 5 = 11$  ta ekan.

**Javob.** Bolalar soni 11 ta.

**6-misol.** Qo'riqxonada jami 24 ta tuya bor. Ularning ba'zilari bir o'rkachli, qolganlari ikki o'rkachli. Agar barcha tuyalar o'rkachlari soni 41 tani tashkil qilsa, bir o'rkachli tuyalar sonini aniqlang.

**7- misol.** Sinfda 30 ta o'quvchi bor. Agar sinfdagi qizlar 3 kg dan, o'g'il bolalar 5 kg dan makulatura (qog'oz chiqtlari) yig'ishsa, sinf bo'yicha jami 122 kg makulatura yig'iladi. Sinfda nechta o'g'il bola va nechta qiz bola o'qiydi?

## 12.3. II bobga doir masalalar yechish

**244.** Hisoblang:

a)  $1890 + 57\,743$ ;

b)  $56\,467 + 32\,148$ ;

d)  $27\,560 + 1760$ ;

e)  $8534 + 34\,127$ ;

f)  $50\,340 + 2602$ ;

g)  $39\,253 + 6706$ ;

h)  $63\,705 + 81\,453$ ;

i)  $5296 + 42\,831$ ;

j)  $35\,002 + 2326$ .

**245.** Tomorqadan birinchi kuni 126 kg, ikkinchi kuni birinchi kundagidan 36 kg kam qulupnay terib olindi. Uchinchi kun esa ikkinchi kundagidan 53 kg ko'p qulupnay terib olindi. Uch kunda jami necha kg qulupnay terib olindi?

**246.** Yig'indini qulay usulda hisoblang:

- a)  $237 + 484 + 763$ ;      b)  $2321 + 445 + 555$ ;      d)  $1234 + 456 + 1166$ ;  
 e)  $448 + 323 + 52 + 77$ ;      f)  $342 + 347 + 158 + 653$ ;      g)  $511 + 777 + 223 + 89$ ;

**247.** Rasmga ko'ra harfli ifoda tuzing va uning qiymatini toping.

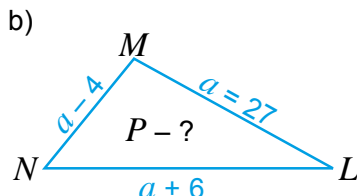
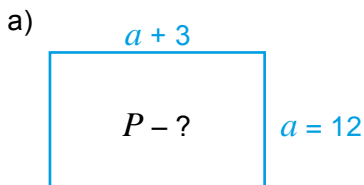

**248.** Ayirishni bajaring va natijani qo'shish amali bilan tekshiring:

- a)  $3\ 387 - 673$ ;      b)  $5\ 812 - 1\ 919$ ;      d)  $87\ 174 - 65\ 822$ ;

**249.** Sonlar nurida belgilangan nuqtalarning koordinatalarini toping.  $MN$ ,  $NL$ ,  $MK$ ,  $KN$ ,  $NO$ ,  $KM$ ,  $KL$ ,  $LM$ ,  $ML$ ,  $NL$  kesmalarning uzunligini toping.

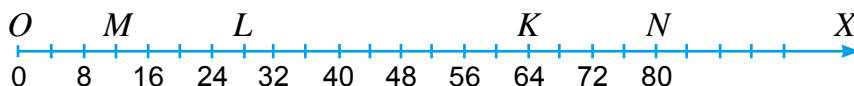

**250.** 3- rasmdagi noma'lum tosh massasini toping.

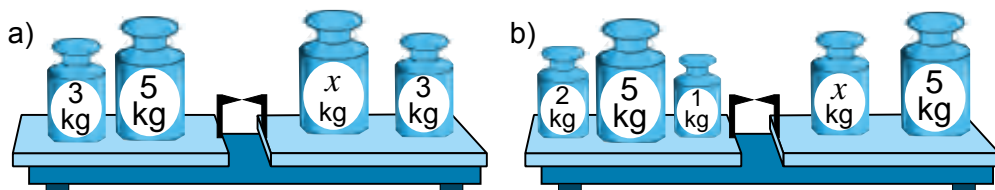

3- rasm

**251.**  $PQ$  kesmada  $S$  nuqta olingan. Agar  $PQ = 43$  sm va  $PS = 32$  sm ekanligi ma'lum bo'lsa,  $SQ$  kesmaning uzunligini toping.

**252.** Do'konda birinchi kuni 1745 dona, ikkinchi kuni esa 2242 dona tovar sotildi. Ikkinchi kuni birinchi kunga qaraganda nechta ko'p tovar sotilgan?

**253.** Ayirish amali xossalaridan foydalanib, qulay usulda hisoblang:

- a)  $(3\ 264 + 2\ 453) - 453$ ;      b)  $6\ 387 - (6\ 187 - 878)$ ;  
 d)  $(3\ 534 + 988) - 2\ 534$ ;      e)  $(26\ 785 + 1\ 437) - 11\ 785$

**254.** Amallarni bajaring:

- a)  $2478 - 2378 + 7934$ ;      b)  $8776 + 1111 - 1776$ ;  
 d)  $8709 + 3576 - 1709$ ;      e)  $4512 - 3924 + 3412$ .

- 255.** To'g'ri to'rtburchak shaklidagi xona polining bo'yi 516 sm, eni esa bo'yidan 145 sm qisqa. Xona polining perimetrini hisoblang.
- 256.** Ifodaning qiymatini toping:  
 a)  $118 - y$ , bunda  $y = 112; 94$ ;      b)  $z - 910$ , bunda  $z = 1439; 5123$ .
- 257.** Ifodaning qiymatini toping.  
 a)  $(39 - 6b) + (19b - 18)$ , bunda  $b = 1; 2$ .  
 b)  $(15a - 13) + (18a + 16)$ , bunda  $a = 1; 2; 3$ .
- 258.** Birinchi qalamdonda 24 ta, ikkinchisida esa birinchidan  $a$  dona ko'p qalam bor. Ikkita qalamdonda nechta qalam bor?  $a = 4; 18$  bo'lganda masalani yeching.
- 259.** Abdurahmon issiqxonada birinchi kuni 156 tup pomidor ko'chati ekdi. Ikkinchi kuni esa birinchi kundun  $p$  dona kam ko'chat ekdi. Abdurahmon jami nechta pomidor ko'chati ekan? Javobni soddalashtirib yozing va uning  $p = 34$  bo'lgandagi qiymatini toping.
- 260.** Ifodani soddalashtiring: a)  $2431 - (x + 247)$ ;      b)  $y - 1671 - 890$ ;  
 d)  $(291 + x) - 116$ ;      e)  $y - 234 + 387$ .
- 261.** Qovunlardan birining massasi 8 kg, ikkinchisining massasi esa birinчисinikidan  $m$  kg ga ko'p. Qovunlarning umumiy massasi qancha? Javobni soddalashtiring va a)  $m = 2$ ; b)  $m = 4$  bo'lgandagi qiymatini toping.
- 262.** 4- rasmga qarab masala tuzing va uni yeching.

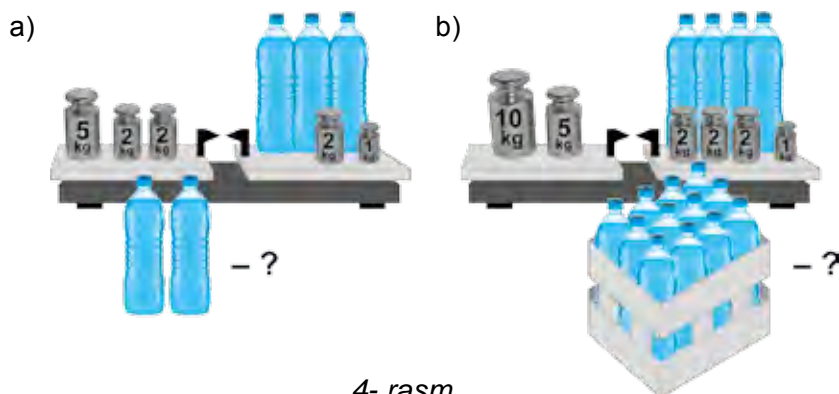

4- rasm

- 263.** Tenglamani yeching:  
 a)  $x + 231 = 389$ ;      b)  $y - 165 = 292$ ;  
 d)  $275 - z = 173$ ;      e)  $555 - z = 222$ .
- 264.** Masalani tenglama tuzib yeching:  
 a) G'altakda jami 329 m sim bor edi. Undan 129 m sim kesib olindi. G'altakda qancha sim qoldi?  
 b) Xirmonda 4570 kg paxta bor edi. Unga yana 1567 kg paxta to'kildi. Xirmonga jami qancha paxta hosili to'kilgan?  
 d) Munira bir son o'yladi. Agar unga 61 ni qo'shib, hosil bo'lgan yig'indidan 112 ayrilsa, 424 hosil bo'ladi. Munira qaysi sonni o'ylagan?

265. Tenglamani yeching va yechimni tekshiring:

a)  $(x + 13) - 19 = 32$ ;

b)  $(y - 137) + 123 = 169$ ;

d)  $(12 + x) - 12 = 40$ ;

e)  $841 + (y - 108) = 909$ .

### Matematika tarixiga oid lavhalar



#### Al-Xorazmiyning «Hisob al-hind» asari

Buyuk bobokalonimiz al-Xorazmiy o'zining «Hisob al-hind» asarida natural sonlarning o'nli sanoq sistemasida yozilishi va ular ustida qo'shish, ayirish, ko'paytirish, bo'lish amallarini bajarish qoidalarini batafsil bayon etgan. Bu asar XII asr boshlarida lotin tiliga tarjima qilingan va undan Yevropa universitetlarida uzoq yillar davomida asosiy darslik sifatida foydalanilgan. Shu tariqa Yevropaga o'nli sanoq sistemi kirib kelgan. Yevropada al-Xorazmiy nomi «Algorizmi», «Algoritmi», «Algorismus» tarzida qo'llanilgan. Xususan, hozirda tilimizga chuqur singib ketgan «algoritm» so'zi ham al-Xorazmiy nomidan olingan. Algoritm atamasining ma'nosi – biror ishni bajarishning ma'lum bir ketma-ketligi yoki qoidasini anglatadi.



### Bilimingizni sinab ko'ring!



Bu bob materiallarini o'rganib chiqib, quyidagi masalalarni yecha olishingiz shart! Nazorat ishi oldidan o'zingizni sinab ko'ring!

**Test.** To'g'ri javobni aniqlang.

- Qiymati noma'lum harf qatnashgan tenglik qanday nomlanadi?  
A. Sonli ifoda; B. Harfli ifoda; D. Ildiz; E. Tenglama.
- 12 soni qaysi tenglamaning ildizi?  
A.  $x + 3 = 12$ ; B.  $x + 13 = 25$ ; D.  $x + 6 = 12$ ; E.  $x - 3 = 12$ .
- Ayiriluvchiga ayirma qo'shilsa, nima hosil bo'ladi?  
A. Yig'indi; B. Ayirma; D. Qo'shiluvchi; E. Kamayuvchi.

### 3- nazorat ishi namunasi

- Tenglamani yeching: a)  $21 + x = 56$ ; b)  $y - 89 = 90$ .
- Ifodaning qiymatini toping:  
a)  $260 + b - 160$ , bunda  $b = 93$ ; b)  $a + c$ , bunda  $a = 20$ ,  $c = 70$ .
- Qulay usul bilan hisoblang: a)  $6485 + 1977 + 1515$ ; b)  $863 - (163 + 387)$ .
- Tenglama tuzib yeching:  
Avtobusda 78 yo'lovchi bor edi. Avtobusdan bekatda qanchadir yo'lovchi tushdi va natijada avtobusda 9 yo'lovchi qoldi. Avtobusdan qancha yo'lovchi tushgan?
- Uzunligi 20 sm bo'lgan  $MN$  kesmada  $K$  va  $F$  nuqtalar belgilandi. Agar  $MK = 15$  sm,  $FN = 13$  sm bo'lsa,  $FK$  kesma uzunligini toping.

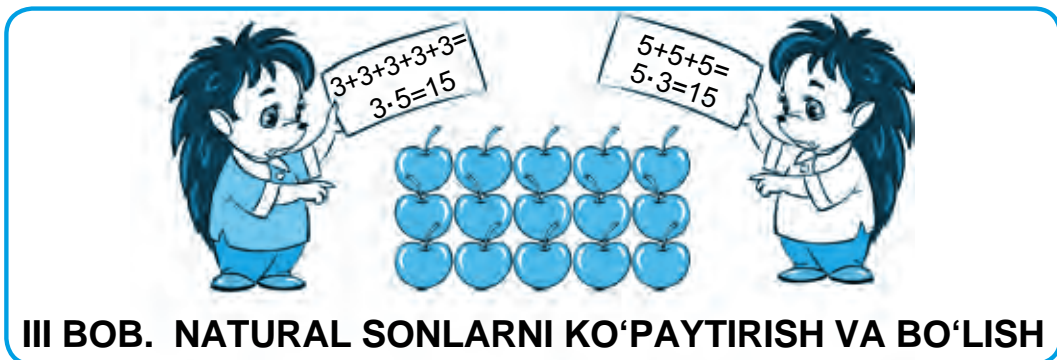

13-§.

NATURAL SONLARNI KO'PAYTIRISH VA UNING XOSSALARI

Bog'da har biri 8 tupdan 4 qator olma ko'chati ekildi (1- rasm). Shunda bog'da jami  $8 + 8 + 8 + 8$ , ya'ni 32 tup olma ko'chati ekilgan bo'ladi.

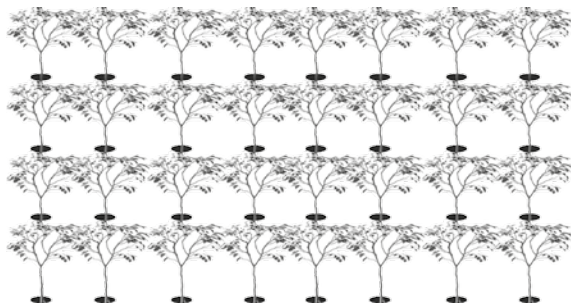

1- rasm

Qo'shiluvchilari bir-biriga teng bo'lgan  $8 + 8 + 8 + 8$  yig'indi ko'paytirish amali belgisi yordamida qisqaroq  $8 \cdot 4$  tarzida yoziladi.

Demak,  $8 \cdot 4 = 32$  ekan.



$a$  sonini  $b$  soniga ko'paytirish deganda, har biri  $a$  soniga teng bo'lgan  $b$  ta qo'shiluvchilar yig'indisini topish tushuniladi.

$$a \cdot b = \underbrace{a + a + a + \dots + a}_{b \text{ ta qo'shiluvchi}}$$

$a$  va  $b$  sonlari ko'paytmasi  $a \cdot b$  tarzida yoziladi. Bu yerda  $a \cdot b$  – ko'paytma,  $a$  va  $b$  sonlar esa ko'paytuvchilar deb ataladi.

$$\begin{array}{ccc} 8 & \cdot & 4 & = & 32 \\ \uparrow & & \uparrow & & \uparrow \\ \boxed{1\text{-ko'paytuvchi}} & & \boxed{2\text{-ko'paytuvchi}} & & \boxed{\text{ko'paytma}} \end{array}$$

Eslatib o'tamiz, 8 sonini 4 ga ko'paytirish – uni 4 marta orttirish degani.

1- misol. Qutiga meva sharbati 4 ta qator va 5 ta ustun qilib joylangan (2- rasm). Qutida nechta meva sharbati bor? Qutidagi sharbatlar sonini ikki xil usulda hisoblash mumkin:

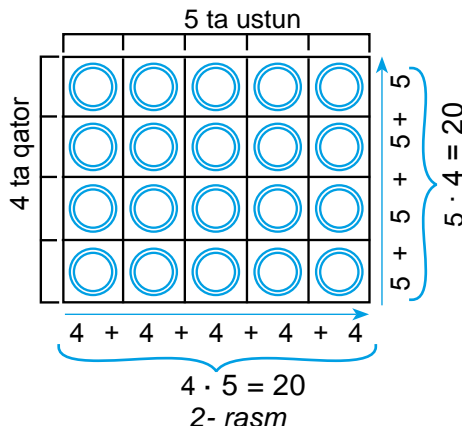

Yechish: 1- usul. Har bir qatordagi sharbatlar sonini qatorlar soniga ko'paytiramiz:

$$5 \cdot 4 = 20.$$

$$4 \cdot 5 = 20$$

2- rasm

**2- usul.** Har bir ustundagi sharbatlar sonini ustunlar soniga ko'paytiramiz:  $4 \cdot 5 = 20$ . Har ikkala holda ham bir xil natijaga egamiz.

Demak,  $5 \cdot 4 = 4 \cdot 5$ .

**Ko'paytuvchilar o'rnini almashtirgan bilan ko'paytma o'zgarmaydi.**



Bu *ko'paytirishning o'rin almashtirish xossasi* deb ataladi va u harflar yordamida quyidagicha yoziladi:

$$a \cdot b = b \cdot a$$

**2- misol.** 3- rasmda tasvirlangan qutiga 2 xil sharbat joylandi. Qutidagi sharbatlar sonini toping.

$(4 \cdot 3) \cdot 2 = 12 \cdot 2 = 24$       3- rasm

3- rasmda qutidagi sharbatlar sonini ikki xil usulda hisoblash ko'rsatilgan.

Har ikkala holda ham bir xil natijaga egamiz. Demak,  $4 \cdot (3 \cdot 2) = (4 \cdot 3) \cdot 2$ .

**Sonni ko'paytmaga ko'paytirishda sonni oldin birinchi ko'paytuvchiga ko'paytirish, so'ng esa hosil bo'lgan ko'paytmani ikkinchi ko'paytuvchiga ko'paytirish kifoya.**



Bu *ko'paytirishning guruhlash xossasi* deb ataladi va u harflar yordamida quyidagicha yoziladi:

$$a \cdot (b \cdot c) = (a \cdot b) \cdot c$$

Eslatib o'tamiz, sonni 0 va 1 ga ko'paytirishning quyidagi xossalari bor.

Ixtiyoriy  $m$  natural son uchun:  $1 \cdot m = m \cdot 1 = m$ ,  $0 \cdot m = m \cdot 0 = 0$ .

Son va harfning ko'paytmasi ko'paytirish belgisiz yoziladi:

$$8 \cdot a \text{ o'rniga } 8a \text{ yoziladi.}$$

Shunga o'xshash, qavslar oldidagi ko'paytirish belgisi ham odatda yozilmaydi:

$2 \cdot (a+b)$  o'rniga  $2(a+b)$  va  $(x+6) \cdot (y+3)$  o'rniga  $(x+6)(y+3)$  yoziladi.

Agar ko'paytmada qavslar bo'lmasa, ko'paytirish chapdan o'ngga qarab ketma-ket bajariladi.

### Savollarga javob bering!



1. Ikkita sonning ko'paytmasi deb nimaga aytiladi?
2. Bir-biriga ko'paytiriladigan sonlar qanday nomlanadi?
3. Ko'paytirish natijasi qanday nomlanadi?
4. Ko'paytirishning o'rin almashtirish xossasini tushuntiring.



## Sinfda bajariladigan mashqlar

- 266.** Ko'paytma ko'rinishida yozing va hisoblang.  
 a)  $18 + 18 + 18 + 18 + 18$ ; b)  $158 + 158 + 158$ ; d)  $a + a + a + a + a + a + a$ .
- 267.** Yig'indini oldin ko'paytmaga keltirib, so'ng hisoblang:  
 a)  $63 + 63 + 63 + 63 + 63$ ; b)  $425 + 425 + 425 + 425$ ; d)  $1202 + 1202 + 1202$ .
- 268.** Bir xil qo'shiluvchilarni guruhlab hisoblang:  
 a)  $8 + 3 + 8 + 8 + 8 + 3 + 3 + 8$ ; b)  $5 + 4 + 4 + 3 + 2 + 2 + 4 + 5 + 5 + 3 + 3 + 3$ ;
- 269.** Hisoblang:  
 a)  $14 \cdot 6$ ; b)  $22 \cdot 1$ ; d)  $14 \cdot 7$ ; e)  $15 \cdot 0$ ;  
 f)  $20 \cdot 5$ ; g)  $25 \cdot 4$ ; h)  $8 \cdot 125$ ; j)  $0 \cdot 2125$ .
- 270.** a) 56; 854; 200 sonlarini 36 marta orttiring;  
 b) 306; 2301; 3904 sonlarini 28 marta orttiring.
- 271.** Ko'paytmani hisoblang:  
 a)  $15 \cdot 9$ ; b)  $37 \cdot 59$ ; d)  $63 \cdot 24$ ; e)  $71 \cdot 86$ ;  
 f)  $712 \cdot 14$ ; g)  $607 \cdot 35$ ; h)  $872 \cdot 314$ ; i)  $4\ 609 \cdot 706$ ;  
 j)  $2\ 155 \cdot 3\ 328$ ; k)  $2\ 004 \cdot 6\ 005$ ; l)  $37 \cdot 100$ ; m)  $45\ 000 \cdot 83\ 000$ .
- 272.** Ko'paytirish amalidan foydalanib ifodani ixchamlang va uning qiymatini toping:  
 a)  $231 + 231 + 231 + 231 + 35$ ; d)  $435 + 435 + 435 + 623 + 435 + 623$ ;  
 b)  $781 + 781 + 781 + 191 + 191 + 191$ ; e)  $923 + 35 + 35 + 35 + 35 + 35 + 35$ .



- 273.** Qutida nechta meva sharbati bor?



- 274.** Ko'paytirishning guruhlash xossasidan foydalanib ko'paytmani hisoblang:  
 a)  $25 \cdot (4 \cdot 815)$ ; b)  $(111 \cdot 25) \cdot 40$ ; d)  $8 \cdot (125 \cdot 25)$ ; e)  $(122 \cdot 8) \cdot 25$ .  
*Namuna:* a)  $25 \cdot (4 \cdot 815) = (24 \cdot 4) \cdot 815 = 100 \cdot 215 = 81\ 500$ .
- 275.** Qulay usul bilan hisoblang.  
 a)  $5 \cdot 342 \cdot 2$ ; b)  $546 \cdot 5 \cdot 4$ ; d)  $4 \cdot 987 \cdot 25$ ; e)  $125 \cdot 777 \cdot 80$ .
- 276.** Qulay usul bilan hisoblang:  
 a)  $3 \cdot 5 \cdot 2 \cdot 7$ ; b)  $5 \cdot 5 \cdot 6 \cdot 4$ ; d)  $7 \cdot 2 \cdot 2 \cdot 5 \cdot 5$ ;  
 e)  $2 \cdot 9 \cdot 5 \cdot 5$ ; f)  $8 \cdot 4 \cdot 125 \cdot 25$ ; g)  $4 \cdot 2 \cdot 25 \cdot 5 \cdot 8 \cdot 125$ .  
*Namuna:* a)  $3 \cdot 5 \cdot 2 \cdot 7 = (5 \cdot 2) \cdot (3 \cdot 7) = 10 \cdot 21 = 210$ .
- 277.** Agar  $a = 1125$ ,  $b = 225$  bo'lsa,  $1034a - 934b$  ifodaning qiymatini toping.



- 278.** 1 kg konfet 5800 so'm turadi. a) 23 kg; b) 15 kg; d) 8 kg; e) 2 kg konfet qancha turadi?
- 279.**  $AB$  kesmada  $C$  nuqta olingan. Agar  $AC = 9$  sm va  $CB$  kesma  $AC$  kesmadan 4 marta uzun bo'lsa,  $AB$  kesmaning uzunligini toping.
- 280.** Dono singlisi Nargizadan 7 yosh katta. Uning yoshi otasining yoshidan 3 marta kichik. Agar Nargiza 5 yoshda bo'lsa, Dono va uning otasi yoshini toping. 
- 
- 281.** Ashraf birinchi kun kitobning 27 betini o'qidi. U ikkinchi kuni kitobning birinchi kunga qaraganda 3 marta ko'p betini o'qidi. U ikki kunda kitobning necha betini o'qigan?
- 282.** Sayohatchi birinchi kuni 12 km yo'l yurdi. U ikkinchi kuni birinchi kunga qaraganda 2 marta ko'p, uchinchi kuni esa birinchi kunga nisbatan 3 marta ko'p yo'l bosdi. Sayohatchi uch kunda qancha masofani bosib o'tgan?
- 283.** Velosipedchi uyidan manzilga 6 km/soat tezlik bilan harakatlanib, 4 soatda yetib keldi. Agar u qaytishda tezligini 2 km/soatga oshirsa, uyiga qancha vaqtda qaytib boradi?
- 284.** Ko'paytmalarni taqqoslang:  
a)  $21 \cdot 64$  va  $38 \cdot 79$ ; b)  $82 \cdot 19$  va  $69 \cdot 39$ .
- 285.** Amallarni bajaring:  
a)  $204 \cdot 65 - 38 \cdot (71 - 36) + 419$ ; b)  $(547 + 4333) \cdot 35 - 205 + 70 \cdot 5$ ;  
d)  $2948 - 18 \cdot (100 - 93) + 75$ ; e)  $100001 - 11 \cdot (38 + 16) \cdot 6$ .

### Uyda bajariladigan mashqlar

- 286.** Ko'paytma ko'rinishida yozing.  
a)  $65 + 65 + 65$ ; b)  $234 + 234 + 234 + 234 + 234$ ; d)  $y + y + y + y + y + y + y + y$ .
- 287.** 19 soni 15 marta orttirilsa, qaysi son hosil bo'ladi?
- 288.** Ko'paytmani hisoblang.  
a)  $35 \cdot 7$ ; b)  $23 \cdot 91$ ; d)  $307 \cdot 15$ ;  
e)  $3\ 601 \cdot 2\ 230$ ; f)  $78 \cdot 1100$ ; g)  $390 \cdot 143$ .
- 289.** Ifodaning qiymatini toping:  
a)  $540 + 540 + 540 + 540 + 153$ ; b)  $999 + 999 + 777 + 777 + 777$ ;  
d)  $352 + 352 + 352 + 352 + 352 + 230$ ; e)  $1289 + 53 + 53 + 53 + 53 + 1289$ . 
- 
- 290.** Ko'paytirishning guruhlash xossasidan foydalanib ko'paytmani hisoblang.  
a)  $125 \cdot (8 \cdot 9815)$ ; b)  $(500 \cdot 5) \cdot 4$ ; d)  $4 \cdot (25 \cdot 725)$ ; e)  $(102 \cdot 4) \cdot 25$ .
- 291.** Qulay usul bilan hisoblang:  
a)  $50 \cdot 651 \cdot 2$ ; b)  $424 \cdot 50 \cdot 4$ ; d)  $40 \cdot 443 \cdot 25$ ; e)  $125 \cdot 395 \cdot 8$ .
- 292.**  $213 \cdot 45$  ko'paytmani hisoblang. Natijadan foydalanib, quyidagi ko'paytmalarni toping va xulosa chiqaring:  
a)  $2130 \cdot 45$ ; b)  $2130 \cdot 450$ ; d)  $21300 \cdot 4500$ ; e)  $21300 \cdot 45000$ .

293. 1 kg pishloq 8500 so'm turadi. a) 13 kg; b) 5 kg pishloq qancha turadi?
294.  $ABC$  uchburchakning  $AB$  tomoni 36 mm va u  $BC$  tomondan 3 marta qisqa. Agar uchburchak perimetri 225 mm bo'lsa,  $AC$  tomon uzunligini toping.
295. Birinchi uskunada 1 minutda 17 ta, ikkinchisida esa 19 ta detalga ishlov berish mumkin. Agar birinchi uskuna 13 minut va ikkinchi uskuna 15 minut ishlatilsa, jami nechta detalga ishlov beriladi?
296. Birinchi ishchi bir kunda 57 ta, ikkinchi ishchi esa birinchi ishchidan 12 ta kam buyum tayyorlaydi. Bu ishchilar 5 kunda nechta buyum tayyorlaydi?
297. Amallarni bajarung:  
 a)  $42 \cdot 25 - 18 \cdot (97 - 87)$ ;      b)  $(7542 + 3343) \cdot 15 - 170 \cdot 12$ .
298. Uy sharoitida bitta cho'g'lanma lampa energiyani tejevchi lampaga almashtirilsa, bir yilda 53 kg ko'mir tejaladi va 105 kg zaharli is gazining atmosferaga tarqalishining oldi olinadi. Agar 6 ta lampa almashtirilsa-chi?



## Matematika tarixiga oid lavhalar

### Al-Xorazmiy o'ylab topgan ko'paytirishning panjara (to'r) usuli

Bu usulni IX asrda buyuk bobokalonimiz, mashhur matematik olim Muhammad ibn Muso al-Xorazmiy o'ylab topgan. Sonlarni bu usulda ko'paytirish uchun ko'paytuvchilar mos ravishda to'g'ri to'rtburchakning tepa va o'ng tomoniga yozilgan. Ko'paytma esa pastda paydo bo'lgan.

Quyida bir nechta sonlar shu usulda ko'paytirilgan. Ko'paytirish jarayonini tahlil qiling va uni bajarish qoidasini toping. Topilgan qoidani keyingi bir nechta misollarda qo'llab, ko'paytmani toping.

		5	6	
	4	0	4	8
	4	5	5	4
4	9	8	4	

		1	9	4	
	2	1	8	8	2
	7	6	3	2	8
5	2	3	8	1	

		6	0	3	
	1	2	0	6	2
	2	4	0	1	2
	6	0	3		1
4	5	3	2	3	

a)  $56 \cdot 89 = 4984$ ;      b)  $194 \cdot 27 = 5238$ ;      d)  $603 \cdot 241 = 145323$ ;  
 e)  $28 \cdot 58 = \dots$ ;      f)  $234 \cdot 37 = \dots$ ;      g)  $593 \cdot 441 = \dots$

14- §.

NATURAL SONLARNI BO'LISH

14.1. Natural sonlarni bo'lish

*1- misol.* 30 ta olma 6 ta likopchaga teng qilib taqsimlandi. Har bir likopchaga nechtdan olma solingan?

*Yechish.* Har bir likopchaga solingan olmalar sonini  $c$  harfi bilan belgilaymiz. Unda, masala shartiga ko'ra,  $c$  ning shunday qiymatini topish kerakki,  $c \cdot 6 = 30$  bo'lsin.

Ravshanki,  $c = 5$  bo'ladi, chunki  $5 \cdot 6 = 30$ .

Demak, har bir likopchaga 5 tadan olma solingan.

Yuqoridagi masalada berilgan ko'paytma va bitta ko'paytuvchiga ko'ra, ikkinchi noma'lum ko'paytuvchini topdik. Berilgan ko'paytma va bitta ko'paytuvchiga ko'ra ikkinchi ko'paytuvchini topish amaliga *bo'lish* deb ataladi.

Umimiy holda  $a$  va  $b$  sonlarining *bo'linmasi (nisbati)* deb shunday  $c$  soniga aytiladiki,

$$c \cdot b = a \quad \text{bo'ladi.}$$

$a$  va  $b$  sonlarining bo'linmasi  $a : b$  tarzda belgilanadi va quyidagicha yoziladi:

$$a : b = c$$

Bu yozuvda  $a$  – *bo'linuvchi*,  $b$  – *bo'luvchi* va bo'lish natijasi  $c$  – *bo'linma* deb ataladi.

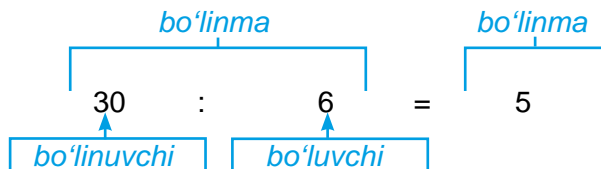

Bo'linma – bo'linuvchining bo'luvchidan *necha marta kattaligini*, yoki bo'luvchining bo'linuvchidan *necha marta kichikligini* bildiradi.

Har qanday sonni nolga bo'lish mumkin emas!



$1 \cdot a = a$  bo'lgani uchun, bo'lish amalining ma'nosiga ko'ra

$$a : 1 = a \quad \text{va} \quad a : a = 1 \quad (a \neq 0).$$

Har qanday sonni 1 ga bo'lganda yana o'sha sonning o'zi hosil bo'ladi.



$0 \cdot a = 0$  bo'lgani uchun bo'lish amalining ma'nosiga ko'ra

$$0 : a = 0.$$

Nolni har qanday natural songa bo'lganda yana nol hosil bo'ladi.



## 14.2. Bo'lish yoki ko'paytirishning to'g'ri bajarilganligini tekshirish

Bo'lish amali natijasini ko'paytirish orqali tekshirish mumkin.

*2- misol.* Aytaylik, bo'lish natijasida  $945 : 35 = 27$  hosil bo'lgan bo'lsin.

Bo'lishni to'g'ri bajarilganini bo'lish amali ma'nosidan kelib chiqib tekshiramiz. Buning uchun bo'luvchi va bo'linmani o'zaro ko'paytiramiz. Agar ko'paytma bo'linuvchiga teng chiqsa, bo'lish to'g'ri, aks holda noto'g'ri bajarilgan bo'ladi.

Bizning holda  $35 \cdot 27 = 945$ . Demak, bo'lish to'g'ri bajarilgan.

Xuddi shunga o'xshash ko'paytirishning to'g'ri bajarilganligi ko'paytmani ko'paytuvchilardan biriga bo'lish orqali tekshiriladi. Agar bo'linma ikkinchi ko'paytuvchiga teng chiqsa, ko'paytirish to'g'ri, aks holda noto'g'ri bajarilgan bo'ladi.

Masalan,  $24 \cdot 32 = 768$  ko'paytirishning to'g'ri bajarilganligi 768 ni 24 ga bo'lganda 32 (yoki 768 ni 32 ga bo'lganda 24) hosil bo'lishi bilan aniqlanadi.

## 14.3. Noma'lum ko'paytuvchini topish

*3- misol.* Tenglamani yeching:  $7 \cdot x = 84$

*Yechish.* Bo'lish amalining ma'nosiga ko'ra  $x = 84 : 7$ , ya'ni  $x = 12$ .



Noma'lum ko'paytuvchini topish uchun ko'paytmani ikkinchi ko'paytuvchiga bo'lish kerak.

$$\begin{aligned} a \cdot x &= b \\ x &= b : a \end{aligned}$$

## 14.4. Noma'lum bo'linuvchini topish

*4- misol.* Tenglamani yeching:  $x : 12 = 7$

*Yechish.* Bo'lish amalining ma'nosiga ko'ra  $x = 12 \cdot 7$ , ya'ni  $x = 84$ .



Noma'lum bo'linuvchini topish uchun bo'linmani bo'luvchiga ko'paytirish kerak.

$$\begin{aligned} x : c &= d \\ x &= d \cdot c \end{aligned}$$

## 14.5. Noma'lum bo'luvchini topish

*5- misol.* Tenglamani yeching:  $96 : x = 16$

*Yechish.* Bo'lish amalining ma'nosiga ko'ra  $x = 96 : 16$ , ya'ni  $x = 6$ .



Noma'lum bo'luvchini topish uchun bo'linuvchini bo'linmaga bo'lish kerak.

$$\begin{aligned} p : x &= q \\ x &= p : q \end{aligned}$$



## Savollarga javob bering!

1.  $a : b = c$  yozuvidagi harflar qanday nomlanadi?
2. Bo'lishning to'g'ri bajarilganligi qanday tekshiriladi?
3. Ko'paytirishning to'g'ri bajarilganligi qanday tekshiriladi?
4. Bo'linma nimani anglatadi?
5. Noma'lum bo'linuvchi qanday topiladi?
6. Noma'lum bo'luvchi qanday topiladi?



**Sinfda bajariladigan mashqlar**

**299.** Hisoblang.

- a)  $9 : 3$ ;                      b)  $18 : 6$ ;                      d)  $30 : 2$ ;                      e)  $75 : 3$ ;  
 f)  $45 : 3$ ;                      g)  $54 : 2$ ;                      h)  $24 : 2$ ;                      i)  $24 : 3$ .

**300.** Tushirib qoldirilgan sonni ayting.

- a)  $3 \cdot \dots = 36$ ;                      d)  $10 \cdot \dots = 30$ ;                      f)  $\dots : 3 = 13$ ;                      h)  $50 : \dots = 2$ ;  
 b)  $2 \cdot \dots = 50$ ;                      e)  $30 : \dots = 3$ ;                      g)  $\dots : 50 = 2$ ;                      i)  $99 : \dots = 9$ .

**301.** Bo'lishni bajaring:

- a)  $512 : 16$ ;                      b)  $1980 : 36$ ;                      d)  $1530 : 15$ ;                      e)  $1050 : 15$ ;  
 f)  $3080 : 5$ ;                      g)  $2106 : 39$ ;                      h)  $15\ 655 : 31$ ;                      i)  $31\ 108 : 44$ .

**302.** Bo'lishni bajaring. Natijani ko'paytirish orqali tekshiring:

- a)  $804 : 67$ ;                      b)  $672 : 56$ ;                      d)  $1224 : 12$ ;                      e)  $1072 : 8$ ;  
 f)  $14 : 1$ ;                      g)  $0 : 323$ ;                      h)  $9450 : 18$ ;                      i)  $1515 : 15$ .

*Namuna:* a) Bo'lish ma'nosiga ko'ra 67 ni 12 ga ko'paytirsak, ko'paytma 804 ga teng bo'lishi kerak. Haqiqatan,  $67 \cdot 12 = 804$ . Demak, bo'lish to'g'ri bajarilgan.

**303.** Ko'paytirish natijasini bo'lish orqali tekshiring:

- a)  $314 \cdot 75 = 23\ 550$ ;                      d)  $601 \cdot 852 = 512\ 012$ ;  
 b)  $502 \cdot 104 = 52\ 208$ ;                      e)  $1005 \cdot 212 = 213\ 060$ .

*Namuna:* Ko'paytmani birinchi ko'paytuvchiga bo'lsak, ikkinchi ko'paytuvchi hosil bo'lishi kerak. Haqiqatan,  $23\ 550 : 314 = 75$ . Demak, ko'paytirish to'g'ri bajarilgan.

- 304.** a) 441 559 soni 109 sonidan necha marta katta?  
 b) 306 soni 674 730 sonidan necha marta kichik?

**305.** Bitta olma massasi necha gramm? (1- rasm)

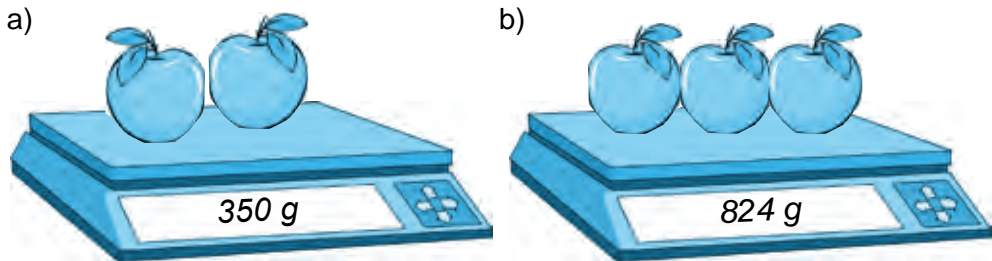

1 - rasm



**306.** Bo'lishni «burchak» usulidan foydalanmasdan bajaring. Natijani ko'paytirish yordamida tekshiring:

- a)  $254\ 254 : 254$ ;                      b)  $363\ 636 : 36$ ;                      d)  $656\ 565 : 13$ ;  
 e)  $90\ 045\ 015 : 15$ ;                      f)  $600\ 900\ 300 : 30$ ;                      g)  $350\ 175\ 070 : 35$ .

- 307.**  $32\ 046 : 7 = 4578$  ekanligidan foydalanib, quyidagi bo'linmalarni toping va xulosa chiqaring:  
 a)  $320\ 460 : 7$ ; b)  $320\ 460 : 70$ ; d)  $3\ 204\ 600 : 700$ ; e)  $32\ 046\ 000 : 7000$ .

**308.** Jadvalni to'ldiring:

$a$	8	18	24		66	72	0	75
$b$	4	3	6	7			25	1
$a \cdot b$			144	245				
$a : b$			4		6	9		

*Namuna:*  $a = 24$  va  $a \cdot b = 144$ . Demak,  $b = 144 : 24 = 6$ ,  $a : b = 24 : 6 = 4$ .

- 309.** Agar a)  $a = 23712$ ,  $b = 145$ ,  $d = 31$ ; b)  $a = 2730$ ,  $b = 438$ ,  $d = 412$  bo'lsa,  $a : (b - d)$  ifodaning qiymatini toping.
- 310.** a) 2880 sonini ko'paytuvchilardan biri 45 bo'lgan; b) 10323 sonini ko'paytuvchilardan biri 111 bo'lgan ikki son ko'paytmasi ko'rinishida tasvirlang.
- 311.** Ikki duradgor birgalikda ishlab 1456 ta stul yasadi. Agar birinchi duradgor bir kunda 32 ta, ikkinchisi esa 24 ta stul yasagan bo'lsa, ularning har biri jami nechtdan stul yasagan?



- 312.** Agar  $945 : 35 = 27$  bo'lsa, quyidagi ifodalarning qiymatini ayting:  
 a)  $27 \cdot 35$ ; b)  $945 : 27$ .

**313.** Noma'lum ko'paytuvchini toping:

- a)  $18 \cdot x = 450$ ; b)  $23 \cdot y = 2346$ ; d)  $25 \cdot a = 20\ 200$ ; e)  $356 \cdot n = 542\ 544$ .

*Namuna:*  $30 \cdot x = 23\ 310$ ,  $x = 23\ 310 : 30$ ,  $x = 777$ .

**314.** Noma'lum bo'linuvchini toping:

- a)  $x : 4 = 207$ ; b)  $y : 5 = 616$ ; d)  $a : 29 = 31$ ; e)  $b : 16 = 37$ .

*Namuna:*  $x : 44 = 23$ ,  $x = 44 \cdot 23$ ,  $x = 1012$ .

**315.** Noma'lum bo'luvchini toping:

- a)  $360 : x = 45$ ; b)  $861 : y = 41$ ; d)  $1404 : m = 52$ ; e)  $25760 : t = 230$ .

*Namuna:*  $2052 : y = 38$ ,  $y = 2052 : 38$ ,  $y = 54$ .

**316.** Tenglamani yeching:

- a)  $21 \cdot x = 903$ ; b)  $63 \cdot y = 2583$ ; d)  $986 : m = 17$ ;  
 e)  $8844 : n = 67$ ; f)  $s : 824 = 437$ ; g)  $t : 527 = 320$ .

**317.** Amallarni bajaring:

- a)  $(6444 + 756) : 72$ ; b)  $(3913 + 1313) : 13$ ;  
 d)  $(1248 - 864) : 24$ ; e)  $(9447 - 4747) : 47$ .



### Uyda bajariladigan mashqlar

**318.** Bo'lishni bajaring:

- a)  $945 : 21$ ; b)  $345 : 15$ ; d)  $1394 : 17$ ;  
 e)  $1131 : 13$ ; f)  $928 : 16$ ; g)  $9234 : 38$ .

**319.** Bo'lishni bajaring. Natijani ko'paytirish orqali tekshiring:

- a)  $1140 : 76$ ;      b)  $972 : 18$ ;      d)  $4464 : 93$ ;      e)  $14280 : 21$ .

**320.** a) 23 562 soni 231 sonidan necha marta katta?

b) 423 soni 90 522 sonidan necha marta kichik?

**321.** Bitta poliz mahsulotining massasi qancha? (2- rasm)

a)



b)



2 - rasm



**322.** Zafar qarichining uzunligi 16 sm. Uzunligi 192 sm bo'lgan arqon Zafarning qarichi bilan o'lchansa, necha qarich chiqadi?

**323.** Amallarni bajaring:

- a)  $27\ 440 \cdot 270$ ;      b)  $36\ 300 \cdot 8600$ ;      d)  $646\ 400 : 80$ ;      e)  $73\ 020\ 500 : 50$ .

**324.** 1887 sonini ko'paytuvchilardan biri 37 bo'lgan ikki son ko'paytmasi ko'rinishida tasvirlang.



**325.** Bitta banan necha gramm?

a)



b)

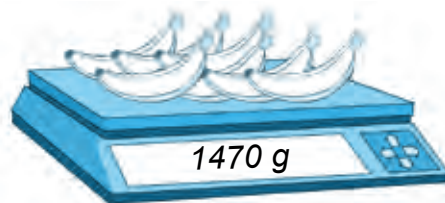

3 - rasm

**326.** Tenglamani yeching:

- a)  $13 \cdot x = 208$ ;      b)  $104 \cdot a = 5720$ ;      d)  $532 \cdot m = 113\ 316$ ;  
e)  $x : 29 = 134$ ;      f)  $a : 209 = 214$ ;      g)  $p : 103 = 871$ .

**327.** Tenglamani yeching:

- a)  $555 : x = 37$ ;      b)  $2730 : m = 65$ ;      d)  $30653 : s = 203$ ;  
e)  $107 \cdot x = 4815$ ;      f)  $1904 : m = 34$ ;      g)  $s : 281 = 211$ .

15- §.

QOLDIQLI BO'LIH

14 ta olmani uchta tipratikanga teng taqsimlash kerak bo'lsin. Bu holda har bir tipratikanga 4 tadan olma tegadi va 2 ta olma ortib qoladi (1- rasm).



1- rasm

Demak, 14 soni 3 ga bo'linmaydi. Buni

$$\begin{array}{r} -14 \overline{)3} \\ \underline{12} \phantom{0} \\ 2 \phantom{0} \end{array}$$

yoki

$$14 = 3 \cdot 4 + 2$$

ko'rinishda ifodalash mumkin. Bu holda 14 soni 3 ga *qoldiqli bo'linadi* deyiladi va 14 – *bo'linuvchi*, 3 – *bo'luvchi*, 4 – *to'liqsiz bo'linma* va 2 – *qoldiq* deb ataladi.

$$\begin{array}{r} -14 \overline{)3} \\ \underline{12} \phantom{0} \\ 2 \phantom{0} \end{array}$$

*bo'linuvchi*  
*bo'luvchi*  
*to'liqsiz bo'linma*  
*qoldiq*

$$14 = 3 \cdot 4 + 2$$

*bo'linuvchi*      *bo'luvchi*  
*to'liqsiz bo'linma*      *qoldiq*

2- rasm



Har doim qoldiq bo'luvchidan kichik bo'ladi.

Haqiqatan ham, 2- rasmda tasvirlangan qoldiqli bo'lishda qoldiq – 2 to'liqsiz bo'linma – 4 dan kichik.

Yuqoridagi  $14 = 3 \cdot 4 + 2$  tenglikdan quyidagi qoidani hosil qilamiz:



Qoldiqli bo'lishda bo'linuvchini topish uchun, to'liqsiz bo'linmani bo'luvchiga ko'paytirib, hosil bo'lgan ko'paytmaga qoldiqni qo'shish kifoya.

Agar qoldiq nolga teng bo'lsa, bo'linuvchi bo'luvchiga *qoldiqsiz bo'linadi* deyiladi.



**Savollarga javob bering!**

1. Natural son ikkinchisiga har doim qoldiqsiz bo'linadimi? Misol keltiring.
2. Bo'lishda qoldiq bo'luvchidan katta bo'lishi mumkinmi?
3.  $27 = 6 \cdot 4 + 3$  sonli ifodada qatnashgan har bir son qanday nom bilan ataladi?
4. To'liqsiz bo'linma, bo'luvchi va qoldiqqa ko'ra bo'linuvchi qanday topiladi?



**Sinfda bajariladigan mashqlar**



- 328.** Quyida berilgan sonlardan birinchisi ikkinchisiga qoldiqsiz bo'linadimi?  
 a) 9 va 3; b) 12 va 5; d) 18 va 6; e) 20 va 8; f) 0 va 34; g) 124 va 5.
- 329.** Sonni 8 ga bo'lganda, a) 0; b) 2; d) 5; e) 7; f) 12 qoldiq qolishi mumkinmi?
- 330.** Sonlarni a) 2 ga; b) 7 ga; d) 11 ga; e) 15 ga bo'lganda, qoldiq necha bo'lishi mumkin?
- 331.** Bitta choyshab tikishga 6 m mato sarflanadi. 200 m matodan nechta choyshab tikish mumkin? Shunda qancha mato ortib qoladi?
- 332.** Qoldikli bo'lishni bajaring:  
 a)  $546 : 5$ ; b)  $308 : 7$ ; d)  $210 : 19$ ;  
 e)  $1230 : 7$ ; f)  $12655 : 63$ ; g)  $54103 : 44$ .
- 333.** Tenglikni qoldikli bo'lish orqali tekshiring. Bo'linuvchi, bo'luvchi, to'liqsiz bo'linma va qoldiqni ayting:  
 a)  $2053 = 84 \cdot 24 + 37$ ; b)  $4106 = 79 \cdot 51 + 77$ ;  
 d)  $2891 = 1000 \cdot 2 + 891$ ; e)  $1230 = 94 \cdot 13 + 8$ .



- 334.** Shunday sonni topingki, uni:  
 a) 32 ga bo'lganda, 24 hosil bo'lib, 13 qoldiq qolsin;  
 b) 43 ga bo'lganda, 25 hosil bo'lib, 17 qoldiq qolsin;  
 d) 119 ga bo'lganda, 31 hosil bo'lib, 29 qoldiq qolsin.
- Namuna:* a) Ma'lumki, qoldikli bo'lishda bo'linuvchini topish uchun to'liqsiz bo'linmani bo'luvchiga ko'paytirib, hosil bo'lgan ko'paytmaga qoldiqni qo'shish kerak. Demak, izlanayotgan son  $32 \cdot 24 + 13$  ga ya'ni 781 ga teng bo'ladi.
- 335.** Yig'ilgan 770 t bug'doy hosilini temiryo'l orqali un zavodiga tashish kerak. Har bir yuk vagoniga 60 t bug'doy sig'adi. Hamma hosilni zavodga tashish uchun nechta yuk vagoni kerak bo'ladi? Oxirgi vagonga qancha bug'doy yuklanadi?
- 336.** Maktab ma'muriyati har bir bitiruvchi o'quvchiga sovg'a qilish uchun 370 dona gul xarid qildi. Har bir o'quvchiga 3 donadan gul berildi va 1 dona gul ortib qoldi. Maktab bitiruvchi o'quvchilarining soni qancha?

- 337.** Jadvalni to'ldiring:

Bo'linuvchi	Bo'luvchi	To'liqsiz bo'linma	Qoldiq
837	73		
721		45	
	43	71	27

- 338.** Botir buvisining tavallud kuniga guldasta sovg'a qilish uchun gul bozoridan 55 dona gul xarid qildi. Guldasta uchun Botir sotuvchiga 10 000 so'm pul berdi. Sotuvchi esa unga 100 so'm qaytardi. Bir dona gul narxi qancha?
- 339.** Ko'paytirishni qulay usul bilan bajaring:  
 a)  $39 \cdot 25 \cdot 4$ ; d)  $134 \cdot 5 \cdot 20$ ; f)  $33 \cdot 125 \cdot 8$ ;  
 b)  $40 \cdot 239 \cdot 25$ ; e)  $56 \cdot 50 \cdot 20$ ; g)  $134 \cdot 250 \cdot 4$ .
- 340.** Amallarni bajaring:  
 a)  $130\ 536 : 444 - 5829 : 87 + 58\ 606$ ; b)  $14 \cdot (3600 \cdot 18 - 239\ 200 : 46)$ .



## Uyda bajariladigan mashqlar

341. Qutidagi 10 kilogramm choy 150 grammdan qilib qadoqlandi. Qadoqlangandan so'ng qutida qancha choy qoladi?
342. Shirinning 5000 so'm puli bor. U bu puliga narxi 450 so'm bo'lgan muzqaymoqdan ko'pi bilan nechta sotib olishi mumkin? Shunda Shirinning yana qancha puli ortib qoladi?
343. Qoldiqli bo'lishni bajaring:
- a)  $398 : 13$ ;                      b)  $271 : 18$ ;                      d)  $1342 : 43$ ;  
 e)  $5620 : 67$ ;                      f)  $33\ 655 : 234$ ;                      g)  $10\ 354 : 233$ .



344. Shunday sonni topingki, uni:
- a) 44 ga bo'lganda, 39 hosil bo'lib, 36 qoldiq qolsin;  
 b) 123 ga bo'lganda, 66 hosil bo'lib, 100 qoldiq qolsin;
345. Bog'chaga mashinada 200 litr sut keltirildi. Sutni quyib olish uchun sig'imi 32 litr bo'lgan bidonlardan nechitasi kerak bo'ladi? Oxirgi bidonga qancha sut quyiladi?

346. Jadvalni to'ldiring:

Bo'linuvchi	Bo'luvchi	To'liqsiz bo'linma	Qoldiq
3425	89		
22 340		171	
	281	77	23

347. Zavod omboridagi 15 t 750 kg paxta 155 kg dan qilib toylandi. Necha dona paxta toyi hosil bo'ldi? Omborda yana qancha paxta ortib qoldi?
348. Qaysi holda arzon xarid amalga oshiriladi?

1 kg  
4 500 so'm

2 kg  
8 500 so'm



### Bilimingizni sinab ko'ring!

Bu bob materiallarini o'rganib chiqib, quyidagi masalalarni yecha olishingiz shart. Nazorat ishi oldidan o'zingizni sinab ko'ring.

#### 4- nazorat ishi namunasi

- Hisoblang:  
a)  $67 \cdot 189$ ;                      b)  $306 \cdot 805$ ;                      d)  $38\ 130 : 186$ .
- Tenglamani yeching:  
a)  $x \cdot 13 = 182$ ;                      b)  $187 : y = 17$ .
- Qulay usul bilan hisoblang:  
a)  $4 \cdot 283 \cdot 25$ ;                      b)  $7 \cdot 137 \cdot 125$ ;                      d)  $50 \cdot 31 \cdot 20$ .
- Masalani tenglama tuzib yeching:  
Maryam bir son o'yladi. Uni 4 ga ko'paytirib, ko'paytmaga 8 ni qo'shdi. Natijada 60 hosil bo'ldi. Maryam qanday sonni o'ylagan?
- Tenglamani ildizini toping:  $y - 25 = 10$ .

16- §.

IFODALARNI SODDALASHTIRISH

**Faollashtiruvchi mashq**

*Misol.* Yuvinish xonasi poli 4 qator ikki xil rangdagi plitkalar bilan qoplandi (1- rasm). Har bir qatorga 3 ta qizg'ish va 5 ta oq rangdagi plitkalar yotqizildi. Yuvinish xonasi poliga nechta plitka yotqizilgan?

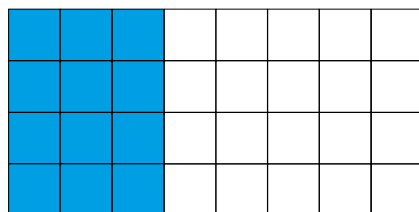

1-rasm

*Yechish.* Bu masalani ikki xil usulda yechish mumkin.

*1- usul.* Oldin har bir qatorga yotqizilgan plitkalar sonini aniqlaymiz:  $3 + 5$ . So'ng yig'indini qatorlar soni 4 ga ko'paytiramiz:

$$(3 + 5) \cdot 4 = 8 \cdot 4 = 32.$$

*2- usul.* Oldin jami yotqizilgan qizg'ish va oq plitkalar sonini aniqlaymiz:

$$\text{Qizg'ish rangli plitka} - 3 \cdot 4 \text{ ta,}$$

$$\text{Oq rangli plitka} - 5 \cdot 4 \text{ ta.}$$

So'ng ularni qo'shamiz:

$$3 \cdot 4 + 5 \cdot 4 = 12 + 20 = 32.$$

Har ikkala holda ham javob bir xil: yuvinish xonasi poliga jami 32 ta plitka yotqizilgan.

**16.1. Ko'paytirishning qo'shishga nisbatan taqsimot qonuni**

Yuqoridagi masalani ikki usulda yechib

$$(3 + 5) \cdot 4 = 3 \cdot 4 + 5 \cdot 4$$

ekanligini aniqladik.

Yig'indini songa ko'paytirish uchun qo'shiluvchilarning har birini bu songa ko'paytirish va hosil bo'lgan ko'paytmalarni qo'shish kifoya.

Bu xossa *ko'paytirishning qo'shishga nisbatan taqsimot qonuni* deb yuritiladi. Harflar yordamida bu qonun

$$(a + b) \cdot c = a \cdot c + b \cdot c$$

ko'rinishda ifodalanadi.

Ko'paytirishning qo'shishga nisbatan taqsimot qonuni ixtiyoriy sondagi qo'shiluvchilar uchun ham o'rinli bo'ladi.

**16.2. Ko'paytirishning ayirishga nisbatan taqsimot qonuni**

$(8 - 3) \cdot 4$  va  $8 \cdot 4 - 3 \cdot 4$  ifodalarning qiymati ham bir xil songa teng:

$$(8 - 3) \cdot 4 = 5 \cdot 4 = 20, \quad 8 \cdot 4 - 3 \cdot 4 = 32 - 12 = 20.$$

Demak,

$$(8 - 3) \cdot 4 = 8 \cdot 4 - 3 \cdot 4.$$

Ayirmani songa ko'paytirish uchun kamayuvchi va ayriluvchini alohida-alohida shu songa ko'paytirish va birinchi ko'paytmadan ikkinchisini ayirish kifoya.

Bu xossa *ko'paytirishning ayirishga nisbatan taqsimot qonuni* deb yuritiladi.

Uni harflar bilan

$$(a - b) \cdot c = a \cdot c - b \cdot c$$

ko'rinishida ifodalash mumkin.

Ko'paytirishning qo'shish va ayirishga nisbatan taqsimot qonunlaridan hisoblashlarni yengillashtirish uchun ham foydalanish mumkin.

1- misol. a)  $62 \cdot 7 = (60 + 2) \cdot 7 = 60 \cdot 7 + 2 \cdot 7 = 420 + 14 = 434$ ;

b)  $59 \cdot 6 = (60 - 1) \cdot 6 = 60 \cdot 6 - 1 \cdot 6 = 360 - 6 = 354$ .

### 16.3. Qavslarni ochish qoidasi

Ko'paytirishning qo'shish va ayirishga nisbatan taqsimot qonunini  $(a + b) \cdot c$  va  $(a - b) \cdot c$  larni ifodalarga qo'llab, qavslar qatnashmagan ifodalarni hosil qilamiz. Bu ishni *qavslarni ochish* deb aytamiz.

2- misol.  $4 \cdot (x + 3)$  ifodadagi qavsni ochsak:

$$4 \cdot (x + 3) = 4 \cdot x + 4 \cdot 3 = 4x + 12 \text{ ni hosil qilamiz.}$$

### 16.4. Umumiy ko'paytuvchini qavsdan tashqariga chiqarish qoidasi

$$(a + b) \cdot c = a \cdot c + b \cdot c \quad \text{va} \quad (a - b) \cdot c = a \cdot c - b \cdot c$$

tengliklarning chap qismidan o'ng qismiga o'tganimizda – qavs qatnashmagan ifodalarni hosil qilamiz. Bu tengliklar *qavslarni ochish* qoidasini ifodalaydi.

2-misol.  $4 \cdot (x + 3)$  ifodada qavslarni ochsak:

$$4 \cdot (x + 3) = 4 \cdot x + 4 \cdot 3 = 4x + 12 \quad \text{ni hosil qilamiz.}$$

$(a + b) \cdot c = a \cdot c + b \cdot c$  va  $(a - b) \cdot c = a \cdot c - b \cdot c$  tengliklarning chap va o'ng qismidagi ifodalarning o'rnini almashtiramiz. Natijada

$$a \cdot c + b \cdot c = (a + b) \cdot c \quad \text{va} \quad a \cdot c - b \cdot c = (a - b) \cdot c$$

tengliklarni hosil qilamiz.

Bu tengliklar *umumiy ko'paytuvchini qavsdan tashqariga chiqarish* qoidasini ifodalaydi.

3- misol.  $5x + 2x$  ifodada umumiy ko'paytuvchi  $x$  ni qavsdan tashqariga chiqarsak:

$$5x + 2x = (5 + 2)x = 7x \quad \text{hosil bo'ladi.}$$

Shunga o'xshash umumiy ko'paytuvchini qavsdan tashqariga chiqarishga doir quyidagi misollarni ham keltirish mumkin:

4- misol. a)  $38 \cdot 7 + 12 \cdot 7 = (38 + 12) \cdot 7 = 50 \cdot 7 = 350$ ;

b)  $29 \cdot 7 - 19 \cdot 7 = (29 - 19) \cdot 7 = 10 \cdot 7 = 70$ ;

d)  $13 \cdot 8 + 14 \cdot 18 + 17 \cdot 8 - 14 \cdot 8 = (13 + 17) \cdot 8 + 14(18 - 8) = 30 \cdot 8 + 14 \cdot 10 = 240 + 140 = 380$ .

Ifodalarni ixchamlash tenglamalarni yechishni osonlashtiradi.

5- misol. Tenglamani yeching:  $8x + 3x + 21 = 43$ .

*Yechish:*  $8x + 3x = 11x$  bo'lgani uchun tenglamani quyidagicha yozib olish mumkin:  $11x + 21 = 43$ .

Undan  $11x = 43 - 21$  yoki  $11x = 22$  tenglamaga kelamiz.

Uni yechib,  $x = 22 : 11$  yoki  $x = 2$  ekanligini topamiz.

Shuningdek, ifodalarni soddalashtirishda ko'paytirishning guruhlash xossasidan ham foydalaniladi.

Masalan,  $2x \cdot 5 \cdot 6$  ifodani  $(2 \cdot 5 \cdot 6)x$  yoki  $60x$  deb yozish mumkin.

$8x + 3x + 21 = 43,$
$11x + 21 = 43,$
$11x = 43 - 21,$
$11x = 22,$
$x = 22 : 11,$
$x = 2.$

## 16.5. Masalalar yechishda ifodalarni soddalashtirish usullaridan foydalanish

Matnli masalalarni tenglama tuzib yechishda ham ifodalarni soddalashtirish usullaridan keng foydalaniladi. Buni quyidagi masalalarni yechishda ko'rish mumkin:

**6- misol.** Ikki kunda 220 kg qulupnay terildi. Ikkinchi kun birinchi kunga qaraganda 3 marta ko'p qulupnay terildi. Birinchi kuni qancha qulupnay terilgan?

**Yechish:** Birinchi kun terilgan qulupnay massasini  $x$  bilan belgilaymiz. Unda masala shartiga ko'ra, ikkinchi kuni terilgan qulupnay massasi  $3x$  ga teng bo'ladi va ularning yig'indisi 220 ga teng bo'ladi.

Demak,  $x + 3x = 220$  tenglamaga ega bo'lamiz.

Uni yechamiz:  $4x = 220$ ,  $x = 220 : 4$ ,  $x = 55$ .

**Javob:** 1- kuni 55 kg qulupnay terilgan.

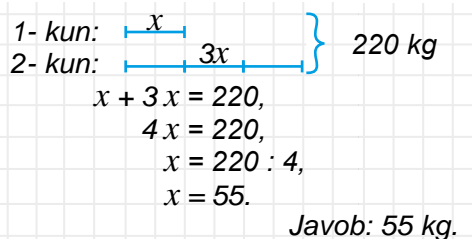

$$\begin{aligned}
 & \left. \begin{array}{l} 1\text{- kun: } x \\ 2\text{- kun: } 3x \end{array} \right\} 220 \text{ kg} \\
 & x + 3x = 220, \\
 & 4x = 220, \\
 & x = 220 : 4, \\
 & x = 55.
 \end{aligned}$$

**Javob:** 55 kg.

**7- misol.** 2 hissa sariq va 3 hissa ko'k bo'yoqlar aralashtirilib, yashil rangli bo'yoq tayyorlandi. 1500 g yashil rangli bo'yoq tayyorlash uchun qancha sariq rangli bo'yoq kerak bo'ladi?

**Yechish:** Bir hissa bo'yoq massasini  $x$  bilan belgilaymiz. Unda masala shartiga ko'ra, yashil rangli bo'yoq tarkibidagi sariq rangli bo'yoq massasi  $2x$ , ko'k rangli bo'yoq massasi  $3x$  ga teng bo'lib, ularning yig'indisi 1500 ga teng bo'ladi.

Demak,  $2x + 3x = 1500$  tenglamaga ega bo'lamiz.

Uni yechamiz:  $5x = 1500$ ,  $x = 1500 : 5$ ,  $x = 300$ .

Unda, sariq rang massasi  $2x = 2 \cdot 300 = 600$  (g) bo'ladi.

**Javob:** Sariq rangdan 600 g kerak bo'ladi.

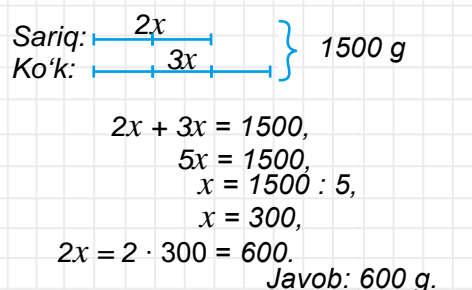

$$\begin{aligned}
 & \left. \begin{array}{l} \text{Sariq: } 2x \\ \text{Ko'k: } 3x \end{array} \right\} 1500 \text{ g} \\
 & 2x + 3x = 1500, \\
 & 5x = 1500, \\
 & x = 1500 : 5, \\
 & x = 300, \\
 & 2x = 2 \cdot 300 = 600.
 \end{aligned}$$

**Javob:** 600 g.

### Savollarga javob bering!



1. Ko'paytirishning qo'shishga nisbatan taqsimot qonunini misollarda tushuntiring.
2.  $(a - b) \cdot c = a \cdot c - b \cdot c$  yozuv qaysi qonunni ifodalaydi?
3. Umumiy ko'paytuvchini qavsdan tashqariga chiqarishni misollarda tushuntiring.
4.  $(a + b) \cdot c$  ifodada qavslarni ochish uchun qaysi qonundan foydalanish kerak?



### Sinfda bajariladigan mashqlar

- 349.** Qaysi hisoblash usuli qulay:  
 a)  $(100 + 40) \cdot 9 = 140 \cdot 9 = \dots$  yoki  $(100 + 40) \cdot 9 = 100 \cdot 9 + 40 \cdot 9 = \dots$ ?  
 b)  $8 \cdot (40 - 1) = 8 \cdot 39 = \dots$  yoki  $8 \cdot (40 - 1) = 8 \cdot 40 - 8 \cdot 1 = \dots$ ?

**350.** Hisoblang:

- a)  $7 \cdot (10 + 4)$ ;                      b)  $9 \cdot (100 + 10)$ ;                      d)  $8 \cdot (90 + 1)$ ;  
 e)  $4 \cdot (30 + 100)$ ;                      f)  $6 \cdot (20 + 7)$ ;                      g)  $5 \cdot (100 - 3)$ .

**351.** Ko'paytirishning taqsimot xossalaridan foydalanib, ko'paytmani qulay usulda hisoblang:

- a)  $51 \cdot 7$ ;                      b)  $299 \cdot 4$ ;                      d)  $24 \cdot 11$ ;  
 e)  $3 \cdot 71$ ;                      f)  $4 \cdot 701$ ;                      g)  $505 \cdot 6$ .

*Namuna:* a)  $51 \cdot 7 = (50 + 1) \cdot 7 = 50 \cdot 7 + 1 \cdot 7 = 350 + 7 = 357$ .

**352.** Biror sonni 15 ga ko'paytirishni oson bajarsa ham bo'ladi. Buning uchun bu sonni 10 ga ko'paytirib, ko'paytmaga hosil bo'lgan sonning yarmini qo'shib qo'yish kifoya:

$$34 \cdot 15 = 34 \cdot (10 + 5) = 34 \cdot 10 + 34 \cdot 5 = 340 + 170 = 510.$$

Bu usuldan foydalanib quyidagi ko'paytmalarni hisoblang:

- a)  $66 \cdot 15$ ;                      b)  $160 \cdot 15$ ;                      d)  $42 \cdot 15$ ;                      e)  $640 \cdot 15$ .

**353.** Qavslarni oching:

- a)  $5 \cdot (x + 3)$ ;                      b)  $(6 + x) \cdot 2$ ;                      d)  $4 \cdot (x - 8)$ ;  
 e)  $(y - 7) \cdot 3$ ;                      f)  $12 \cdot (c + 8)$ ;                      g)  $(4 - y) \cdot 5$ .

**354.** Ifodani soddalashtirib uning qiymatini toping:

- a)  $23a + 13a$ , bunda  $a = 9$ ;                      b)  $34b - 17b$ , bunda  $b = 19$ .

**355.** Uch xonali sonni 1001 ga ko'paytirish uchun uning yoniga yana shu sonning o'zini yozish kifoya. Bu qoidani a)  $321 \cdot 1001$ ; b)  $478 \cdot 1001$ ; d)  $905 \cdot 1001$  misollarda tekshirib ko'ring va uning to'g'riligini asoslang.

*Namuna:*  $639 \cdot 1001 = 639 \cdot (1000 + 1) = 639\,000 + 639 = 639\,639$ .



**356.** Ifodadagi umumiy ko'paytuvchini qavsdan tashqariga chiqarib, uning qiymatini toping:

- a)  $81 \cdot 21 + 19 \cdot 21$ ;                      b)  $252 \cdot 80 - 252 \cdot 70$ ;                      d)  $201 \cdot 91 + 112 \cdot 91$ ;  
 e)  $696 \cdot 24 - 696 \cdot 14$ ;                      f)  $53 \cdot 17 + 32 \cdot 17$ ;                      g)  $23 \cdot 99 - 23 \cdot 51$ .

*Namuna:* a)  $81 \cdot 21 + 19 \cdot 21 = (81 + 19) \cdot 21 = 100 \cdot 21 = 2100$ .

**357.** Ifodadagi umumiy ko'paytuvchini qavsdan tashqariga chiqarib, uni ko'paytma ko'rinishida ifodalang:

- a)  $15x + 34x$ ;                      b)  $49x - 24x$ ;                      d)  $100x - x$ ;  
 e)  $89b - 39b$ ;                      f)  $999x + x$ ;                      g)  $597p - 197p$ .

*Namuna:* a)  $15x + 34x = (15 + 34) \cdot x = 49x$ .

**358.** Ifodaning qiymatini toping:

a)  $72a + 32b$ , bunda  $a = 9$  va  $b = 12$ ;

b)  $77p + 45q$ , bunda  $p = 23$  va  $q = 51$ .

**359.** a) 54; b) 31; d) 86 sonini 101 ga ko'paytiring. Natijalar asosida ikki xonali sonni 101 ga og'zaki ko'paytirish qoidasini yozing va asoslang.

*Namuna:*  $63 \cdot 101 = 63 \cdot (100 + 1) = 63 \cdot 100 + 63 = 6300 + 63 = 6363$ .

**360.** Agar to'g'ri to'rtburchakning perimetri 390 sm bo'lsa, 2- rasmdagi ma'lumotlardan foydalanib uning tomonlarini toping.

**361.** Ifodani soddalashtiring:

a)  $5x + 23 + 4x + 1$ ;

b)  $12y + 31 + 34y + 8$ ;

d)  $72 + 23p + 30 + 44p + 1$ ;

e)  $55d + 23 + 45 + 45d$ .



**362.** Tenglamani yeching:

a)  $3x + 4x + 17 = 24$ ;

b)  $8y + 56 + 4y = 80$ ;

d)  $11p - 4p - 25 = 24$ ;

e)  $18d + 5d - 23 = 23$ .

**363.** Ikki kunda 2350 kg kartoshka terildi. Ikkinchi kun birinchi kunga qaraganda 4 marta ko'p kartoshka terildi. Birinchi kun qancha kartoshka terilgan?

*Namuna:* Yuqorida ko'rilgan 6- misol.

**364.** 3-rasmdagi qaysi holda arzon xarid amalga oshiriladi?

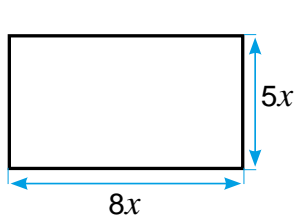

2- rasm

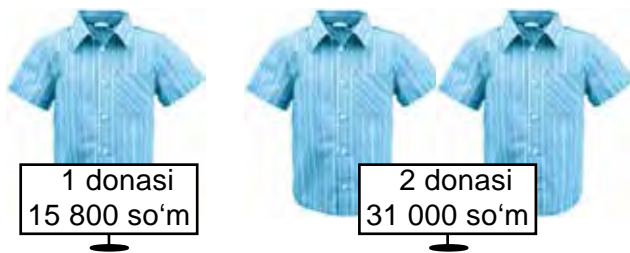

3- rasm

**365.** 5 hissa suvga 2 hissa tuz qo'shib aralashma hosil qilindi. 14 kg aralashma hosil qilish uchun qancha tuz kerak bo'ladi?

*Namuna:* Yuqorida ko'rilgan 7- misol.

**366.** Muzqaymoqning 7 qismi sut, 2 qismi sariyog' va 2 qismi shakardan iborat. 1 kg 210 g muzqaymoq tayyorlash uchun qancha sut kerak bo'ladi?

**367.** 7 qatorning har biriga 24 tadan pomidor ko'chati ekildi. So'ng bu qatorlarning har biriga yana 8 tadan qo'shimcha ko'chat ekildi. Jami necha tup ko'chat ekilgan?

**368.** Saodat bir son o'yladi. Uni oldin 15 ga ko'paytirdi, song uni alohida yana 45 ga ko'paytirdi. Natijalarni qo'shganda 1500 hosil bo'ldi. Saodat qaysi sonni o'ylagan?



Uyda bajariladigan mashqlar

- 369.** Ko'paytirishning taqsimot xossalariidan foydalanib, ko'paytmani qulay usulda hisoblang:  
 a)  $71 \cdot 9$ ;    b)  $39 \cdot 9$ ;    d)  $15 \cdot 61$ ;    e)  $5 \cdot 52$ ;    f)  $3 \cdot 901$ ;    g)  $701 \cdot 12$ .
- 370.** Qavslarni oching:  
 a)  $9 \cdot (5x + 2)$ ;                      b)  $7 \cdot (9x - 11)$ ;                      d)  $5 \cdot (7c + 3)$ ;  
 e)  $(10 + 7x) \cdot 6$ ;                      f)  $(3y - 5) \cdot 3$ ;                      g)  $(9 - 5y) \cdot 8$ .
- 371.** Ifodaning qiymatini toping:  
 a)  $12a + 51b$ , bunda  $a = 11$  va  $b = 23$ ;    b)  $59p - 23q$ , bunda  $p = 13$  va  $q = 22$ .
- 372.** Sonni 5 ga ko'paytirish uchun uning o'ng tomoniga bitta nol qo'yish va hosil bo'lgan sonni 2 ga bo'lish kifoya. Haqiqatan ham, buni quyidagi misolda ham ko'rish mumkin:

$$528 \cdot 5 = 528 \cdot (10 : 2) = (528 \cdot 10) : 2 = 5280 : 2 = 2640.$$

Bu qoidadan foydalanib, ko'paytmani hisoblang:

- a)  $248 \cdot 5$ ;    b)  $374 \cdot 5$ ;    d)  $213\ 124 \cdot 5$ ;    e)  $8\ 746\ 307 \cdot 5$ ;    f)  $130\ 379 \cdot 5$ .

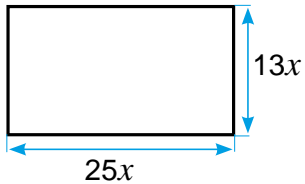

- 373.** Ifodadagi umumiy ko'paytuvchini qavsdan tashqariga chiqarib, uning qiymatini toping:  
 a)  $76 \cdot 29 + 14 \cdot 29$ ;                      d)  $37 \cdot 13 + 28 \cdot 77 + 63 \cdot 13 - 18 \cdot 77$ ;  
 b)  $678 \cdot 88 + 678 \cdot 12$ ;                      e)  $261 \cdot 12 + 29 \cdot 101 + 60 \cdot 12 - 17 \cdot 101$ .
- 374.** Ko'paytma ko'rinishida ifodalang:  
 a)  $76x + 55x$ ;                      d)  $98x - 65x$ ;                      f)  $1000p - p$ ;  
 b)  $13y + 65y$ ;                      e)  $43b - 32b$ ;                      g)  $999n + n$ .
- 375.** Agar to'g'ri to'rtburchakning perimetri 4712 mm bo'lsa, 4- rasmdagi ma'lumotlardan foydalanib, uning tomonlarini toping.
- 

4- rasm
- 376.** Ifodani soddalashtiring:  
 a)  $7x + 43 + 6x + 15$                       b)  $65y + 30 + 35y + 8$ ;  
 d)  $109 + 49p + 28 + 71p$ ;                      e)  $128d + 523 + 477 + 120d$ .



- 377.** Tenglamani yeching:  
 a)  $21x + 16x + 55 = 166$ ;                      b)  $81y + 60 + 9y = 960$ ;  
 d)  $59p - 19p + 125 = 565$ ;                      e)  $58d + 37d + 212 = 972$ .
- 378.** Bug'doy tegirmonda yanchilganda 6 hissa un va 2 hissa kepak hosil bo'ladi. 560 tonna bug'doydan qancha un olinadi?
- 379.** Shisha tayyorlash uchun 25 qism qum, 9 qism soda va 5 qism ohak ishlatiladi. 7 kg 800 g shisha tayyorlash uchun qancha qum kerak bo'ladi?
- 380.** Ishchi 1 soatda 17 ta detal, shogirdi esa 12 ta detal tayyorlaydi. Ular 7 soat davomida birgalikda qancha detal tayyorlashadi?



17- §.

**NATURAL SONLAR USTIDA TO'RT AMALGA DOIR MASALALAR YECHISH. AMALLARNI BAJARISH TARTIBI**

**17.1. Amallarni bajarish tartibi**

Qo'shish va ayirish – I bosqich, ko'paytirish va bo'lish esa – II bosqich amallari deb yuritiladi.

Ifodalarning qiymatini topishda amallarni bajarish tartibi quyidagi qoidalar asosida aniqlanadi:

*1- qoida.* Agar ifodada qavslar bo'lmasdan, faqat bitta bosqich amallari qatnashsa, amallar chapdan o'ngga qarab yozilish tartibida ketma-ket bajariladi.

*1- misol.*  $762 - 413 + 381 - 256$  ifodaning qiymatini toping.

*Yechish.* Bu ifodada qavslar yo'q va faqat I bosqich amallari qatnashyapti. Demak, 1-qoidaga ko'ra amallarni chapdan o'ngga yozilish tartibida ketma-ket bajaramiz. Amallarni bajarish tartib raqami amallar ustiga yozilgan:

$$\begin{array}{ccccccc} \textcircled{1} & \textcircled{2} & \textcircled{3} & & \textcircled{2} & \textcircled{3} & \textcircled{3} \\ 762 - 413 + 381 - 256 = & \underline{349} + 381 - 256 = & \underline{730} - 256 = & 474. \end{array}$$

*Javob:* Ifodaning qiymati 474 ga teng.

*2- misol.*  $640 : 32 \cdot 56 : 28$  ifodaning qiymatini toping.

*Yechish.* Ifodada qavs yo'q va unda faqat II bosqich amallari qatnashyapti. Demak, 1- qoidaga ko'ra, amallar chapdan o'ngga yozilish tartibida ketma-ket bajariladi. Amallarni bajarish tartib raqami amallar ustiga yozilgan:

$$\begin{array}{ccccccc} \textcircled{1} & \textcircled{2} & \textcircled{3} & & \textcircled{2} & \textcircled{3} & \textcircled{3} \\ 640 : 32 \cdot 56 : 28 = & \underline{20} \cdot 56 : 28 = & \underline{1120} : 28 = & 40. \end{array}$$

*Javob:* Ifodaning qiymati 40 ga teng.

*2- qoida.* Agar ifodada qavslar bo'lmasdan, har ikkala bosqich amallari ham qatnashsa, oldin II bosqich amallari, so'ng I bosqich amallari bajariladi.

*3- misol.*  $239 - 24 : 8 + 32 \cdot 7$  ifodaning qiymatini toping.

*Yechish.* Ifodada qavs yo'q va har ikkala bosqich amallari ishtirok etyapti. Demak, 2- qoidaga ko'ra oldin II bosqich amallarini, so'ng I bosqich amallarini bajaramiz. Amallarni bajarish tartib raqami amallar ustiga yozilgan:

$$\begin{array}{ccccccc} \textcircled{3} & \textcircled{1} & \textcircled{4} & \textcircled{2} & & \textcircled{3} & \textcircled{4} & \textcircled{4} \\ 239 - 24 : 8 + 32 \cdot 7 = & \underline{239} - 3 + 224 = & \underline{236} + 224 = & 460. \end{array}$$

*Javob:* Ifodaning qiymati 460 ga teng.

*3- qoida.* Agar ifodada qavslar qatnashgan bo'lsa, oldin qavslar ichidagi amallar, so'ng boshqa amallar 1- va 2- qoidalarga ko'ra bajariladi.

**4- misol.**  $(1216 + 16 \cdot 9) : 4 - 1440 : 12$  ifodaning qiymatini toping.

**Yechish.** Bu ifodada qavslar qatnashyapti. Demak, 3- qoidaga ko'ra oldin qavs ichidagi amallarni bajarimiz. So'ng esa 2- qoidaga ko'ra hisoblashlarni davom ettiramiz. Amallarni bajarish tartib raqami amallar ustiga yozilgan:

$$\begin{aligned} & \overset{\textcircled{2}}{(1216 + 16 \cdot 9)} : 4 - 1440 : 12 = \overset{\textcircled{2}}{(1216 + 144)} : 4 - 1440 : 12 = \\ & \qquad \qquad \qquad \overset{\textcircled{3}}{=} 1360 : 4 - 1440 : 12 = \overset{\textcircled{4}}{=} 340 - 120 = \overset{\textcircled{5}}{=} 220. \end{aligned}$$

**Javob:** Ifodaning qiymati 220 ga teng.

## 17.2. Qavslarni tashlab yuborish

Agar ifodadagi qavslarni tashlab yuborish amallarning bajarilish tartibiga ta'sir qilmasa, unda qavslarni tashlab yuborish mumkin. Masalan,  $(49 + 23) - 39$  ifodadagi qavslarni tashlab yuborib,  $49 + 23 - 39$  ko'rinishda yozish mumkin, chunki bu amallarni bajarish tartibiga ta'sir qilmaydi.

Ifodalarning qiymatini hisoblayotganda qo'shish, ayirish va ko'paytirish amallarining xossalariidan foydalanish maqsadga muvofiq bo'lsa, amallarni bajarish tartibi qoidalaridan chetga chiqish ham mumkin.

Masalan,  $37 \cdot 8 + 13 \cdot 8$  ifodaning qiymatini 2- qoidaga asosan hisoblagandan ko'ra, ko'paytirishning qo'shishga nisbatan taqsimot qonunidan foydalanib hisoblagan ma'qul:  $37 \cdot 8 + 13 \cdot 8 = (37 + 13) \cdot 8 = 50 \cdot 8 = 400$ .



### Savollarga javob bering!

1. I va II bosqich amallarini ayting.
2. Faqat bitta bosqich amallari qatnashgan, qavssiz ifodada amallar qay tartibda bajariladi?
3. Har ikkala bosqich amallari qatnashgan, qavssiz ifodada amallar qaysi tartibda bajariladi?
4. Qavs qatnashgan ifodada oldin qaysi amallar bajariladi?



### Sinfda bajariladigan mashqlar

**381.** Ifodadagi amallarni bajarish tartibini aniqlang va uning qiymatini toping:

- |  |   |
|--|---|
| a) $78 - 45 + 54 - 49$ ;               | b) $231 + 112 - 223 - 109$ ;                  |
| d) $721 : 7 - 112 : 8 + 37 \cdot 22$ ; | e) $322 : 23 \cdot 22 - 483 \cdot 9 : 23$ ;   |
| f) $315 : (375 - 24 \cdot 15) + 98$ ;  | g) $(24 \cdot 7 - 676 : 13) \cdot 13 - 238$ . |

**Namuna:** Yuqorida ko'rilgan 1-, 2-, 3-, 4- misollar.

**382.** Hisoblang:

- a)  $(56 - 56) : 342 + (289 - 288) \cdot 122$ ; b)  $(56 + 46) \cdot 23 + (444 - 443) \cdot 34$ .

**383.** Ifodaning qiymatini toping:

- |  |  |
|--|--|
| a) $132 + 129 - 237 + 97$ ;                          | b) $764 - 348 - 112 + 231$ ;                         |
| d) $945 : 45 \cdot 22 \cdot 12$ ;                    | e) $24 \cdot 12 \cdot 25 : 100$ ;                    |
| f) $23 \cdot 12 + 490 : 14 - 224 : 16$ ;             | g) $321 \cdot 12 : 69 + 644 : 23 - 93$ ;             |
| h) $831 + 5865 : (22 \cdot 29 - 13 \cdot 19) - 87$ ; | i) $(3915 : 87 + 867) - (18 \cdot 15 - 1305 : 29)$ . |



**384.** Qo'shish va ayirish xossalari ta'yanlangan holda ifodaning qiymatini qulay usulda hisoblang:

- |                                  |                             |                                     |
|----------------------------------|-----------------------------|-------------------------------------|
| a) $1278 + 432 + 568$ ;          | b) $123 \cdot 4 \cdot 25$ ; | d) $2132 + 231 - 132$ ;             |
| e) $32 \cdot 17 + 68 \cdot 17$ ; | f) $708 - 342 - 208$ ;      | g) $786 \cdot 115 - 86 \cdot 115$ . |

**385.**  $37 + 5 \cdot 7 - 3$  ifodaga qavslarni ma'noga ega bo'lgan hamma joylarga qo'ying va hosil bo'lgan har bir ifodaning qiymatini toping.

**386.** Ifoda tuzing va uning qiymatini toping:

- a)  $24 \cdot 11$  ko'paytma va  $96 : 3$  bo'linmaning yig'indisi;  
 b) 510 sonidan  $236 + 128$  yig'indining ayirmasi;  
 d)  $27 + 3$  yig'indining  $52 - 22$  ayirmaga ko'paytmasi;  
 e)  $31 + 29$  yig'indining 30 soniga bo'linmasi.



**387.** Hisoblang:

- a)  $97 + 13\ 662 : 27 + 36\ 944 - 43 \cdot 809$ ;  
 b)  $988 + 1530 : (12 \cdot 6 - 38) \cdot 15$ ;  
 d)  $4080 - (35\ 2719 - 57\ 837) : 98 + 307 \cdot 107$ ;  
 e)  $40 \cdot (207 \cdot 54 - 793) - 270\ 000 : 18$ ;  
 f)  $215 \cdot (368 - 274) + 68 \cdot (127 + 128)$ ;  
 g)  $(8222 - 4781) : 37 - (1519 - 637) : 42$ .

**388.** Amallarni bajaring:

- |                                   |                                       |
|-----------------------------------|---------------------------------------|
| a) $703 - 21 \cdot (361 - 349)$ ; | b) $23\ 460 : (209 - 186) \cdot 15$ ; |
| d) $6422 - 24 \cdot (372 : 12)$ ; | e) $2678 : (506 - 480) + 297$ ;       |
| f) $77 \cdot (452 - 348) - 99$ ;  | g) $874 - (27 \cdot 90 - 1999)$ ;     |
| h) $(1593 : 27 + 326) \cdot 60$ ; | i) $6720 : 12 \cdot 35 - 898$ .       |

**389.** Ifodaning qiymatini toping:

- a)  $(410 + 96) \cdot (1010 - 31\ 248 : 62) - 170 \cdot 1500$ ;  
 b)  $(174\ 208 - 208 \cdot (563 + 44)) : 333 + 2079 : 77$ ;  
 d)  $(18 \cdot 331 - (46\ 348 + 67\ 892) : 21) : 14 + 143 \cdot 26$ ;  
 e)  $(201 \cdot (400\ 100 - 397\ 964) + 5392) : 24 - 8154$ ;  
 f)  $(7470 : 18 - 319) + (2060 - 24 \cdot 45) : 28$ .



**390.** Ifodani soddalashtiring:

- |                            |                              |
|----------------------------|------------------------------|
| a) $2a + 612 + 7a + 324$ ; | b) $12y + 29y + 781 + 219$ ; |
|----------------------------|------------------------------|

**391.** Avtomobil 240 km yo'lni 4 soatda bosib o'tishi kerak edi. Lekin avtomobil tezligi 20 km/soat ga oshirildi. Avtomobil manzilga qancha vaqt oldin yetib keladi?

- 392.** Ali, Soli va Vali tarozida o'z vaznlarini o'lchashdi. Ma'lum bo'lishicha, Ali bilan Solining vazni birgalikda 57 kg, Soli bilan Valining vazni 56 kg, Ali va Valining vazni 61 kg ekan. Har bir bolaning vazni qancha ekanligini toping.



### Uyda bajariladigan mashqlar

- 393.** Ifodada amallarni bajarish tartibini aniqlang, so'ng uning qiymatini toping:  
 a)  $123 - 67 + 231 - 224$ ;                      b)  $445 + 333 - 369 - 206$ ;  
 d)  $824 : (399 - 23 \cdot 17) + 98$ ;              e)  $(52 \cdot 9 - 1035 : 45) \cdot 7 - 122$ .
- 394.** Ifodaning qiymatini toping:  
 a)  $77 - 45 + 37 - 23$ ;  
 b)  $456 + 123 - 239 - 33$ ;  
 d)  $(31 \cdot 9 - 754 : 29) \cdot (1323 : 27 - 31)$ ;  
 e)  $(186 + 59 \cdot 6) : (19 \cdot 35 - 17 \cdot 37) - 12$ .
- 395.** Qo'shish va ayirish xossalariga tayangan holda amallarning bajarilish tartibini o'zgartiring va qulay usulda ifodaning qiymatini hisoblang:  
 a)  $56 + 88 + 44$ ;                      b)  $224 \cdot 4 \cdot 250$ ;                      d)  $13245 + 8899 - 3245$ ;  
 e)  $87 \cdot 33 + 13 \cdot 33$ ;                      f)  $1555 - 234 - 766$ ;                      g)  $1199 \cdot 678 - 199 \cdot 678$ .



- 396.** Ifodani soddalashtiring:  
 a)  $11a + 43 + 76a + 27$ ;                      b)  $332y + 211y + 999 + 677$ ;  
 d)  $234 + 35a + 725 + 16a$ ;                      e)  $781 - 455 + 37n + 39n$ .
- 397.** Ifodaning qiymatini toping:  
 a)  $66 \cdot 24 : 22 + 17017 : 17$ ;                      b)  $(42 \cdot 25 - 36) : 39 + (800 : 40 - 18) \cdot 12$ .  
 d)  $9 \cdot (1030 - 579) + 941$ ;                      e)  $8000 - (398 + 132) \cdot 15$ ;  
 f)  $(770 - 669) \cdot (546 - 489)$ ;                      g)  $136 \cdot (668 - 588) - 404 \cdot 25$ ;  
 h)  $1540 : 11 + 1890 : 9 + 982$ ;                      i)  $1953 + (17432 - 56 \cdot 223) : 16$ .

- 398.** Tenglamani yeching:  
 a)  $3x + 5x + 96 = 1568$ ;                      b)  $2y + 7y + 78 = 1581$ ;  
 d)  $88880 : 110 + x = 809$ ;                      e)  $357y - 149y - 1843 = 11469$ ;  
 f)  $256m - 147m - 1871 = 63747$ ;                      g)  $6871 + p : 121 = 7000$ .



- 399.** Velosipedchilar birinchi kuni 154 km, ikkinchi kuni birinchi kundan 23 km ko'p, uchinchi kun esa ikkinchi kundan 13 km kam masofani bosib o'tdilar. Velosipedchilar uch kunda qancha masofa bosib o'tishgan?
- 400.** Tikuv sexida har biri 30 m dan bo'lgan 9 to'p va har biri 40 m dan bo'lgan 13 to'p mato bor edi. Bu matoning 243 metri ishlatildi. Sexda necha metr mato qoldi?
- 401.** Sayohatchi bir shahardan ikkinchisiga bormoqchi. U oldin avtomobilda 70 km/soat tezlikda 2 soat yo'l bosdi. So'ng piyoda 4 soat 5 km/soat tezlik bilan yurdi. Shunda ikkinchi shahargacha yana 14 km yo'l qoldi. Bu shaharlar orasidagi masofa qancha?

**18- §.**

**SONNING DARAJASI. SONNING KVADRATI VA KUBI**

Bir-biriga teng ko'paytuvchilar ko'paytmasi maxsus belgilash orqali qisqaroq yoziladi, ya'ni  $3 \cdot 3 \cdot 3 \cdot 3 \cdot 3$  o'rniga  $3^5$  kabi yoziladi va «3 ning 5- darajasi» deb o'qiladi.

Bu yozuvda 3 – daraja asosi, 5 – daraja ko'rsatkichi deb ataladi.  $3^5$  ifodaning o'zi esa daraja deb yuritiladi.

Quyidagi misollarda ko'paytma daraja ko'rinishida yozilgan:

a)  $2 \cdot 2 \cdot 2 \cdot 2 = 2^4 = 16$ ; b)  $5 \cdot 5 \cdot 5 = 5^3 = 125$ ; c)  $3 \cdot 3 \cdot 3 \cdot 3 \cdot 3 = 3^5 = 243$ .

Sonning ikkinchi va uchinchi darajasi maxsus nomlar bilan ataladi.

$3 \cdot 3$  ko'paytma 3 ning kvadrati deyiladi va  $3^2$  tarzida belgilanadi.

$4 \cdot 4 \cdot 4$  ko'paytma 4 ning kubi deb ataladi va  $4^3$  tarzida belgilanadi.

$a$  ning  $a$  ga ko'paytmasi  $a$  sonining kvadrati deb ataladi va  $a^2$  ko'rinishida belgilanadi.

Demak,  $a^2 = a \cdot a$ .

$a^2$  yozuv «a ning kvadrati» yoki «a kvadrat» deb o'qiladi.

Masalan,  $12^2 = 12 \cdot 12 = 144$ .

$a \cdot a \cdot a$  ko'paytmaga  $a$  sonining kubi deb ataladi va  $a^3$  ko'rinishida belgilanadi.

Demak,  $a^3 = a \cdot a \cdot a$ .

$a^3$  yozuv «a ning kubi» yoki «a kub» deb o'qiladi.

Masalan,  $6^3 = 6 \cdot 6 \cdot 6 = 216$ .

Quyida 1 dan 10 gacha bo'lgan natural sonlar kvadrati jadvali berilgan:

$n$	1	2	3	4	5	6	7	8	9	10
$n^2$	1	4	9	16	25	36	49	64	81	100

Quyida 1 dan 10 gacha bo'lgan natural sonlar kubi jadvali berilgan:

$n$	1	2	3	4	5	6	7	8	9	10
$n^3$	1	8	27	64	125	216	343	512	729	1000

Sonning birinchi darajasi shu sonning o'ziga teng deb olinadi:  $8^1 = 8, 13^1 = 13, 1^1 = 1$ . Odatda, 1- daraja ko'rsatkichi yozilmaydi.

Agar ifodada darajalar ham qatnashgan bo'lsa, oldin darajalar qiymatlari topiladi. So'ng boshqa amallarni bajarishga kirishiladi.

**1- misol.**  $(6^3 + 13) \cdot 2 - 2^4 \cdot 3^2$  ifodaning qiymatini toping.

**Yechish.** Amallar quyidagi tartibda bajariladi:

$$\textcircled{1} \textcircled{4} \quad \textcircled{5} \quad \textcircled{7} \textcircled{2} \textcircled{6} \textcircled{3}$$

$$(6^3 + 13) \cdot 2 - 2^4 \cdot 3^2$$

Oldin darajalarni hisoblaymiz:  $6^3 = 216, 2^4 = 16, 3^2 = 9$ .

Ularni ifodaga qo'yamiz va hisoblashni davom ettiramiz:

$$(216 + 13) \cdot 2 - 16 \cdot 9 = 229 \cdot 2 - 16 \cdot 9 = 458 - 144 = 314.$$

**Javob:** Ifodaning qiymati 314 ga teng.



### Savollarga javob bering!

1. Sonning: a) kvadrati; b) kubi deb nimaga aytiladi?
2. Daraja, daraja ko'rsatkichi, daraja asosi atamalarini biror misolda tushuntiring.
3. Natural sonning birinchi darajasi nimaga teng bo'ladi?



### Sinfda bajariladigan mashqlar

**402.** Daraja ko'rinishida yozing:

- a)  $8 \cdot 8 \cdot 8 \cdot 8 \cdot 8 \cdot 8 \cdot 8$ ;      b)  $24 \cdot 24 \cdot 24 \cdot 24$ ;      d)  $x \cdot x \cdot x \cdot x \cdot x$ ;  
 e)  $5 \cdot 5 \cdot 5 \cdot 5 \cdot 5$       f)  $13 \cdot 13 \cdot 13 \cdot 13$ ;      g)  $m \cdot m \cdot m \cdot m$ .  
 h)  $(x + 3) \cdot (x + 3) \cdot (x + 3) \cdot (x + 3)$ ;      i)  $(6 - z) \cdot (6 - z) \cdot (6 - z)$ .

**403.** Hisoblang:  $2^2$ ;  $5^2$ ;  $1^5$ ;  $7^2$ ;  $6^2$ ;  $1^6$ ;  $2^4$ ;  $4^3$ ;  $10^3$ .

**404.** Hisoblang:

- a)  $3^2 \cdot 11$ ;      b)  $5 + 6^2$ ;      d)  $(3 + 5)^2$ ;      e)  $(7^3 - 3^3) : (7 - 3)$ ;  
 f)  $(7 + 1)^3$ ;      g)  $(8 - 5)^3 : (8 - 5)$ ;      h)  $6^3 - 16$ ;      i)  $(9^2 - 2^6) : 17 + 4^2$ .

**405.** Quyidagi ifodalar qiymati tengmi?

- a)  $6^2$  va  $6 \cdot 2$ ;      b)  $3^4$  va  $3 \cdot 4$ ;      d)  $3^2$  va  $2^3$ ;      e)  $5^3$  va  $3^5$ .

**406.** Tenglamaning ildizini toping:

- a)  $x \cdot x = 36$ ;      b)  $p \cdot p = 81$ ;      d)  $y \cdot y \cdot y = 64$ ;  
 e)  $z \cdot z \cdot z \cdot z \cdot z = 1$ ;      f)  $m \cdot m \cdot m = 8$ ;      g)  $n \cdot n \cdot n \cdot n = 81$ .

*Namuna:* a)  $x \cdot x = 36$ ,       $x \cdot x = 6 \cdot 6$ ,       $x = 6$ .

**407.** Darajaning qiymatini toping: a)  $5^2$ ; b)  $10^2$ ; d)  $100^3$ ; e)  $11^3$ ; f)  $12^3$ ; g)  $15^3$ .

**408.** 11 dan 20 gacha bo'lgan sonlarning kvadratlari jadvalini tuzing.

**409.** Ifodaning qiymatini toping:

- a)  $4^2$ ;      b)  $23 + 3^2$ ;      d)  $(10^2 - 2^6) : 6 + 1^{10}$ ;      e)  $3^2 + 6^2$ ;  
 f)  $6^3 - 5^3$ ;      g)  $5^2 \cdot 2^3$ ;      h)  $(40 : 4)^5 - 100^2$ ;      i)  $(3 + 4)^2$ .



**410.** Sonning kvadrati va kubi jadvallaridan foydalanib,  $n$  ning qiymatini toping:

- a)  $n^2 = 169$ ;      b)  $n^2 = 10000$ ;      d)  $n^3 = 729$ ;      e)  $n^3 = 343$ .

**411.** Sonni 10 ning darajalari ko'rinishida yozing: 10, 100; 1000; 1 000 000; 10 000 000.

**412.** 10 ning darajalaridan foydalanib, sonni xona birliklari yig'indisi ko'rinishida yozing:

- a) 432;      b) 328;      d) 3451;      e) 20 450;      f) 213 709.

*Namuna:* a)  $432 = 400 + 30 + 2 = 4 \cdot 100 + 3 \cdot 10 + 2 \cdot 1 = 4 \cdot 10^2 + 3 \cdot 10^1 + 2 \cdot 1$ .

**413.** Hisoblang:

- a)  $2 \cdot 10^3$ ;      b)  $(2 \cdot 10)^3$ ;      d)  $3 \cdot 2^2$ ;      e)  $(3 \cdot 2)^2$ ;      f)  $12 : 2^2$ ;      g)  $(12 : 2)^2$ .

- 414.** Tenglikni tekshirib ko'ring:  
 a)  $2^3 + 2^5 + 2^6 + 2^7 + 2^8 + 2^9 = 1000$ ; b)  $11^3 + 12^3 + 13^3 + 14^3 = 8000$ ;  
 d)  $41^2 + 43^2 + 45^2 = 5555$ .
- 415.** Ifodaning qiymatini toping;  
 a)  $15^2 + 2^3 \cdot 11$ ; f)  $9^3 : (49 - 22)$ ;  
 b)  $125 + 5^3 \cdot 3$ ; g)  $2^5 \cdot (12 + 2^3)^2$ ;  
 d)  $4^3 \cdot 13 + 3^4 \cdot 12$ ; h)  $(13 \cdot 11 - 43)^3$ ;  
 e)  $1500 : 5^3 + 693 : 3^2$ ; i)  $(13 - 4 \cdot 2)^3 : (2^2 + 1)^2$ .
- 416.** Quyidagi sonning kvadrati qanday raqam bilan tugaydi?  
 a) 122; b) 923; d) 225; e) 211.

**Uyda bajariladigan mashqlar**



- 417.** Daraja ko'rinishida yozing:  
 a)  $3 \cdot 3 \cdot 3 \cdot 3 \cdot 3 \cdot 3$ ; b)  $32 \cdot 32 \cdot 32 \cdot 32 \cdot 32 \cdot 32 \cdot 32$ ;  
 d)  $d \cdot d \cdot d \cdot d \cdot d \cdot d$ ; e)  $(x + y) \cdot (x + y) \cdot (x + y) \cdot (x + y)$ .
- 418.** Hisoblang:  
 a)  $4^2 \cdot 33$ ; b)  $7 + 5^2$ ; d)  $(4+3)^3$ ; e)  $7^2 + 5^2$ ;  
 f)  $(5 + 7)^2$ ; g)  $(9 - 6)^4$ ; h)  $(40 : 8)^3 + 24$ ; i)  $(9^2 - 5^2) \cdot 5 - 35$ .
- 419.** Darajaning qiymatini toping: a)  $7^2$ ; b)  $11^2$ ; d)  $10^3$ ; e)  $16^3$ ; f)  $13^3$ ; g)  $19^3$ .
- 420.** Hisoblang:  
 a)  $5 \cdot 6^3$ ; b)  $(3 \cdot 10)^2$ ; d)  $4 \cdot 5^2$ ; e)  $(4 \cdot 5)^2$ ; f)  $3 \cdot 9 : 3^2$ ; g)  $(39 : 3)^2$ .



- 421.** Ifodaning qiymatini toping;  
 a)  $8^2 \cdot 6 + 15^2 : 5$ ; b)  $(16 - 7)^3 - 4^2$ ; d)  $5 \cdot 3^3 - 16^2 : 8$ ;  
 e)  $(3 \cdot 2)^3 - (36 : 9)^2$ ; f)  $(4 \cdot 6^2 : 2^3 + 16) \cdot 5$ ; g)  $(7^3 + 11^2 \cdot 5) - 512$ .
- 422.** Quyidagi sonning kubi qanday raqam bilan tugaydi?  
 a) 544; b) 1111; d) 5222; e) 77 777.
- 423.** Hisoblang.  
 a)  $3 \cdot 10^4 + 2 \cdot 10^3 + 7 \cdot 10^2 + 9 \cdot 10 + 4$ ;  
 b)  $6 \cdot 10^5 + 1 \cdot 10^3 + 9 \cdot 10^2 + 5$ .

**Qiziqarli matematikaga oid masalalar**



Sonli krossvordni yeching:

- Bo'yiga: a) 564 676 : 938;  
 f) 527 809 + 36 895;  
 j) 460 015 - 36296;  
 h) 411 510 : 473.
- Eniga: a) 7 003 294 - 435 926;  
 b) 40 320 : 672;  
 d) 357 992 : 4 904;  
 e) 590 \cdot 5 047.

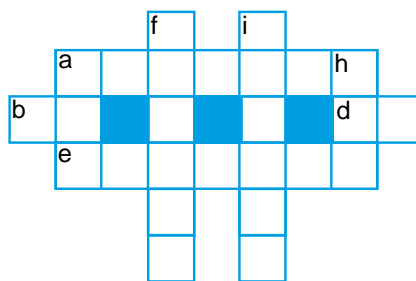

19- §.

III BOBNI TAKRORLASHGA DOIR MASALALAR

19.1. Harakatga oid masalalar yechish

Oldingi darslarda harakatga doir turli masalalarga duch keldik. Bu masalalarda odatda bir-biri bilan bog'liq uchta kattalik: *tezlik*, ya'ni vaqt birligi ichida bosib o'tilgan yo'l, *harakat vaqti* va *bosib o'tilgan yo'l* qatnashadi.

1- *misol*. A punktdan bir xil vaqtda qarama-qarshi yo'nalishda ikkita yo'lovchi yo'lga chiqdi. Birinchi yo'lovchining tezligi 6 km/soat, ikkinchisniki 4 km/soat. 2 soatdan keyin yo'lovchilar orasidagi masofa qancha bo'ladi?

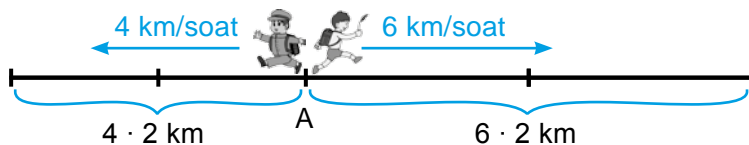

*Yechish*. 1- usul. 2 soat davomida har bir yo'lovchi bosib o'tgan yo'lni topamiz:

1- yo'lovchi:  $6 \cdot 2 = 12$  (km).      2- yo'lovchi:  $4 \cdot 2 = 8$  (km).

Demak, 2 soatdan keyin ular orasidagi masofa  $12 + 8 = 20$  (km) ga teng bo'ladi.

2- usul. Bir soatdan keyin yo'lovchilar orasidagi masofa  $4 + 6 = 10$  (km) ga teng bo'ladi.

Bu holatda yo'lovchilarning bir-biridan *uzoqlashish tezligi* 10 km/soatga teng deb aytiladi.

Demak, yo'lovchilar 2 soatdan keyin bir-biridan  $2 \cdot 10 = 20$  (km) uzoqlikda bo'lishadi.

*Javob*: 20 km.

2- *misol*. Ikki yo'lovchi bir xil vaqtda ikki punktdan bir-biriga qarab yo'lga chiqdi. Ikki punkt orasidagi masofa 27 km. Birinchi yo'lovchining tezligi 5 km/soat, ikkinchisniki esa 4 km/soat. Yo'lovchilar qancha vaqtdan keyin bir-birlari bilan uchrashishadi?

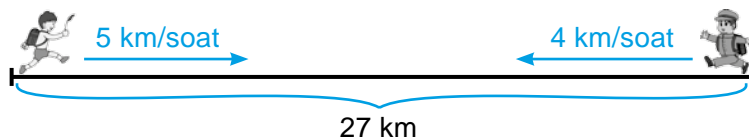

*Yechish*. Yo'lovchilarning bir-biriga *yaqinlashish tezligini* topamiz:  $5 + 4 = 9$  (km/soat).

Yo'lovchilar orasidagi masofa 27 km bo'lib, ular 1 soatda bir-biriga 9 km ga yaqinlashyapti.

Demak, yo'lovchilar  $27 : 9 = 3$  (soat) dan keyin uchrashishadi.

*Javob*: 3 soat.

19.2. Daryoda harakatlanishga doir masalalarni yechish

Daryo bo'yicha harakatga doir masalalarda *daryo oqimi bo'yicha* harakat tezligini, *daryo oqimiga qarshi* harakat tezligidan farqlash lozim bo'ladi.

Aytaylik, qayiqning o'z tezligi, ya'ni uning turg'un (oqmaydigan) suvdagi tezligi – 8 km/soat, daryo oqimining tezligi esa 2 km/soat bo'lsin.

Unda qayiqning daryo oqimi bo'yicha harakat tezligi – uning o'z tezligi va



daryo oqimi tezliklari yig'indisidan iborat bo'ladi:  $8 + 2 = 10$  (km/soat).

$$U_{\text{oqim bo'yicha}} = U_{\text{qayiq}} + U_{\text{oqim}}$$

Qayiqning daryo oqimiga qarshi harakat tezligi – uning o'z tezligi va daryo oqimi tezligi ayirmasidan iborat bo'ladi:  $8 - 2 = 6$  (km/soat).

$$U_{\text{oqimga qarshi}} = U_{\text{qayiq}} - U_{\text{oqim}}$$

**3- misol.** Kater daryo oqimi bo'yicha suzmoqda. Daryo oqimining tezligi – 3 km/soat. Agar katerning o'z (turg'un suvdagi) tezligi 18 km/soat bo'lsa, u 2 soatda qancha masofani bosib o'tadi?

**Yechish.** Kater oqim bo'yicha suzgani uchun uning harakat tezligi uning o'z tezligi va daryo oqimi tezliklari yig'indisidan iborat bo'ladi:  $18 + 3 = 21$  (km/soat).

Kater bu tezlik bilan 2 soatda  $21 \cdot 2 = 42$  (km) masofani bosib o'tadi.

**Javob:** 42 km.

### 19.3. III bobga doir masalalar yechish

**424.** Ifodaning qiymatini toping:

- a)  $210 + 210 + 210 + 210 + 4571$ ;    b)  $88 + 88 + 88 + 333 + 333 + 333$ ;  
 d)  $523 + 523 + 3278 + 523 + 3278$ ;    e)  $6530 + 153 + 153 + 6530 + 153 + 153$ .

**425.** Guruhlash qonunidan foydalanib, ko'paytmani hisoblang.

- a)  $25 \cdot (4 \cdot 7709)$ ;    b)  $(200 \cdot 13) \cdot 5$ ;    d)  $8 \cdot (125 \cdot 333)$ ;    e)  $(1010 \cdot 4) \cdot 25$ .

**426.** Qulay usul bilan hisoblang.

- a)  $40 \cdot 331 \cdot 25$ ;    b)  $424 \cdot 25 \cdot 4$ ;    d)  $8 \cdot 550 \cdot 125$ ;    e)  $50 \cdot 539 \cdot 20$ .

**427.** Agar  $a = 21$ ,  $b = 36$  bo'lsa,  $55a - 3b$  ifodaning qiymatini toping.

**428.** Ip uzunligi 14 dm dan bo'lgan 13 ta bo'lakka bo'lingan. Ipning uzunligini toping.

**429.**  $ABC$  uchburchakning  $AB$  tomoni 234 mm va u  $AC$  tomondan 5 marta qisqa. Agar uchburchak perimetri 2450 mm bo'lsa,  $BC$  tomon uzunligini toping.

**430.** Amallarni bajaring:

- a)  $24 \cdot 52 - 18 \cdot (117 - 97)$ ;    b)  $(2574 + 4333) \cdot 25 - 110 \cdot 14$ .

**431.** Avstraliya qit'asida yashaydigan kenguru 12 m uzunlikka sakrashi mumkin. Bu ajoyib hayvon 100 marta sakrasa, qancha masofani bosib o'tadu? U 1500 m masofani necha marta sakrab bosib o'tishi mumkin?

**432.** Kenguru soatiga 48 km tezlikda yugurishi mumkin. a) Kenguru 1 soatda necha metrga yugurishi mumkin? 1 minutda-chi? b) U 12 km masofani qancha vaqtda bosib o'tadi? d) U 30 sekundda qancha masofani bosib o'tadi? 5 minutda-chi?

**433.** Hisoblang. Natijani ko'paytirish orqali tekshiring:

- a)  $10\ 092 : 116$ ;    b)  $7728 : 138$ ;    d)  $9379 : 83$ ;  
 e)  $12\ 432 : 111$ ;    f)  $11\ 704 : 77$ ;    g)  $30\ 015 : 145$ .

434. Zohid kompyuterga soatiga 987 ta belgi kirita oladi. U 12 831 ta belgini matnini qancha vaqtda kirita oladi?
435. Tenglamani yeching:  
 a)  $33 \cdot x = 1386$ ;      b)  $454 \cdot a = 55\,842$ ;      d)  $x : 19 = 13$ ;  
 e)  $a : 119 = 314$ ;      f)  $26\,289 : x = 127$ ;      g)  $42\,745 : m = 415$ .
436. Qoldiqli bo'lishni bajarung:  
 a)  $983 : 18$ ;      b)  $3273 : 16$ ;      d)  $4213 : 34$ ;  
 e)  $5620 : 67$ ;      f)  $55\,337 : 134$ ;      g)  $54\,103 : 439$ .
437. Shunday sonni topingki, uni:  
 a) 17 ga bo'lganda, 88 hosil bo'lib, 11 qoldiq qolsin;  
 b) 231 ga bo'lganda, 121 hosil bo'lib, 133 qoldiq qolsin.
438. Umumiy ko'paytuvchini qavsdan tashqariga chiqarib hisoblang:  
 a)  $66 \cdot 112 + 34 \cdot 112$ ;      b)  $356 \cdot 97 - 56 \cdot 97$ ;      d)  $867 \cdot 74 + 867 \cdot 26$ ;  
 e)  $11 \cdot 54 + 89 \cdot 54$ ;      f)  $473 \cdot 164 - 473 \cdot 64$ ;      g)  $329 \cdot 251 - 129 \cdot 251$ .
439. Ikki kunda 294 yashik uzum terildi. Ikkinchi kuni birinchi kunga qaraganda 6 marta ko'p uzum terildi. Birinchi kuni qancha uzum terilgan?
440. Birinchi konveyerda 1 soatda 25 ta, ikkinchi konveyerda esa 31 ta televizor yig'iladi. Ikkala konveyerda 8 soat davomida qancha televizor yig'iladi?
441. Ifodadagi amallarni bajarish tartibini aniqlang, so'ng qiymatini toping:  
 a)  $2448 + 666 - 1291 - 1067$ ;      b)  $26 \cdot 27 : 18 \cdot 22$ ;  
 d)  $2080 : (1222 - 26 \cdot 27) + 128$ ;      e)  $(25 \cdot 19 - 1800 : 75) \cdot 11 - 221$ .
442. Ifodani soddalashtiring:  
 a)  $109d + 443 + 273d + 279$ ;      b)  $332t + 211t + 999 + 677$ ;  
 d)  $34 + 139c + 257 + 61c$ ;      e)  $1786 - 903 + 430q + 453q$ .
443. Tenglamani yeching:  
 a)  $7x + 6x + 1000 = 1975$ ;      b)  $57y - 14y - 111 = 3200$ ;  
 d)  $20838 : 453 + x = 91$ ;      e)  $875 + p : 121 = 1999$ ;  
 f)  $381 + 126 : y = 395$ ;      g)  $k + 11\,571 : 133 = 487$ .
444. Rasmdan foydalanib tenglama tuzing va noma'lumning massasini toping:

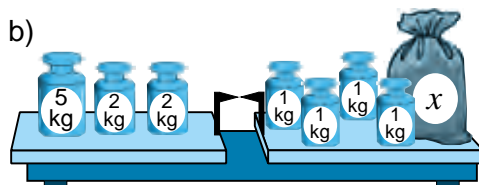
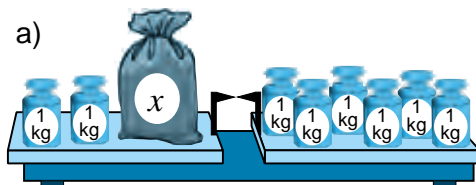

445. Hisoblang:  
 a)  $(129 - 116)^4$ ;      b)  $(11^2 - 8^2) \cdot 23 - 87$ ;      d)  $7^2 \cdot 52$ ;      e)  $(7+6)^3$ ;  
 f)  $44^2 + 33^2$ ;      g)  $(81:9)^3 + 111$ ;      h)  $(15+12)^2$ ;      i)  $8^2 + 13^2$ .
446. Ifodaning qiymatini toping:  
 a)  $1562 - 16^2 : 8$ ;      b)  $(12 + 169 : 13)^2$ ;      d)  $(127 - 77)^2 \cdot 9$ ;      e)  $11^2 \cdot (114 - 98)$ .
447. Oddiy cho'g'lanma lampaning xizmat muddati 1500 soat. Energiyani tejovchi lyuminetsent lampa esa oddiy lampaga qaraganda 7 marta uzoqroq vaqt xizmat qiladi. Energiyani tejovchi lampaning xizmat muddatini toping.

**Qiziqarli matematikaga oid masalalar**



Sonli krossvordni yeching:

- Bo'yiga: a)  $870 \cdot 706$ ;  
 h)  $100\ 000 - 43\ 535$ ;  
 j)  $1412 \cdot 435$ .

- Eniga: a)  $12 \cdot 5303$ ;  
 b)  $820\ 820 : 9020$ ;  
 d)  $143\ 412 : 7548$ ;  
 e)  $148 \cdot 159$ ;  
 f)  $50\ 381 : 83$ ;  
 g)  $460\ 312 : 652$ .

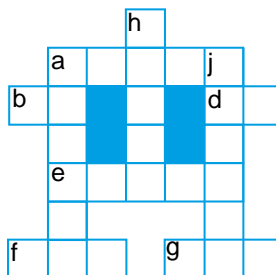

**Ulkan sonlar**

Million va milliard sonlari bilan tanishmiz. Maxsus nom bilan ataluvchi ulardan ham katta sonlar ham bor. Lekin ular juda kam ishlatiladi. Mana ularning ba'zilari:

$10^6 =$	1 000 000	million
$10^9 =$	1 000 000 000	milliard
$10^{12} =$	1 000 000 000 000	trillion
$10^{15} =$	1 000 000 000 000 000	kvadrillion
$10^{18} =$	1 000 000 000 000 000 000	kvintillion
$10^{21} =$	1 000 000 000 000 000 000 000	seksillion
$10^{24} =$	1 000 000 000 000 000 000 000 000	septillion
$10^{27} =$	1 000 000 000 000 000 000 000 000 000	oktillion

**Bilimingizni sinab ko'ring!**



Bu bob materiallarini o'rganib chiqib, quyidagi masalalarni yecha olishingiz shart! Nazorat ishi oldidan o'zingizni sinab ko'ring!

**Test.** To'g'ri javobni aniqlang:

- Bo'linma bo'luvchiga ko'paytirilsa nima hosil bo'ladi?  
 A. Bo'linuvchi; B. Ko'paytma; D. Ko'paytuvchi; E. Bo'linma.
- $(6^3 + 13) \cdot 2 - 11$  ifodaning qiymatini hisoblashda qo'shish amali nechanchi o'rinda bajariladi?  
 A. Birinchi; B. Ikkinchi; D. Uchunchi; E. To'rtinchi.
- Ko'paytuvchilar o'zni almashtirilsa, ko'paytma haqida nima deyish mumkin?  
 A. O'zgaradi; B. Ko'payadi; D. Kamayadi; E. O'zgarmaydi.

**5- nazorat ishi namunasi**

- Ifodaning qiymatini toping:  
 a)  $58 \cdot 196$ ; b)  $4600 \cdot 1760$ ; d)  $405 \cdot 208$ ; f)  $36\ 490 : 178$ ; e)  $17\ 835 : 145$ .
- Tenglamani yeching:  
 a)  $14 \cdot x = 112$ ; b)  $133 : y = 19$ ; d)  $t : 15 = 90$ .
- Qulay usul bilan hisoblang:  
 a)  $25 \cdot 197 \cdot 4$ ; b)  $8 \cdot 567 \cdot 125$ ; d)  $50 \cdot 23 \cdot 40$ .
- Masalani tenglama tuzib yeching: Komil bir son o'yladi. Uni 3 ga ko'paytirib, ko'paytmadan 7 ni ayirdi. Natijada 50 hosil bo'ldi. Komil qanday sonni o'ylagan?
- Tenglama ildizini toping:  $x + x - 20 = x + 5$ .

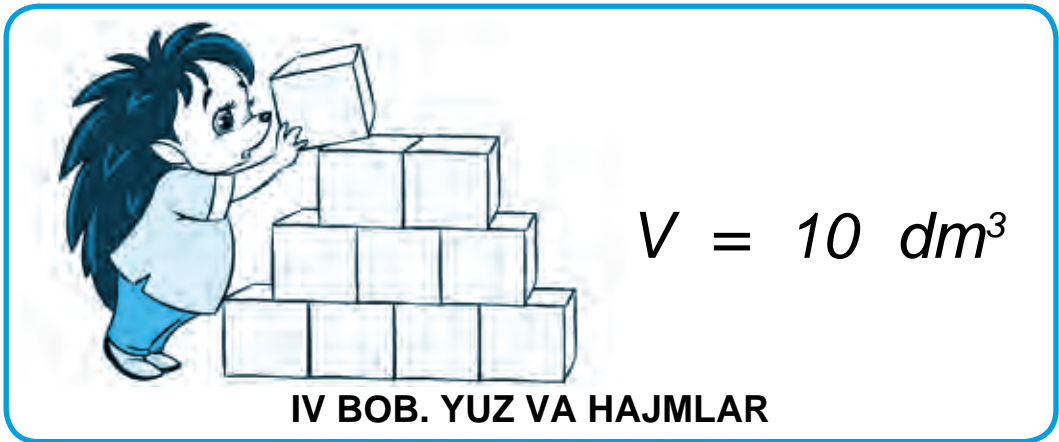

**20- §. FORMULALAR**

Matematikada ko'pgina qoidalar harflar yordamida yoziladi. Bunday holatlarda qoida *formula* bilan ifodalangan deb aytiladi. Shu paytgacha qo'shish va ko'paytirish qonunlarini formulalar bilan ifodalagan edik.

*1- misol.* Avtomobil 60 km/soat tezlik bilan 4 soat yurdi. Avtomobil necha km yo'l yurgan?

*Yechish.* Qoidaga ko'ra, bosib o'tilgan yo'lni topish uchun tezlik harakat vaqtiga ko'paytiriladi:

Bosib o'tilgan yo'l = Tezlik · Vaqt

Unga asoslansak,  $60 \cdot 4 = 240$  ya'ni avtomobil 240 km yo'l yurgan. Endi bosib o'tilgan yo'lni tezlik va vaqtga ko'ra topish formulasini yozamiz. Buning uchun yo'lni –  $S$ , tezlikni –  $v$ , vaqtni –  $t$  harflari bilan belgilasak, quyidagi formulaga ega bo'lamiz:

$S = v \cdot t$

Biror qoidaning harflar yordamida yozilgan ifodasiga *formula* deb ataladi. Masalan, tomonlari  $a$  va  $b$  bo'lgan to'g'ri to'rtburchak perimetri quyidagi formula yordamida ifodalanadi (1- rasm):

$P = 2a + 2b$

Tomoni  $a$  bo'lgan kvadratning perimetri esa quyidagi formula yordamida ifodalanadi (2- rasm):

$P = 4a$

Ularning to'g'riligini mustaqil tekshirib ko'ring.

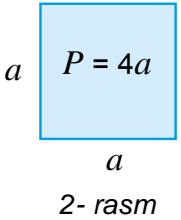
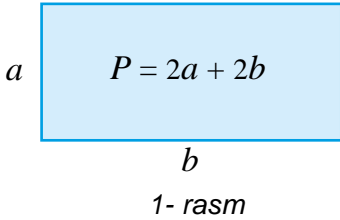

Formulalar ifodasida o'lchov birliklari yozilmaydi. Lekin javobni yozayotganda, albatta o'lchov birliklarini esdan chiqarmaslik kerak.

**2- misol.** Poyezd 70 km/soat tezlik bilan harakatlanmoqda. U 350 km masofani qancha soatda bosib o'tadi?

**Yechish.**  $S = v \cdot t$  formuladagi harflar o'rniga masalada berilgan ma'lum qiymatlarni qo'yamiz. Natijada,  $350 = 70 \cdot t$  tenglamani hosil qilamiz. Uni yechib  $t = 350 : 70$  yoki  $t = 5$  ekanligini topamiz.

Demak, poyezd 350 km masofani 5 soatda bosib o'tadi.

Masalaning sharti va yechimini daftarga quyidagicha yozish tavsiya etiladi:

**Berilgan:**

$$v = 70 \text{ km/soat}$$

$$S = 350 \text{ km}$$

$$t = ?$$

**Yechish:**

$$S = v \cdot t,$$

$$350 = 70 \cdot t,$$

$$t = 5.$$

**Javob:** 5 soatda.

### Savollarga javob bering!



1. Formula deb nimaga aytiladi? Misollar keltiring.
2. Bosib o'tilgan yo'lni topish formulasini yozing. Unda qatnashgan harflar bilan nima belgilanadi?
3. Bosib o'tilgan yo'l va tezlikka ko'ra vaqt qanday topiladi?
4. Bosib o'tilgan yo'l va vaqt berilgan bo'lsa, tezlik qanday topiladi?

### Sinfda bajariladigan mashqlar



- 448.**  $S = v \cdot t$  formulaga ko'ra:
- a) 986 km/min tezlik bilan 34 minutda;
  - b) 15 km/soat tezlik bilan 5 soatda bosib o'tilgan yo'lni toping.
- 449.** Bosib o'tilgan yo'lni topish formulasidan foydalanib,  $t$  – vaqtni toping:
- a)  $S = 72 \text{ km}$ ,  $v = 12 \text{ km/soat}$ ;
  - b)  $S = 360 \text{ m}$ ,  $v = 90 \text{ m/soat}$ .
- 450.** To'g'ri to'rtburchakning: a) tomonlari  $a = 8 \text{ dm}$ ,  $b = 12 \text{ dm}$  bo'lsa, uning perimetrini; b) perimetri 46 sm va tomonlaridan biri 12 sm bo'lsa, ikkinchi tomonini toping.
- 451.** Kvadratning: a) tomoni  $a = 32 \text{ mm}$  bo'lsa, uning perimetrini; b) perimetri 96 dm bo'lsa, uning tomonini toping.
- 452.** Mototsiklchi 75 km/soat tezlik bilan 4 soatda qancha yo'l bosadi?
- 453.** Sportchi 200 m masofani 25 s da bosib o'tdi. Sportchining tezligini toping.
- 
- 454.** Yer Quyosh atrofida 30 km/s tezlik bilan aylanadi. 1 soat davomida Yer qancha masofani bosib o'tadi? 1 minutda-chi?
- 455.** To'g'ri to'rtburchakning tomonlari 18 dm va 22 dm. Perimetri to'g'ri to'rtburchak perimetriga teng bo'lgan kvadrat tomonini toping.



456.  $S = v \cdot t$  yoki  $P = 2a + 2b$  formulalardan foydalanib jadvalni to'ldiring;

a)

$S$	3150 km	672 km	600 m	45 km
$v$		56 km/soat		5 m/s
$t$	7 soat		40 s	

b)

$a$	12 sm	8 dm	35 m
$b$	6 sm	6 dm	
$P$			220 m

457. 3- rasmda keltirilgan ko'pburchak tomonlarini chizg'ich yordamida o'lchang va uning perimetrini toping:



458. 4- rasmda keltirilgan ko'pburchak perimetrini berilgan ma'lumotlar asosida toping:

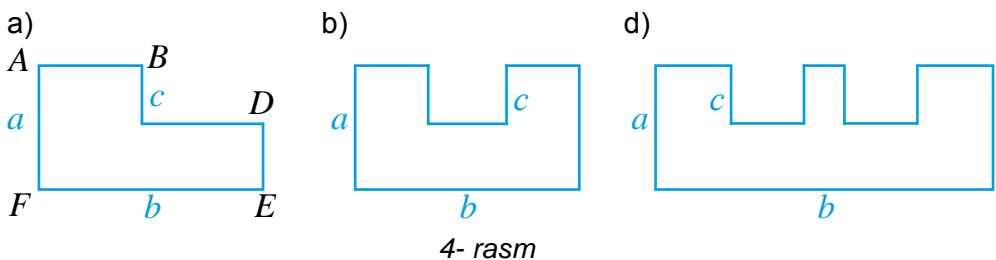

*Namuna:* a)  $AB + CD = b$  va  $BC + DE = a$  bo'lgani uchun  $P = 2a + 2b$ .



### Uyda bajariladigan mashqlar

459. Bosib o'tilgan yo'lni topish formulasidan foydalanib,  $v$  – tezlik qiymatini toping:

a)  $S = 450$  km,  $t = 90$  soat;    b)  $S = 280$  m,  $t = 7$  s.

460. To'g'ri to'rtburchakning perimetrini topish formulasi asosida to'g'ri to'rtburchakning: a) tomonlari  $a = 230$  sm,  $b = 12$  dm bo'lsa, uning perimetrini; b) perimetri 320 m va tomonlaridan biri 122 m bo'lsa, ikkinchi tomonini toping.

461. Kvadratning: a) tomoni  $a = 134$  dm bo'lsa, uning perimetrini; b) perimetri 288 m bo'lsa, uning tomonini toping.



462. Piyoda 70 m/min tezlik bilan 25 minutda qancha yo'l bosadi?

463. Tez yugurish musobaqasida sportchi 10 km masofani 5 m/s tezlik bilan bosib o'tdi. Sportchi qancha vaqt yugurgan?

464. To'g'ri to'rtburchakning bir tomoni 24 sm, ikkinchi tomoni birinchisidan 3 marta uzun. To'g'ri to'rtburchak perimetrini toping.

21- §.

**YUZ. TO'G'RI TO'RTBURCHAK VA KVADRAT YUZI FORMULALARI**

Quyidagi rasmda tasvirlangan devorlar nechta kvadratcha shaklidagi plitkalar bilan qoplangan?



a)

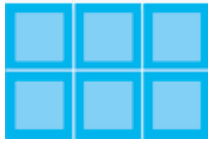

b)

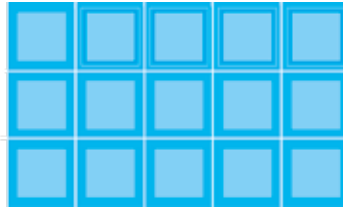

**21.1. Yuz haqida tushuncha**

Ko'pgina amaliy masalalarda biror yer maydoni, devor, pol yuzini o'lchashga to'g'ri keladi. Bunday hollarda oldin yuz o'lchov birligini tanlash lozim bo'ladi.

Yuz o'lchov birligi sifatida tomoni uzunlik birligiga teng bo'lgan kvadrat olinadi. Masalan, agar tomoni 1 m ga teng kvadrat olinsa, yuz o'lchov birligi 1 m<sup>2</sup> (1 kvadrat metr) bo'ladi. Agar tomoni 1 sm ga teng bo'lgan kvadrat tanlansa, yuz o'lchov birligi 1 sm<sup>2</sup> (1 kvadrat santimetr) bo'ladi.

Biror shaklning yuzini hisoblash deganda, uni nechta birlik kvadrat bilan qoplash mumkinligini topish tushuniladi.



Masalan, 1- rasmda tasvirlangan birinchi shakl – yuzi 1 sm<sup>2</sup> ga teng bo'lgan 6 ta, ikkinchi shakl esa – 8 ta kvadratlardan iborat.

Demak, ularning yuzi mos ravishda 6 sm<sup>2</sup> va 8 sm<sup>2</sup> ga teng bo'ladi.

a)

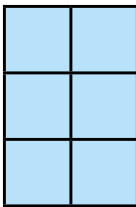

b)

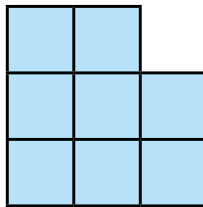

1- rasm

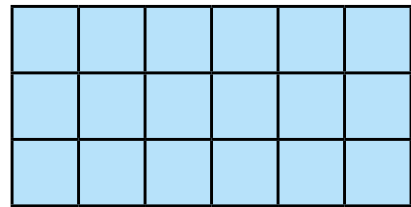

2- rasm

**21.2. To'g'ri to'rtburchak yuzi**

Bo'yi 3 sm, eni 6 sm bo'lgan to'g'ri to'rtburchakni qaraylik.

Bu to'g'ri to'rtburchak  $6 \cdot 3 = 18$  ta birlik kvadratlardan tashkil topgan (2- rasm). Demak, uning yuzi 18 sm<sup>2</sup> ga teng.

Agar to'g'ri to'rtburchak yuzini –  $S$ , bo'yini –  $a$ , enini esa –  $b$  harflari bilan belgilasak,

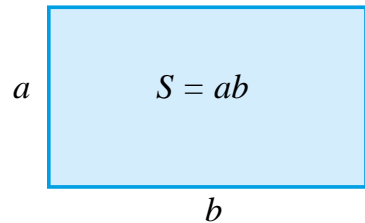

$$S = ab$$

ko'rinishidagi to'g'ri to'rtburchak yuzini hisoblash formulasiga ega bo'lamiz.



To'g'ri to'rtburchak yuzini topish uchun uning bo'yini eniga ko'paytirish kerak.

Ma'lumki, kvadrat tomonlari teng bo'lgan to'g'ri to'rtburchakdir. 3- rasmda tasvirlangan kvadratning tomoni 5 sm ga teng. U  $5 \cdot 5 = 25$  ta birlik kvadratdan iborat.

Demak, uning yuzi  $25 \text{ sm}^2$  ga teng.

Kvadrat tomonlarini  $a$  deb belgilasak, kvadratning yuzi

$$S = a^2$$

formula bilan ifodalanadi.

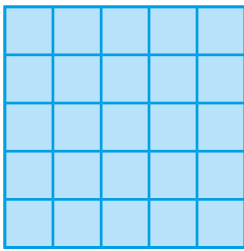
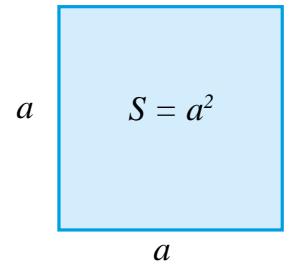

3- rasm

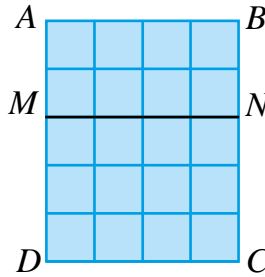

4- rasm

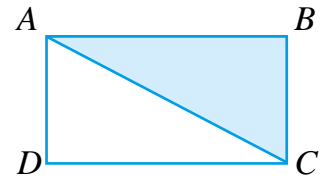

5- rasm

Birining ustiga ikkinchisi qo'yilganda ustma-ust tushadigan shakllar **teng shakllar** deb ataladi.



Teng shakllarning yuzi ham teng bo'ladi.

4- rasmda yuzi  $20 \text{ sm}^2$  ga teng bo'lgan  $ABCD$  to'g'ri to'rtburchak tasvirlangan. Uni  $MN$  kesma ikkita:  $ABNM$  va  $MNCD$  to'g'ri to'rtburchakka ajratadi. Birinchi to'g'ri to'rtburchak yuzi  $8 \text{ sm}^2$  ga, ikkinchisniki esa  $12 \text{ sm}^2$  ga teng.

Shu bilan birga  $20 = 8 + 12$ .

Demak, quyidagi xossaga egamiz:



Shaklning yuzi uni tashkil qilgan qismlari yuzi yig'indisiga teng.

5- rasmda  $AC$  kesma  $ABCD$  to'g'ri to'rtburchakni ikkita teng uchburchakka ajratadi.

Demak, bu uchburchaklar yuzi to'g'ri to'rtburchak yuzining yarmiga teng.



Savollarga javob bering!

1. Yuz o'lchov birligi sifatida nima olinadi?
2. Shaklning yuzi deganda nima tushuniladi?
3. To'g'ri to'rtburchak yuzini topish formulasini yozing.
4. Qanday shakllar teng deyiladi?
5. Teng shakllar yuzi haqida nima deyish mumkin?
6. Bo'laklari yuziga ko'ra butun shakl yuzi qanday topiladi?



Sinfda bajariladigan mashqlar



465. Bitta kichkina kvadratchaning yuzi  $1 \text{ sm}^2$  ga teng ekanligi ma'lum bo'lsa, 6- rasmdagi shakllarning yuzini va perimetrini ayting.

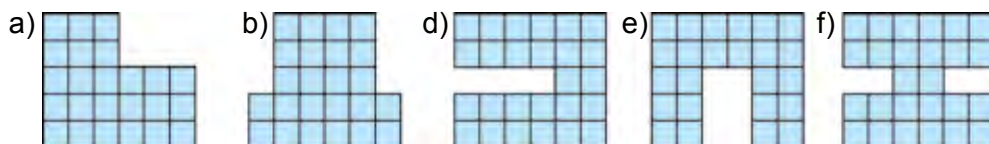

6- rasm

466. To'g'ri to'rtburchak yuzini hisoblash formulasidan foydalanib, uning yuzini toping.

a)  $a = 5 \text{ m}$ ,  $b = 3 \text{ m}$ ;

b)  $a = 4 \text{ dm}$ ,  $b = 360 \text{ sm}$ ;

d)  $a = 12 \text{ sm}$ ,  $b = 43 \text{ sm}$ ;

e)  $a = 12 \text{ m}$ ,  $b = 56 \text{ dm}$ .

*Ko'rsatma:* Hisoblashdan oldin berilganlarni bir xil o'lchov birligiga o'tkazing.

467.  $S = a \cdot b$  formulaga ko'ra jadvalni to'ldiring:

$a$	16 sm	130 m		43 m	240 sm
$b$	14 sm	80 m	24 dm		12 dm
$S$			432 $\text{dm}^2$	2322 $\text{m}^2$	

468. Chizg'ich yordamida tegishli kesmalarni millimetrdagi o'lchab, 7- rasmda keltirilgan shakllarning yuzini hisoblang.



7- rasm

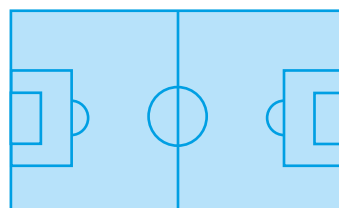

8- rasm

469. Tomoni 8 sm bo'lgan kvadratni yuzi  $4 \text{ sm}^2$  bo'lgan nechta kvadratchaga bo'lish mumkin?

470. Futbol maydonining bo'yi 110 m, eni esa 75 m ga teng (8- rasm). Futbol maydonining yuzini hisoblang.



471. To'g'ri to'rtburchakning bo'yi 34 sm, eni esa bo'yidan 12 sm qisqa bo'lsa, uning yuzini toping.

472. To'g'ri to'rtburchakning eni 12 sm, bo'yi esa enidan 3 marta uzun bo'lsa, uning yuzini toping.

473. 9- rasmda bo'yab ko'rsatilgan uchburchak yuzini toping.

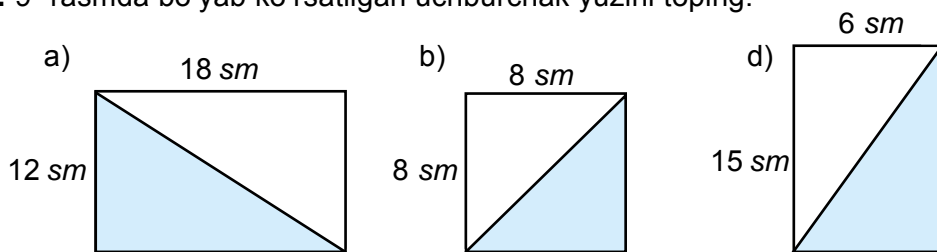

9- rasm

*Ko'rsatma:* Uchburchak yuzi to'g'ri to'rtburchak yuzining yarmiga teng.

474. 10- rasmdagi bo'yalgan shakllarning yuzini hisoblash formulasini keltirib chiqaring.



10- rasm

*Ko'rsatma:* Katta to'g'ri to'rtburchak yuzidan bo'yalmagan kichik to'g'ri to'rtburchak yuzi ayrilsa, bo'yalgan shakl yuzi hosil bo'ladi.

475. 11- rasmda berilgan ma'lumotlar asosida shakllarning yuzini toping.

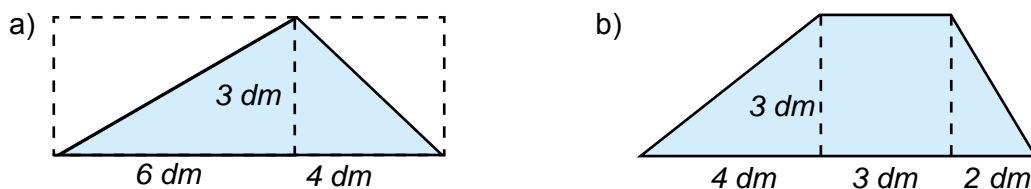

11- rasm



**Uyda bajariladigan mashqlar**

476. Bitta kichkina kvadratchaning yuzi  $1 \text{ dm}^2$  ga teng ekanligi ma'lum bo'lsa, 12- rasmdagi shakllarning yuzini va perimetrini toping.

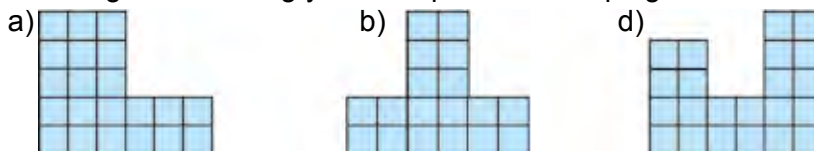

12- rasm

477. To'g'ri to'rtburchak yuzini hisoblash formulasidan foydalanib, uning yuzini toping.

- a)  $a = 6 \text{ m}$ ,  $b = 9 \text{ m}$ ;
- d)  $a = 220 \text{ sm}$ ,  $b = 12 \text{ dm}$ ;
- b)  $a = 12 \text{ dm}$ ,  $b = 880 \text{ sm}$ ;
- e)  $a = 35 \text{ m}$ ,  $b = 770 \text{ dm}$ .

478.  $S = ab$  formulaga ko'ra jadvalni to'ldiring;

$a$	22 sm	333 m		71 m	423 sm
$b$	54 sm	11 m	32 dm		9 dm
$S$			3232 dm <sup>2</sup>	3692 m <sup>2</sup>	



479. Tomoni 8 dm bo'lgan kvadrat shaklidagi qog'oz tomoni 1 sm bo'lgan kvadrat shaklidagi bo'lakchalarga bo'lindi. Natijada nechta bo'lakchalar hosil bo'ldi?

480. Tomoni 12 sm bo'lgan kvadratni yuzi 36 sm<sup>2</sup> bo'lgan nechta kvadratchalarga bo'lish mumkin.

481. 13- rasmda bo'yab ko'rsatilgan shakl yuzini toping:

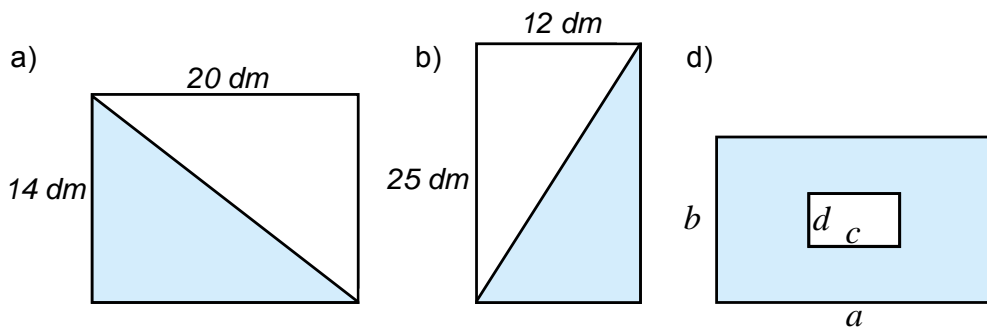

13- rasm

**Qiziqarli matematikaga oid masalalar**



14.a- rasmdagi 5 ta cho'pning o'rnini shunday almashtiringki, natijada 3 ta kvadrat hosil bo'lsin.

14.b- rasmdagi 2 ta cho'pning o'rnini shunday almashtiringki, natijada 5 ta teng kvadrat hosil bo'lsin.

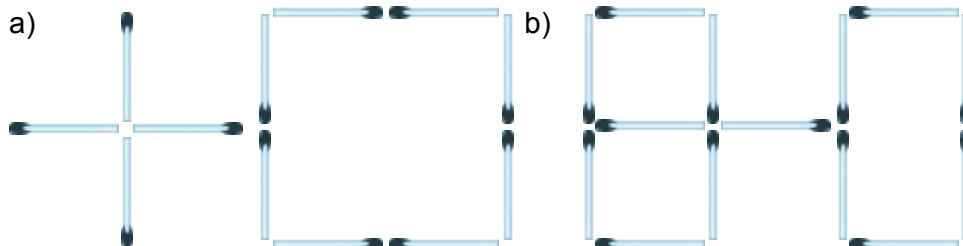

14- rasm

22- §.

YUZ O'LCHOV BIRLIKLARI

Shakllar yuzini o'lchash uchun turli o'lchov birliklaridan foydalaniladi. Siz yuzning kvadrat millimetr ( $\text{mm}^2$ ), kvadrat santimetr ( $\text{sm}^2$ ), kvadrat detsimetr ( $\text{dm}^2$ ), kvadrat metr ( $\text{m}^2$ ) o'lchov birliklarini bilasiz.

Qishloq xo'jaligida katta yer maydonlari yuzini o'lchash uchun *gektar* (ga) dan foydalaniladi. 1 gektar deb tomoni 100 m bo'lgan kvadrat yuzi qabul qilingan.

Demak, 1 ga = 100 · 100 kvadrat metr yoki

$$1 \text{ ga} = 10\,000 \text{ m}^2.$$

Kichikroq yer maydonlari yuzi *ar (sotix)* da o'lchanadi. 1 ar bu tomoni 10 m bo'lgan kvadrat yuzidir.

Demak, 1 ar = 10 · 10 kvadrat metr, yoki

$$1 \text{ ar} = 100 \text{ m}^2.$$

Yuqoridagilardan quyidagiga ega bo'lamiz:

$$1 \text{ ga} = 100 \text{ ar}.$$

Agar to'g'ri to'rtburchakning bo'yi va eni metrlarda berilgan bo'lsa, uning yuzi kvadrat metrlarda ifodalanadi. Agar to'g'ri to'rtburchakning tomonlari turli o'lchov birliklarda berilgan bo'lsa, oldin ularni bir xil (odatda eng kichik) o'lchov birligiga keltirib, so'ng yuz hisoblanadi.

*1- misol.* Agar to'g'ri to'rtburchakning eni 55 sm, bo'yi esa 1 m 20 sm bo'lsa, uning yuzini toping.

*Yechish.* Oldin to'g'ri to'rtburchakning bo'yini sm da ifodalaymiz:

$$1 \text{ m } 20 \text{ sm} = 120 \text{ sm}.$$

Unda to'g'ri to'rtburchakning yuzi

$$S = a \cdot b = 120 \cdot 55 = 6600 \text{ (sm}^2\text{)}.$$

*Javob:* 6600  $\text{sm}^2$ .

55 sm

S - ?

1 m 20 sm



Savollarga javob bering!

1. Yuz o'lchov birliklarini ayting.
2. Gektar va ar nima?
3. Yuz o'lchov birliklarini bir-biriga bog'laydigan munosabatlarni yozing.



Sinfda bajariladigan mashqlar

482. Quyidagi sxema asosida savollarga javob bering:

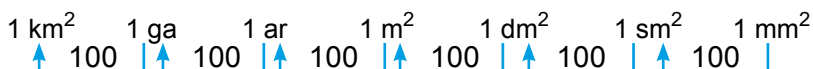

- a) 1  $\text{sm}^2$  necha  $\text{mm}^2$ ?
- d) 1  $\text{m}^2$  necha  $\text{dm}^2$ ?
- f) 1 ga necha  $\text{sm}^2$ ?

- b) 1  $\text{dm}^2$  necha  $\text{mm}^2$ ?
- e) 1 ar necha  $\text{sm}^2$ ?
- g) 1  $\text{km}^2$  necha ar?

483. Yuзи: a)  $1 \text{ sm}^2$ ; b)  $1 \text{ dm}^2$ ; d)  $1 \text{ m}^2$ ; e) 1 ar; f) 1 ga bo'lgan kvadrat tomonining uzunligi qancha bo'ladi?
484. Kvadrat santimetrda ifodalang:  $7 \text{ dm}^2$ ,  $12 \text{ dm}^2$ ,  $400 \text{ mm}^2$ ,  $1 \text{ dm}^2 35 \text{ sm}^2$ .
485. To'g'ri to'rtburchak shaklidagi tomorqaning eni 25 m va bo'yi 80 m. Uning yuzini toping va arda ifodalang.
486. To'g'ri to'rtburchak shaklidagi yer maydoni o'lchamlari 500 m va 380 m. Uning yuzini toping va gektarda ifodalang.
487.  $S = v \cdot t$  yoki  $P = 2a + 2b$  formulalardan foydalanib jadvalni to'ldiring:

a)

$a$	22 sm 8 mm	9 dm 3 sm
$b$	4 sm 9 mm	
$P$		2 m 3 dm

b)

$S$	3150 km	672 km	
$v$		56 km/soat	3 m/s
$t$	7 soat		3 min

488. To'g'ri to'rtburchakning bo'yi 4 sm 8 mm, eni esa bo'yidan 2 sm 4 mm uzun bo'lsa, uning yuzini toping.
489. Agar bitta katak yuzi  $1 \text{ sm}^2$  bo'lsa, 1- rasmda tasvirlangan to'g'ri to'rtburchaklar yuzini toping.

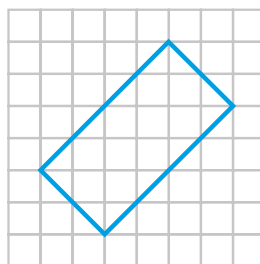
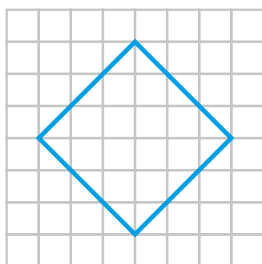

1-rasm



490. To'g'ri to'rtburchakning eni 13 dm 5 sm, bo'yi esa enidan 3 marta uzun bo'lsa, uning yuzini toping.
491. 15 ga yer yosh oilalarga tomorqa uchun taqsimlab berildi. Agar bitta tomorqa maydoni 6 sotix bo'lsa, jami nechta oila tomorqa olgan?
492. (*Amaliy ish*) Tegishli o'lchov ishlarini bajarib, daftar varag'i, parta, sinf doskasi, sinfxona poli, sport maydonchasining yuzini toping.
493. 2- rasmda hovli sxemasi tasvirlangan. Undan foydalanib, hovli yuzini toping.

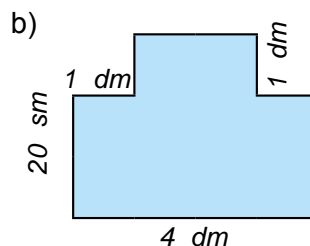
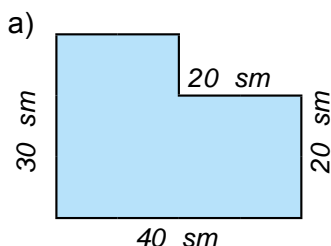

2-rasm

494. 3.a- rasmdagi uchburchak yuzini hisoblash formulasini yozing. Undan foydalanib, qolgan uchburchaklarning yuzini toping.

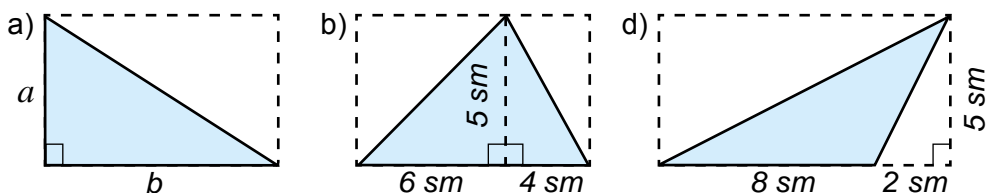

3- rasm



### Uyda bajariladigan mashqlar

495. Yuzi: a)  $4 \text{ sm}^2$ ; b)  $16 \text{ dm}^2$ ; d)  $81 \text{ m}^2$ ; e) 9 ar; f) 25 ga bo'lgan kvadratning tomoni uzunligi qancha bo'ladi?
496. Kvadrat metrda ifodalang: a)  $5 \text{ km}^2$ ; b)  $800 \text{ dm}^2$ ; d) 9 ar.
497. To'g'ri to'rtburchak shaklidagi tomorqaning eni 60 m, bo'yi 70 m. Uning yuzini toping va arda ifodalang.
498. To'g'ri to'rtburchak shaklidagi yer maydonining o'lchamlari 750 m va 440 m. Uning yuzini toping va gektarda ifodalang.



499. To'g'ri to'rtburchakning bo'yi 32 dm 9 sm, eni esa bo'yidan 22 sm qisqa bo'lsa, uning yuzini toping.
500. To'g'ri to'rtburchakning eni 45 dm 8 sm, bo'yi esa enidan 2 marta uzun bo'lsa, uning yuzini toping.
501. 4- rasmdagi uchburchak yuzini toping.

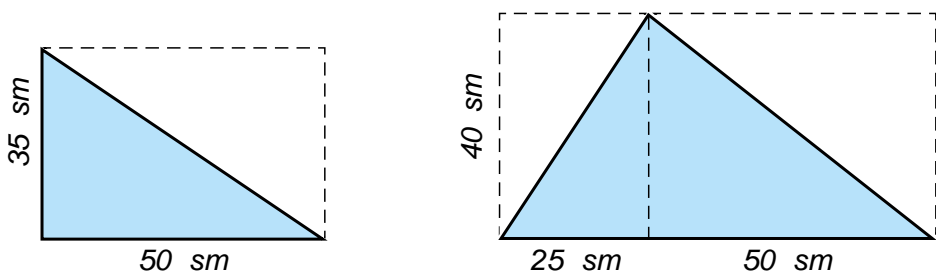

4- rasm

23- §.

TO'G'RI BURCHAKLI PARALLELEPIPED VA KUB

1- rasmdagi meva sharbati qutisi, o'chirg'ich, g'isht va taxta bo'lagi shakliga qarab *to'g'ri burchakli parallelepiped* haqida tasavvurga ega bo'lish mumkin.

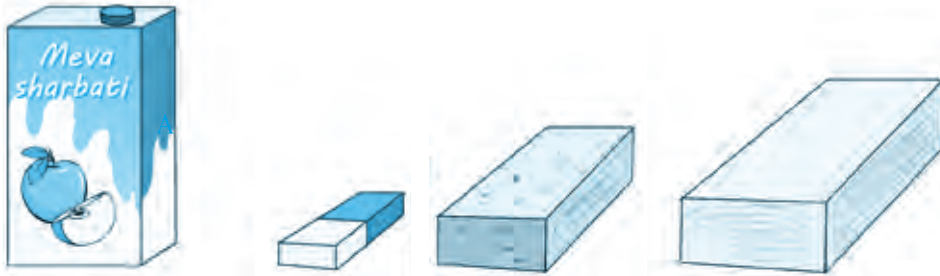

1- rasm

To'g'ri burchakli parallelepipedning sirti 6 ta to'g'ri to'rtburchakdan iborat (2- rasm). Ular to'g'ri burchakli parallelepipedning *yoqlari* deb ataladi.

To'g'ri burchakli parallelepipedning qarama-qarshi yoqlari o'zaro teng bo'ladi.

To'g'ri burchakli parallelepiped sirtining yuzi uning barcha yoqlari yuzlarining yig'indisidan iborat bo'ladi.

To'g'ri burchakli parallelepiped yoqlarining tomonlari parallelepipedning *qirralari*, uchlari esa parallelepipedning *uchlari* deb ataladi.

To'g'ri burchakli parallelepipedning 8 ta uchi, 12 ta qirradi va 6 ta yog'i bor.

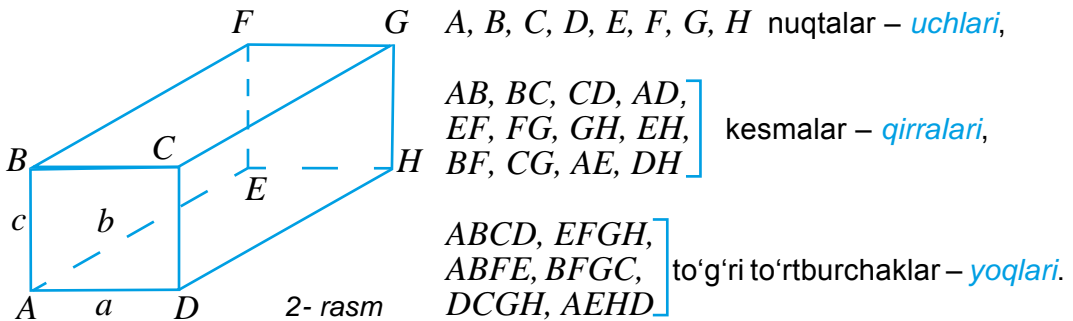

2- rasm

To'g'ri burchakli parallelepipedning har bir uchidan uning uchta qirradi chiqadi. 2- rasmda  $A$  uchidan chiquvchi qirralar uzunligi  $a$ ,  $b$  va  $c$  harflar bilan belgilangan. Bu qirralar mos ravishda to'g'ri burchakli parallelepipedning *eni*, *bo'yi* va *balandligi* deb ataladi.

Shunday qilib, har qanday to'g'ri burchakli parallelepiped uch o'lchamga:  $a$  – eni,  $b$  – bo'yi va  $c$  – balandligiga ega.

Hamma qirralari teng bo'lgan to'g'ri burchakli parallelepiped *kub* deb ataladi (3- rasm).

Ravshanki, kubning hamma yoqlari bir-biriga teng bo'lgan kvadratlardan iborat bo'ladi.

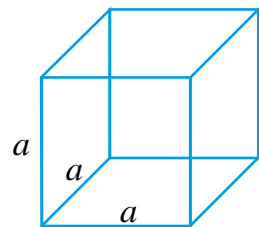

3- rasm

**1- misol.** 4.a- rasmda tasvirlangan to'g'ri burchakli parallelepipedning o'lchamlari: 5 sm, 3 sm va 2 sm. Bu parallelepiped sirtining yuzini toping.

**Yechish.** Ma'lumki, to'g'ri burchakli parallelepiped sirtining yuzi uning barcha yoqlari yuzlarining yig'indisiga teng. Berilgan to'g'ri burchakli parallelepiped yoqlari  $ABCD$ ,  $EFGH$ ,  $ADGH$ ,  $BEFC$ ,  $ABEH$ ,  $CFGD$  to'g'ri burchakli to'rtburchaklardan iborat.

Shu bilan birga, qarama-qarshi yotgan yoqlar o'zaro teng bo'ladi. Buni to'g'ri burchakli parallelepiped yoyilmasidan ham ko'rish mumkin (4.b- rasm).

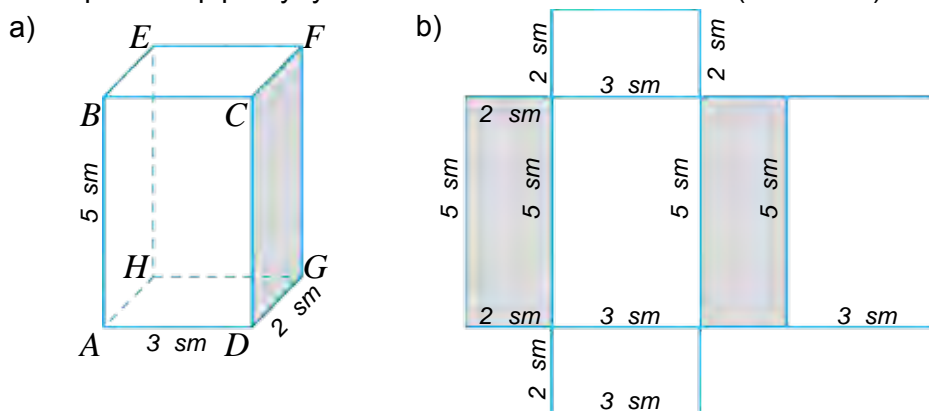

4- rasm

Haqiqatan ham  $ABCD$  va  $EFGH$  yoqlar – tomonlari 3 sm va 5 sm bo'lgan to'g'ri burchakli to'rtburchakdan iborat. Bu to'rtburchakning yuzi  $3 \cdot 5 = 15$  ( $\text{sm}^2$ ) ga teng.

$ADGH$  va  $BEFC$  yoqlar – tomonlari 3 sm va 2 sm bo'lgan to'g'ri burchakli to'rtburchakdan iborat. Bu to'rtburchakning yuzi  $3 \cdot 2 = 6$  ( $\text{sm}^2$ ) ga teng.

$ABEH$  va  $CFGD$  yoqlar – tomonlari 2 sm va 5 sm bo'lgan to'g'ri burchakli to'rtburchakdan iborat. Bu to'rtburchakning yuzi  $2 \cdot 5 = 10$  ( $\text{sm}^2$ ) ga teng.

Demak, berilgan to'g'ri burchakli parallelepiped sirtining yuzi  $2 \cdot 15 + 2 \cdot 6 + 2 \cdot 10 = 30 + 12 + 20 = 62$  ( $\text{sm}^2$ ) ga teng bo'ladi.

**Javob:**  $62 \text{ sm}^2$ .

Umumiy holda o'lchamlari  $a$ ,  $b$  va  $c$  bo'lgan to'g'ri burchakli parallelepiped sirtining yuzi:

$$S = 2(ab + bc + ac)$$

formula bilan ifodalanadi.

Qirradi  $a$  bo'lgan kub sirtining yuzi esa:

$$S = 6a^2$$

formula bilan ifodalanadi.



**Savollarga javob bering!**

1. To'g'ri burchakli parallelepiped shaklidagi narsalarga misol keltiring.
2. To'g'ri burchakli parallelepipedning nechta yog'i, qirradi va uchi bor?
3. To'g'ri burchakli parallelepipedning qirralari qanday shakldan iborat bo'ladi?
4. To'g'ri burchakli parallelepipedning yoqlari qanday shakldan iborat bo'ladi?
5. Kub deb nimaga aytiladi?



Sinfda bajariladigan mashqlar



502. (*Amaliy mashq*) 5- rasmda berilgan andozaga ko'ra daftaringizga to'g'ri burchakli parallelepiped chizing va uning uchlarini belgilang. Uning barcha uchlari, qirralari va yoqlarini yozing. Uning qaysi qirralari o'zaro teng bo'ladi? Uning qaysi yoqlari o'zaro teng bo'ladi?

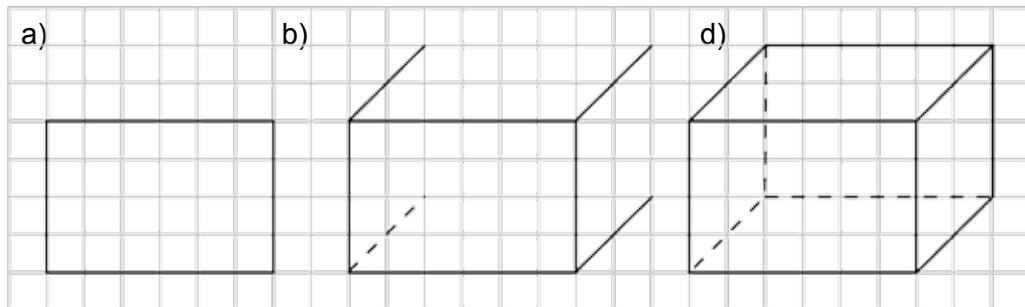

5- rasm

503. Eni 24 sm, bo'yi 32 sm va balandligi 18 sm bo'lgan to'g'ri burchakli parallelepipedning qirralari simdan yasaldi. Buning uchun qancha sim ishlatilgan?
504. Qutini 5- rasmda tasvirlangandek qilib bog'lash uchun kamida qancha ip kerak bo'ladi?
505. To'g'ri burchakli parallelepipedning o'lchamlari  $a$ ,  $b$  va  $c$  bo'lsa, uning qirralari uzunliklari yig'indisini hisoblash formulasini yozing.

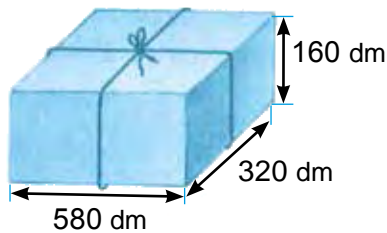

6- rasm

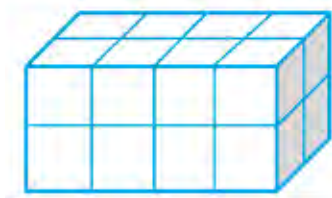

7- rasm

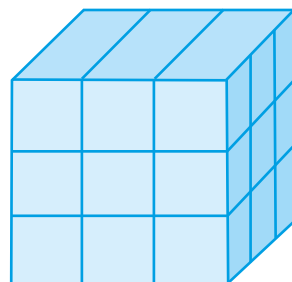

8- rasm



506. Qirradi 3 sm bo'lgan kublardan 7- rasmdagi parallelepiped yasaldi. Hosil bo'lgan parallelepipedning eni, bo'yi va balandligini toping. Bu parallelepiped nechta kubdan tuzilgan?
507. Qirradi 3 dm bo'lgan yog'och kub sirti qizil rangga bo'yaldi (8- rasm). Shundan so'ng u qirradi 1 dm bo'lgan kubchalarga bo'lib arralandi.
- a) Natijada nechta kubcha hosil bo'ldi?
- b) Ular orasida nechtasining bir yog'i, nechtasining ikki yog'i va nechtasining uchta yog'i bo'yalgan bo'ladi? Hech bir yog'i bo'yalmagan kubchalar ham hosil bo'ladimi?

**508.** O'lchamlari 12 dm, 21 dm va 14 dm bo'lgan to'g'ri burchakli parallelepiped sirtining yuzini hisoblang.

*Namuna:* Yuqorida ko'rilgan 1- misol.

**509.** 9- rasmda tasvirlangan to'g'ri burchakli parallelepiped shaklidagi usti ochiq akvariumni yasash uchun nechta va qanday o'lchamdagi shisha bo'laklari kerak bo'ladi?

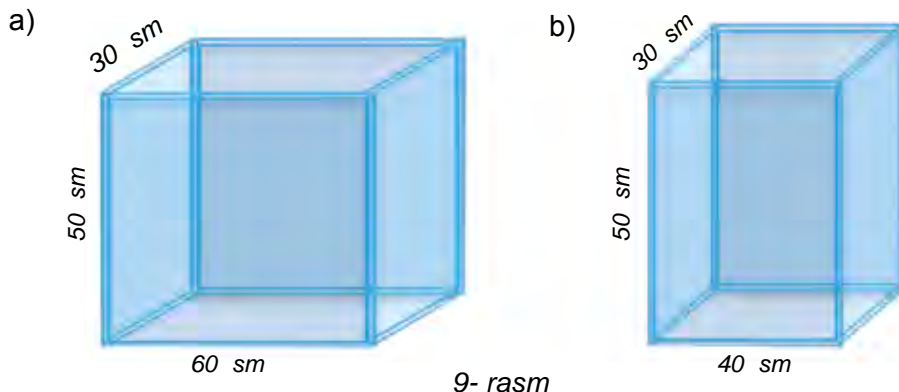

**510.** Qirradi 6 sm bo'lgan kubni bo'yash kerak. Buning uchun qanday kattalikdagi yuzani bo'yash kerak bo'ladi?

**511.** 10- rasmdagi jism nechta kubdan tashkil topgan?

**512.** Rangli qog'ozning o'lchamlari 16 sm va 6 sm. Bu qog'oz qirradi 4 sm bo'lgan kubni yelimlab qoplash uchun yetarli bo'ladimi?

**513.** Rangli qog'ozning o'lchamlari 12 sm va 8 sm. Bu qog'oz eni 3 sm, bo'yi 4 sm va balandligi 5 sm bo'lgan parallelepipedni yelimlab qoplash uchun yetarli bo'ladimi?

**514.** To'g'ri burchakli parallelepipedning o'lchamlari: a) 6 sm, 9 sm va 13 sm; b) 8 sm, 12 sm va 15 sm; d) 4 sm, 21 sm va 30 sm bo'lsa, uning sirti yuzini toping.

**515.** O'lchamlari 9 dm, 15 dm va 18 dm bo'lgan to'g'ri burchakli parallelepipedning sirtini bo'yash kerak. Agar  $1 \text{ dm}^2$  yuzani bo'yash uchun 2 g bo'yoq kerak bo'lsa, parallelepiped sirtini bo'yash uchun qancha bo'yoq kerak bo'ladi?

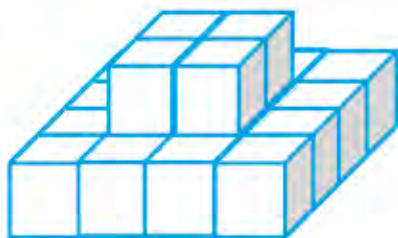

10- rasm

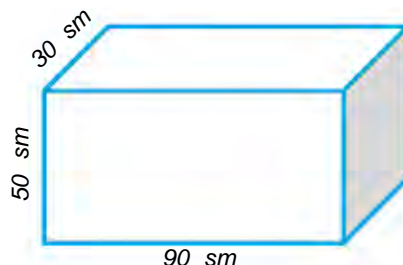

11- rasm

## Uyda bajariladigan mashqlar



- 516.** 11- rasmda to'g'ri burchakli parallelepiped berilgan. Uning uchlarini belgilang va barcha qirralari uzunligini toping. Bu qirralarning qaysilari o'zaro teng bo'ladi? Uning barcha yo'qlarini yozing va o'lchamlarini aniqlang. Bu yoqlardan qaysilari o'zaro teng bo'ladi?
- 517.** Eni 12 sm, bo'yi 25 sm va balandligi 13 sm bo'lgan to'g'ri burchakli parallelepipedning qirralari simdan yasaldi. Buning uchun qancha sim ishlatilgan?



- 518.** Qirradi  $a$  ga teng bo'lgan kub qirralari uzunliklari yig'indisini hisoblash formulasini yozing.
- 519.** Rangli qog'ozning o'lchamlari 12 sm va 7 sm. Bu qog'oz eni 4 sm, bo'yi 6 sm va balandligi 2 sm bo'lgan to'g'ri burchakli parallelepipedni yelimlab qoplash uchun yetarli bo'ladimi?



- 520.** To'g'ri burchakli parallelepipedning o'lchamlari: a) 3 sm, 6 sm va 7 sm; b) 11 dm, 13 dm va 13 dm; d) 40 dm, 9 dm va 6 dm bo'lsa, uning sirti yuzini toping.
- 521.** O'lchamlari 40 sm, 30 sm va 20 sm bo'lgan to'g'ri burchakli parallelepiped shaklidagi taxta bo'lagi sirtini bo'yash kerak. Agar  $1 \text{ dm}^2$  yuzani bo'yash uchun 2 g bo'yoq kerak bo'lsa, parallelepiped sirtini bo'yash uchun qancha bo'yoq kerak bo'ladi?

24- §.

## HAJM. HAJM O'LCHOV BIRLIKLARI. TO'G'RI BURCHAKLI PARALLELEPIPED HAJMI

Biri suv bilan to'ldirilgan, ikkinchisi bo'sh bo'lgan ikkita shisha idish olamiz (1.a- rasm). Birinchi idishdagi suvni ikkinchisiga quyamiz. Agar birinchi idishdagi hamma suv ikkinchi idishga sig'ib, uni limmo-lim to'ldirsa (1.b- rasm), bu – ikki idish bir xil sig'imga yoki hajmga ega ekanligini bildiradi.

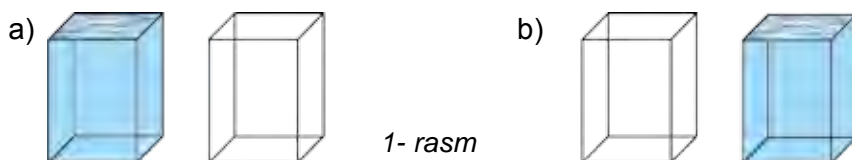

Biri suv bilan to'ldirilgan, ikkinchisi esa bo'sh bo'lgan yana boshqa ikkita shisha idish olamiz (2.a- rasm).

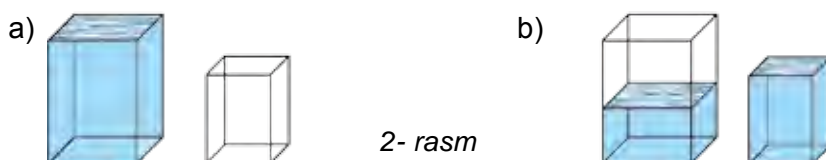

Birinchi idishdagi suvni ikkinchi idishga quyamiz. Bu holda ikkinchi idish limmo-lim to'lgandan keyin ham birinchi idishda yana suv qolsa (2.b- rasm), bu birinchi idishning hajmi ikkinchi idishning hajmidan katta yoki ikkinchi idishning hajmi birinchisidan kichik ekanligidan dalolat beradi.

### 24.1. Hajm tushunchasi

Biror kattalikni o'lchash uchun o'lchov birligini tanlash lozim bo'ladi. Yodingizda bo'lsa kerak, kesmaning uzunligini o'lchash uchun oldin uzunlik o'lchov birligi – birlik kesmani (3.a- rasm), to'g'ri to'rtburchak yuzini o'lchash uchun esa yuz o'lchov birligi sifatida kvadratni (3.b- rasm) tanlagan edik.

Xuddi shunga o'xshash, biror shaklning hajmini o'lchash uchun ham oldin hajm o'lchov birligi tanlanadi. Hajm o'lchov birligi sifatida birlik kub olinadi (3.d- rasm).

*Birlik kub* deb qirrasining uzunligi birlik kesmaga teng bo'lgan kubga aytiladi.

Masalan, *1 kub santimetr* – qirrasini 1 sm ga teng bo'lgan kub hajmiga teng. Bu hajm birligi  $sm^3$  tarzida yoziladi va *kub santimetr* deb o'qiladi.

**!** Biror shaklning hajmini o'lchash deganda, bu shaklga birlik kubdan nechtasini joylash mumkinligini aniqlashga aytiladi.

4- rasmda tasvirlangan shakl qirrası 1 sm ga teng bo'lgan 6 ta kubdan iborat. Demak, uning hajmi  $6 \text{ sm}^3$  ga teng.

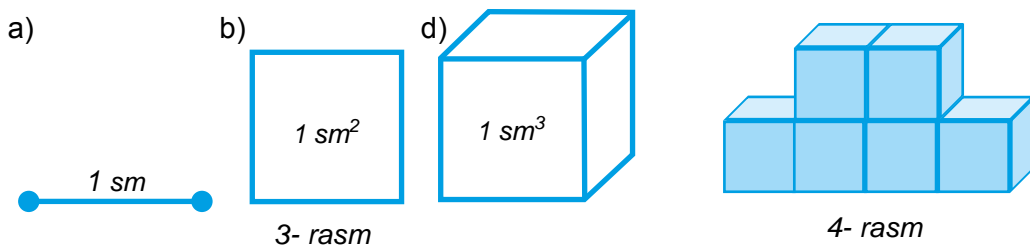

## 24.2. To'g'ri burchakli parallelepipedning hajmi

To'g'ri burchakli parallelepiped hajmini hisoblash qoidasini topaylik. Aytaylik, to'g'ri burchakli parallelepiped shaklidagi qutining bo'yi 4 sm, eni 3 sm, balandligi esa 5 sm bo'lsin (5.a- rasm). Uni qirrası 1 sm ga teng bo'lgan kubchalar bilan to'ldiramiz, ya'ni uning hajmini  $\text{sm}^3$  da o'lchaymiz.

Qutining pastki asosiga jami  $3 \cdot 4 = 12$  ta kubcha bitta qatlam bo'lib joylashadi (5.a- rasm). Qutini kubchalar bilan to'la to'ldirish uchun esa bunday qatlamlardan 5 tasini ustma-ust qo'yish lozim bo'ladi (5.b- rasm), chunki uning balandligi 5 sm ga teng. Shunday qilib, qutiga jami  $(3 \cdot 4) \cdot 5 = 60$  ta kubchani joylash mumkin ekan.

Demak, qutining hajmi  $60 \text{ sm}^3$  ga teng bo'ladi.

E'tibor bersangiz, to'g'ri burchakli parallelepiped shaklidagi bu qutining hajmi uning uchta o'lchovi: eni, bo'yi va balandligining ko'paytmasiga teng bo'ldi.

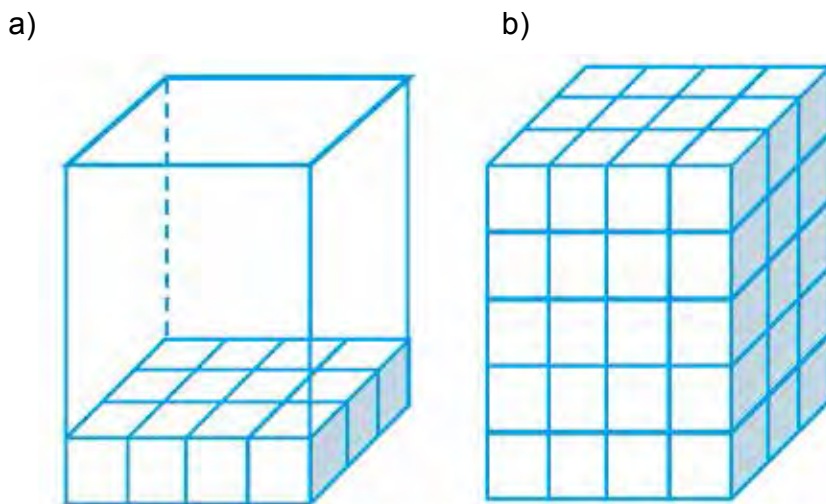

5- rasm

To'g'ri burchakli parallelepipedning hajmi bo'yi, eni va balandligi ko'paytmasiga teng.



Agar to'g'ri burchakli parallelepiped hajmini –  $V$ , bo'yini –  $a$ , enini –  $b$  va balandligini –  $c$  harflari bilan belgilasak (6- rasm), unda quyidagi formulaga ega bo'lamiz:

$$V = a \cdot b \cdot c$$

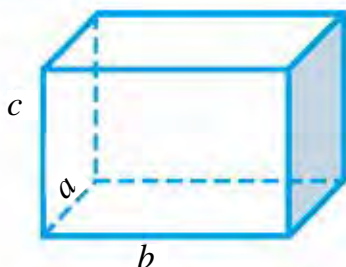

$$V = abc$$

6- rasm

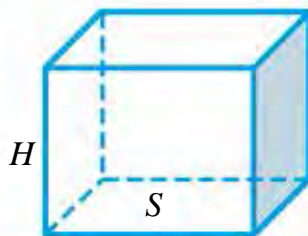

$$V = S H$$

7- rasm

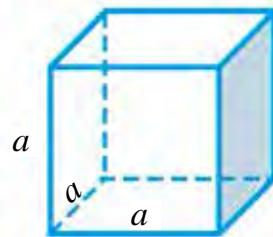

$$V = a^3$$

8- rasm

Lekin to'g'ri burchakli parallelepiped eni va bo'yining ko'paytmasi ( $a \cdot b$ ) uning asosining yuziga teng (7- rasm). Shuning uchun, parallelepiped asosining yuzini –  $S$  va balandligini –  $H$  harflari bilan qayta belgilasak, unda to'g'ri burchakli parallelepiped hajmini topish uchun yangi formulaga ega bo'lamiz:

$$V = S \cdot H$$

Endi qirradi 5 sm ga teng bo'lgan kubning hajmini topaylik. Kub ham to'g'ri burchakli parallelepiped bo'lgani uchun uning hajmi  $5 \cdot 5 \cdot 5 = 125 \text{ (sm}^3\text{)}$  ga teng bo'ladi.

Umumiy holda, qirradi  $a$  ga teng bo'lgan kubning hajmi

$$V = a^3$$

formula bilan ifodalanadi (8- rasm).

### 24.3. Hajm o'lchov birliklari

Hajmlarni o'lchash uchun millimetr kub ( $\text{mm}^3$ ), detsimetr kub ( $\text{dm}^3$ ), metr kub ( $\text{m}^3$ ), kilometr kub ( $\text{km}^3$ ) kabi o'lchov birliklaridan foydalaniladi.

Suyuqliklar bilan ish ko'rilganda 1  $\text{dm}^3$  ni boshqacha litr ( $l$ ) deb ham atashadi.

$$1 \text{ litr} = 1 \text{ dm}^3$$

Endi hajm o'lchov birliklari orasidagi ba'zi munosabatlarni aniqlaylik.

Ma'lumki, 1 m = 10 dm. Unda 1  $\text{m}^3$  qirradi 1 m (yoki 10 dm) bo'lgan kub hajmiga teng bo'ladi. Bu kub hajmini  $\text{dm}^3$  da ifodalaylik:

$$1 \text{ m}^3 = 1 \text{ m} \cdot 1 \text{ m} \cdot 1 \text{ m} = 10 \text{ dm} \cdot 10 \text{ dm} \cdot 10 \text{ dm} = 1000 \text{ dm}^3$$

Demak,

$$1 \text{ m}^3 = 1000 \text{ dm}^3.$$

Xuddi shunga o'xshash,

$$1 \text{ dm}^3 = 1000 \text{ sm}^3, \quad 1 \text{ m}^3 = 1\,000\,000 \text{ sm}^3, \quad 1 \text{ km}^3 = 1\,000\,000\,000 \text{ m}^3$$

ekanligini ham aniqlash mumkin.

### Savollarga javob bering!



1. Ikki idishning sig'imi (hajmi) qanday taqqoslanadi?
2. Hajm o'lchov birligi sifatida nima olinadi?
3. Shaklning hajmini o'lchash deganda nima tushuniladi?
4. Hajmning qanday o'lchov birliklarini bilasiz?
5. To'g'ri burchakli parallelepiped hajmini hisoblash formulasini ayting.

### Sinfda bajariladigan mashqlar



**522.** 9- rasmdagi shakllar qirrası 1 dm ga teng bo'lgan birlik kubchalardan tuzilgan. Bu shakllarning hajmini toping.

a)

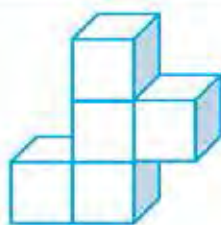

b)

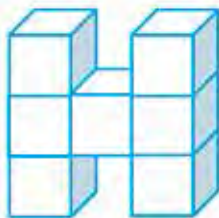

d)

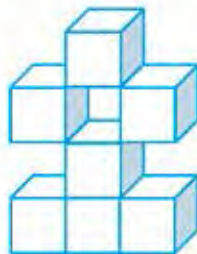

e)

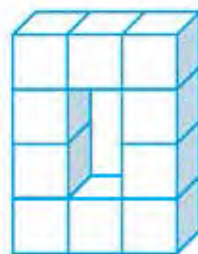

9- rasm

**523.** To'g'ri burchakli parallelepipedda: a)  $a = 12 \text{ sm}$ ,  $b = 15 \text{ sm}$ ,  $c = 8 \text{ sm}$ ;  
b)  $a = 18 \text{ dm}$ ,  $b = 9 \text{ dm}$ ,  $c = 12 \text{ dm}$ . Uning hajmini hisoblang.

**524.**  $1 \text{ m}^3$  havoning massasi 1290 g. O'lchamlari 8 m, 6 m va 3 m bo'lgan sinfxona havosining massasini toping.

**525.** Asosining yuzi va balandligi bo'yicha to'g'ri burchakli parallelepipedning hajmini toping: a)  $S = 15 \text{ sm}^2$ ,  $H = 4 \text{ sm}$ ; b)  $S = 36 \text{ dm}^2$ ,  $H = 2 \text{ dm}$ .

**526.** To'g'ri burchakli parallelepiped shaklidagi omborxonaning bo'yi 24 m, eni 13 m va hajmi  $3432 \text{ m}^3$ . Uning balandligini toping.

**527.** To'g'ri burchakli parallelepipedda a)  $V = 7290 \text{ sm}^3$ ,  $H = 54 \text{ sm}$ ;

b)  $V = 1170 \text{ dm}^3$ ,  $H = 78 \text{ dm}$  bo'lsa, uning asosi yuzini toping.

**528.** Santimetrda ifodalang:

a) 2 m 3 dm; || b) 18 m 7 dm; || d) 2100 mm; || e) 3 dm 30 sm 20 mm.

**529.** Kvadrat santimetrda ifodalang:

a)  $53 \text{ dm}^2$ ; || b)  $18\,000 \text{ mm}^2$ ; || d)  $3 \text{ m}^2 7 \text{ dm}^2$ ; || e)  $4 \text{ m}^2 30 \text{ dm}^2$ .



530. Litrda ifodalang:

- a)  $5 \text{ dm}^3$ ; || b)  $21\,000 \text{ sm}^3$ ; || d)  $3 \text{ dm}^3\ 7000 \text{ sm}^3$ ; || e)  $2 \text{ m}^3\ 3 \text{ dm}^3$ .

531. Temirdan qirradi 20 sm bo'lgan kub shaklidagi detal tayyorlandi.  $10 \text{ sm}^3$  hajmdagi temir parchasining massasi 78 g bo'lsa, detalning massasini toping.

532. Atirsovunning o'lchamlari 8 sm, 4 sm va 2 sm. Sovun ishlatilganda har kuni uning hajmi  $4 \text{ sm}^3$  ga kamayib boradi. Sovundan necha kun foydalanish mumkin?

533. 10- rasmdagi akvariumlar yuqori yog'i sathidan 10 sm past qilib suv bilan to'ldirilgan. Har bir akvariumdagi suv hajmini toping.

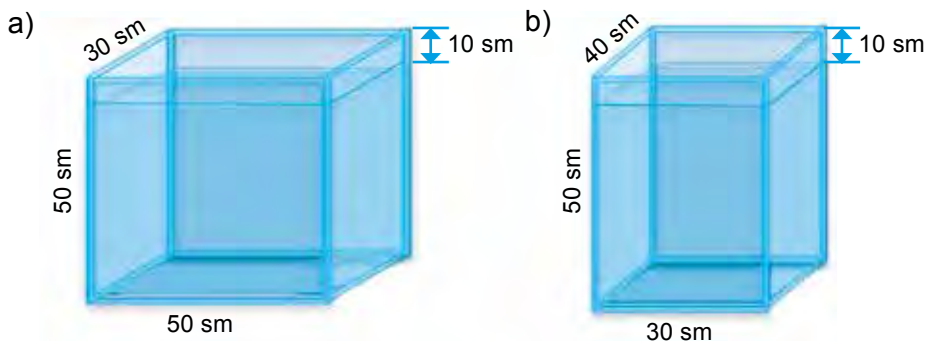

10- rasm

534. 11-rasmda tasvirlangan xonaning o'lchamlariga ko'ra, polining yuzini, devorlari yuzini va hajmini toping.

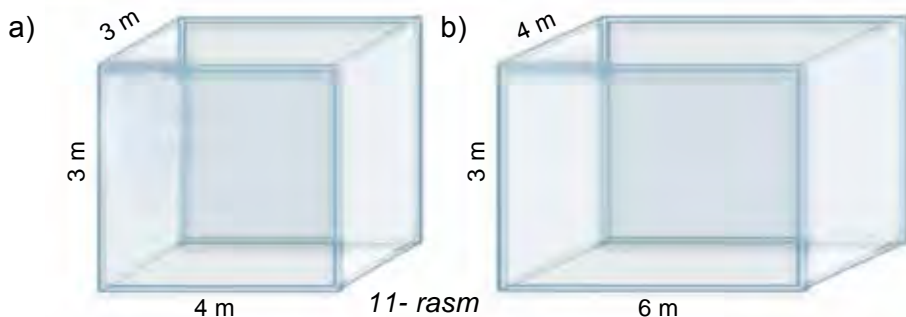

11- rasm

535. 12- rasmda tasvirlangan jismlarning hajmini va sirtining yuzini toping:

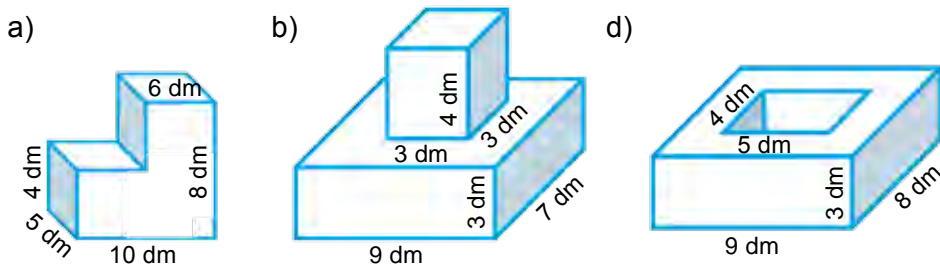

12- rasm



Uyda bajariladigan mashqlar



536. 13- rasmdagi shakllar qirrası 1 dm ga teng bo'lgan birlik kubchalardan tuzilgan. Bu shakllarning hajmini toping. Ularning orasida hajmlari teng bo'lgan shakllarni aniqlang.

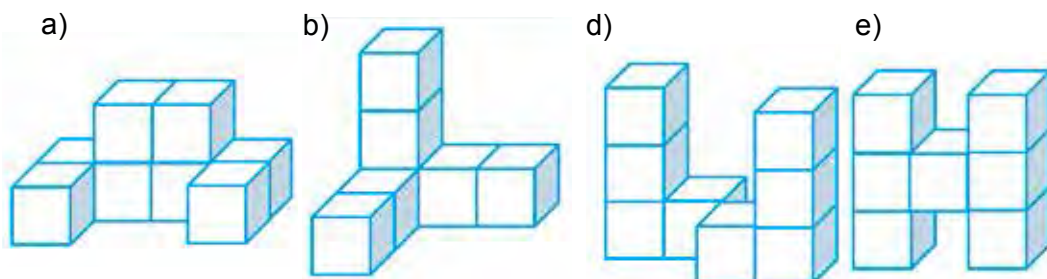

13- rasm

537. To'g'ri burchakli parallelepipedda a)  $a = 6$  m,  $b = 12$  m,  $c = 7$  m; b)  $a = 2$  dm,  $b = 13$  dm,  $c = 6$  dm bo'lsa, uning hajmini hisoblang.

538. Yog'och taxtaning bo'yi 6 m, eni 2 dm va qalinligi 25 sm.  $1 \text{ dm}^3$  taxtaning massasi 650 g ekani ma'lum bo'lsa, taxtaning massasini toping.

539. To'g'ri burchakli parallelepipedning hajmi  $3366 \text{ sm}^2$  va balandligi 33 sm bo'lsa, asosining yuzini toping.



540. Agar bitta kichik kubchanning hajmi  $1 \text{ dm}^3$  bo'lsa, 14- rasmda tasvirlangan jismlarning hajmini aniqlang.

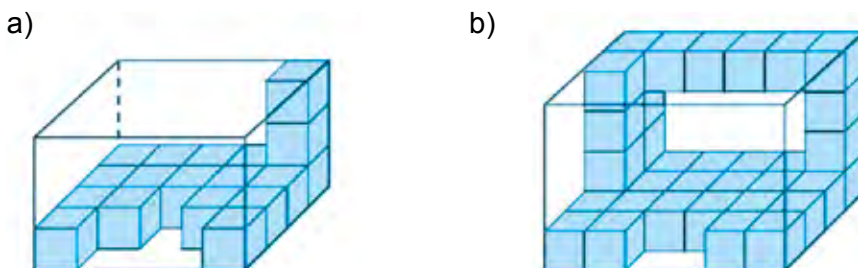

14- rasm

541. Santimetrda ifodalang:

- a) 5 m 8 dm;                      b) 11 m 9 dm;                      d) 6 m 3 dm;  
e) 800 mm;                        f) 2 dm 12 sm 40 mm.

542. Kub santimetrda ifodalang:

- a)  $8 \text{ dm}^3$ ;                              b)  $22 \text{ dm}^3$ ;                              d)  $5 \text{ dm}^3 80 \text{ sm}^3$ ;  
e)  $120\,000 \text{ mm}^3$ ;                      f)  $7 \text{ m}^3 9 \text{ dm}^3$ .

543. Alumiynidan o'lchamlari 7 sm, 10 sm va 12 sm bo'lgan, to'g'ri burchakli parallelepiped shaklidagi detal tayyorlandi.  $10 \text{ sm}^3$  hajmdagi alumiyniy parchasining massasi 27 g bo'lsa, detalning massasini toping.

**25.1. Bo'laklarga doir masalalar yechish**

*1- misol.* Qulupnaydan murabbo tayyorlash uchun 3 hissa (bo'lak) qulupnayga 2 hissa (bo'lak) shakar aralashtirish lozim. 18 kg qulupnayga qancha shakar aralashtirish kerak bo'ladi?

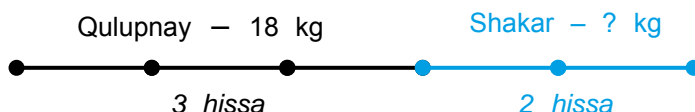

*Yechish.* Shartga ko'ra, 18 kg qulupnay 3 hissani tashkil qiladi. Demak, 1 hissa qulupnay  $18 : 3 = 6$  (kg) ga teng. Unda, shakar 2 hissani, ya'ni  $2 \cdot 6 = 12$  (kg) ni tashkil qiladi.

*Javob:* 12 kg shakar aralashtirish zarur.

*2- misol.* Beton qorishmasi tayyorlash uchun 3 hissa qumga 2 hissa sement aralashtiriladi. 60 kg beton qorishmasi tayyorlash uchun necha kilogramm qum va necha kilogramm sement olish kerak?

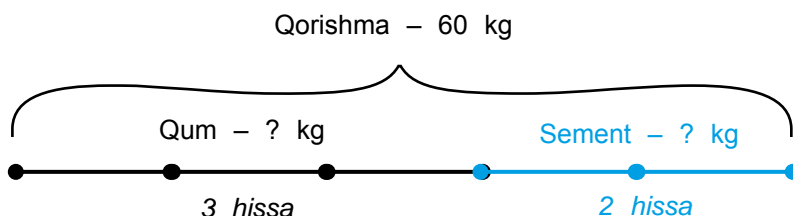

*Yechish.* Beton qorishmasi jami  $3 + 2 = 5$  hissadan iborat. Unda 1 hissa qorishma massasi  $60 : 5 = 12$  (kg) ni tashkil qiladi.

Demak, 60 kg beton qorishmasi tayyorlash uchun qumdan 3 hissa, ya'ni  $3 \cdot 12 = 36$  (kg), sementdan esa 2 hissa, ya'ni  $2 \cdot 12 = 24$  (kg) kerak bo'ladi

*Javob:* 36 kg qum, 24 kg sement kerak bo'ladi.

**25.2. IV bobni takrorlashga doir masalalar**

**544.** Bosib o'tilgan yo'l formulasidan foydalanib,  $v$  – tezlik qiymatini toping:

a)  $S = 180$  km,  $t = 9$  soat; || b)  $S = 140$  m,  $t = 28$  s.

**545.** Bosib o'tilgan yo'l formulasidan foydalanib,  $t$  – vaqtni toping:

a)  $S = 121$  km,  $v = 11$  km/soat; || b)  $S = 990$  m,  $v = 11$  m/soat.

**546.** To'g'ri to'rtburchakning:

a) tomonlari  $a = 302$  sm,  $b = 21$  dm bo'lsa, uning perimetri va yuzini;

b) perimetri 444 m va tomonlaridan biri 120 m bo'lsa, ikkinchi tomonini toping.

547. Kvadratning tomonlari 31 dm bo'lsa, perimetri va yuzini toping.
548. To'g'ri to'rtburchakning tomonlari 56 sm va 44 sm. Perimetri to'g'ri to'rtburchak perimetriga teng bo'lgan kvadrat tomonini toping.
549. To'g'ri to'rtburchakning bir tomoni 108 sm, ikkinchi tomoni birinchisidan 4 marta qisqa. To'g'ri to'rtburchak perimetrini va yuzini toping.
550. To'g'ri to'rtburchakda: a)  $a = 16$  m,  $b = 11$  m; b)  $a = 21$  dm,  $b = 430$  sm; d)  $a = 20$  sm,  $b = 8$  dm; e)  $a = 53$  m,  $b = 550$  dm bo'lsa, yuzini va perimetrini toping.
551. To'g'ri to'rtburchak haqida berilgan ma'lumotlardan foydalanib jadvalni to'ldiring;

$a$	23 sm	73 m		17 m
$b$	27 sm	19 m	23 dm	
$S$			1242 dm <sup>2</sup>	1037 m <sup>2</sup>

552. Tomoni 2 m bo'lgan kvadrat shaklidagi qalin qog'oz, tomoni 1 dm bo'lgan kichkina kvadrat shaklidagi bo'laklarga bo'lindi. Natijada nechta bo'lakcha hosil bo'ldi?
553. Tomoni 24 sm bo'lgan kvadratni yuzi 144 sm<sup>2</sup> bo'lgan nechta kvadratchaga bo'lish mumkin.
554. Yuzi: a) 144 sm<sup>2</sup>; b) 64 dm<sup>2</sup>; d) 576 m<sup>2</sup>; e) 121 ar; f) 169 ga bo'lgan kvadratning tomoni va perimetri uzunligini toping.
555. To'g'ri to'rtburchak shaklidagi tomorqaning eni 70 m va bo'yi 80 m. Uning yuzini toping va arda ifodalang.
556. To'g'ri to'rtburchak shaklidagi yer maydoni o'lchamlari 1500 m va 2400 m. Uning yuzini toping va gektarda ifodalang.
557. Eni 15 sm, bo'yi 2 dm va balandligi 18 sm bo'lgan to'g'ri burchakli parallelepipedning qirralari simdan yasaldi. Buning uchun qancha sim ishlatilgan?
558. O'lchamlari 6 dm, 12 dm va 17 dm bo'lgan to'g'ri burchakli parallelepiped sirtining yuzini hisoblang.
559. Qirradi 25 dm bo'lgan kubni bo'yash kerak. Buning uchun qanday kattalikdagi yuzani bo'yash kerak bo'ladi?
560. Bir kub metr havoning massasi 1290 g. O'lchamlari 20 m, 10 m va 4 m bo'lgan xonadagi havoning massasi necha kilogramm?
561. To'g'ri burchakli parallelepiped shaklidagi, bo'yi 21 m, eni 13 m va chuqurligi 3 m bo'lgan o'ra qazish kerak. Buning uchun qancha hajmdagi tuproqni qazib chiqarish kerak bo'ladi?

562. Yog'och taxtaning bo'yi 8 m, eni 3 dm va qalinligi 30 sm.  $1 \text{ dm}^3$  taxtaning massasi 650 g ekani ma'lum bo'lsa, taxtaning massasini toping.
563. To'g'ri burchakli parallelepiped shaklidagi majlislar zalining bo'yi 40 m, eni 25 m va hajmi  $6000 \text{ m}^3$ . Uning balandligini toping.
564. Aluminiydan o'lchamlari 17 sm, 20 sm va 21 sm bo'lgan, to'g'ri burchakli parallelepiped shaklidagi detal tayyorlandi.  $10 \text{ sm}^3$  hajmdagi aluminiy parchasining massasi 27 g bo'lsa, detalning massasini toping.
565. Devorning balandligi 3 m, uzunligi 30 m va qalinligi 40 sm. G'ishtning o'lchamlari: 30 sm, 15 sm, 10 sm. Devorni qurishga nechta g'isht kerak bo'ladi?
566. Xona polining eni 6 m, bo'yi 15 m.  $1 \text{ m}^2$  polni bo'yash uchun 200 g bo'yoq sarflanadi. Xona polini bo'yash uchun qancha bo'yoq kerak?



### Bilimingizni sinab ko'ring!

Bu bob materiallarini o'rganib chiqib, quyidagi masalalarni yecha olishingiz shart! Nazorat ishi oldidan o'zingizni sinab ko'ring!

**Test.** To'g'ri javobni aniqlang

- Biror qoidaning harflar yordamidagi ifodasi nima deb ataladi?  
**A.** Sonli ifoda; || **B.** Harfli ifoda; || **D.** Formula; || **E.** Tenglama.
- To'g'ri burchakli parallelepipedning nechta yog'i bor?  
**A.** 12 ta; || **B.** 4 ta; || **D.** 6 ta; || **E.** 16 ta.
- Qaysi javobda kub hajmi formulasi keltirilgan?  
**A.**  $V = abc$ ; || **B.**  $V = a^3$ ; || **D.**  $S = ab$ ; || **E.**  $S = a^2$ .

### 6- nazorat ishi namunasi

- Hisoblang: a)  $(5^3 + 13^2) : 21$ ; || b)  $180 \cdot 94 - 47\,700 : 45 + 4946$ .
- To'g'ri burchakli to'rtburchak shaklidagi yer maydonining bo'yi 125 m, eni 96 m. Yer maydoning yuzini toping va uni ar da ifodalang.
- To'g'ri burchakli parallelepiped o'lchamlari 4 m, 3 m va 5 dm. Uning hajmini toping.
- a) Tezligi 80 km/soat bo'lgan avtomashina 3 soatda qancha yo'l bosib o'tadi? b) Ko'lda 15 km/soat tezlikda 90 km suzgan katerning suzish vaqtini toping.
- Qirrası 6 dm bo'lgan kub sirtining yuzi va hajmini toping.

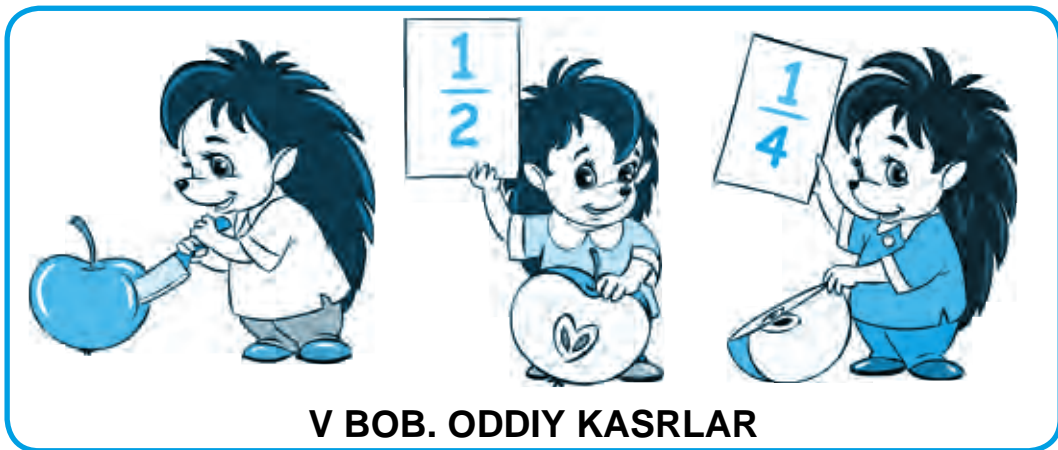

26- §. AYLANA VA DOIRA

Sirkul (pargar)ning ninali uchini  $O$  nuqtaga qo'yib, qalamli uchini shu nuqta atrofida aylantirib chizamiz (1- rasm). Hosil bo'lgan shakl *aylana* deb ataladi (2- rasm).

Aylana tekislikni ikki qismga ajratadi. Tekislikning aylana ichidagi bo'lagi (aylana bilan birgalikda) *doira* deb ataladi (3- rasm).

$O$  nuqta *aylana (doira) markazi* deb ataladi. Aylanani chizayotganda sirkul uchlari orasidagi masofa o'zgarmadi. Shuning uchun aylananing barcha nuqtalari uning markazidan baravar uzoqlikda yotadi.

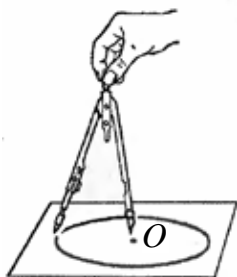

1- rasm

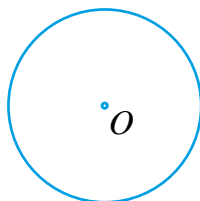

2- rasm

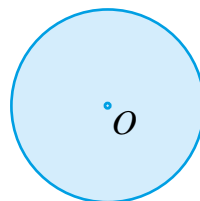

3- rasm

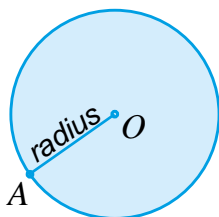

4- rasm

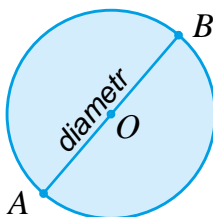

5- rasm

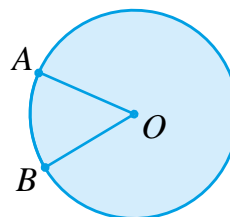

6- rasm

Aylananing  $O$  markazini uning biror  $A$  nuqtasi bilan tutashtiradigan  $OA$  kesma *aylananing radiusi* deb ataladi (4- rasm). Shuningdek, aylananing radiusi u chegaralab turgan doiraning radiusi ham bo'ladi.

Ravshanki, aylananing barcha radiuslari bir-biriga teng bo'ladi.

5- rasmda  $AB$  kesma aylana (doira) markazidan o'tib, uning  $A$  va  $B$  nuqtalarini tutashtirayapti.  $AB$  kesma *aylana (doira) diametri* deb ataladi.

Aylananing  $AB$  diametri  $AO$  va  $OB$  radiuslardan tashkil topgan. Shuning uchun aylana diametri uning radiusidan 2 marta uzun bo'ladi.

6- rasmda  $A$  va  $B$  nuqtalar aylanani ikki qismga ajratyapti. Bu qismlarning har biri *aylana yoyi*,  $A$  va  $B$  nuqtalar esa *yoyning uchlari* deb ataladi.



### Savollarga javob bering!

1. Sirkul yordamida aylana qanday chiziladi?
2. Qanday shaklga doira deb ataladi?
3. Aylananing radiusi nima?
4. Aylana diametri radiusidan necha marta katta?
5. Aylana yoyi deb nimaga aytiladi?



### Sinfda bajariladigan mashqlar

567. Daftaringizga  $O$  nuqtani belgilang. Uni markaz qilib sirkul yordamida aylana chizing. Chizg'ich bilan aylananing radiusini o'lchang. Bu aylananing diametri nimaga teng?

568. Radiusi: a) 6 sm; b) 4 sm 5 mm bo'lgan aylana chizing. Bu aylananing diametri nimaga teng bo'ladi?

569. Markazi  $O$  nuqtada, radiusi 8 sm bo'lgan doira berilgan. Uning chegarasida  $A$  nuqta, ichki qismida  $B$  nuqta va tashqi qismida  $C$  nuqta belgilangan. Doiraning markazidan  $A$  nuqttagacha bo'lgan masofa  $OA$  kesma uzunligi haqida nima deyish mumkin?  $OB$  kesma haqida-chi?  $OC$  kesma haqida-chi?

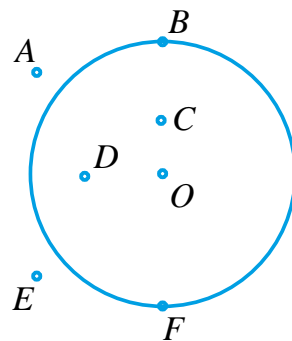

7- rasm

570. Oralaridagi masofa 10 sm bo'lgan  $A$  va  $B$  nuqta berilgan.  $A$  va  $B$  nuqtalarni markaz qilib, radiusi: a) 3 sm; b) 5 sm; d) 7 sm bo'lgan aylanalar chizilgan. Bu aylanalar o'zaro kesishadimi?



### Uyda bajariladigan mashqlar

571. Daftaringizga  $O$  nuqtani belgilang. Uni markaz qilib sirkul yordamida diametri 12 sm bo'lgan aylana chizing.

572. 7- rasmda tasvirlangan nuqtalarning qaysilari aylanada, qaysilari doirada yotadi?

573. Daftaringizga  $O$  nuqtani belgilang. Bir uchi  $O$  nuqtada, uzunligi 3 sm bo'lgan 5 ta kesma chizing. Bu kesmalarning ikkinchi uchi markazi  $O$  nuqtada bo'lgan aylanada yotadi. Bu aylanani chizing va uning diametrini aniqlang.

27- §.

ULUSHLAR. ODDIY KASRLAR HAQIDA TUSHUNCHA

Kundalik turmushda ko'pincha bir butun narsani ulushlarga bo'lishga to'g'ri keladi. Eng ko'p tarqalgan ulushlar bu – yarim va chorakdir.



1- rasm

Yarim kilogramm, chorak soat, yarim litr kabi so'zlarni ko'p eshitgansiz. Lekin matematikada yana boshqa ulushlar ham bor. Hozir shu ulushlar haqida to'xtalamiz.

Ozoda xola nonni teng to'rt bo'lakka ushatib, uning bir bo'lagini nabirasi Hadichaga berdi (1- rasm). Bu teng bo'laklar *ulushlar* deb ataladi.

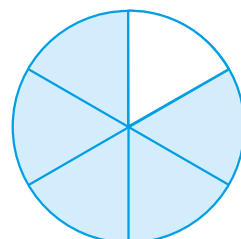

2- rasm

Bu holda Hadichaga nonning «to'rtta ulushidan bittasi» yoki «to'rttdan bir ulushi» tegdi, deb aytamiz.

Agar non ikkita, uchta yoki beshta teng bo'laklarga bo'linsa, mos ravishda, ikkidan bir, uchdan bir va beshdan bir deb ataluvchi ulushlar hosil bo'ladi.

Sakkizdan bir ulush – *nimchorak*, to'rttdan bir ulush – *chorak*, ikkidan bir ulush esa *yarim* deb ham ataladi.

Doira 6 ta teng bo'lakka bo'lingan (2- rasm). Har bir bo'lak uning oltidan bir ulushini tashkil qiladi. 2- rasmda oltita ulushdan beshtasi bo'yalgan. Bu beshta ulush — doiraning oltidan besh qismi deb ataladi.

Doiraning oltidan besh qismi —  $\frac{5}{6}$  ko'rinishda ifodalanadi va «oltidan besh» deb o'qiladi.

$\frac{a}{b}$  ko'rinishidagi yozuvlar *oddiy kasrlar* deb ataladi.

Kasr ifodasidagi  $a$  soni *kasrning surati*,  $b$  soni esa *kasrning maxraji* deb ataladi. Kasrning maxraji pastda, surati esa tepada yoziladi va ular kasr chizig'i bilan ajratib qo'yiladi.

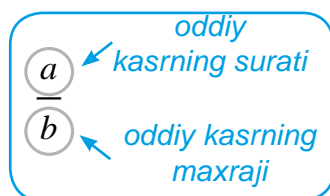

*Kasrning maxraji – butun nechta ulushga bo'linganini, surati esa bu ulushlardan nechtasi olinganini bildiradi.*



Kasrlarni sonlar nurida ham tasvirlash mumkin. Masalan,  $\frac{1}{5}$  kasrni sonlar nurida tasvirlaylik. Buning uchun sonlar nurida birlik kesma olamiz va uni 5 ta teng kesmalarga ajratamiz (3- rasm). U holda,  $OA$  kesma birlik kesmaning beshdan bir qismini tashkil qiladi va  $A$  nuqtaning koordinatasi  $\frac{1}{5}$  ga teng bo'ladi:  $A (\frac{1}{5})$ .

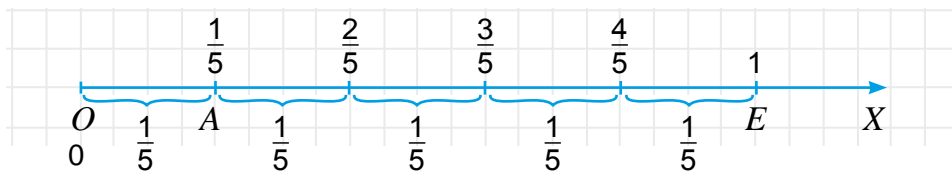

3- rasm



Biror  $m$  sonining (miqdorning)  $\frac{a}{b}$  qismini topish uchun  $m$  sonini  $b$  ga bo'lib,  $a$  ga ko'paytirish kifoya .

**1- misol.** Uzunligi 240 m bo'lgan simning  $\frac{5}{6}$  qismi qirqib olindi (4- rasm). Necha metr qirqib olingan?

**Yechish.** Simning  $\frac{1}{6}$  ulushi  $240 : 6 = 40$  (m) ni tashkil qiladi.

Bu ulushlarning beshtasi  $40 \cdot 5 = 200$  (m) ga teng bo'ladi,

**Javob:** 200 m sim qirqib olingan.

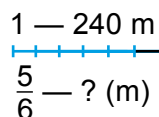

4- rasm

**2- misol.** Qishloqdan shahargacha bo'lgan masofa 9 km. Komil bu yo'ning 5 kilometrini bosib o'tdi (5- rasm). Komil butun yo'ning qanday qismini bosib o'tgan?

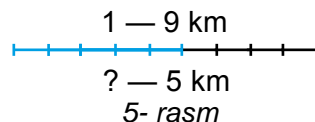

5- rasm

**Yechish.** Butun yo'l — 9 km. Uning  $\frac{1}{9}$  ulushi, ya'ni butun yo'lni 9 ta teng bo'lakka bo'lib, uning bitta ulushini olsak, 1 km ga teng bo'ladi. Unda 5 km — butun yo'ning  $\frac{5}{9}$  qismini tashkil qiladi.

**Javob:** Komil butun yo'ning  $\frac{5}{9}$  qismini bosib o'tgan.



$\frac{a}{b}$  kasr —  $a$  soni  $b$  sonining qanday qismini tashkil qilishini ko'rsatadi.

O'lchov birliklarining kelib chiqishi ham ulushlar bilan bog'liq.

Uzunligi 1 m bo'lgan kesma 10 ta teng bo'lakka bo'linsa, uning o'ndan bir ulushidan iborat detsimetr hosil bo'ladi. Demak,  $1\text{dm} = \frac{1}{10}\text{m}$ , ya'ni 1 dm metrnig o'ndan bir ulushidan iborat.

Xuddi shunga o'xshash,  $1\text{sm} = \frac{1}{100}\text{m}$  va  $1\text{mm} = \frac{1}{1000}\text{m}$  ekanligini ham aniqlash mumkin. Shu tariqa, kasrlar yordamida kichik o'lchov birliklari katta o'lchov birliklari orqali ifodalanadi.

1 kg = 1000 g bo'lgani uchun,  $1\text{g} = \frac{1}{1000}\text{kg}$ , ya'ni 1 gramm kilogrammning mingdan bir ulushiga teng.



1 t = 1 000 000 g bo'lgani uchun,  $1g = \frac{1}{1\,000\,000} t$ , ya'ni 1 gramm tonnaning milliondan bir ulushini tashkil qiladi.

### Savollarga javob bering!



1. Ulush deb nimaga aytiladi?
2.  $\frac{a}{b}$  yozuv qanday nomlanadi?  $a$  nima deb ataladi?  $b$ -chi?
3. Kasrning maxraji nimani anglatadi? Surati-chi?

### Sinfda bajariladigan mashqlar



**574.** 6- rasmda tasvirlangan shakllar teng bo'laklarga bo'lindi. Bu bo'laklarning har biri butun shaklning qanday ulushini tashkil qiladi?

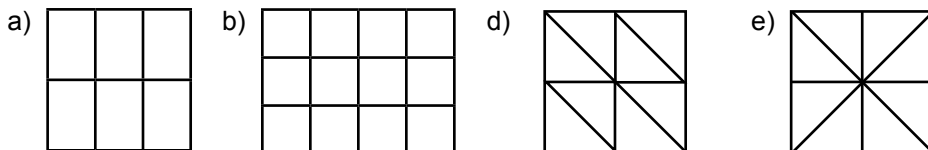

6- rasm

**575.** 7- rasmdagi shakllarning qanday qismi bo'yalgan, qanday qismi bo'yalmagan?

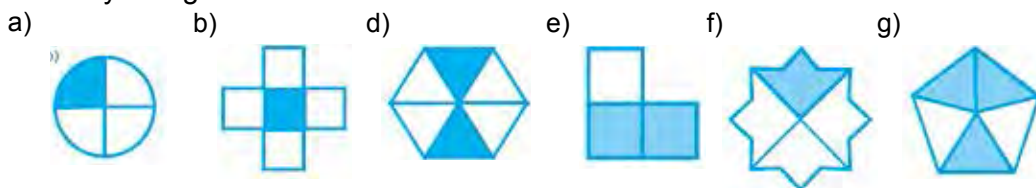

7- rasm

**576.** 8- rasmda tasvirlangan shakllarning qanday qismi bo'yalgan?

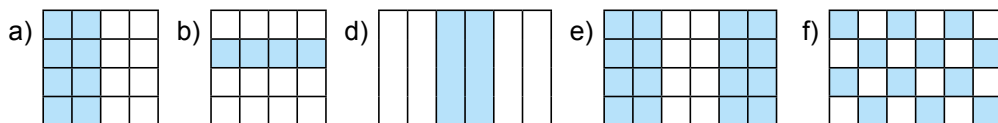

8- rasm

**577.** Daftaringizga tomoni 8 ta katak uzunligiga teng bo'lgan kvadrat chizing. Uni 4 ta teng bo'lakka bo'ling. Kvadratning to'rtidan bir qismini qizil rangga, yarmini ko'k rangga bo'yang. Kvadratning qanday qismi bo'yalmay qoldi?

**578.** Qog'ozga doira chizing va uni qirqib oling. Uni biror diametri bo'ylab buklab ikkita teng bo'lakka bo'ling. Bu bo'laklarning har biri qanday nomlanadi? Har bir bo'lakni buklab, yana teng ikkiga bo'ling. Hosil bo'lgan bo'lakchalar qanday nomlanadi? Bu bo'lakchalarning har birini buklab yana teng ikki bo'lakka bo'ling. Oxirida hosil bo'lgan kichik bo'lakchalar doiraning qanday ulushini tashkil qiladi?

579. a) Yarim; b) chorak; d) nimchorak; e) beshdan bir; f) yuzdan bir; g) yuzdan sakson ikki metrda necha santimetr bor?
580. Fermer xo'jaligida 270 t paxta hosilining  $\frac{7}{9}$  qismi terildi. Qancha paxta terilgan?



*Namuna:* Yuqorida ko'rilgan 1- misol.

581. Ulushlarni oddiy kasr ko'rinishida ifodalang:  
a) ikkidan bir; b) uchdan bir; d) beshdan bir; e) sakkizdan bir.
582. Oddiy kasrlarni o'qing. Kasrning maxraji va suratini ayting va ularning nimani anglatishini tushuntirib bering.

$$\frac{3}{7}; \frac{4}{5}; \frac{5}{6}; \frac{3}{8}; \frac{13}{15}; \frac{5}{9}; \frac{7}{31}; \frac{9}{56}; \frac{47}{112}.$$

583. a) 15 ning  $\frac{3}{5}$  qismini; b) 219 ning  $\frac{2}{3}$  qismini; d) 1035 ning  $\frac{7}{9}$  qismini toping.
584. a) 114 soni 513 ning; b) 1012 soni 6223 ning qanday qismini tashkil qiladi?
585. Hovuz 7 soatda suv bilan to'ladi. a) 1 soat; b) 3 soat; d) 5 soatdan keyin uning qanday qismi suv bilan to'ladi?

*Namuna:* Yuqorida ko'rilgan 3- misol.

586. Kombayn 12 kunda daladagi hosilni o'rib oldi. a) 1 kunda; b) 3 kunda; d) 5 kunda; e) 7 kunda dalaning qanday qismidagi hosil yig'ib olingan?
587. Daftarning 20 katagi uzunligini 1 km deb olib, uzunligi: a)  $\frac{2}{5}$  km; b)  $\frac{3}{5}$  km; d)  $\frac{3}{4}$  km bo'lgan kesmani chizing.



### Uyda bajariladigan mashqlar

588. 9- rasmdagi shakllarning qanday qismi bo'yalgan va qanday qismi bo'yalmagan?

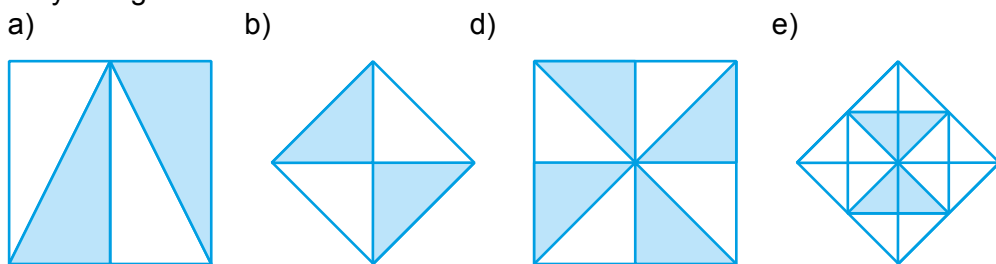

9- rasm

589. a) Yarim; b) chorak; d) uchdan bir; e) oltmishdan bir soatda necha minut bor?
590. Aziza 320 betlik kitobning sakkizdan uch qismini o'qidi. U kitobning hecha betini o'qigan? Kitobning yana necha beti hali o'qilmagan?
591. Ozoda xola 20 ta quymoq pishirdi. Aziza quymoqlarning o'ndan uch qismini, Nargiza o'ndan to'rt qismini, Dilnoza o'ndan bir qismini yedi. Qancha quymoq qoldi?



592. 10- rasmdagi tortning massasi 2450 g bo'lib, u rasmda ko'rsatilgandek ikki bo'lakka bo'lindi. Tortning har bir bo'lagi massasini aniqlang.



10- rasm

a)



b)



11- rasm

593. Oddiy kasr ko'rinishida ifodalang:

a) uchdan bir; || b) oltidan besh; || d) beshdan uch; || e) to'rttdan bir.

594. Daftarning 20 katagi uzunligini birlik kesma deb olib uzunligi a)  $\frac{3}{10}$ ; b)  $\frac{7}{10}$ ; d)  $\frac{4}{5}$ ; e)  $\frac{9}{10}$  ga teng bo'lgan kesmani chizing.

595. a) 323 ning  $\frac{5}{17}$  qismini; b) 1820 ning  $\frac{13}{28}$  qismini toping.

596. a) 31 soni 56 ning; b) 112 soni 259 ning qanday qismini tashkil qiladi?

597. 11- rasmdagi butun tort massasi 1260 g bo'lsa, uning qanchasi qolgan?

### Qiziqarli matematikaga oid masalalar



#### Qalbaki tangani aniqlash

1. Uchta tangadan bittasi qalbaki. U boshqa tangalardan yengil. Toshsiz pallali tarozida bir marta tortish orqali qalbaki tangani qanday aniqlasa bo'ladi?

Tarozining har bir pallasiga bittadan tangani qo'yamiz. Uchinchi tangani bir chetga olib qo'yamiz. Tangalarni tortishda 2 hol bo'lishi mumkin:

- 1- hol. Tarozni pallalariga qo'yilgan tangalar bir xil og'irlikka ega (a- rasm);  
2- hol. Tarozining bir pallasiga qo'yilgan tanga yengil (b- rasm).

a)



b)



1- holda qaysi tanga qalbaki? 2- holda-chi?

2. 9 ta tanganing bittasi qalbaki. U boshqa tangalardan yengil. Toshsiz pallali tarozida ikki marta tortish orqali qalbaki tangani qanday aniqlasa bo'ladi?  
3. 27 ta tanganing bittasi qalbaki. U boshqa tangalardan yengil. Toshsiz pallali tarozida eng kamida necha marta tortish orqali qalbaki tangani aniqlasa bo'ladi?

28- §

KASRLARNI TAQQOSLASH

Yana o'sha oldingi darsda ko'rilgan masalaga qaytamiz (1- rasm). Endi Ozoda xola nonni teng to'rtta bo'lakka bo'lib, nabirasi Hadichaga ikkitasini bergan bo'lsin. Lekin bu ikki bo'lak birgalikda nonning yarmini tashkil qiladi.

Demak, nonning  $\frac{2}{4}$  qismi va  $\frac{1}{2}$  qismi o'zaro teng bo'ladi. Bu holda  $\frac{2}{4}$  va  $\frac{1}{2}$  kasrlar teng deyiladi va  $\frac{2}{4} = \frac{1}{2}$  tarzda yoziladi (2- rasm).



1- rasm



2- rasm



Ikkita teng kasrlar bitta kasr sonning turli xil ifodasidan iborat.

To'g'ri to'rtburchak 5 ta teng bo'lakka bo'lindi. Bu bo'laklarning 3 tasi bo'yaldi (3- rasm). Natijada to'g'ri to'rtburchakning  $\frac{3}{5}$  qismi bo'yaldi, uning  $\frac{2}{5}$  qismi esa bo'yalmadi.

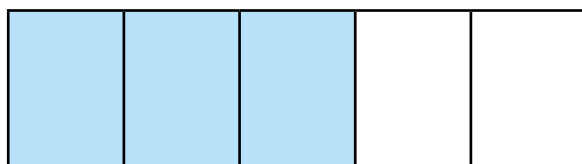

3- rasm

Ko'rib turganingizdek, to'g'ri to'rtburchakning bo'yalgan qismi bo'yalmagan qismidan katta.

Demak,  $\frac{3}{5} > \frac{2}{5}$  bo'ladi.



Bir xil maxrajli ikki kasrdan qaysisining surati kichik (katta) bo'lsa, o'sha kasr kichik (katta) bo'ladi.

Sonlar nurida ikki kasrning qaysi biri ikkinchisiga nisbatan chapda (o'ngda) yotgan bo'lsa, o'sha kasr kichik (katta) bo'ladi.

Haqiqatan, 4- rasmda  $A(\frac{2}{5})$  nuqta  $B(\frac{3}{5})$  nuqtadan chapda yotibdi. Shuning uchun  $\frac{2}{5} < \frac{3}{5}$ .

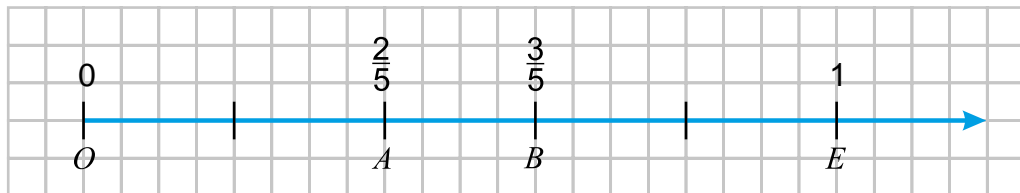

4- rasm

**1- misol.** Poyezd 420 km yo'l yurib, butun yo'lining  $\frac{2}{3}$  qismini bosib o'tdi. Butun yo'l necha km?

**Yechish.** Shartga ko'ra, 420 km butun yo'lining  $\frac{2}{3}$  qismini, ya'ni ikkita  $\frac{1}{3}$  ulushini tashkil qiladi.

Demak, butun yo'lining  $\frac{1}{3}$  ulushi  $420 : 2 = 210$  (km) ga teng bo'ladi.

Unda butun yo'l  $210 \cdot 3 = 630$  (km) ga teng bo'ladi.

**Javob:** Butun yo'l 630 km.

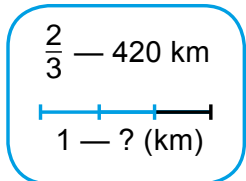

Sonning  $\frac{a}{b}$  qismi  $m$  ga teng bo'lsa, bu sonning o'zini topish uchun  $m$  ni  $b$  ga ko'paytirib,  $a$  ga bo'lish kifoya.



### Savollarga javob bering!



1. Teng kasrlar sonlar nurida qanday tasvirlanadi?
2. Maxraji bir xil bo'lgan kasrlardan qaysi biri katta bo'ladi?
3. Sonlar nurida ikki kasrdan qaysi biri katta yoki kichik ekanligini qanday aniqlasa bo'ladi?

### Sinfda bajariladigan mashqlar



**598.** Quyidagi tenglikni rasm yordamida tushuntiring:

a)  $\frac{1}{4} = \frac{2}{8}$ ;



b)  $\frac{1}{3} = \frac{2}{6}$ .



**599.** Daftaringizga 12 katak uzunligiga teng bo'lgan kesma chizing. Shu kesmadan foydalanib, quyidagi tenglikni izohlang:

a)  $\frac{2}{3} = \frac{8}{12}$ ;

b)  $\frac{5}{6} = \frac{10}{12}$ .

**600.** Daftarning 12 katagi uzunligiga teng bo'lgan birlik kesma olib, sonlar nurida koordinatalari  $\frac{1}{4}, \frac{2}{3}, \frac{3}{4}, \frac{3}{12}, \frac{4}{6}, \frac{8}{12}, \frac{3}{6}, \frac{1}{2}$  bo'lgan nuqtalarni belgilang. Ular orasidan teng kasrlarni aniqlang.

**601.** Daftarning 18 katagi uzunligiga teng bo'lgan birlik kesma olib, sonlar nurida koordinatalari  $\frac{1}{2}, \frac{2}{3}, \frac{5}{6}, \frac{4}{9}, \frac{1}{6}, \frac{7}{9}$  bo'lgan nuqtalarni belgilang. Bu nuqtalardan qaysi biri sonlar o'qida eng chapda, qaysi biri eng o'ngda joylashganligini aniqlang.

**602.** Quyidagi kasrlarni: a) kamayish; b) o'sish tartibida joylashtiring.

$$\frac{5}{9}; \frac{4}{9}; \frac{1}{9}; \frac{7}{9}; \frac{8}{9}; \frac{6}{9}; \frac{2}{9}.$$



**603.** Yulduzcha o'rniga tegishli katta (>) yoki kichik (<) belgisini qo'ying:

a)  $\frac{5}{9} * \frac{4}{9}$ ; || b)  $\frac{1}{8} * \frac{7}{8}$ ; || d)  $\frac{2}{5} * \frac{3}{5}$ ; || e)  $\frac{2}{7} * \frac{6}{7}$ .

**601.** Qaysi kasr kichik? Nega?

a)  $\frac{11}{19}$  yoki  $\frac{7}{19}$ ; || b)  $\frac{17}{38}$  yoki  $\frac{23}{38}$ ; || d)  $\frac{4}{51}$  yoki  $\frac{23}{51}$ ; || e)  $\frac{23}{100}$  yoki  $\frac{67}{100}$ .

**605.** a)  $\frac{3}{5}$  qismi 315 ga; b)  $\frac{3}{7}$  qismi 219 ga; d)  $\frac{5}{17}$  qismi 15 ga teng bo'lgan sonni toping.

*Namuna:* Yuqorida ko'rilgan 1- misol.

**606.**  $b$  ning qanday qiymatlarida  $\frac{5}{12}$  kasr  $\frac{b}{12}$  kasrdan katta bo'ladi? Bunday kasrlarning barchasini yozing.

**607.**  $c$  ning qanday qiymatlarida  $\frac{c}{17}$  kasr  $\frac{6}{17}$  kasrdan katta, lekin  $\frac{13}{17}$  kasrdan kichik bo'ladi? Bunday kasrlarning barchasini yozing.

**608.** Ishchi 24 ta detal tayyorladi. Bu kunlik rejaning  $\frac{3}{8}$  qismini tashkil qiladi. Ishchi bir kunda reja bo'yicha nechta detal tayyorlashi kerak?

*Namuna:* Yuqorida ko'rilgan 1- misol.

**609.** Daftaringizga sonlar nurini chizing. Unda 18 katak uzunligiga teng bo'lgan birlik kesma olib,  $A(\frac{2}{9})$  va  $B(\frac{4}{18})$  nuqtalarni belgilang va xulosa chiqaring.



### Uyda bajariladigan mashqlar

**610.** Daftaringizga sonlar nurini chizing. Unda 18 katak uzunligiga teng bo'lgan birlik kesma olib, koordinatalari  $\frac{2}{3}, \frac{3}{18}, \frac{4}{6}, \frac{6}{18}, \frac{1}{6}, \frac{1}{3}, \frac{3}{9}$  bo'lgan nuqtalarni belgilang. Ular orasidan teng kasrlarni aniqlang.

611. 606- masalada berilgan kasrlarni a) kamayish; b) o'sish tartibida joylashtiring.

612. Yulduzcha o'rniga tegishli katta (>) yoki kichik (<) belgisini qo'ying:

a)  $\frac{5}{11} * \frac{8}{11}$ ; || b)  $\frac{9}{13} * \frac{7}{13}$ ; || d)  $\frac{7}{15} * \frac{2}{15}$ ; || e)  $\frac{23}{31} * \frac{6}{31}$ .



613. 4- rasmda tasvirlangan shakillarning qanday qismi bo'yalgan?

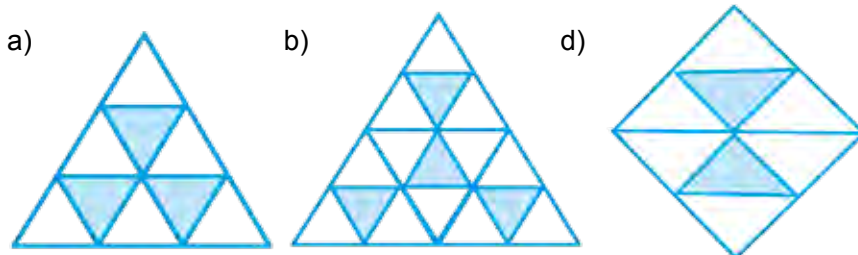

5- rasm

614. Qaysi kasr katta? Nega?

a)  $\frac{8}{11}$  yoki  $\frac{7}{11}$ ; || b)  $\frac{17}{28}$  yoki  $\frac{13}{28}$ ; || d)  $\frac{237}{1000}$  yoki  $\frac{367}{1000}$ .

615. a)  $\frac{7}{9}$  qismi 21 ga; b)  $\frac{5}{13}$  qismi 65 ga teng bo'lgan sonni toping.

616.  $c$  ning qanday qiymatlarida  $\frac{c}{13}$  kasr  $\frac{4}{13}$  kasrdan katta, lekin  $\frac{10}{13}$  kasrdan kichik bo'ladi? Bunday kasrlarning barchasini yozing.

### Qiziqarli matematikaga oid masalalar



Sotuvchi pichoq bilan uch marta kesib pishloqni 8 ta bo'lakka bo'ldi. Buni u qanday amalga oshirgan?

### Matematika tarixiga oid lavhalar



Qadimda yerni o'lchash ishlari muhim ahamiyat kasb etgan. Aynan yerni o'lchashga bo'lgan inson ehtiyojlari sabab matematikaning ajoyib bo'limi – geometriya fani vujudga kelgan. «Geometriya» atamasining «yer o'lchayman» degan lug'aviy ma'nosi ham buni tasdiqlab turibdi.



Matematika, xususan, geometriya ilmidan yaxshi xabardor bo'lgan buyuk vatandoshimiz Ahmad al-Farg'oniy Misrda Nil daryosi suvi sig'imini va chuqurligini o'lchaydigan inshoot qurilishiga rahbarlik qilgan. Bu inshoot hozirda ham Qohira shahrida yaxshi saqlanib qolgan.

29- §

TO'G'RI VA NOTO'G'RI KASRLAR

Shokolad plitkasi 12 ta bo'lakdan (o'n ikkidan bir ulushdan) iborat (1.a-rasm). Uning 5 bo'lagi sindirib olinib, likopchaga qo'yildi. Natijada, likopchaga shokoladning  $\frac{5}{12}$  qismi qo'yilgan bo'ladi (1.b-rasm).

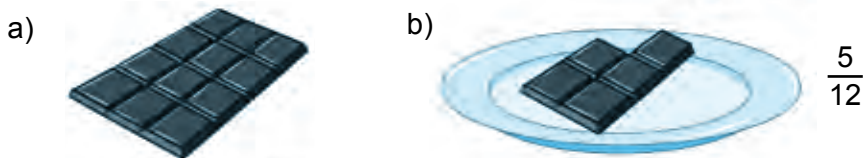

1- rasm

Agar likopchaga shokoladning hamma – 12 ta bo'lagi qo'yilganda edi, likopchaga shokoladning  $\frac{12}{12}$  qismi, ya'ni hammasi qo'yilgan bo'lar edi (2.b-rasm).

Demak,  $\frac{12}{12} = 1$  ekan.

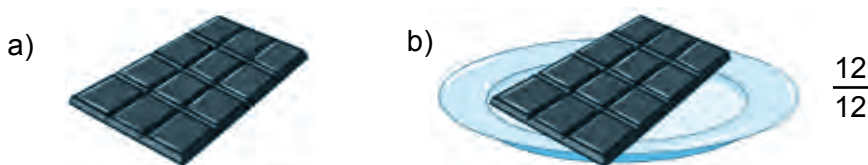

2- rasm

Endi 2 ta shokolad plitkasini olamiz (3.a-rasm). Likopchaga 17 ta shokolad bo'lagini qo'yamiz. Unda likopchaga shokoladning  $\frac{17}{12}$  qismi qo'yilgan bo'ladi (3.b-rasm).



3- rasm

$\frac{5}{12}$  kasrning surati maxrajidan kichik.

Surati maxrajidan kichik kasrlar *to'g'ri kasrlar* deb ataladi.

$\frac{12}{12}$  kasrning surati maxrajiga teng,  $\frac{17}{12}$  kasrning esa surati maxrajidan katta.

Surati maxrajidan katta yoki unga teng bo'lgan kasrlar *noto'g'ri kasrlar* deb ataladi.



To'g'ri kasrlar 1 dan kichik bo'ladi. Noto'g'ri kasrlar esa 1 dan katta yoki 1 ga teng bo'ladi.



## Savollarga javob bering!



1. Qanday kasr to'g'ri kasr deb ataladi?
2. Kasrning noto'g'ri kasr ekanligini qanday aniqlasa bo'ladi?
3. Qanday kasrlar 1 dan kichik bo'ladi?
4. Noto'g'ri kasr 1 dan kichik bo'lishi mumkinmi?

## Sinfda bajariladigan mashqlar



- 617.** Quyidagi kasrlardan qaysi biri to'g'ri, qaysi biri noto'g'ri kasr ekanligini aniqlang:

$$\frac{1}{4}; \frac{5}{3}; \frac{3}{4}; \frac{17}{12}; \frac{4}{6}; \frac{8}{8}; \frac{23}{22}; \frac{209}{999}$$

- 618.** Quyidagi kasrlardan qaysi biri: a) 1 dan katta; b) 1 ga teng; d) 1 dan kichik?

$$\frac{5}{9}; \frac{4}{3}; \frac{8}{13}; \frac{17}{9}; \frac{81}{79}; \frac{7}{7}; \frac{2}{9}; \frac{51}{90}; \frac{42}{42}; \frac{1}{19}$$

- 619.** Maxraji 11 bo'lgan: a) 3 ta to'g'ri; b) 3 ta noto'g'ri kasr yozing.

- 620.** Daftaringizga sonlar nurini chizing. Unda 8 katak uzunligiga teng bo'lgan birlik kesma olib, koordinatalari  $\frac{1}{8}, \frac{4}{8}, \frac{5}{8}, \frac{3}{8}, \frac{9}{8}, \frac{11}{8}, \frac{8}{8}, \frac{13}{8}$  bo'lgan nuqtalarni belgilang. Bu kasrlarning qaysilari: a) 1 dan katta; b) 1 ga teng; d) 1 dan kichik?

- 621.** 4- rasmga qarab: a)  $EM$  kesma  $KD$  kesmaning; b)  $KD$  kesma  $EM$  kesmaning qanday qismini tashkil qilishini toping.

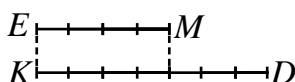

4- rasm

- 622.**  $a$  ning qanday qiymatlarida: a)  $\frac{a}{13}$  to'g'ri kasr; b)  $\frac{15}{a}$  noto'g'ri kasr bo'ladi?

- 623.** a) Yarmi 12 ga; b) choragi 19 ga; d) uchdan ikki qismi 24 ga; e) beshdan uch qismi 45 ga teng bo'lgan sonni toping.



- 624.** 1 kg tonnaning qanday qismini tashkil qiladi? 1 sentner-chi?

- 625.** 1 minut soatning qanday qismini tashkil qiladi? 19 minut-chi? 30 minut-chi? 48 minut-chi?

- 626.** a)  $\frac{1}{4}$ ; b)  $\frac{3}{4}$ ; d)  $\frac{3}{10}$ ; e)  $\frac{13}{10}$  tonnada necha kilogramm bor?

- 627.** a)  $\frac{2}{5}$ ; b)  $\frac{3}{5}$ ; d)  $\frac{7}{10}$ ; e)  $\frac{9}{2}$  soatda necha minut bor?

- 628.** 1 kg bo'yoq bilan  $7 \text{ m}^2$  yuzani bo'yash mumkin.  $4 \text{ m}^2, 9 \text{ m}^2, 18 \text{ m}^2$  yuzani bo'yash uchun qancha bo'yoq kerak bo'ladi?

629. a)  $\frac{1}{3}$  qismi 18 ga; b)  $\frac{1}{6}$  qismi 12 ga; d)  $\frac{1}{12}$  qismi 4 ga teng bo'lgan sonni toping.
630. Sayyoh 24 km yo'lni 2 kunda bosib o'tishi kerak edi. Lekin u birinchi kuni butun yo'lning  $\frac{7}{12}$  qismini bosib o'tdi. Sayyoh ikkinchi kuni yana necha kilometr yo'l bosishi kerak?



### Uyda bajariladigan mashqlar

631. Surati 7 bo'lgan: a) 3 ta to'g'ri; b) 3 ta noto'g'ri kasr yozing.
632. Shaxmat taxtasining qanday qismi qora rangga bo'yalgan?
633. 5- rasmga qarab: a)  $AB$  kesma  $CD$  kesmaning; b)  $CD$  kesma  $AB$  kesmaning qanday qismini tashkil qilishini toping.

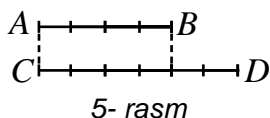

634.  $a$  ning qanday qiymatlarida: a)  $\frac{a}{8}$  to'g'ri kasr; b)  $\frac{21}{a}$  noto'g'ri kasr bo'ladi?

635. a)  $\frac{2}{3}$ ; b)  $\frac{3}{12}$ ; d)  $\frac{24}{15}$  soatda necha minut bor?
636. Ertalabki soat 7 da sutkaning qanday qismi o'tgan bo'ladi?
637. a)  $\frac{2}{3}$  qismi 24 ga; b)  $\frac{3}{5}$  qismi 9 ga teng bo'lgan sonni toping.
638. Sayyoh 27 km yo'l bosdi. Bu butun yo'lning  $\frac{3}{5}$  qismini tashkil qiladi. Sayyoh manzilga yetib borishi uchun yana necha kilometr yo'l bosishi kerak?



### Bilimingizni sinab ko'ring!

#### 7- nazorat ishi namunasi

- Daftarning 8 ta katagi uzunligini birlik kesma deb olib, sonlar nurida  $A(\frac{3}{8})$ ,  $B(\frac{1}{2})$ ,  $C(\frac{7}{8})$ ,  $D(\frac{1}{4})$ ,  $E(\frac{11}{8})$  nuqtalarni belgilang.
- Sonlarni taqqoslang: a)  $\frac{5}{13}$  va  $\frac{7}{13}$ ; b) 1 va  $\frac{7}{6}$ ; d)  $\frac{11}{15}$  va  $\frac{8}{15}$ ; e)  $\frac{8}{9}$  va  $\frac{16}{18}$ .
- 30 ning  $\frac{3}{5}$  qismini 14 ning  $\frac{2}{7}$  qismiga qo'shing.
- a)  $9 \text{ sm}^2$  detsimetr kvadratning; b)  $17 \text{ dm}^3$  metr kubning; d) 13 kg sentnerning qanday qismini tashkil qiladi?
- To'g'ri to'rtburchakning eni 48 sm bo'lib, u perimetrining  $\frac{3}{16}$  qismini tashkil qiladi. To'g'ri to'rtburchakning bo'yini toping.

30- §

BIR XIL MAXRAJLI KASRLARNI QO'SHISH VA AYIRISH

Kasr sonlarni natural sonlar singari qo'shish, ayirish, ko'paytirish va bo'lish mumkin. 6- sinfda kasrlar ustida ixtiyoriy amallarni bajarishni o'rganasiz. Hozircha bir xil maxrajli kasrlarni qo'shish va ayirish ustida to'xtalamiz.

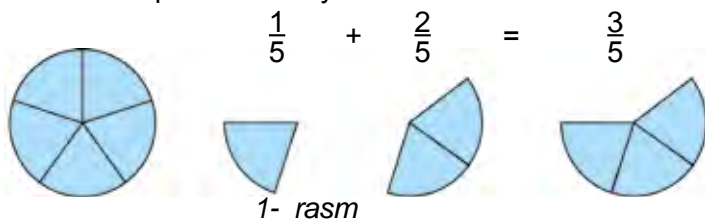

1- rasm

1- rasmda doira 5 ta teng bo'lakka bo'lingan. Doira bo'laklarining bittasi ( $\frac{1}{5}$  qismi) olinib, unga bu bo'laklarning ikkitasi ( $\frac{2}{5}$  qismi) qo'shilsa, doiraning uchta bo'lagi ( $\frac{3}{5}$  qismi) hosil bo'ladi. Bu quyidagicha yoziladi:

$$\frac{1}{5} + \frac{2}{5} = \frac{1+2}{5} = \frac{3}{5} .$$

Bir xil maxrajli kasrlarni qo'shishda, qo'shiluvchilarning suratlari qo'shilib, natija yig'indining suratiga, maxraji esa o'zgarishsiz qoldirilib, yig'indining maxrajiga yoziladi.



Bu qoida harflar yordamida quyidagicha yoziladi:  $\frac{a}{b} + \frac{c}{b} = \frac{a+c}{b} .$

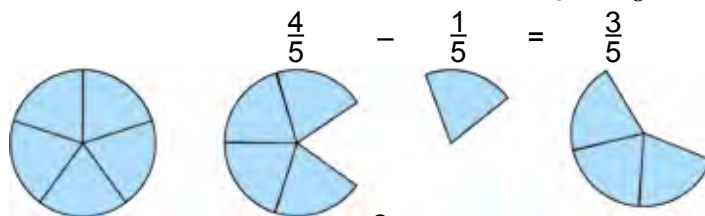

2- rasm

2-rasmda doira bo'laklarining to'rttasi ( $\frac{4}{5}$  qismi) olinib, undan bu bo'laklarning bittasi ( $\frac{1}{5}$  qismi) ayrilsa, doiraning uchta bo'lagi ( $\frac{3}{5}$  qismi) qoladi. Bu quyidagicha yoziladi:

$$\frac{4}{5} - \frac{1}{5} = \frac{4-1}{5} = \frac{3}{5}$$

Bir xil maxrajli kasrlarni ayirishda, kamayuvchining suratidan ayiriluvchining surati ayrilib, natijani ayirmaning suratiga, maxraj esa o'zgarishsiz qoldirilib, ayirmaning maxrajiga yoziladi



Bu qoida harflar yordamida quyidagicha yoziladi:  $\frac{a}{b} - \frac{c}{b} = \frac{a-c}{b} .$

Kasrlarni qo'shish va ayirishni sonlar nuri yordamida ham tushuntirish mumkin.

3- rasmda  $OA$  va  $AB$  kesmalarni sonlar nurida qo'shish tasvirlangan.

Rasmga ko'ra  $OA$  kesma uzunligi  $\frac{3}{7}$  ga,  $AB$  kesma uzunligi  $\frac{2}{7}$  ga teng.  $OB$  kesmaning uzunligi esa  $\frac{5}{7}$  ga teng. Ma'lumki,  $OB = OA + AB$ .

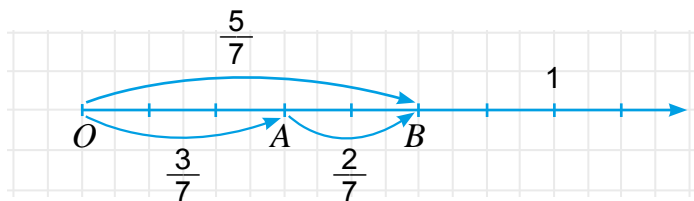

3- rasm

Demak,  $\frac{5}{7}$  kasr  $\frac{3}{7}$  va  $\frac{2}{7}$  kasrlarining yig'indisidan iborat bo'ladi va bu  $\frac{3}{7} + \frac{2}{7} = \frac{5}{7}$  ko'rinishida yoziladi.

$$OA = OB - AB \text{ tenglikdan } \frac{5}{7} - \frac{2}{7} = \frac{3}{7},$$

$$AB = OB - OA \text{ tenglikdan esa } \frac{5}{7} - \frac{3}{7} = \frac{2}{7} \text{ ga ega bo'lamiz.}$$

1- misol. Kasrlarni qo'shing:

$$\text{a) } \frac{3}{10} + \frac{4}{10} = \frac{3+4}{10} = \frac{7}{10}$$

$$\text{b) } \frac{5}{11} + \frac{2}{11} + \frac{3}{11} = \frac{5+2+3}{11} = \frac{10}{11}$$

2- misol. Kasrlarni ayiring:

$$\text{a) } \frac{5}{9} - \frac{1}{9} = \frac{5-1}{9} = \frac{4}{9}$$

$$\text{b) } \frac{9}{17} - \frac{4}{17} = \frac{9-4}{17} = \frac{5}{17}$$



### Savollarga javob bering!

1. Bir xil maxrajli kasrlar qanday qo'shiladi?
2. Bir xil maxrajli kasrlar qanday ayiriladi?
3. Bir xil maxrajli kasrlarni qo'shishni sonlar nurida tushuntiring.



### Sinfda bajariladigan mashqlar

639. Kasrlar ustida amallarni bajaring:

$$\begin{array}{llll} \text{a) } \frac{3}{5} + \frac{4}{5}; & \text{b) } \frac{3}{12} + \frac{4}{12}; & \text{d) } \frac{13}{25} + \frac{14}{25}; & \text{e) } \frac{8}{19} + \frac{11}{19} + \frac{1}{19}; \\ \text{f) } \frac{5}{7} - \frac{3}{7}; & \text{g) } \frac{9}{13} - \frac{7}{13}; & \text{h) } \frac{46}{125} + \frac{34}{125}; & \text{i) } \frac{118}{219} + \frac{110}{219}. \end{array}$$

640. Massasi  $\frac{4}{15}$  kg bo'lgan pomidorga,  $\frac{7}{15}$  kg bodring va  $\frac{2}{15}$  kg piyoz qo'shib salat tayyorlandi. Salatning massasini toping?

**641.** Ishchilar birinchi kuni buyurtmaning  $\frac{4}{9}$  qismini, ikkinchi kuni esa  $\frac{3}{9}$  qismini bajarishdi. Ikki kunda ishchilar buyurtmaning qancha qismini bajardilar?

**642.** Begzod pulining  $\frac{4}{7}$  qismiga kitob va  $\frac{2}{7}$  qismiga daftar xarid qildi. Begzodda pulning qancha qismi qoldi?

**643.** Idishda  $\frac{5}{7}$  litr eritma bor edi.  $\frac{4}{7}$  litr eritma ishlatilgandan so'ng, unga yana  $\frac{3}{7}$  litr eritma quyildi. Idishda qancha eritma bo'ldi?



**644.** Kasrlar ustida amallarni bajaring:

$$\begin{array}{llll} \text{a) } \frac{2}{9} + \frac{5}{9}; & \text{b) } \frac{13}{17} - \frac{2}{17}; & \text{d) } \frac{5}{9} - \frac{1}{9}; & \text{e) } \frac{15}{39} + \frac{13}{39}; \\ \text{f) } \frac{1}{7} + \frac{5}{7}; & \text{g) } \frac{27}{100} + \frac{43}{100}; & \text{h) } \frac{100}{101} - \frac{91}{101}; & \text{i) } \frac{657}{1143} + \frac{342}{1143}. \end{array}$$

**645.**  $a$  ning qanday qiymatida tenglik o'rinli bo'ladi?

$$\text{a) } \frac{a}{9} + \frac{5}{9} = \frac{10}{9}; \quad \text{b) } \frac{a}{17} + \frac{2}{17} = \frac{14}{17}; \quad \text{d) } \frac{a}{9} - \frac{1}{9} = \frac{4}{9}; \quad \text{e) } \frac{15}{39} + \frac{a}{39} = \frac{24}{39}.$$

**646.** Agar  $b = \frac{5}{14}; \frac{9}{14}; \frac{13}{14}$  bo'lsa,  $b - \frac{2}{14}$  ifodaning qiymatini toping.

**647.** Malika 14 kunlik qishki ta'tilning 5 kunini buvisinikida, qolgan qismini uyida o'tkazdi. U ta'tilning qanday qismini uyda o'tkazgan?

**648.** Agar 1 kg pistaning  $\frac{1}{5}$  qismini yog' tashkil qilsa, 20 kg pista yog'i olish uchun necha kilogramm pista kerak bo'ladi?

**649.** Agar a)  $a = \frac{3}{13}; b = \frac{7}{13}; c = \frac{5}{13};$  b)  $a = \frac{5}{21}; b = \frac{15}{21}; c = \frac{9}{21};$

d)  $a = \frac{23}{75}; b = \frac{34}{75}; c = \frac{41}{75}$  bo'lsa,  $a + b - c$  ifodaning qiymatini toping.



**650.** 24 nafar o'quvchining 13 nafari a'lochi va 8 nafari yaxshi baholarga o'qiydi. Sinfdagi a'lo va yaxshi baholarga o'qiydigan o'quvchilarning jami o'quvchilar soniga nisbatan ulushini toping?

**651.** 200 gektar ekin maydonining  $\frac{6}{10}$  qismiga kartoshka va  $\frac{3}{10}$  qismiga piyoz ekildi. Necha gektar ekin maydoni bo'sh qoldi?

652. Amallarni bajaring:

$$\begin{array}{lll} \text{a) } \frac{19}{21} - \frac{16}{21} + \frac{7}{21}; & \text{b) } \frac{9}{11} + \frac{8}{11} - \frac{10}{11}; & \text{d) } \frac{100}{101} + \frac{1}{101} - \frac{99}{101}; \\ \text{e) } \frac{19}{34} - \left( \frac{21}{34} - \frac{7}{34} \right); & \text{f) } \frac{39}{45} - \left( \frac{43}{45} - \frac{41}{45} \right); & \text{g) } \frac{198}{233} - \left( \frac{101}{233} + \frac{87}{233} \right). \end{array}$$



653. Agar  $\frac{3}{14} + \frac{8}{14} = \frac{11}{14}$  ekanligi ma'lum bo'lsa, quyidagi tenglamaning ildizini toping:

$$\text{a) } x - \frac{3}{14} = \frac{8}{14}; \quad \text{b) } \frac{11}{14} - y = \frac{8}{14}; \quad \text{d) } z + \frac{3}{14} = \frac{11}{14}; \quad \text{e) } \frac{11}{14} - p = \frac{3}{14}.$$

654. Tenglamani yeching:

$$\text{a) } x - \frac{3}{34} = \frac{5}{34}; \quad \text{b) } \frac{36}{77} - y = \frac{19}{77}; \quad \text{d) } z + \frac{15}{24} = \frac{23}{24}; \quad \text{e) } \frac{14}{87} + p = \frac{80}{87}.$$

655. Bog'dan jami 3 sr 60 kg meva terildi. Mevalarning  $\frac{7}{12}$  qismini olma,  $\frac{4}{12}$  qismini nok va qolganini behi tashkil qiladi. Terilgan olmalar nokdan necha kilogramm ko'p?

656. Kitobning birinchi bo'limi butun kitobning  $\frac{5}{13}$  qismini, ikkinchi bo'limi esa uning  $\frac{2}{13}$  qismini tashkil etadi. Agar birinchi bo'lim ikkinchi bo'limdan 12 bet ko'p bo'lsa, kitob necha betdan iborat?

657. Tenglamani yeching:

$$\text{a) } \frac{17}{35} - x = \frac{8}{35} + \frac{3}{35}; \quad \text{b) } y - \frac{17}{21} = \frac{19}{21} - \frac{16}{21}; \quad \text{d) } z + \frac{35}{49} = \frac{41}{49} + \frac{39}{49}.$$



### Uyda bajariladigan mashqlar

658. Hisoblang:

$$\begin{array}{llll} \text{a) } \frac{1}{8} + \frac{5}{8}; & \text{b) } \frac{5}{9} + \frac{3}{9}; & \text{d) } \frac{13}{21} + \frac{4}{21}; & \text{e) } \frac{8}{27} + \frac{15}{27} + \frac{13}{27}; \\ \text{f) } \frac{5}{12} - \frac{1}{12}; & \text{g) } \frac{11}{23} - \frac{7}{23}; & \text{h) } \frac{360}{500} - \frac{234}{500}; & \text{i) } \frac{68}{100} - \frac{54}{100}. \end{array}$$

659. Yashil bo'yoq hosil qilish uchun massasi  $\frac{7}{12}$  kg bo'lgan sariq bo'yoqqa massasi  $\frac{4}{12}$  kg bo'lgan ko'k bo'yoq qo'shib aralashtirildi. Yashil bo'yoqning massasini toping.

660. Ekilgan 150 ta pomidor ko'chatining 120 tasi unib chiqdi. Ko'chatning qanday qismi unib chiqmagan?

661. Qaymoqning  $\frac{1}{5}$  qismini yog' tashkil qiladi. 20 kg qaymoqda qancha yog' bor?



662. Ikki kunda bog'dagi o'rikning  $\frac{11}{12}$  qismi terildi. Agar birinchi kuni o'rikning  $\frac{5}{12}$  qismi terilgan bo'lsa, ikkinchi kuni jami o'rikning qancha qismi terilgan?

663. Kasrlar ustida amallarni bajaring:

a)  $\frac{3}{7} + \frac{4}{7}$ ;      b)  $\frac{19}{27} + \frac{2}{27}$ ;      d)  $\frac{157}{439} + \frac{213}{439}$ ;  
 e)  $\frac{113}{117} - \frac{75}{117}$ ;      f)  $\frac{234}{2161} - \frac{227}{2161}$ ;      g)  $\frac{1200}{1501} - \frac{912}{1501}$ .

664. Yanvar oyida 11 kun qor, 6 kun yomg'ir yog'di. Oyning qanday qismida havo ochiq bo'lgan?

665. Agar muzqaymoqning  $\frac{4}{5}$  qismini sut tashkil qilsa, 2 kg muzqaymoq tayyorlash uchun qancha sut kerak bo'ladi?



666.  $a$  ning qanday qiymatida tenglik o'rinli bo'ladi?

a)  $\frac{a}{22} + \frac{9}{22} = \frac{34}{22}$ ;      b)  $\frac{a}{47} + \frac{23}{47} = \frac{43}{47}$ ;      d)  $\frac{a}{79} - \frac{17}{79} = \frac{44}{79}$ .

667. Agar  $b = \frac{11}{64}$  bo'lsa,  $b - \frac{9}{64}$  ifodaning qiymatini toping.

668. 130 ar ekin maydonining  $\frac{3}{10}$  qismiga kartoshka va  $\frac{5}{10}$  qismiga piyoz ekildi. Necha ar ekin maydoni bo'sh qoldi?



669. Agar  $\frac{8}{24} + \frac{15}{24} = \frac{23}{24}$  ekanligi ma'lum bo'lsa, quyidagi tenglamani yeching:

a)  $x - \frac{15}{24} = \frac{8}{24}$ ;      b)  $z + \frac{15}{24} = \frac{23}{24}$ ;      d)  $\frac{23}{24} - p = \frac{8}{24}$ .

670. Tenglamani yeching:

a)  $z + \frac{15}{24} = \frac{23}{24}$ ;      b)  $\frac{27}{45} - x = \frac{18}{45} + \frac{3}{45}$ ;      d)  $y - \frac{7}{13} = \frac{12}{13} - \frac{3}{13}$ .

671. Sinfda 30 o'quvchi bor. Matematikadan o'tkazilgan nazorat ishida o'quvchilarning  $\frac{7}{15}$  qismi - «5»,  $\frac{5}{15}$  qismi - «4» va qolgani - «3» baho oldi. Qancha o'quvchi «3» baho olgan?

Shu choqqacha 2 ni 3 ga bo'lib bo'lmaydi, deb kelgan edik. Chunki, har qanday natural sonni 3 ga ko'paytirganda 2 hosil bo'lmaydi. Kasr sonlarning borligini bilib olgandan so'ng, buning iloji topildi. Buni quyidagi masala asosida tushuntirishga harakat qilamiz.

*1- misol.* 2 ta bir xil quymoqni uchta bolaga teng bo'lib bering (1- rasm).

*Yechish.* Buning uchun har bir quymoqni teng 3 bo'lakka bo'lamiz. Natijada 6 ta ulush (ya'ni quymoqning  $\frac{1}{3}$  qismi) hosil bo'ladi. Endi bu ulushlarni uchta bolaga ikkitadan bo'lib bera olamiz.

Shunda, har bir bolaga quymoqning  $\frac{1}{3} + \frac{1}{3} = \frac{2}{3}$  qismi tegadi.  $\frac{2}{3}$  kasr 2 ta quymoqni 3 ta teng bo'lakka bo'lganda hosil bo'ldi.

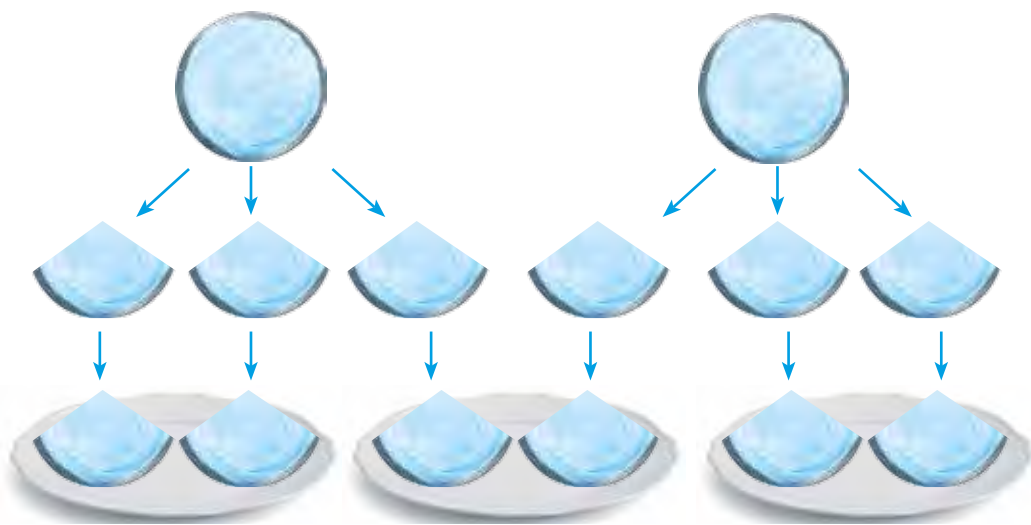

1- rasm

Demak,  $2 : 3 = \frac{2}{3}$  deb yozish mumkin. Shuning uchun kasr chizig'ini bo'lish belgisi deb tushunish mumkin.



Har qanday natural sonlarni bo'lish natijasini kasrlar yordamida ifodalash mumkin.

Agar bo'lish qoldiqsiz bajarilsa, bo'linma natural sondan iborat bo'ladi. Agar bo'lish qoldikli bajarilsa, bo'linma kasr sondan iborat bo'ladi.

Masalan,  $32 : 4 = \frac{32}{4} = 8$ ,  $5 : 1 = \frac{5}{1} = 5$ ,  $4 : 7 = \frac{4}{7}$ ,  $13 : 5 = \frac{13}{5}$ .

*2- misol.* 4 sonini maxraji 6 bo'lgan kasr ko'rinishida ifodalang.



**Yechish.** Buning uchun oldin shunday sonni topishimiz kerakki, uni 6 ga bo'lganda 4 hosil bo'lsin. Bu son – 4 va 6 sonlarining ko'paytmasidan iborat bo'ladi:  $4 \cdot 6 = 24$ .

$$\text{Demak, } 4 = \frac{24}{6}.$$

Umuman olganda, har qanday natural sonni maxraji ixtiyoriy natural son bo'lgan kasr ko'rinishida ifodalash mumkin. Bu kasrning surati berilgan natural son va maxrajining ko'paytmasidan iborat bo'ladi.

Bir xil maxrajli kasrlarni qo'shish qoidasi ifodalangan  $\frac{a}{c} + \frac{b}{c} = \frac{a+b}{c}$  formulani boshqacha  $a : c + b : c = (a + b) : c$  yoki  $(a + b) : c = a : c + b : c$  ko'rinishda yozib olish mumkin.

Oxirgi yozuv yig'indini songa bo'lish qoidasini ifodalaydi:

Yig'indini songa bo'lishda har bir qo'shiluvchilarni alohida-alohida bu songa bo'lib, so'ng hosil bo'lgan bo'linmalarni qo'shish kifoya.



**Masalan:**

$$(1236 + 642 + 18) : 3 = 1236 : 3 + 642 : 3 + 18 : 3 = 412 + 214 + 6 = 632.$$

### Savollarga javob bering!



1. Har qanday natural sonlarni bo'lish natijasini kasr yordamida ifodalash mum-kinmi?
2. Agar bo'lish qoldiqsiz bajarilsa, bo'linma qanday son bo'ladi?
3. Agar bo'lish qoldikli bajarilsa, bo'linma qanday son bo'ladi?
4. Yig'indini songa bo'lish qoidasini yozing va misollarda tushuntiring?

### Sinfda bajariladigan mashqlar



**672.** Bo'linmani oddiy kasr ko'rinishida ifodalang:

- a)  $3 : 7$ ; || b)  $2 : 10$ ; || d)  $14 : 23$ ; || e)  $9 : 1$ ; || f)  $25 : 5$ ; || g)  $87 : 19$ .

**673.** Rasmdan foydalanib, natural sonni kasr ko'rinishida yozing.

a)   $2 = \frac{\quad}{8}$  || b)   $3 = \frac{\quad}{6}$

**674.** Kasrni bo'linma ko'rinishida ifodalang va uning qiymatini toping:

- a)  $\frac{21}{3}$ ; || b)  $\frac{24}{6}$ ; || d)  $\frac{35}{7}$ ; || e)  $\frac{2525}{25}$ .

675. 5 ta bola 4 ta olmani teng taqsimlab olishdi. Ularning har biriga olmaning qanday bo'lagi tegdi?
676. Bir haftada oila 18 ta non iste'mol qildi. Bir kunda oila iste'mol qilgan nonni kasr ko'rinishida ifodalang.
677. 2 ta qatlama 5 ta likopchaga teng qilib taqsimlandi. Har bir likopchaga qo'yilgan qatlamani kasr ko'rinishida ifodalang.
678. Halima 35 minutda 2 km yurdi. U 1 minutda yurgan yo'lni kasr ko'rinishida ifodalang.
679. Poyezd 15 minutda 20 km yo'l bosdi. U 1 minutda bosgan yo'lni kasr ko'rinishida ifodalang.
- 
680. Yig'indini songa bo'lish qoidasiga ko'ra ifodaning qiymatini toping:  
 a)  $(34 + 51) : 17$ ;    b)  $(3434 + 68) : 34$ ;    d)  $156 : 26 + 364 : 26$ ;  
 e)  $(133 + 228) : 19$ ;    f)  $(952 + 3528) : 56$ ;    g)  $1107 : 123 + 1353 : 123$ .
681. Kvadratning perimetri 7 dm. Uning tomonini kasr ko'rinishida ifodalang.
682. To'g'ri burchakli to'rtburchakning yuzi  $19 \text{ sm}^2$ , bir tomoni esa 7 sm. Ikkinchi tomonini kasr ko'rinishida ifodalang.
683. 46 litr sut 5 ta idishga teng qilib quyildi. Har bir idishga quyilgan sutni kasr ko'rinishida ifodalang.
684. 112 m sim 23 ta teng bo'laklarga bo'lindi. Bitta bo'lakning uzunligini kasr ko'rinishida ifodalang.



### Uyda bajariladigan mashqlar

685. Bo'linmani oddiy kasr ko'rinishida ifodalang:  
 a)  $4 : 5$ ;    b)  $7 : 19$ ;    d)  $24 : 80$ ;    e)  $92 : 31$ ;    f)  $102 : 750$ ;    g)  $384 : 3490$ .
686. Kasrni bo'linma ko'rinishida ifodalang va uning qiymatini toping:  
 a)  $\frac{32}{8}$ ;    b)  $\frac{72}{18}$ ;    d)  $\frac{96}{8}$ ;    e)  $\frac{3131}{101}$ .
687. 9 ta bir xil tarvuzning jami massasi 39 kg. Bitta tarvuzning massasini kasr ko'rinishida ifodalang?
688. Velosipedchi 25 minutda 12 km yo'l bosdi. U 1 minutda bosgan yo'lni kasr ko'rinishida ifodalang.
- 
689. Yig'indini songa bo'lish qoidasidan foydalanib ifodaning qiymatini toping:  
 a)  $(204 + 408) : 17$ ;    b)  $(516 + 2193) : 43$ ;    d)  $462 : 33 + 528 : 33$ .
690. Kvadratning perimetri 54 dm. Uning tomonini kasr ko'rinishida ifodalang.
691. To'g'ri burchakli to'rtburchakning yuzi  $232 \text{ sm}^2$ , bir tomoni esa 47 sm. Ikkinchi tomonini kasr ko'rinishida ifodalang.



32- §

ARALASH SONLAR

1- misol. 3 ta olmani ikkita bolaga teng bo'lib bering.

Yechish. Masalani ikki xil usulda yechish mumkin.

1- usul. Har bir olmani 2 ta teng bo'lakka bo'lamiz (1.a- rasm) va har bir bolaga 3 tadan yarimta olma beramiz. Natijada har bir bolaga olmaning  $\frac{3}{2}$  qismi tegadi.

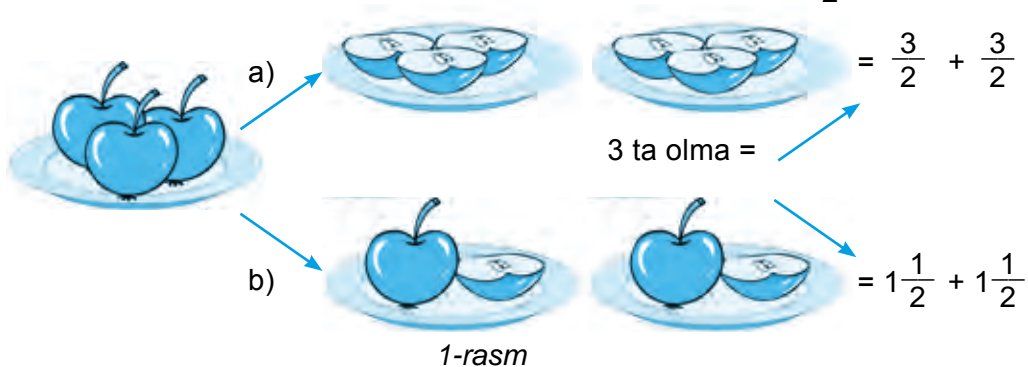

2- usul. Oldin bolalarga bittadan butun olma beramiz. So'ng qolgan bitta olmani 2 bo'lakka bo'lib, har bir bolaga bir bo'lakdan beramiz. Natijada har bir bolaga bitta butun olma va olmaning  $\frac{1}{2}$  qismi, jami olmaning  $1 + \frac{1}{2}$  qismi tegadi (1.b- rasm).

Demak, har ikkala holda ham bolalarga bir xil miqdordagi olma tegadi, ya'ni  $\frac{3}{2} = 1 + \frac{1}{2}$  bo'ladi.

$1 + \frac{1}{2}$  yig'indini qisqaroq  $1\frac{1}{2}$  shaklda yozish qabul qilingan va u «bir butun ikkidan bir» deb o'qiladi.

Shunday qilib,  $\frac{3}{2} = 1\frac{1}{2}$  ifodaga egamiz.

$1\frac{1}{2}$  aralash sonning ifodasi bo'lib, 1 – uning butun qismi,  $\frac{1}{2}$  esa kasr qismi deb yuritiladi.

Butun va kasr qismlari ajratib yozilgan sonlar aralash sonlar deb ataladi.

**32.1. Noto'g'ri kasrni aralash son ko'rinishida ifodalash**

9 ni 4 ga qoldiqli bo'lishni eslaylik (2- rasm):

Bunda 4 – bo'luvchi, 2 – to'liqsiz bo'linma, pastdagi 1 soni esa qoldiq edi.

Demak,  $\frac{9}{4} = 2 + \frac{1}{4} = 2\frac{1}{4}$



2- rasm

Demak, aralash sonning butun qismi to'liqsiz bo'linmadan, kasr qismining maxraji bo'luvchidan, surati esa qoldiqdan iborat bo'lar ekan.

Noto'g'ri kasrni aralash son ko'rinishida ifodalash (ya'ni uning butun qismini ajratish) uchun:

- 1) kasrning surati maxrajiga qoldiqli bo'linadi;
- 2) hosil bo'lgan to'liqsiz bo'linma aralash sonning butun qismi bo'ladi;
- 3) qoldiq (agar u bo'lsa) aralash sonning kasr qismi surati, bo'luvchi esa maxraji bo'ladi.

2- misol.  $\frac{23}{7}$  noto'g'ri kasrning butun qismini ajrating.

*Yechish.* 23 ni 7 ga qoldiqli bo'lamiz. Natijada to'liqsiz bo'linma 3, qoldiq esa 2 ekanligini topamiz (3- rasm).

$$\begin{array}{r} -23 \overline{)7} \leftarrow \text{maxraj} \\ \underline{21} \phantom{0} \phantom{0} \leftarrow \text{butun qism} \\ 2 \phantom{0} \phantom{0} \leftarrow \text{surat} \end{array}$$

3- rasm

Demak,  $\frac{23}{7} = 3 \frac{2}{7}$ .

### 32.2. Aralash sonni noto'g'ri kasr ko'rinishida ifodalash

3- misol.  $2 \frac{3}{5}$  aralash sonni noto'g'ri kasr ko'rinishida ifodalang.

*Yechish.* Ma'lumki,  $2 \frac{3}{5} = 2 + \frac{3}{5}$ . 2 sonini esa maxraji 5 ga teng bo'lgan kasr ko'rinishida ifodalash mumkin:  $2 = \frac{2 \cdot 5}{5} = \frac{10}{5}$ .

Demak,  $2 \frac{3}{5} = 2 + \frac{3}{5} = \frac{10}{5} + \frac{3}{5} = \frac{13}{5}$  (4- rasm).

$$2 \frac{3}{5} = \frac{13}{5}$$

4- rasm

Aralash sonni noto'g'ri kasr ko'rinishida ifodalash uchun:

- 1) sonning butun qismini maxrajiga ko'paytirish;
- 2) hosil bo'lgan ko'paytmaga suratni qo'shish;
- 3) noto'g'ri kasr suratiga hosil bo'lgan yig'indini, maxrajiga esa aralash sonning kasr qismi maxrajini yozish kerak (4- rasm).

Aralash sonni noto'g'ri kasrga aylantirish qoidasini 5-rasm asosida ham tushuntirish mumkin.

$$3 \frac{1}{2} = \frac{1}{2} + \frac{1}{2} + \frac{1}{2} + \frac{1}{2} + \frac{1}{2} + \frac{1}{2} + \frac{1}{2} = \frac{7}{2}$$

5- rasm

**Savollarga javob bering!**



1. Aralash son deb qanday songa aytiladi?
2. Aralash sonning butun va kasr qismi qanday topiladi?
3. Noto'g'ri kasr aralash son ko'rinishida qanday ifodalanadi?
4. Aralash son noto'g'ri kasrga qanday aylantiriladi?

**Sinfda bajariladigan mashqlar**



**692.** Raqamlar bilan yozing:

- a) ikki butun sakkizdan besh; b) olti butun o'n uchdan yetti; d) bir butun yigirma uchdan o'n to'rt; e) sakkiz butun o'ttiz uchdan yigirma ikki.

**693.** Sonni butun va kasr qismlari yig'indisi ko'rinishida ifodalang:

- a)  $2\frac{5}{14}$ ; || b)  $1\frac{3}{4}$ ; || d)  $4\frac{9}{11}$ ; || e)  $12\frac{9}{31}$ ; || f)  $3\frac{18}{44}$ ; || g)  $103\frac{1}{101}$ .

**694.** Shakllarni daftaringizga chizing. Ularni tegishli bo'laklarga bo'ling va tengliklarda tushirib qoldirilgan sonlarni yozing.

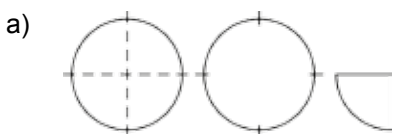

$$2\frac{1}{4} = 2 + \frac{1}{4} = \frac{4}{4} + \frac{1}{4} = \frac{5}{4};$$



$$4\frac{1}{2} = 4 + \frac{1}{2} = \frac{2}{2} + \frac{1}{2} = \frac{3}{2}.$$

**695.** Yig'indini aralash son ko'rinishida ifodalang:

- a)  $4 + \frac{5}{24}$ ; || b)  $5 + \frac{31}{34}$ ; || d)  $14 + \frac{5}{11}$ ; || e)  $42 + \frac{19}{301}$ ; || f)  $23 + \frac{485}{844}$ ; || g)  $143 + \frac{134}{1015}$ .

**696.** Bo'linmani aralash son ko'rinishida ifodalang:

- a)  $23 : 6$ ; || b)  $37 : 11$ ; || d)  $121 : 35$ ; || e)  $56 : 23$ ; || f)  $223 : 126$ .

**697.** Noto'g'ri kasrni aralash songa aylantiring:

- a)  $\frac{77}{14}$ ; || b)  $\frac{37}{24}$ ; || d)  $\frac{89}{11}$ ; || e)  $\frac{94}{31}$ ; || f)  $\frac{180}{44}$ ; || g)  $\frac{1001}{101}$ .

**698.** Rasmdan foydalanib,  $2\frac{3}{5}$  aralash sonni noto'g'ri kasrga aylantiring.

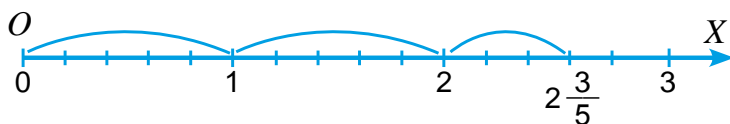

**699.** Sonni noto'g'ri kasr ko'rinishida ifodalang:

- a)  $1\frac{5}{7}$ ; || b)  $3\frac{3}{4}$ ; || d)  $2\frac{9}{15}$ ; || e)  $7\frac{9}{316}$ ; || f)  $12\frac{218}{494}$ ; || g)  $112\frac{451}{1001}$ .

700. Daftaringizga sonlar nurini chizing. Birlik kesma sifatida uzunligi 4 ta katak uzunligiga teng bo'lgan kesmani oling. Sonlar nurida quyidagi sonlarni tasvirlang:

a)  $1\frac{1}{2}$ ;    ||    b)  $2\frac{3}{4}$ ;    ||    d)  $3\frac{1}{4}$ ;    ||    e)  $2\frac{1}{2}$ ;    ||    f)  $2\frac{1}{4}$ ;    ||    g)  $3\frac{1}{2}$ .



701. Qo'shishni bajaring va natijani aralash son ko'rinishida ifodalang:

a)  $\frac{3}{7} + \frac{6}{7}$ ;    ||    b)  $\frac{11}{12} + \frac{4}{12}$ ;    ||    d)  $\frac{11}{13} + \frac{9}{13}$ ;    ||    e)  $\frac{23}{29} + \frac{14}{29}$ ;    ||    f)  $\frac{13}{17} + \frac{11}{17} + \frac{8}{17}$ .

702. Soatlarda ifodalang:

a) 2 soat 34 minut;    ||    b) 4 soat 43 minut;    ||    d) 6 soat 14 minut.

*Namuna:* a) 2 soat 34 minut =  $(2 + \frac{34}{60})$  soat =  $2\frac{34}{60}$  soat.

703. Oila bir haftada 12 kg kartoshka iste'mol qildi. Oila bir kunda o'rtacha necha kilogramm kartoshka iste'mol qilganini toping. Javobni aralash son ko'rinishida ifodalang.

704. Uzunligi  $2\frac{9}{15}$  m bo'lgan sim, har biri  $\frac{1}{15}$  m bo'lgan bo'laklarga bo'lindi. Nechta bo'lak sim hosil bo'ldi?

705. Rasmdan foydalanib, noto'g'ri kasrni aralash son ko'rinishida yozing.



a)  $\frac{7}{2} = 3\frac{1}{2}$ ;

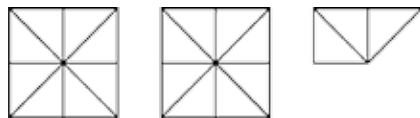

b)  $\frac{19}{8} = \underline{\hspace{2cm}}$ ;

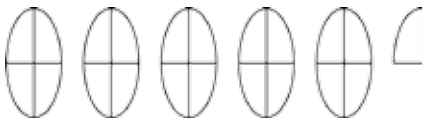

d)  $\frac{21}{4} = \underline{\hspace{2cm}}$ ;

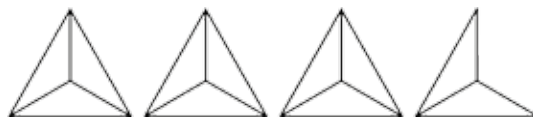

e)  $\frac{11}{3} = \underline{\hspace{2cm}}$ .

706. Olim: «Bo'yim  $\frac{9}{6000}$  km, vaznim esa  $\frac{2}{50}$  tonna», – deb aytdi. U adashmayaptimi?



### Uyda bajariladigan mashqlar

707. Yig'indini aralash son ko'rinishida ifodalang:

a)  $2 + \frac{5}{14}$ ;    ||    b)  $7 + \frac{3}{41}$ ;    ||    d)  $3 + \frac{9}{131}$ ;    ||    e)  $2 + \frac{9}{311}$ .

708. Noto'g'ri kasrni aralash songa aylantiring:

a)  $\frac{56}{17}$ ;    ||    b)  $\frac{77}{34}$ ;    ||    d)  $\frac{99}{12}$ ;    ||    e)  $\frac{394}{86}$ .

709. Sonni noto'g'ri kasr ko'rinishida ifodalang:

a)  $3\frac{5}{8}$ ;    ||    b)  $2\frac{4}{9}$ ;    ||    d)  $12\frac{17}{25}$ ;    ||    e)  $12\frac{55}{87}$ .



710. Qo'shishni bajaring va natijani aralash son ko'rinishida ifodalang:

a)  $\frac{3}{5} + \frac{4}{5}$ ;    ||    b)  $\frac{9}{12} + \frac{14}{12}$ ;    ||    d)  $\frac{7}{8} + \frac{5}{8}$ ;    ||    e)  $\frac{13}{25} + \frac{14}{25}$ ;    ||    f)  $\frac{13}{19} + \frac{11}{19} + \frac{7}{19}$ .

711. Kilometrda ifodalang:

a) 6 km 200 m;    ||    b) 18 km 750 m;    ||    d) 11 km 925 m.

712. Avtomobil 250 km masofani 3 soatda bosib o'tgan bo'lsa, avtomobilning tezligini toping. Javobni aralash son ko'rinishida ifodalang.

713. Ishchi 8 soatda 145 dona detal tayyorladi. U 1 soatda nechta detal tayyorlagan? Javobni aralash son ko'rinishida ifodalang.

### Qiziqarli matematikaga oid masalalar



#### «Kasrli jadval» jumbog'i

«Nollar va xochlar» o'yinini bilsangiz kerak. Unda kvadrat ko'rinishidagi jadvalning biror qatori, ustuni yoki diagonalni bo'yicha faqat «0» yoki «X» belgisi yozilsa, o'yin tugagan bo'ladi. Shu o'yinga o'xshash, «Kasrli jadval» jumbog'ini yeching.

0	X	
X	0	X
0	X	0

Quyida berilgan jadvallardan shunday qator, ustun yoki diagonalni topingki, ularda turgan sonlar yig'indisi jadvalning tepasida yozilgan kasrga teng bo'lsin.

$6\frac{5}{9}$

$\frac{4}{9}$	$5\frac{3}{9}$	4
$4\frac{1}{9}$	$1\frac{4}{9}$	$1\frac{5}{9}$
$2\frac{4}{9}$	$\frac{2}{9}$	$3\frac{8}{9}$

$7\frac{3}{5}$

$4\frac{3}{5}$	$1\frac{3}{5}$	$2\frac{1}{5}$
$3\frac{1}{5}$	$3\frac{4}{5}$	4
$1\frac{3}{5}$	$4\frac{1}{5}$	$\frac{2}{5}$

$8\frac{3}{8}$

$4\frac{1}{8}$	$1\frac{3}{8}$	$1\frac{5}{8}$
$\frac{7}{8}$	$2\frac{6}{8}$	$4\frac{2}{8}$
$2\frac{3}{8}$	$3\frac{7}{8}$	$2\frac{4}{8}$

33- §

ARALASH SONLARNI QO'SHISH VA AYIRISH

Aralash sonlarni qo'shish va ayirish bu amallarning xossalari asosida bajariladi.

1- misol.  $5\frac{2}{7}$  va  $3\frac{1}{7}$  sonlari yig'indisini toping.

Yechish.  $5\frac{2}{7} = 5 + \frac{2}{7}$  va  $3\frac{1}{7} = 3 + \frac{1}{7}$  bo'lgani uchun

$$5\frac{2}{7} + 3\frac{1}{7} = 5 + \frac{2}{7} + 3 + \frac{1}{7} = 5 + 3 + \frac{2}{7} + \frac{1}{7} = 8 + \frac{3}{7} = 8\frac{3}{7}.$$

Bu qisqacha quyidagi ko'rinishda yoziladi:

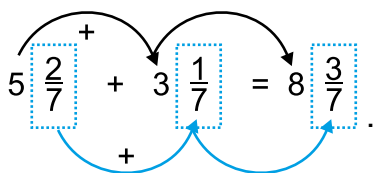

2- misol.  $3\frac{3}{5}$  va  $1\frac{1}{5}$  sonlarning ayirmasini toping.

Yechish.

$$3\frac{3}{5} - 1\frac{1}{5} = 3 + \frac{3}{5} - (1 + \frac{1}{5}) = 3 + \frac{3}{5} - 1 - \frac{1}{5} = (3-1) + (\frac{3}{5} - \frac{1}{5}) = 2 + \frac{2}{5} = 2\frac{2}{5}.$$

Bu qisqacha quyidagi ko'rinishda yoziladi:

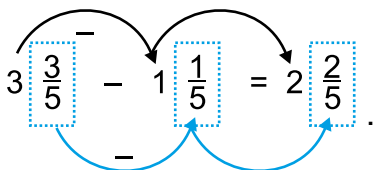

Aralash sonlarni qo'shishda (ayirishda) ularning butun va kasr qismlari alohida-alohida qo'shiladi (ayriladi).

Ba'zida aralash sonlarni qo'shishda kasr qismlar yig'indisi noto'g'ri kasr bo'lishi mumkin. Bunday hollarda noto'g'ri kasrning butun qismi ajratiladi va butun qismlar yig'indisiga qo'shiladi.

3- misol.  $2\frac{5}{7} + 3\frac{4}{7} = 5\frac{9}{7} = 5 + \frac{9}{7} = 5 + 1\frac{2}{7} = 5 + 1 + \frac{2}{7} = 6\frac{2}{7}$

Ba'zida, aralash sonlarni ayirishda kamayuvchining kasr qismi, ayiriluvchining kasr qismidan kichik bo'lishi mumkin. Bunday hollarda 1 butun «maydalanadi».



Buni quyidagi misolda tushuntirish mumkin:

$$4\text{- misol. } 5\frac{2}{9} - 2\frac{4}{9} = (5 + \frac{2}{9}) - 2\frac{4}{9} = (4 + 1 + \frac{2}{9}) - 2\frac{4}{9} = (4 + 1\frac{2}{9}) - 2\frac{4}{9} = (4 + \frac{11}{9}) - 2\frac{4}{9} = 4\frac{11}{9} - 2\frac{4}{9} = 2\frac{7}{9}.$$

Bu qisqaroq  $5\frac{2}{9} - 2\frac{4}{9} = 4\frac{11}{9} - 2\frac{4}{9} = 2\frac{7}{9}$  ko'rinishda yoziladi.

Butun sondan kasr son ayriylotganda ham xuddi shunday yo'l tutiladi, ya'ni 1 butun «maydalanadi».

Buni quyidagi misollarda tushuntirish mumkin:

$$5\text{- misol. } 6 - \frac{3}{7} = 5\frac{7}{7} - \frac{3}{7} = 5\frac{4}{7}; \quad 7 - 2\frac{1}{3} = 6\frac{3}{3} - 2\frac{1}{3} = 4\frac{2}{3}.$$

### Savollarga javob bering!



1. Aralash sonlar qanday qo'shiladi?
2. Aralash sonlarni qo'shishda kasr qismlar yig'indisi noto'g'ri kasr bo'lib qolsa, qanday yo'l tutiladi?
3. Kamayuvchining kasr qismi ayiriluvchidan kichik bo'lganda aralash sonlar qanday bir-biridan ayriladi?
4. Butun qanday «maydalanadi»? Misolda tushuntiring.

### Sinfda bajariladigan mashqlar



**714.** (Og'zaki) Hisoblang va yig'indini qanday topganingizni tushuntiring.

a)  $2\frac{1}{3} + 1;$

b)  $3\frac{2}{3} + 2;$

d)  $4 + 2\frac{2}{5};$

e)  $3\frac{1}{5} + \frac{2}{5};$

f)  $7\frac{1}{4} + \frac{1}{4};$

g)  $4\frac{2}{7} + \frac{3}{7}.$

**715.** Yig'indini toping.

a)  $1\frac{1}{12} + 2\frac{1}{12};$

b)  $3\frac{5}{9} + 1\frac{1}{9};$

d)  $4\frac{2}{9} + 1\frac{1}{9};$

e)  $3\frac{3}{8} + 1\frac{1}{8};$

f)  $4\frac{3}{10} + 6\frac{1}{10};$

g)  $12\frac{1}{15} + 3\frac{4}{15}.$

*Namuna:* Yuqorida yechilgan 1-misol.

**716.** Yig'indini toping va natijani aralash son ko'rinishida tasvirlang:

a)  $\frac{3}{8} + \frac{7}{8};$

b)  $\frac{6}{11} + \frac{8}{11};$

d)  $\frac{2}{3} + \frac{2}{3};$

e)  $\frac{11}{12} + \frac{7}{12}.$

*Namuna:* Yuqorida yechilgan 3-misol.

717. Yig'indini toping.

a)  $3\frac{1}{2} + \frac{1}{2}$ ;    ||    b)  $\frac{3}{4} + 1\frac{1}{4}$ ;    ||    d)  $4\frac{1}{3} + 1\frac{2}{3}$ ;    ||    e)  $2\frac{3}{8} + 3\frac{5}{8}$ .

*Namuna:* Yuqorida yechilgan 3-misol.

718. Yig'indini toping.

a)  $\frac{1}{5} + \frac{2}{5} + 7$ ;    ||    b)  $\frac{1}{8} + 2 + \frac{3}{8}$ ;    ||    d)  $10 + \frac{1}{8} + \frac{3}{8}$ ;    ||    e)  $5\frac{1}{13} + \frac{4}{13} + \frac{5}{13}$ .



719. Yig'indini toping.

a)  $5\frac{4}{5} + 2\frac{2}{5}$ ;    ||    b)  $2\frac{7}{16} + 2\frac{3}{16}$ ;    ||    d)  $10\frac{5}{8} + 1\frac{3}{8}$ ;    ||    e)  $5\frac{3}{5} + 3\frac{4}{5}$ .

*Namuna:* Yuqorida yechilgan 3- misol.

720. (Og'zaki) Ayirmani toping:

a)  $3\frac{1}{2} - 2$ ;    ||    d)  $5\frac{7}{9} - 3$ ;    ||    f)  $6\frac{1}{7} - 1$ ;  
 b)  $5\frac{2}{3} - 4$ ;    ||    e)  $12\frac{1}{4} - 9$ ;    ||    g)  $7\frac{3}{4} - 4$ .

721. (Og'zaki) Butunni «maydalash» usuli bilan ayirmani hisoblang:

a)  $1 - \frac{1}{2}$ ;    ||    b)  $1 - \frac{2}{5}$ ;    ||    d)  $1 - \frac{1}{3}$ ;    ||    e)  $1 - \frac{3}{10}$ ;  
 f)  $1 - \frac{3}{4}$ ;    ||    g)  $1 - \frac{7}{9}$ ;    ||    h)  $1 - \frac{11}{20}$ ;    ||    i)  $1 - \frac{15}{25}$ .

*Namuna:* Yuqorida yechilgan 5- misol.

722. Ayirmani toping:

a)  $3 - \frac{1}{3}$ ;    ||    b)  $6 - \frac{3}{7}$ ;    ||    d)  $4 - \frac{1}{9}$ ;    ||    e)  $8 - \frac{2}{3}$ ;  
 f)  $5 - \frac{2}{5}$ ;    ||    g)  $7 - \frac{5}{8}$ ;    ||    h)  $6 - \frac{1}{3}$ ;    ||    i)  $2 - \frac{5}{6}$ .

*Namuna:* Yuqorida yechilgan 5- misol.

723. Ayirmani toping:

a)  $5 - 2\frac{1}{2}$ ;    ||    b)  $6 - 1\frac{1}{2}$ ;    ||    d)  $6 - 3\frac{2}{5}$ ;    ||    e)  $4 - 2\frac{3}{5}$ ;  
 f)  $7 - 5\frac{3}{7}$ ;    ||    g)  $7 - 1\frac{2}{3}$ ;    ||    h)  $8 - 3\frac{2}{4}$ ;    ||    i)  $4 - 1\frac{1}{6}$ .

*Namuna:* Yuqorida yechilgan 5- misol.

724. Paroxodning turg'un suvdagi tezligi 22 km/soat. Daryo oqimining tezligi esa  $2\frac{2}{3}$  km/soat, paroxodning oqimga qarshi tezligini toping.

725. Do'kondagi 12 tonna kartoshkaning  $7\frac{3}{5}$  tonnasi sotildi. Do'konda qancha kartoshka qoldi?



726. Ayirmani toping:

a)  $5\frac{2}{3} - \frac{1}{3}$ ;

d)  $4\frac{5}{7} - \frac{3}{7}$ ;

f)  $2\frac{3}{5} - \frac{3}{5}$ ;

b)  $7\frac{5}{8} - \frac{1}{8}$ ;

e)  $10\frac{8}{9} - \frac{2}{9}$ ;

g)  $1\frac{3}{4} - \frac{1}{4}$ .

727. Ayirmani toping:

a)  $6\frac{3}{4} - 2\frac{1}{4}$ ;

d)  $3\frac{2}{5} - 1\frac{1}{5}$ ;

f)  $7\frac{3}{5} - \frac{3}{5}$ ;

b)  $4\frac{7}{8} - 2\frac{1}{8}$ ;

e)  $9\frac{2}{11} - 8\frac{1}{11}$ ;

g)  $4\frac{2}{5} - 4\frac{1}{5}$ .

*Namuna:* Yuqorida yechilgan 2- misol.

728. Ayirmani toping:

a)  $1\frac{5}{9} - \frac{8}{9}$ ;

b)  $1\frac{1}{12} - \frac{5}{12}$ ;

d)  $8\frac{3}{7} - 5\frac{5}{7}$ ;

e)  $4\frac{1}{8} - 1\frac{5}{8}$ .

*Namuna:* Yuqorida yechilgan 4- misol.

729. Rasmlarni to'ldiring va ular yordamida ayirmani toping.

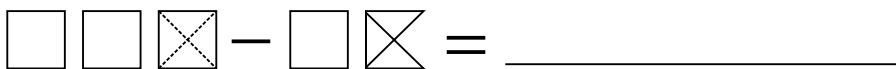

$3 - 1\frac{3}{4} = 2\frac{3}{4} - 1\frac{3}{4} =$  \_\_\_\_\_.

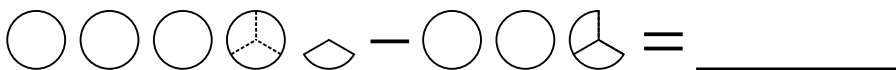

$4\frac{1}{3} - 2\frac{2}{3} = 3\frac{1}{3} - 2\frac{2}{3} =$  \_\_\_\_\_.

730. Daryo oqimining tezligi  $2\frac{3}{4}$  km/soat, qayiqling turg'un suvdagi tezligi esa  $14\frac{1}{4}$  km/soat. Qayiqling oqimga qarshi tezligini toping.

731. To'g'ri to'rtburchakning eni  $12\frac{5}{8}$  sm, bo'yi esa undan  $7\frac{3}{8}$  sm uzun. To'g'ri to'rtburchakning bo'yini toping.

732. Amallarni bajaring:

a)  $5\frac{5}{9} + 2\frac{8}{9}$ ;

d)  $7\frac{1}{12} - 4\frac{5}{12}$ ;

f)  $8\frac{3}{7} + 5\frac{5}{7}$ ;

h)  $4\frac{1}{8} - 1\frac{5}{8}$ ;

b)  $5\frac{5}{9} - \frac{8}{9}$ ;

e)  $7\frac{11}{12} + 4\frac{5}{12}$ ;

g)  $8 - 5\frac{5}{7}$ ;

i)  $6\frac{1}{22} - 2\frac{5}{22}$ .

733. To'g'ri to'rtburchakning eni  $12\frac{5}{8}$  sm, bo'yi esa undan  $7\frac{3}{8}$  uzun. To'g'ri to'rtburchakning bo'yini toping.

734. Rasmdan foydalanib, aralash sonlar ustida amallarni bajaring:

a)  = \_\_\_\_\_  
 $2\frac{1}{4} + 1\frac{2}{4} =$  \_\_\_\_\_

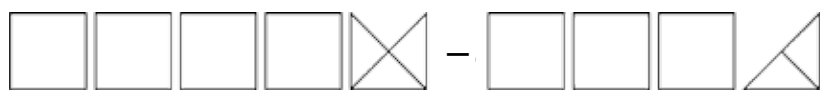
b)  = \_\_\_\_\_  
 $4\frac{3}{4} - 3\frac{2}{4} =$  \_\_\_\_\_

d)  = \_\_\_\_\_  
 $3\frac{5}{6} - \frac{3}{6} =$  \_\_\_\_\_

e)  = \_\_\_\_\_  
 $2\frac{1}{2} + 3 =$  \_\_\_\_\_

735. Ifodaning qiymatini toping:

a)  $5\frac{5}{9} + 2\frac{1}{9} + 1\frac{2}{9}$ ;      d)  $7\frac{1}{3} + 4\frac{1}{3} + \frac{2}{3}$ ;      f)  $8\frac{3}{8} + 5\frac{5}{8} - 2\frac{7}{8}$ ;  
 b)  $8\frac{5}{11} - 3\frac{8}{11} + 4\frac{9}{11}$ ;      e)  $5\frac{11}{21} + 4\frac{5}{21} - 6\frac{7}{21}$ ;      g)  $8\frac{3}{7} - 3\frac{5}{7} - 2\frac{6}{7}$ .

736. Namunaga ko'ra ayirmani toping va hisoblash usulini tushuntiring:

a)  $3\frac{5}{9} - \frac{7}{9}$ ;      b)  $4\frac{8}{15} - \frac{14}{15}$ ;      d)  $9\frac{1}{19} - 2\frac{18}{19}$ ;      e)  $5\frac{19}{53} - 3\frac{36}{53}$ .

*Namuna:* a)  $\frac{7}{9} = 1 - \frac{2}{9}$  ekanligidan foydalanamiz. Oldin ayriluvchini unga eng yaqin turgan butun son (1) bilan almashtiramiz va ayirma o'zgarmasligi uchun  $\frac{2}{9}$  ni qo'shib qo'yamiz:  $3\frac{5}{9} - \frac{7}{9} = (3\frac{5}{9} - 1) + \frac{2}{9} = 2\frac{5}{9} + \frac{2}{9} = 2\frac{5+2}{9} = 2\frac{7}{9}$ .

737. To'g'ri to'rtburchakning eni  $4\frac{5}{11}$  dm, bo'yi esa  $6\frac{7}{11}$  dm. To'g'ri to'rtburchakning perimetrini toping.

Uyda bajariladigan mashqlar



738. Yig'indini toping.

a)  $3\frac{1}{11} + 2\frac{3}{11}$ ;      b)  $6\frac{5}{7} + 9\frac{1}{7}$ ;      d)  $3\frac{7}{13} + 2\frac{5}{13}$ .

739. Yig'indini toping.

a)  $5\frac{1}{3} + \frac{2}{3}$ ;      b)  $\frac{5}{7} + 1\frac{2}{7}$ ;      d)  $5\frac{1}{5} + 2\frac{4}{5}$ ;      e)  $1\frac{3}{4} + 5\frac{1}{4}$ .

740. Yig'indini toping.

a)  $\frac{4}{9} + \frac{2}{9} + 1$ ;      b)  $\frac{4}{11} + 3 + \frac{3}{11}$ ;      d)  $1\frac{5}{12} + \frac{1}{12} + \frac{1}{12}$ ;      e)  $12 + \frac{5}{6} + \frac{1}{6}$ .

741. Yig'indini toping.

a)  $3\frac{8}{17} + 2\frac{13}{17}$ ;      b)  $6\frac{9}{14} + 2\frac{13}{14}$ ;      d)  $1\frac{5}{7} + 1\frac{6}{7}$ ;      e)  $5\frac{7}{8} + 3\frac{3}{8}$ .

*Namuna:* Yuqorida yechilgan 2- misol.



742. Ayirmani toping:

a)  $1 - \frac{1}{5}$ ;      b)  $2 - \frac{1}{8}$ ;      d)  $3 - \frac{5}{6}$ ;      e)  $7 - \frac{3}{7}$ .

743. Ayirmani toping:

a)  $5\frac{1}{4} - 3$ ;      b)  $11\frac{3}{8} - 5$ ;      d)  $3\frac{5}{8} - 2$ .

744. Ayirmani toping:

a)  $5 - 1\frac{2}{3}$ ;      b)  $11 - 7\frac{11}{15}$ ;      d)  $12 - 8\frac{5}{8}$ ;      e)  $3 - 1\frac{13}{14}$ .

745. Daryo oqimining tezligi  $2\frac{5}{7}$  km/soat, qayiqning turg'un suvdagi tezligi  $15\frac{3}{7}$  km/soat. Qayiqning oqim bo'ylab tezligini toping.



746. Ayirmani toping:

a)  $6\frac{2}{7} - \frac{1}{7}$ ;      b)  $5\frac{5}{11} - \frac{2}{11}$ ;      d)  $3\frac{7}{12} - \frac{7}{12}$ .

747. Ayirmani toping:

a)  $3\frac{3}{5} - 2\frac{1}{5}$ ;      b)  $13\frac{8}{15} - 1\frac{7}{15}$ ;      d)  $4\frac{4}{7} - 1\frac{2}{7}$ .

748. Ayirmani toping:

a)  $5\frac{6}{13} - \frac{9}{13}$ ;      b)  $9\frac{3}{14} - \frac{5}{14}$ ;      d)  $12\frac{13}{23} - 5\frac{21}{23}$ ;      e)  $3\frac{67}{83} - 1\frac{75}{83}$ .

749. Do'kondagi 15 tonna kartoshkaning  $3\frac{5}{8}$  tonnasi sotildi. Do'konda qancha kartoshka qoldi?

750. To'g'ri to'rtburchakning bo'yi  $5\frac{5}{13}$  dm, eni esa undan  $2\frac{7}{13}$  dm qisqa. To'g'ri to'rtburchakning enini toping.



751. Amallarni bajaring:

a)  $4\frac{5}{7} + 3\frac{6}{7}$ ;    b)  $7\frac{1}{13} - 5\frac{5}{13}$ ;    d)  $18\frac{12}{17} + 5\frac{15}{17}$ ;    e)  $24\frac{5}{9} - 21\frac{7}{9}$ .

752. Ifodaning qiymatini toping:

a)  $1\frac{5}{7} + 2\frac{3}{7} + 1\frac{4}{7}$ ;    b)  $13\frac{4}{7} + 5\frac{5}{7} - 2\frac{6}{7}$ ;    d)  $5\frac{1}{5} - 3\frac{3}{5} + 4\frac{4}{5}$ ;  
 e)  $7\frac{11}{16} + 2\frac{5}{16} - 8\frac{7}{16}$ ;    f)  $24\frac{1}{15} - 12\frac{4}{15} - 2\frac{3}{15}$ ;    g)  $8\frac{2}{5} - 1\frac{4}{5} - 2\frac{3}{5}$ .

753. Uchburchakning tomonlari  $15\frac{8}{10}$  dm,  $2\frac{9}{10}$  dm va  $11\frac{1}{10}$  dm. Uning perimetrini toping.



### Qiziqarli matematikaga oid masalalar

Shakllar ma'lum qonuniyat asosida qatorga joylashtirilgan. Qatorning navbatdagi shaklini chizing.

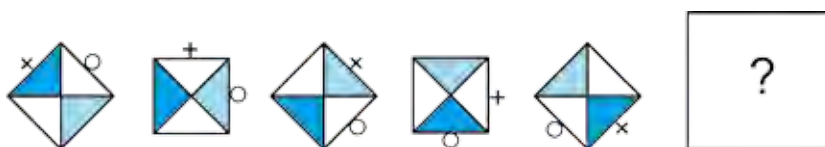

34- §

V BOBNI TAKRORLASHGA DOIR MASALALAR

754. 1 t bug'doydan 780 kg un, 25 kg yorma, 195 kg kepak olinadi. 50 t bug'doydan qancha un, yorma va kepak olinadi?
755. a) Toshkent teleminorasining balandligi 375 m. Teleminora poydevori balandligi uning 33 dan 1 qismini tashkil qiladi. Poydevor balandligini toping.  
b) Toshkent teleminorasini uzunligi 93 m bo'lgan oyoqlar ushlab turadi. Oyoqlar minora balandligining qanday qismini tashkil qiladi?
756. Quyidagi rasmlarda doiraning oltidan bir ulushlari berilgan. Ularni kasr ko'rinishida ifodalang. Bu kasrlarning qaysilari 1 ga teng? 1 dan katta? 1 dan kichik?

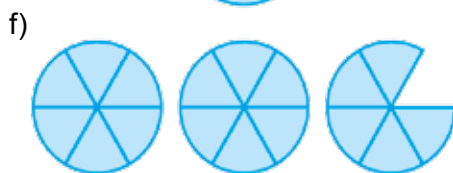
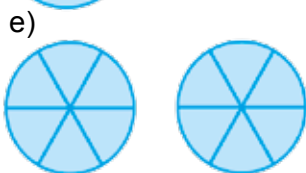
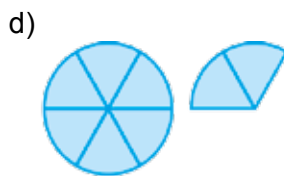
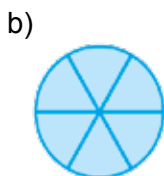
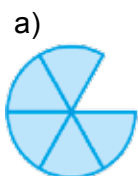

757. Rasimga qarab  $AB$ ,  $CD$  va  $EF$  kesmalarning har biri boshqalarining qanday qismini tashkil qilishini toping:

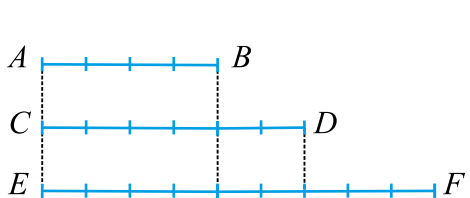

- a)  $AB = \square CD$ ; e)  $AB = \square EF$ ;  
b)  $CD = \square AB$ ; f)  $CD = \square EF$ ;  
d)  $EF = \square AB$ ; g)  $EF = \square CD$ ;

758. Agar ikkita katak 1 ni ifodalayotgan bo'lsa, quyidagi shakllar qanday sonni ifodalayapti?

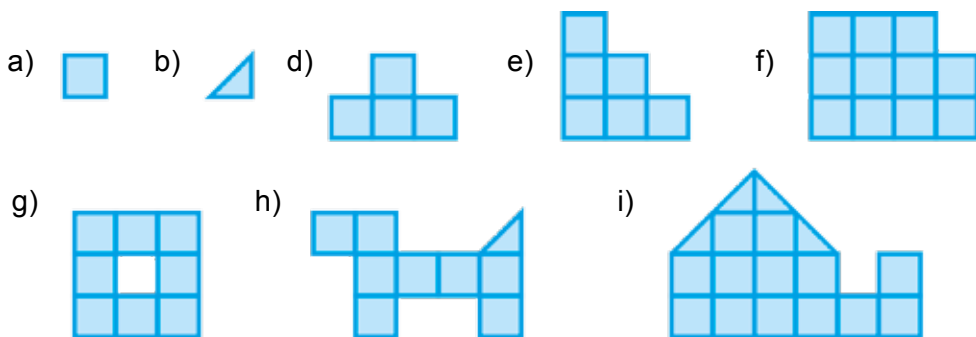

759. Dilnoza 168 betlik matnning yettidan to'rt qismini kompyuterda terdi. U matnning necha betini kompyuterda tergan? Yana necha betlik matn qolgan?

760. Yulduzchalar o'rniga tegishli katta (>) yoki kichik (<) belgisini qo'ying:

a)  $\frac{8}{13} * \frac{7}{13}$ ; || b)  $\frac{17}{21} * \frac{3}{21}$ ; || d)  $\frac{12}{19} * \frac{17}{19}$ ; || e)  $\frac{83}{121} * \frac{116}{121}$ .

761.  $c$  ning qanday qiymatlarida  $\frac{c}{17}$  kasr  $\frac{7}{17}$  kasrdan katta, lekin  $\frac{16}{17}$  kasrdan kichik bo'ladi? Bunday kasrlarning barchasini yozing.

762. Rasmga qarab: a)  $AB$  kesma  $CD$  kesmaning; b)  $CD$  kesma  $AB$  kesmaning qanday qismini tashkil qilishini toping.



763. Yotoqxona yuzi  $18 m^2$  bo'lib, u butun xonadon yuzining  $\frac{1}{9}$  qismini tashkil qiladi. Xonadon yuzini toping.

764. Suvoqchilar 6 soatda butun ishning  $\frac{3}{8}$  qismini bajarishdi. Butun ish qancha vaqtda bajariladi?

765. a)  $\frac{5}{9}$  qismi 125 ga teng; b)  $\frac{7}{12}$  qismi 14 ga teng bo'lgan sonni toping.

766. Sayyoh 5 kun yo'l bosdi. Bu butun yo'lning  $\frac{1}{5}$  qismini tashkil qiladi. Sayyoh manzilga yetib borishi uchun shu tezlikda yana necha kun yurishi kerak?

767. Ekilgan 2500 ta bodring ko'chatining 2300 tasi unib chiqdi. Ko'chatning qanday qismi unib chiqmagan?

768. Qaymoqning  $\frac{3}{20}$  qismini yog' tashkil qiladi. 120 kg qaymoqda qancha yog' bor?

769. Mobil aloqa tarmog'iga birinchi yilda shahar aholisining  $\frac{2}{7}$  qismi, ikkinchi yili esa  $\frac{3}{7}$  qismi ulandi. Shahar aholisining qanday qismi mobil aloqa tarmog'iga ulangan? Agar shaharda 87 500 kishi istiqomat qilsa, hozirda ularning qanchasi mobil aloqa xizmatidan foydalanmayapti?

770. Kasrlar ustida amallarni bajaring:

a)  $\frac{5}{12} + \frac{11}{12}$ ; || b)  $\frac{55}{86} - \frac{48}{86}$ ; || d)  $\frac{254}{391} + \frac{288}{391}$ ;  
 e)  $\frac{113}{247} - \frac{79}{247}$ ; || f)  $\frac{534}{1613} - \frac{327}{1613}$ ; || g)  $\frac{156}{2306} + \frac{1212}{2306}$ .



771. Tenglamani yeching:

a)  $x - \frac{5}{17} = \frac{10}{17}$ ; b)  $\frac{66}{71} - y = \frac{34}{71}$ ; || d)  $z + \frac{17}{27} = \frac{25}{27}$ ; e)  $\frac{234}{583} + p = \frac{489}{583}$ .

772. Tenglamani yeching:

a)  $\frac{25}{51} - x = \frac{2}{51} + \frac{3}{51}$ ; || b)  $y - \frac{27}{132} = \frac{129}{132} - \frac{35}{132}$ ;  
d)  $z + \frac{12}{45} = \frac{14}{45} + \frac{19}{45}$ ; || e)  $p + \frac{171}{492} = \frac{411}{492} - \frac{116}{492}$ .

773. Sonni noto'g'ri kasr ko'rinishida ifodalang:

a)  $5\frac{5}{13}$ ; || b)  $7\frac{7}{39}$ ; || d)  $2\frac{56}{125}$ ; || e)  $14\frac{121}{210}$ .

774. Soatda ifodalang:

a) 2 soat 30 minut; || b) 8 soat 53 minut; || d) 7 soat 32 minut.

775. Kilometrda ifodalang:

a) 16 km 350 m; || b) 2 km 889 m; || d) 29 km 561 m.

776. Yig'indini toping.

a)  $7\frac{5}{17} + 2\frac{11}{17}$ ; || b)  $6\frac{19}{34} + 4\frac{13}{34}$ ; || d)  $3\frac{5}{26} + 6\frac{6}{26}$ ; || e)  $5\frac{17}{18} + 3\frac{13}{18}$ .

777. Daryo oqimining tezligi  $2\frac{7}{9}$  km/soat, qayiqning turg'un suvdagi tezligi esa  $17\frac{4}{9}$  km/soat. Qayiqning oqim bo'ylab va oqimga qarshi tezligini toping.

778. Amallarni bajaring:

a)  $1\frac{15}{17} + 2\frac{6}{17}$ ; || b)  $6\frac{1}{19} - 3\frac{5}{19}$ ; || d)  $8\frac{1}{27} + 15\frac{25}{27}$ ; || e)  $4\frac{5}{18} - 1\frac{7}{18}$ .

779. To'g'ri to'rtburchakning bo'yi  $12\frac{5}{9}$  sm, eni esa undan  $6\frac{2}{9}$  sm qisqa. To'g'ri to'rtburchakning enini toping.

780. To'g'ri to'rtburchakning eni  $5\frac{6}{13}$  dm, bo'yi esa  $9\frac{7}{13}$  dm. To'g'ri to'rtburchakning perimetrini toping.

### Bilimingizni sinab ko'ring!



Bu bob materiallarini o'rganib chiqib, quyidagi masalalarni yecha olishingiz shart! Nazorat ishi oldidan o'zingizni sinab ko'ring!

**Test.** To'g'ri javobni aniqlang.

- Surati maxrajidan katta kasr qanday nomlanadi?  
A. To'g'ri kasr; || B. Aralash son; || D. Oddiy kasr; || E. Noto'g'ri kasr.
- Noto'g'ri kasr qiymati haqida nima deyish mumkin?  
A. 1 dan katta; || B. 1 dan kichik; || D. 1 ga teng; || E. 0 ga teng.
- Bir xil maxrajli ikki kasrdan qaysisining surati kichik bo'lsa, o'sha kasr ... bo'ladi.  
A. Kichik; || B. Katta; || D. To'g'ri kasr; || E. Noto'g'ri kasr.

## 8- nazorat ishi namunasi

1. Amallarni bajaring:

a)  $\frac{10}{11} - \frac{4}{11} + \frac{3}{11}$ ; || b)  $4\frac{5}{9} + 3\frac{8}{9}$ ; || d)  $6 - 2\frac{3}{8}$ ; || e)  $5\frac{6}{13} - 1\frac{11}{13}$ .

2. Sayohatchi 3 soatda 14 km yurdi. Uning tezligini toping.

3. Garajda 45 ta avtomobil bor. Ularning  $\frac{5}{9}$  qismi yengil avtomobil. Garajda nechta yengil avtomobil bor?

4. Tenglamani yeching: a)  $5\frac{6}{7} - x = 3\frac{2}{7}$ ; || b)  $y + 4\frac{8}{11} = 10\frac{7}{11}$ .

5. Qanday sonni 8 ga bo'lsa, bo'linma  $5\frac{7}{8}$  ga teng bo'ladi?



### Qiziqarli matematikaga oid masalalar

*Sonli labirint.* Tashqi aylanada turgan sonlarga ichki aylanada turgan qaysi sonni qo'shsa, markazdagi son hosil bo'ladi?

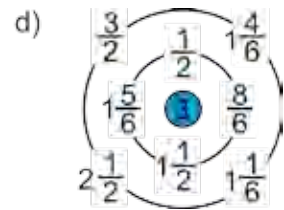
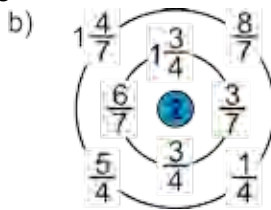
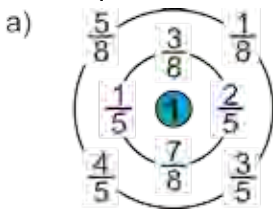

### Matematika tarixiga oid lavhalar

#### Qadimgi Axmes masalasi

Misrdan topilgan papirus qog'ozida bundan ming yillar oldin yashagan Axmesning matematikaga, xususan, kasrlarga oid ko'pgina masalalari keltirilgan.

Mana ulardan biri: 7 ta nonni 8 kishiga teng taqsimlab bering.

Juda oson masala ekan-ku, deyishingiz mumkin. Haqiqatan, har bitta nonni 8 ta bo'lakka bo'lib, har bir kishiga 7 tadan ulush berib, masalani yechish mumkin.

Lekin, hamma gap shundaki, qadimgi misrliklar nonni imkoni boricha kam bo'laklarga bo'lib, bu masalani yechishgan. Siz ham bu yechimni topishga urinib ko'ring-chi!

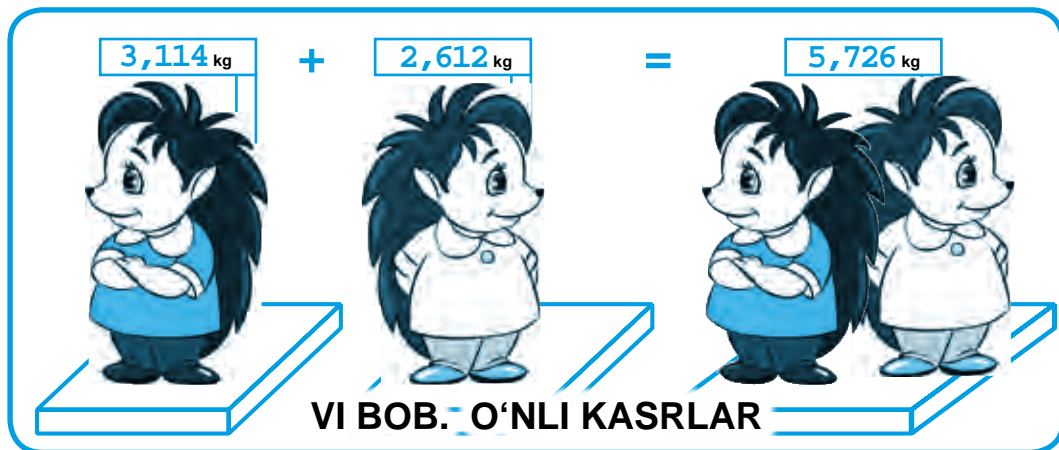

**35- §.**

**O'NLI KASRLARNING YOZILISHI VA O'QILISHI**

Shunday kasr sonlar borki, ular ustida amallarni xuddi natural sonlardagidek oson bajarish mumkin. Bu kasrlar maxraji 10, 100, 1000 va hokazo sonlardan iborat bo'lgan sonlardir. Bunday kasrlar *o'nli kasrlar* deb ataladi. Mazkur bobda o'nli kasrlarning yo'zilishi va ular ustida amallar qanday bajarilishi xususida to'xtalamiz.

*1- misol.* 8 m 52 sm ni metrda ifodalaylik.

$$1 \text{ sm} = \frac{1}{100} \text{ m bo'lgani uchun, } 52 \text{ sm} = \frac{52}{100} \text{ m bo'ladi.}$$

$$\text{U holda, } 8 \text{ m } 52 \text{ sm} = 8 \text{ m} + 52 \text{ sm} = 8 \text{ m} + \frac{52}{100} \text{ m} = 8\frac{52}{100} \text{ m.}$$

$$\text{Ikkinchi tomondan, } 8 \text{ m } 52 \text{ sm} = 8 \text{ m} + 50 \text{ sm} + 2 \text{ sm} =$$

$$= 8 \text{ m} + 5 \text{ dm} + 2 \text{ sm} = 8 \text{ m} + \frac{5}{10} \text{ m} + \frac{2}{100} \text{ m.}$$

$8\frac{52}{100}$  kasr vergul yordamida maxrajsiz **8,52** ko'rinishda yoziladi va *8 butun yuzdan 52* deb o'qiladi. Demak,

$$8\frac{52}{100} \text{ m} = 8,52 \text{ m}$$

Bu yozuvda vergulning chap tomonida 8 soni turibdi. U butun metrlar sonini ko'rsatadi. Vergulning o'ng tomonidan birinchi o'rinda turgan 5 raqami – metrning o'ndan bir ulushlari, ya'ni detsimetrlar sonini, ikkinchi o'rinda turgan 2 raqami esa metrning yuzdan bir ulushlari, ya'ni santimetrlar sonini ko'rsatadi. Ko'rib turganingizdek, bu yozuv natural sonlarning o'nli yozuviga juda o'xshab ketadi: har bir xona birligi chapdan o'ngga qarab o'zidan oldin kelgan xona birligidan 10 marta kichik.

8,52 yozuv  $8\frac{52}{100}$  *kasr sonining o'nli ko'rinishdagi ifodasi* yoki *o'nli kasr* deb ataladi.

2- misol. 4 kg 565 g ni kilogrammda ifodalaylik:

$$4 \text{ kg } 565 \text{ g} = 4 \text{ kg} + 565 \text{ g} = 4 \text{ kg} + \frac{565}{1000} \text{ kg} = 4 \frac{565}{1000} \text{ kg}$$

ekanligini topamiz.

$8\frac{3}{10}$  sonining kasr qismi maxraji 10 ga,  $8\frac{52}{100}$  sonining kasr qismi maxraji

100 ga,  $4\frac{565}{1000}$  sonining kasr qismi maxraji esa 1000 ga teng.

**!** Maxraji 10, 100, 1000 va hokazo bo'lgan sonlarni (maxrajsiz) o'nli kasr ko'rinishida quyidagicha yozishga kelishib olingan:

- oldin sonning butun qismi yoziladi;
- so'ng kasr qismining surati yoziladi va ular bir-biridan vergul bilan ajratiladi.

Masalan,  $8\frac{3}{10}$  soni 8,3 tarzida yoziladi va «8 butun o'ndan 3» deb,  $4\frac{565}{1000}$  soni esa 4,565 tarzida yoziladi va «4 butun mingdan 565» deb o'qiladi.

Shunday qilib,  $8 \text{ dm } 3 \text{ sm} = 8\frac{3}{10} \text{ dm} = 8,3 \text{ dm}$ ;

$$4 \text{ kg } 565 \text{ g} = 4\frac{565}{1000} \text{ kg} = 4,565 \text{ kg}.$$

**!** Kasr qismining maxraji 10, 100, 1000 va hokazo bo'lgan har qanday sonni o'nli kasr ko'rinishida ifodalash mumkin.

Agar kasr to'g'ri kasr bo'lsa, uning o'nli yozuvida butun qism 0 deb olinadi..

Masalan,  $\frac{35}{100}$  soni – to'g'ri kasr. Bu kasr 0,35 tarzida yoziladi va «0 butun yuzdan 35» deb o'qiladi. Demak,  $\frac{35}{100} = 0,35$ .

**!** O'nli ko'rinishda yozilayotgan sonning kasr qismi maxrajida nechta nol bo'lsa, suratida ham, verguldan keyin ham shuncha raqam bo'lishi kerak.

Masalan,  $5\frac{67}{1000}$  sonining kasr qismi suratida ikkita raqam, maxrajida esa uchta nol bor. Shuning uchun oldin surat oldiga bitta nol qo'yib, uni  $5\frac{067}{1000}$  tarzida yozib olamiz. So'ng uni 5,067 o'nli kasr ko'rinishida ifodalaymiz va «5 butun mingdan 67» deb o'qiymiz. Shunga o'xshash,  $3\frac{7}{1000} = 3\frac{007}{1000} = 3,007$ .

### **?** Savollarga javob bering!

1. Qanday sonlarni o'nli kasr ko'rinishida yozish mumkin?
2. Sonlarni o'nli ko'rinishda yozishning qanday afzalliklari bor?
3. O'nli kasrning butun va kasr qismi nima bilan ajratiladi?

**Sinfda bajariladigan mashqlar**



**781.** Sonning butun va kasr qismini ayting:

- a)  $4\frac{7}{10}$ ; || b)  $27\frac{28}{1000}$ ; || d)  $\frac{78}{100}$ ; || e)  $5\frac{3}{10}$ ; || f)  $35\frac{92}{1000}$ ; || g)  $4\frac{332}{10\ 000}$ .

**782.** O'nli kasrlarni o'qing:

- a) 3,6;      12,5;      392,3;      77,7;      1,8;      0,9;  
 b) 6,43;      38,17;      983,50;      3,910;      0,47;      0,13;  
 d) 6,181;      0,018;      314,403;      5,0304;      0,2006;      0,01001.

**783.** (Matematik diktant) O'nli kasr ko'rinishida yozing:

o'n uch butun o'ndan bir; nol butun yuzdan qirq to'rt; besh butun yuzdan bir; yigirma bir butun mingdan o'n sakkiz; uch butun mingdan bir yuz oltmish bir; nol butun mingdan sakson bir; nol butun o'n mingdan ikki yuz ellik ikki.

**784.** Sonni o'nli kasr ko'rinishida yozing va o'qing.

- a)  $4\frac{7}{10}$ ; || b)  $7\frac{318}{1000}$ ; || d)  $\frac{67}{100}$ ; || e)  $\frac{3}{10}$ ; || f)  $3\frac{9}{100}$ ; || g)  $14\frac{433}{10\ 000}$ .

*Namuna:*  $3\frac{23}{100} = 3,23$ ;       $7\frac{46}{1000} = 7\frac{046}{1000} = 7,046$ .

**785.** Sonning butun va kasr qismlarini ajrating va o'nli kasr ko'rinishida yozing:

- a)  $\frac{76}{10}$ ; || b)  $\frac{7318}{1000}$ ; || d)  $\frac{6721}{100}$ ; || e)  $\frac{343}{10}$ ; || f)  $\frac{9907}{100}$ ; || g)  $\frac{33\ 000}{10\ 000}$ .

**786.** Oddiy kasr yoki aralash son ko'rinishida ifodalang:

- a) 3,14; || b) 10,8; || d) 443,91; || e) 7,008; || f) 0,91; || g) 0,03.

*Namuna:*  $25,09 = 25 + \frac{9}{100} = 25\frac{9}{100}$ .

**787.** Bo'linmani o'nli kasr ko'rinishida yozing:

- a)  $435 : 10$ ; || b)  $9803 : 100$ ; || d)  $149 : 10000$ ; || e)  $27 : 1000$ .

*Namuna:*  $573 : 100 = \frac{573}{100} = 5\frac{73}{100} = 5,73$ .



**788.** Quyidagi sxema asosida savollarga javob bering:



- a) 1 millimetr detsimetrning; b) 1 millimetr metrning; d) 1 santimetr kilometrning;  
 e) 1 metr kilometrning qanday qismini tashkil qiladi?

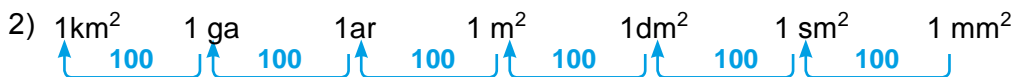

- a)  $1\text{mm}^2$  santimetr kvadratning; b)  $1\text{sm}^2$  metr kvadratning;  
 d)  $1\text{dm}^2$  kilometr kvadratning; e)  $1\text{dm}^2$  arning;  
 f) 1 ar kilometr kvadratning qanday qismini tashkil qiladi?



- a) 1 g sentnening;      b) 1 kg tonnaning qanday qismini tashkil qiladi?

**789.** Metr va santimetrlarda ifodalang: a) 6,13 m; b) 16,01 m; d) 7,10 m.

*Namuna:*  $56,65 \text{ m} = 56 \text{ m} + \frac{65}{100} \text{ m} = 56 \text{ m } 65 \text{ sm.}$

**790.** 1) Kilogrammda ifodalang va o'nli kasr ko'rinishida yozing:

- a) 5 kg 813 g;    b) 457 g;    d) 2307 g;    e) 7 kg 97 g;    f) 1 kg 2 g;    g) 14 835 g.

*Namuna:*  $73 \text{ kg } 278 \text{ g} = 73 \text{ kg} + \frac{278}{1000} \text{ kg} = 73 \frac{278}{1000} \text{ kg} = 73,278 \text{ kg.}$

- 2) Tonna va kilogrammlarda ifodalang: a) 2,783 t;    b) 45,01 t;    d) 25,019 t.

*Namuna:*  $6,54 \text{ t} = 6,540 \text{ t} = 6 \text{ t} + \frac{540}{1000} \text{ t} = 6 \text{ t } 540 \text{ kg.}$

- 3) So'mda ifodalang va o'nli kasr ko'rinishida yozing:

- a) 14 so'm 58 tiyin;    b) 5 so'm 7 tiyin;    d) 403 tiyin;    e) 1438 tiyin.

*Namuna:*  $34 \text{ so'm } 45 \text{ tiyin} = 34 \text{ so'm} + \frac{45}{100} \text{ so'm} = 34,45 \text{ so'm.}$



### Uyda bajariladigan mashqlar

**791.** O'nli kasr ko'rinishida yozing:

- a)  $3 \frac{9}{10}$ ;    ||    b)  $\frac{674}{1000}$ ;    ||    d)  $\frac{35}{100}$ ;    ||    e)  $8 \frac{7}{100}$ ;    ||    f)  $7 \frac{48}{10\ 000}$ ;    ||    g)  $2 \frac{889}{10\ 000}$ .

**792.** O'nli kasr ko'rinishida yozing:

o'n butun o'ndan ikki; nol butun mingdan bir yuz ellik to'rt; olti butun yuzdan uch; olti butun mingdan ikki yuz bir; nol butun mingdan o'n ikki; o'n butun mingdan yetti yuz to'qson.

**793.** Bo'linmani o'nli kasr ko'rinishida yozing:

- a) 385:10; || b) 8503:100; || d) 491:10 000; || e) 75:1000; || f) 783:1000; || g) 9:10000.



**794.** Metrda ifodalang va o'nli kasr ko'rinishida yozing: a) 34 dm; b) 78 sm; d) 301 sm; e) 17 mm; f) 43 m 1 sm; g) 9 sm 2 mm; i) 4 dm 9 mm.

**795.** Kvadrat metrda ifodalang:

- a)  $7 \text{ m}^2 \text{ } 61 \text{ dm}^2$ ;    ||    b)  $633 \text{ dm}^2$ ;    ||    d)  $25 \text{ m}^2 \text{ } 80 \text{ dm}^2$ ;    ||    e)  $32 \text{ m}^2 \text{ } 1 \text{ dm}^2$ .

796. Oralaridagi masofa 19 km 500 m bo'lgan ikki punktdan bir vaqtda bir xil yo'nalishda 12 km/soat tezlik bilan velosipedchi va 90 km/soat tezlik bilan yengil avtomobil yo'lga chiqdi. Yengil avtomobil velosipedchini qancha vaqtdan keyin quvib yetadi?

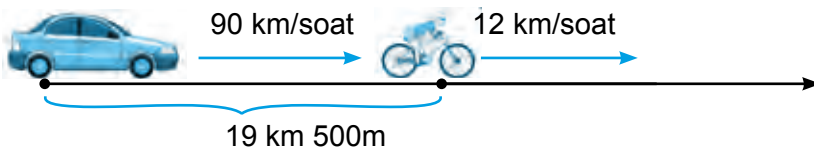

797. Uch kunda do'konda jami 1 971 500 so'mlik savdo qilindi. Agar birinchi kuni ikkinchi kunga qaraganda 23 500 so'm ko'p, uchinchi kuni esa birinchi kunga qaraganda 56 000 so'm kam savdo qilingan bo'lsa, bu do'konda har qaysi kunda qanchadan savdo qilingan?

### Matematika tarixiga oid lavhalar



O'nli kasrlar ustida amallar bajarish qoidalarini XV asr boshida Samarqanddagi Ulug'bek maktabining mashhur namoyandasi, Sharqning buyuk matematik olimi Jamshid G'iyosiddin al-Koshiy (1385–1430) o'zining, «Muftoh al-hisob» («Hisob ilmi kaliti») deb nomlangan asarida bayon qilgan. Al-Koshiy o'nli kasrni hozirda qabul qilingan ko'rinishda belgilagan. Faqat u verguldan foydalanmagan. Sonning kasr qismini qizil rangda yozgan yoki tik tayoqcha bilan butun qismidan ajratgan.

Bu haqda yevropaliklar bexabar bo'lishgan. Yevropaga o'nli kasrlar 150 yildan keyin kirib kelgan. Niderlandiyalik muhandis va olim Simon Stiven o'nli kasrlar yozuvini qaytadan kashf etgan. Lekin Stiven o'nli kasrlarni murakkab tarzda belgilagan. XVII asrga kelib o'nli kasrlar hozirgi ko'rinishda ishlatila boshlagan.

### Qiziqarli matematikaga oid masalalar



**Foydali ermak.** Avtobusda ketayotib uzoq yo'lni qanday yaqin qilish mumkin? Bu – juda oson. Biror foydali ish bilan mashg'ul bo'lsangiz, manzilga yetib kelganingizni ham bilmay qolasiz. Mana o'sha ermaklardan biri:

Avtobus chiptasida yozilgan raqamlarning o'rnini o'zgartirmay, qavslar va to'rt arifmetik amallardan foydalanib 100 (yoki unga eng yaqin) sonini hosil qiling.

Masalan, chiptada oltita raqamdan iborat 136091 soni yozilgan bo'lsin. Undan raqamlar o'rnini o'zgartirmagan holda, qavslar va to'rtta arifmetik amallardan foydalanib quyidagicha 100 sonini hosil qilish mumkin:

$$1 \cdot 3 + 6 + 0 + 91 = 100, \quad (1 + 3 + 6 + 0) \cdot (9 + 1).$$

100 ni yana boshqa qanday usullar bilan hosil qilish mumkin?

**36- §.**

**O'NLI KASRLARNI TAQQOSLASH**

Uzunligi 8 sm, ya'ni 80 mm bo'lgan  $AB$  kesma berilgan bo'lsin. Bu kesma uzunligining har bir o'lchovini detsimetrlarda ifodalaylik.

$$1 \text{ sm} = \frac{1}{10} \text{ dm} \text{ va } 8 \text{ sm} = \frac{8}{10} \text{ dm} \text{ bo'lgani uchun } AB = 0,8 \text{ dm} \text{ bo'ladi.}$$

$$1 \text{ mm} = \frac{1}{100} \text{ dm} \text{ va } 80 \text{ mm} = \frac{80}{100} \text{ dm} \text{ bo'lgani uchun } AB = 0,80 \text{ dm} \text{ bo'ladi.}$$

Demak,  $AB = 0,8 \text{ dm} = 0,80 \text{ dm}.$

Xulosa:  $0,8$  va  $0,80$  kasrlar bir-biriga teng:  $0,8 = 0,80$



Agar o'nli kasrning o'ng tomonida turgan nol olib tashlansa yoki kasrning o'ng tomoniga nollar yozilsa, berilgan kasrga teng kasr hosil bo'ladi.

Masalan,

$$\begin{aligned} 0,43 &= 0,430 = 0,4300; & \parallel & 6,7 &= 6,70 = 6,700; & \parallel & 18 &= 18,0 = 18,000; \\ 0,900 &= 0,90 = 0,9; & \parallel & 43,200 &= 43,20 = 43,2; & \parallel & 31,00 &= 31,0 = 31. \end{aligned}$$

*1- misol.* 4,54 va 6,9 o'nli kasrlarni o'zaro taqqoslaylik.

Oldin ularning verguldan keyingi o'nli raqamlari sonini tenglashtiramiz. Buning uchun 6,9 kasr o'ng tomoniga bitta nol yozamiz: 4,54 va 6,90 kasrlarni hosil qilamiz. Ularni noto'g'ri kasr ko'rinishida ifodalaymiz:

$$4,54 = 4\frac{54}{100} = \frac{454}{100}, \quad \parallel \quad 6,90 = 6\frac{90}{100} = \frac{690}{100}.$$

Bu kasrlarning maxrajlari bir xil.

Demak, ulardan qaysi birining surati katta bo'lsa, shu kasr katta bo'ladi:

$$454 < 690 \quad \text{bo'lgani uchun} \quad \frac{454}{100} < \frac{690}{100}.$$

Demak,  $4,54 < 6,90$ , ya'ni  $4,54 < 6,9$ .



Ikkita o'nli kasrni o'zaro taqqoslash uchun:

- oldin ulardan birining o'ng tomoniga nollar yozib, ularning verguldan keyingi raqamlari soni tenglashtiriladi;
- so'ng vergullar tashlab yuboriladi va hosil bo'lgan natural sonlar o'zaro taqqoslanadi.

*2- misol.* 23,54 va 16,9 sonlarini taqqoslaylik.

1. Sonlarning verguldan keyingi raqamlari sonini tenglashtiramiz: 23,54 va 16,90;

2. Vergullarni tashlab yuboramiz va sonlarni taqqoslaymiz:  $2354 > 1690$ ;  
Demak,  $23,54 > 16,9$ .

**36.2. O'nli kasrlarni sonlar nurida tasvirlash**

O'nli kasrlarni xuddi oddiy kasrlar kabi sonlar nurida tasvirlash mumkin.



**3- misol.** 0,3 oʻnli kasrni sonlar nurida tasvirlaylik.

Buning uchun:

- oldin uni oddiy kasr koʻrinishida ifodalaymiz:  $0,3 = \frac{3}{10}$ ;
- soʻng birlik kesmani 10 ta teng boʻlakka boʻlib, chap tomondan bu boʻlaklardan uchtasini sanaymiz va  $A(0,3)$  nuqtani belgilaymiz. Bu nuqta — 0,3 oʻnli kasrning sonlar nuridagi tasviri boʻladi (1- rasm).

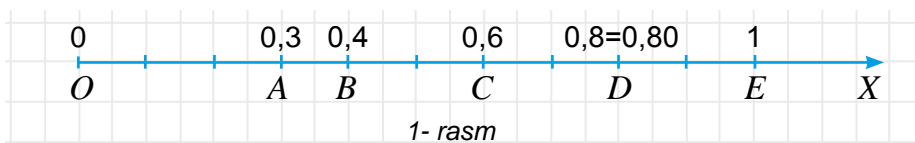

Sonlar nurida teng oʻnli kasrlar bitta nuqta bilan tasvirlanadi.



Masalan, 0,8 va 0,80 teng kasrlar birgina  $D$  nuqta bilan tasvirlanadi (1- rasm).

Sonlar nurida katta oʻnli kasr kichigidan oʻngda, kichik oʻnli kasr esa kattasidan chapda yotadi.



Masalan,  $0,3 < 0,4 < 0,6$ . Shuning uchun sonlar nurida  $B(0,4)$  nuqta  $A(0,3)$  nuqtadan oʻngda,  $C(0,6)$  nuqtadan esa chapda yotadi (1- rasm).

**Savollarga javob bering!**



1. Agar oʻnli kasrning oʻng tomoniga nollar yozilsa, qanday kasr hosil boʻladi?
2. Agar oʻnli kasrning oʻng tomonida turgan nol olib tashlansa, kasr oʻzgaradimi?
3. Oʻnli kasrlarni taqqoslash qoidasini tushuntirib bering.
4. Sonlar nurida oʻnli kasrlar qanday tasvirlanadi?
5. Sonlar nurida tasvirlangan kasrlarning bir-biridan katta yoki kichikligini qanday aniqlash mumkin?

**Sinfda bajariladigan mashqlar**



**798.** Shunday oʻnli kasr yozingki, u:

- a) 0,95 ga teng va verguldan keyin 4 ta raqami bor boʻlsin;
- b) 195 ga teng va verguldan keyin 3 ta raqami bor boʻlsin;
- d) 6,300000 ga teng va verguldan keyin 3 ta raqami bor boʻlsin.

**799.** Har bir qatordagi oʻzaro teng sonlarni toping:

- a) 0,8; 0,08; 0,80; 0,008; 0,8000; 0,0008;
- b) 5,1; 5,01; 5,010; 5,001; 5,01000; 5,00010.

**800.** Sonlarni taqqoslang:

- |                      |  |                     |  |                       |
|----------------------|--|---------------------|--|-----------------------|
| a) 85,09 va 67,99;   |  | b) 55,7 va 55,7000; |  | d) 0,908 va 0,918;    |
| e) 7,6431 va 7,6429; |  | f) 0,5 va 0,724;    |  | g) 0,0025 va 0,00247. |

**Namuna:** Yuqorida koʻrilgan 1- va 2- misol.

- 801.** a) 3,456; 3,465; 8,149; 8,079; 0,453; 0,4532 sonlarni oʻsib borish tartibida;  
 b) 0,456; 0,065; 0,009; 0,079; 0,0093; 0,0502 sonlarni kamayib borish tartibida joylashtiring.

**802.** Daftaringizga chizmani ko'chiring. Har bir chiziqchaga mos o'nli kasrni yozing.



**803.** Daftarning 10 ta katagi uzunligini birlik kesma sifatida olib, sonlar nurida  $A(0,2)$ ,  $B(0,6)$ ,  $C(0,8)$ ,  $D(1,3)$  va  $F(1,5)$  nuqtalarni belgilang.

**804.** Nuqtalardan qaysi biri sonlar nurida chapda joylashgan?



a)  $A(1,3)$  yoki  $B(1,8)$ ; b)  $C(0,33)$  yoki  $D(0,37)$ ; d)  $E(5,5)$  yoki  $F(5,45)$ .

**805.** Miqdorlarni taqqoslang:

- |                               |   |
|-------------------------------|---|
| a) 324,17 kg va 320,78 kg;    | f) 1,2 t va 1643,3 kg;                    |
| b) 98,52 m va 65,39 m;        | g) 1272 m va 13,888 km;                   |
| d) 23,5°C va 13,59°C;         | h) 7772,45 a va 7,77248 ga;               |
| e) 21,289 soat va 21,29 soat; | l) 32,143 litr va 32149 sm <sup>3</sup> . |

*Namuna:* 5,78 kg va 3,79 kg. Vergullarni tashlab yuboramiz va natural sonlarni taqqoslaymiz:  $578 > 379$ . Demak,  $5,78 \text{ kg} > 3,79 \text{ kg}$ .

**806.** O'nli kasrlarni taqqoslang va natijani tengsizlik ko'rinishida yozing:

- |                    |                    |                     |
|--------------------|--------------------|---------------------|
| a) 18,22 va 5,75;  | b) 3,50 va 3,6;    | d) 0,76 va 0,8;     |
| e) 0,1009 va 0,19; | f) 99,22 va 100,9; | g) 0,230 va 0,2310. |

**807.** Quyidagi o'nli kasrlar orasida joylashgan natural sonlarni yozing:

- |                       |                       |                      |
|-----------------------|-----------------------|----------------------|
| a) 0,9 va 3,41;       | b) 4,53 va 13,4;      | d) 56,456 va 65,609; |
| e) 209,67 va 213, 03; | f) 3007,4 va 3010,01; | g) 28,13 va 34,09.   |

**808.** O'nli kasrlarni oldin o'sib borish, so'ng kamayib borish tartibida joylashtiring:

- |           |       |        |        |        |         |        |
|-----------|-------|--------|--------|--------|---------|--------|
| a) 1,708; | 0,98; | 4,708; | 13,2;  | 7,613; | 0,99;   | 1,123; |
| b) 0,02;  | 3,02; | 0,302; | 0,022; | 0,202; | 0,0302; | 20,3.  |

**809.** Tengsizlikni tekshiring.

- a)  $2 > 1,75$ ; || b)  $18,006 < 19,0001$ ; || d)  $71,2 > 71,2005$ ; || e)  $24,009 < 23,999$ .



### Uyda bajariladigan mashqlar

**810.** 2,47; 3,8; 0,0703 va 231,808 o'nli kasrlarning o'ng tomoniga nollar yozib, ularning verguldan keyingi raqamlari sonini tenglashtiring.

**811.** Miqdorlarni taqqoslang:

- |                      |                        |                      |
|----------------------|------------------------|----------------------|
| a) 57,99 va 58,01;   | d) 1129,9 va 1130, 01; | f) 91,39 va 91,4;    |
| b) 60,529 va 60,530; | e) 34,890 va 34,891;   | g) 124,5 va 124,501. |

812. Har bir chizmada 0,5842 sonini belgilang:



813. Daftarning 10 ta katagi uzunligini birlik kesma sifatida olib, sonlar nurida  $A(0,1)$ ;  $B(0,3)$ ;  $C(1,2)$  va  $D(1,8)$  nuqtalarni belgilang.



814. Nuqtalardan qaysi biri sonlar nurida o'ngda joylashgan?

a)  $A(2,1)$  yoki  $B(2,3)$ ; || b)  $C(10,5)$  yoki  $D(10,509)$ .

815. To'g'ri tengsizlik hosil qilish uchun katakcha o'rniga qo'yish mumkin bo'lgan hamma raqamlarni toping:

a)  $0, \square 3 > 0,13$ ; || b)  $0,1 \square < 0,18$ ; || d)  $5,64 > 5, \square 8$ ; || e)  $3,51 < 3, \square 1$ .

816. Oralaridagi masofa 782 km bo'lgan ikki shahardan ikki poyezd bir-biriga qarab turli vaqtda yo'lga chiqdi. Birinchi poyezd 52 km/soat, ikkinchisi 61 km/soat tezlik bilan yurdi. Birinchi poyezd 416 km yurganidan keyin ikkinchisi bilan uchrashdi. Poyezdlardan biri ikkinchisidan necha soat oldin yo'lga chiqqan?

817. Amallarni bajaring:

a)  $79348 - 64 \cdot 84 : 28 + 653900 : 130$ ;

b)  $108150 : 525 + 24 \cdot (10000 - 24 \cdot 303) - 23598$ .

818. Vatanimiz qadimiy yodgorliklarga boy. Quyidagi rasmlarda O'zbekistonning turli viloyatlaridagi minoralar keltirilgan:

a) Xiva shahridagi Islom Xo'ja minorasi, balandligi – 44,5 m.

b) Vobkent minorasi, balandligi – 39 m;

d) Jarqo'rg'on minorasi, balandligi – 21,6 m;

e) Toshkent shahridagi Hazrati Imom masjidi minoralari, balandligi – 59 m;

f) Xiva shahridagi Kalta Minor, balandligi – 28 m;

g) Buxoro shahridagi Minorayi-Kalon, balandligi – 45,5 m,

Bu minoralarning balandliklarini kamayib borish tartibida joylashtiring.



37-§

**O'NLI KASRLARNI QO'SHISH VA AYIRISH**

1- misol. 4,5 va 1,451 o'nli kasrlarni qo'shaylik.

Oldin ularning verguldan keyingi raqamlari sonini tenglashtiramiz. Buning uchun ulardan birinchisining o'ng tomoniga ikkita nol yozamiz:  $4,5 = 4,500$ .

So'ng ularni aralash son ko'rinishida yozamiz va qo'shamiz:

$$4,500 = 4 \frac{500}{1000}, \quad 1,451 = 1 \frac{451}{1000},$$

$$4,5 + 1,451 = 4 \frac{500}{1000} + 1 \frac{451}{1000} = 5 \frac{500 + 451}{1000} = 5 \frac{951}{1000} = 5,951.$$

Demak, 4,5 va 1,451 o'nli kasrlarning yig'indisi 5,951 ga teng. Bu natijani o'nli kasrlarni «ustun» ko'rinishida qo'shib ham hosil qilish mumkin (1- rasm).

$$\begin{array}{r} 4,500 \\ + 1,451 \\ \hline 5,951 \end{array}$$

1- rasm

2- misol. Endi shu sonlarning ayirmasini ham topaylik:

$$4,5 - 1,451 = 4 \frac{500}{1000} - 1 \frac{451}{1000} = 3 \frac{500 - 451}{1000} = 3 \frac{49}{1000} = 3,049.$$

Bu holda ham natijani o'nli kasrlarni «ustun» ko'rinishida ayirib, qulayroq usulda topishimiz mumkin (2- rasm).

$$\begin{array}{r} 4,500 \\ - 1,451 \\ \hline 3,049 \end{array}$$

2- rasm



O'nli kasrlarni qo'shish (ayirish) uchun

- oldin ularning verguldan keyingi raqamlari soni nollar qo'yib tenglashtiriladi;
- so'ng ular «ustun» qilib, vergul vergulning tagiga tushadigan qilib yoziladi;
- vergulga e'tibor bermasdan qo'shish (ayirish) bajariladi;
- hosil bo'lgan songa tepadagi o'nli kasrlar vergullari tagiga tushadigan qilib vergul qo'yiladi.

Aytish joizki, o'nli kasrlarni ularning verguldan keyingi raqamlarini nollar qo'yib tenglashtirmasdan ham qo'shish va ayirish mumkin. Bu holda, nollar yozilmasa-da, ular bo'sh o'rinlarda turibdi deb ish ko'riladi.

3- misol. 0,666 o'nli kasrni quyidagi yig'indi ko'rinishida ifodalash mumkin:

$$0,666 = 0,600 + 0,060 + 0,006 = 0,6 + 0,06 + 0,006.$$

Ko'rinib turibdiki, bu kasr o'ndan 6, yuzdan 6 va mingdan 6 lar yig'indisidan iborat.

$0,666 = 0,6 + 0,06 + 0,006$  yozuv 0,666 *sonining xona birliklari bo'yicha yoyilmasi yoki xona qo'shiluvchilari bo'yicha yig'indisi* deb ataladi.

Shunday qilib, 0,666 o'nli kasrning verguldan keyingi birinchi 6 raqami – o'ndan birlar sonini, ikkinchi 6 raqami – yuzdan birlar sonini va uchinchi 6 raqami esa mingdan birlar sonini ko'rsatadi.

Kasrning o'nli yozuvida verguldan keyingi:

- birinchi xona – *o'ndan birlar xonasi*;
- ikkinchi xona – *yuzdan birlar xonasi*;
- uchinchi xona – *mingdan birlar xonasi* deb ataladi va hokazo.

**4- misol.** 346,675 kasrni xona birliklari bo'yicha yoyaylik.

Uning butun qismi yuzlar, o'nlar va birlar xonasidan, kasr qismi esa o'ndan birlar, yuzdan birlar va mingdan birlar xonasidan iborat:

$$346,675 = 300 + 40 + 6 + 0,6 + 0,07 + 0,005.$$

Bu sonning yoyilmasi 3 ta yuzlar, 4 ta o'nlar, 6 ta birlar, 6 ta o'ndan birlar, 7 ta yuzdan birlar va 5 ta mingdan birlar yig'indisidan iborat.

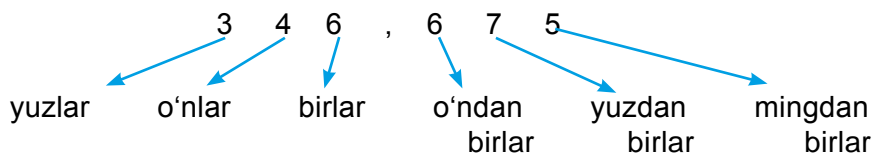

O'qli kasrning xona birliklari bo'yicha yoyilmasi uni sonlar nurida tasvirlashni osonlashtiradi.

**5- misol.** Sonlar nurida 1,36 sonini belgilaylik.

Buning uchun bu sonni xona birliklari bo'yicha yoyamiz:  $1,36 = 1 + 0,3 + 0,06$ .

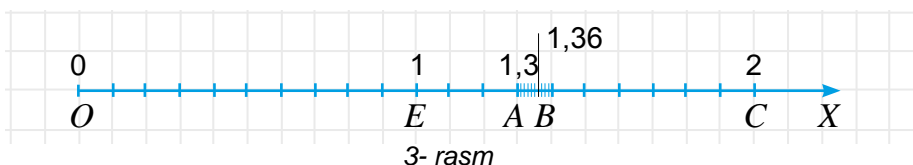

Sonlar nuri boshidan  $OE$  birlik kesmani ajratamiz va  $E(1)$  nuqtani belgilaymiz (3- rasm). Keyingi  $EC$  birlik kesmani 10 ta teng bo'lakka bo'lib, birlik kesmaning o'ndan bir ulushlarini hosil qilamiz. Ulardan 3 tasini sanab,  $A(1,3)$  sonni belgilaymiz.

So'ng 1,3 sondan keyin keluvchi, birlik kesmaning o'ndan bir ulushini yana 10 ta teng bo'lakka bo'lamiz. Natijada birlik kesmaning yuzdan bir ulushlarini hosil qilamiz. Ulardan 6 tasini sanab,  $B(1,36)$  sonni belgilaymiz.

O'qli kasrlarni xona birliklari bo'yicha ham taqqoslash mumkin.



**6- misol.** 4,32 va 6,1 o'qli kasrlarni taqqoslaylik.

4,32 sonining butun qismi 6,1 sonining butun qismidan kichik ( $4 < 6$ ).

Demak,  $4,32 < 6,1$ .

**7- misol.** 3,491 va 3,46 o'qli kasrlarni taqqoslaylik.

Bu sonlarning butun qismi – 3, o'ndan birlar xonasida turgan raqamlari esa 4 ga teng bo'lib, ular o'zaro teng. Lekin birinchi kasrning yuzdan birlar xonasida turgan 9 raqami, ikkinchi kasrning yuzdan birlar xonasida turgan 6 raqamidan katta ( $9 > 6$ ). Shuning uchun  $3,491 > 3,46$ .

### O'qli kasrlar uchun qo'shish qonunlari

Natural sonlarda bo'lgani kabi o'qli kasrlar uchun ham qo'shishning o'rin almashtirish va guruhlash qonunlari o'rinli bo'ladi.

O'qli kasrlar uchun qo'shishning o'rin almashtirish qonuni:  $a + b = b + a$ .

O'qli kasrlar uchun qo'shishning guruhlash qonuni:  $(a + b) + c = a + (b + c)$ .

Bu qonunlarni mustaqil tavsiflang va misollarda tushuntirib bering.

Ba'zan qo'shish qonunlaridan foydalanish hisoblashlarni osonlashtirishi mumkin.

**8 – misol.** Hisoblang:  $4,23 + 2,57 + 5,77$ .

O'nli kasrlar uchun qo'shishning o'rin almashtirish qonunidan foydalanib oxirgi ikki qo'shiluvchilarning o'rnini almashtirib olamiz:

$$4,23 + 2,57 + 5,77 = 4,23 + 5,77 + 2,57.$$

O'nli kasrlar uchun guruhlash qonunidan foydalanib, qo'shiluvchilarni quyidagicha guruhlab olamiz va amallarni bajaramiz:

$$4,23 + 5,77 + 2,57 = (4,23 + 5,77) + 2,57 = 10 + 2,57 = 12,57.$$



### Savollarga javob bering!

1. O'nli kasrlar qanday qo'shiladi?
2. O'nli kasrlar qanday ayriladi?
3. O'nli kasrlarni «ustun» ko'rinishida qo'shish qoidasini tushuntiring.
4. Sonning xona birliklari bo'yicha yoyilmasi deb nimaga aytiladi?
5. Kasrning o'nli yozuvida verguldan keyingi: a) birinchi xona; b) ikkinchi xona; d) uchinchi xona; e) to'rtinchi xona qanday nomlanadi?
6. O'nli kasrlar xona birliklari bo'yicha qanday taqqoslanadi?
7. Sonlar nurida o'nli kasr xona birliklari qanday tasvirlanadi?



### Sinfda bajariladigan mashqlar

**819.** Omborga birinchi kuni 2,14 t, ikkinchi kuni esa 3,65 t yuk tushirildi. Bu ikki kun ichida omborga qancha yuk tushirilgan?

**820.** Yig'indini toping:

- a)  $3,8 + 6,1$ ;      b)  $0,02 + 0,01$ ;      d)  $1,23 + 9,77$ ;  
 e)  $0,003 + 0,006$ ;      f)  $1,02 + 0,99$ ;      g)  $24,2 + 0,8$ .

**821.** Yig'indini toping:

- a)  $8,23 + 2,18$ ;      d)  $82,12 + 54,42$ ;      f)  $10,32 + 10,01$ ;      h)  $6,79 + 2,99$ ;  
 b)  $11,35 + 6,47$ ;      e)  $4,22 + 10,82$ ;      g)  $0,321 + 0,346$ ;      i)  $94,514 + 26,465$ .

**822.** Yig'indini toping:

- a)  $6,83 + 5,1$ ;      d)  $82,1 + 5,42$ ;      f)  $10,52 + 10$ ;      h)  $67,9 + 2,99$ ;  
 b)  $1,3 + 6,47$ ;      e)  $4,20 + 0,8$ ;      g)  $1,3 + 0,346$ ;      i)  $4,259 + 22,64$ .

**823.** Ayirmani toping:

- a)  $9,5 - 6,1$ ;      b)  $12,23 - 9,12$ ;      d)  $8,9 - 3,6$ ;      e)  $24,7 - 0,3$ ;  
 f)  $0,06 - 0,02$ ;      g)  $0,008 - 0,001$ ;      h)  $1,01 - 0,99$ ;      i)  $42,53 - 2,53$ .

**824.** "Kaptiva" avtomobili "Orlando" avtomobilidan a) qanchaga uzun?  
 b) qanchaga baland?



**825.** Jadvalda berilgan ayirmalarni toping.

Har bir ayirmani pastdagi jadvaldan topib, uning pastidagi bo'sh katakka misolning mos harfini yozib chiqing. (Masalan, 1- misol (0,383–0,158) ning javobi – 0,225. Bu misolga mos harf «R» ni pastdagi jadvalda 0,225 sonining tagiga yozamiz).

Agar barcha ishlarni to'g'ri bajarsangiz, 2010- yili O'zbekiston astronomlari tomonidan kashf qilingan mitti sayyoraning nomini bilib olasiz.

R	0,383 – 0,158	Q	24,20 – 10,28	A	4,259 – 2,264
M	11,4 – 6,7	S	0,343 – 0,051	N	6,36 – 4,34
A	8,16 – 5,82	A	67,9 – 2,9	D	5,36 – 1,39

0,292	2,34	4,7	65	0,225	13,92	1,995	2,02	3,97
				R				



**826.** Jadvalni to'ldiring:

$a$	2,1	2,2	2,3		2,6	2,7	2,9
$b$	0,4	1,5		1,7			2,8
$a + b$			4,6	4		3,2	
$a - b$					0,6		

**827.** Miqdorlarni taqqoslang:

- a) 23,2–16,9; || e) 35,7–0,022; || h) 130,03–0,0023; || l) 2419–33,7024;  
 b) 2,34+298; || f) 1,38+0,00384; || i) 0,10005+0,01022; || m) 3 – 2,7561;  
 d) 76,2+112,6; || g) 0,0031–0,0017; || k) 102–100,998; || n) 1500–108,0053.

- 828.** a) Qaysi sondan 4,67 ayrilsa, 3,23 hosil bo'ladi?  
 b) Qaysi songa 2,89 qo'shilsa, 8,93 hosil bo'ladi?  
 d) 8,34 hosil bo'lishi uchun qaysi sonni 3,56 taga kamaytirish kerak?  
 e) 11,08 hosil bo'lishi uchun qaysi sonni 8,06 taga orttirish kerak?

**829.** Amallarni bajaring:

- a) 2,6 + 3,8 + 3,7 + 0,5; || b) 6,5 – 2,3 + 3,1 – 2,5;  
 d) 18 – (1,5 + 0,04) – 6,56; || e) (3,09 + 4,08) – (23 – 20,7).

**830.** Bu qaysi sonning xona birliklari bo'yicha yoyilmasi?

- a) 0,4 + 0,06 + 0,009; || b) 0,1 + 0,006 + 0,0003; || d) 8 + 0,5 + 0,01 + 0,005;  
 e) 4 + 0,1 + 0,02 + 0,0004; || f) 20 + 2 + 0,3 + 0,007; || g) 50 + 6 + 0,06 + 0,007.

**831.** O'nli kasrni xona birliklar bo'yicha yoying: a) 8,64; b) 7,532; d) 6,2703.

*Namuna:* 61,795 = 60 + 1 + 0,7 + 0,09 + 0,005.

**832.** 5 "A" sinf 2,72 t temir-tersak yig'di. 5 "B" sinf esa 5 "A" sinfdan 1,01 t kam temir-tersak yig'di. Ikkala sinf birgalikda qancha temir-tersak yig'gan?

833. Teploxod ko'lda 27 km/soat tezlik bilan 3 soat, so'ngra bu ko'lga quyiladigan daryoda oqimga qarshi 4 soat suzdi. Agar daryo oqimining tezligi 3 km/soat bo'lsa, teploxod shu 7 soatda bosib o'tgan masofani toping.



### Uyda bajariladigan mashqlar

834. Amalni bajaring va natijani tekshiring.

a) $\begin{array}{r} 17,82 \\ + 24,53 \\ \hline \end{array}$	b) $\begin{array}{r} 123,87 \\ + 68,5 \\ \hline \end{array}$	d) $\begin{array}{r} 54,56 \\ - 27,37 \\ \hline \end{array}$	e) $\begin{array}{r} 27,3 \\ - 9,52 \\ \hline \end{array}$
--	--	--	--

835. Amalni bajaring:

a)  $1,23 + 46,56$ ;    b)  $0,59 - 0,27$ ;    d)  $0,43 + 2,98$ ;    e)  $4,348 + 1,593$ ;  
 f)  $6,05 - 2,87$ ;    g)  $7,45 - 4,45$ ;    h)  $14,2 + 5,384$ ;    i)  $206,48 - 90,507$ .

836. Katerning oqim bo'yicha tezligi 23,7 km/soat. Agar oqimning tezligi 3,8 km/soat bo'lsa, katerning turg'un suvdagi tezligini va oqimga qarshi tezligini toping.

837. "Spark" avtomobili "Matiz" avtomobilidan a) qanchaga uzun? b) qanchaga baland?

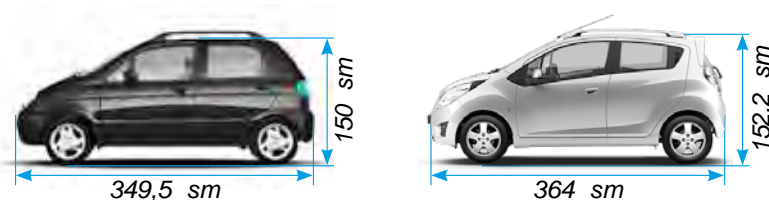

838. Amallarni bajaring:

a)  $83\,491 - (124\,821 : 207 + 2086) + 12\,763$ ;  
 b)  $146\,325 - (72\,306 - 1693) + 75\,014$ .

839. Mato ikki bo'lakka bo'lindi. Birinchi bo'lakning uzunligi 23,78 m. Ikkinchi mato bo'lagi birinchi bo'lakdan 10,56 metr uzun. Butun matoning uzunligi qancha?

840. Amallarni bajaring:

a)  $73,12 - (5,34 + 13,12)$ ;    b)  $101,3 + (84,7 + 34,23)$ ;  
 d)  $(47,28 - 34,98) + (55,02 + 34,98)$ ;    e)  $(46,83 + 15,77) - 16,83$ .

841. Sonning xona birliklari bo'yicha yoyilmasini yozing:

a) 8,36;    b) 1,268;    d) 0,2304;    e) 10,0105.



### Qiziqarli matematikaga oid masalalar

- a) Quyidagi sonlar yig'indisini toping:  $0,01 + 0,02 + 0,03 + \dots + 0,98 + 0,99$ .  
 b) Quyidagi sonlar ketma-ketligida qonuniyatni saqlagan holda uning keyingi 3 ta hadini yozing: 0,3; 0,4; 0,6; 0,9; 1,3; ...



38-§

**SONNING TAQRIBIY QIYMATI. SONLARNI YAXLITLASH**

1- rasmda tasvirlangan  $AB$  kesma uzunligi 3 sm ga,  $CD$  kesma uzunligi 3,1 sm ga va  $EF$  kesma uzunligi esa 2,8 sm ga teng. Bu kesmalardan faqat  $AB$  kesma uzunligi butun sonda ifodalangan. Qolganlarining uzunligi o'nli kasrlarda ifodalangan.

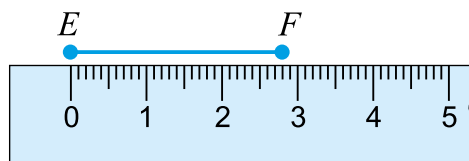
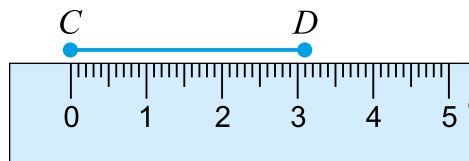
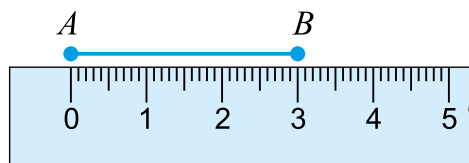

1- rasm

Shunday bo'lsa-da,  $CD$  kesma uzunligi haqida "ko'pi bilan 3 sm ga teng",  $EF$  kesma uzunligi haqida esa "kami bilan 3 sm ga teng" deb ham aytish mumkin. Bu kesmalar uzunligining taqribiy qiymatlaridir.

2- rasmdagi  $MN$  kesma uzunligi 3 sm va 4 sm oralig'ida ekanligini ko'rish mumkin. Demak, 3 sm –  $MN$  kesma uzunligining kami bilan, 4 sm – esa ko'pi bilan olingan va butun santimetrlarda ifodalangan taqribiy qiymatidan iborat bo'ladi.

Agar  $a < x < b$  bo'lsa,  $a$  soni –  $x$  ning *kami bilan taqribiy qiymati*,  $b$  soni –  $x$  ning *ko'pi bilan taqribiy qiymati* deb ataladi.

$MN$  kesma uzunligi 3,8 smga teng bo'lib, u 3 sm ga qaraganda 4 sm ga yaqinroq (chunki 3,8 dan 4 gacha bo'lgan masofa:  $4 - 3,8 = 0,2$  ga, 3,8 dan 3 gacha bo'lgan masofa esa:  $3,8 - 3 = 0,8$  ga teng bo'lib,  $0,2 < 0,8$ ). Shundan kelib chiqib,  $MN$  kesma uzunligi taxminan 4 sm ga teng deb olinadi.

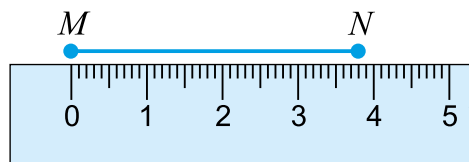

2- rasm

Bu holatda  $MN$  kesma uzunligi butungacha (birlar xonasigacha) yaxlitlandi deb ataladi va bu  $MN \approx 4$  sm tarzida yoziladi. Bu yerda " $\approx$ " belgi – "taqriban teng" deb o'qiladi.

Sonni unga eng yaqin bo'lgan butun songa almashtirish – *sonni butungacha yaxlitlash* deb ataladi.

3-rasmda bir necha sonlarni butungacha yaxlitlash ko'rsatilgan.

- a)  $3,05 \approx 3$ ;  $3,16 \approx 3$ ;  $3,34 \approx 3$  (chunki, bu sonlar 4 ga qaraganda 3 ga yaqinroq),
- b)  $3,68 \approx 4$ ;  $3,81 \approx 4$ ;  $3,92 \approx 4$  (chunki, bu sonlar 3 ga qaraganda 4 ga yaqinroq),
- c)  $3,5 \approx 4$  (3,5 soni 3 va 4 sonlaridan bir xil uzoqlikda va bu holda 3,5 sonini katta butun songacha ya'ni 4 gacha yaxlitlashga kelishilgan).

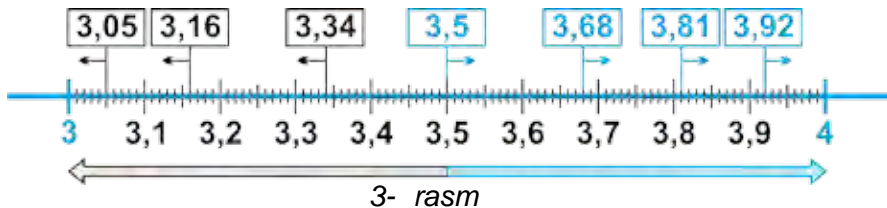

Sonlarni nafaqat butungacha, balki o'ndan birlar xonasigacha, yuzdan birlar xonasigacha, mingdan birlar xonasigacha va hokazo ixtiyoriy xonagacha yaxlitlash mumkin.

Masalan,

$0,23 \approx 0,2$  (o'ndan birlar xonasigacha yaxlitlash), chunki  $0,23$  soni  $0,3$  ga qaraganda  $0,2$  ga yaqinroq.

$2,337 \approx 2,34$  (yuzdan birlar xonasigacha yaxlitlash), chunki  $2,337$  soni  $2,33$  ga qaraganda  $2,34$  ga yaqinroq.

$8,562384 \approx 8,562$  (mingdan birlar xonasigacha yaxlitlash), chunki  $8,562384$  soni  $8,563$  ga qaraganda  $8,562$  ga yaqinroq.

$238 \approx 240$  (o'nlar xonasigacha yaxlitlash), chunki  $238$  soni  $230$  ga qaraganda  $240$  ga yaqinroq.

$45\ 849 \approx 45\ 800$  (yuzlar xonasigacha yaxlitlash), chunki  $45\ 849$  soni  $45\ 900$  ga qaraganda  $45\ 800$  ga yaqinroq.

$1\ 120\ 738 \approx 1\ 121\ 000$  (minglar xonasigacha yaxlitlash), chunki  $1\ 120\ 738$  soni  $1\ 120\ 000$  ga qaraganda  $1\ 121\ 000$  ga yaqinroq.

Umumiy holda quyidagi qoida o'rinli bo'ladi:

**!** Sonni biror xonagacha yaxlitlash uchun shu xonadan keyin kelgan barcha xona raqamlari 0 bilan almashtiriladi. Bunda,

- agar bu raqamlar verguldan keyin turgan bo'lsa, ular tashlab yuboriladi;

- agar birinchi tashlab yuborilgan yoki 0 bilan almashtirilgan raqam:

- a) 5, 6, 7, 8 yoki 9 bo'lsa, undan oldin kelgan raqamga 1 qo'shiladi;

- b) 0, 1, 2, 3 yoki 4 bo'lsa, undan oldin kelgan raqam o'zicha qoldiriladi.

**2- misol.**  $33,4623$  sonini o'ndan birlar xonasigacha yaxlitlang.

**Yechish.** O'ndan birlar xonasidan keyin kelgan 6, 2 va 3 raqamlarini tashlab yuboramiz. Chunki ular verguldan keyin turibdi.  $33,4$  ni hosil qilamiz. Chap tomondan birinchi bo'lib tashlab yuborilgan raqam 6 bo'lgani uchun undan oldin kelgan raqamga 1 ni qo'shamiz:  $4 + 1 = 5$ . Natijada  $33,5$  sonini hosil qilamiz. Demak,  $33,4623 \approx 33,5$ .

**3- misol.**  $1\ 206\ 845$  sonini minglar xonasigacha yaxlitlaylik.

**Yechish.** Minglar xonasidan keyin kelgan 8, 4, 5 raqamlarini 0 bilan almashtiramiz. Chap tomondan birinchi bo'lib 0 bilan almashtirilgan son 8 bo'lgani uchun undan oldin kelgan raqamga 1 ni qo'shamiz:  $6 + 1 = 7$ . Natijada  $1\ 207\ 000$  sonini hosil qilamiz. Demak,  $1\ 206\ 845 \approx 1\ 207\ 000$ .

**4- misol.**  $2149,56$  sonini o'nlar xonasigacha yaxlitlang.

**Yechish.**  $2149,56 \approx 2150$  (yaxlitlashni mustaqil izohlang).

## Savollarga javob bering!



1. Agar  $a < x < b$  bo'lsa,  $a$  va  $b$  sonlari  $x$  ning qanday qiymatlari deb ataladi?
2. Sonni butungacha yaxlitlash deganda nimani tushunasiz?
3. Sonni biror xonasigacha yaxlitlash qoidasini misolda tushuntirib bering.
4. Natural son va o'nli kasrlarni yaxlitlash nimasi bilan bir-biridan farq qiladi? Nimasi bilan bir-biriga o'xshaydi?

## Sinfda bajariladigan mashqlar



**842.** Quyidagi taqribiy tengsizliklarni o'qing. Sonlar qaysi xonagacha yaxlitlanganini aniqlang:

- a)  $5,38 \approx 5,4$ ;    b)  $82,761 \approx 82,76$ ;    d)  $121,3 \approx 121$ ;    e)  $2703,98 \approx 2700$ ;  
 f)  $8,3459 \approx 8,346$ ;    g)  $6,6601 \approx 6,7$ ;    h)  $7,5001 \approx 8$ ;    i)  $16,433 \approx 16,43$ .

**843.** Quyidagi o'nli kasr qanday ikkita ketma-ket kelgan natural sonlar orasida joylashgan? Kasr bu sonlardan qaysinisiga yaqinroq?

- a) 3,24;    b) 5,38;    d) 82,71;    e) 121,3;    f) 101,801.

*Namuna:* a)  $3 < 3,24 < 4$ . Bu son 3 ga yaqinroq, chunki 3 gacha bo'lgan masofa:  $3,24 - 3 = 0,24$ , 4 gacha bo'lgan masofa esa:  $4 - 3,24 = 0,76$  va  $0,24 < 0,76$ .

**844.** Tengsizliklarni o'qing. O'rtada turgan sonning kami bilan va ko'pi bilan olingan taqribiy qiymatlarini ayting. O'rtada turgan son ikki chekkada turgan sonlarning qaysi biriga yaqin?

- a)  $3 < 3,46 < 4$ ;    b)  $13 < 13,9 < 14$ ;    d)  $3,2 < 3,26 < 3,3$ ;    e)  $2,23 < 2,232 < 2,24$ .

**845.** Hisoblang va natijani birlar xonasigacha yaxlitlang:

- a)  $5,3 + 2,4$ ;    b)  $2,7 + 8,7$ ;    d)  $12,3 - 1,9$ ;    e)  $16,5 - 1,8$ ;  
 f)  $8,3 + 5,9$ ;    g)  $8,3 + 4,6$ ;    h)  $6,6 - 6,01$ ;    i)  $7,5 - 2,09$ .

**846.** O'nli kasrlarni yaxlitlang.

- a) o'ndan birlar xonasigacha:    0,364;    1,23;    0,919;    4,0785;  
 b) yuzdan birlar xonasigacha:    0,7348;    1,19105;    2,67903;    11,87412;  
 d) mingdan birlar xonasigacha:    2,9013;    0,07454;    3,2478;    0,9093;  
 e) yuzlar xonasigacha:    3242;    176082;    82352,14;    10032,983.

**847.** Filning massasi 5879 kg. Filning massasi taxminan necha tonna?



**848.** Yer sharining eng baland nuqtasi Jomolungma (yoki Everest) cho'qqisi bo'lib, uning balandligi 8848 m. Bu balandlikni kilometrgacha yaxlitlang.

**849.** Dunyoning eng chuqur joyi Tinch okeanidagi Mariana cho'kmasi hisoblanadi. Uning chuqurligi — 11 022 m. Bu chuqurlikni kilometrgacha yaxlitlang.

**850.** Dunyo aholisi 2014- yilga kelib 7 137 577 750 kishiga yetdi. Dunyo aholisi sonini: a) minggacha; b) milliongacha; d) milliardgacha yaxlitlang.

851. Yaxlitlash to'g'ri bajarilganmi?

- a)  $4,88 \approx 4,8$ ;      ||      d)  $8,761 \approx 8,77$ ;      ||      f)  $21,3 \approx 22$ ;  
 b)  $12,34 \approx 12,34$ ;      ||      e)  $3,6601 \approx 6,70$ ;      ||      g)  $3,5001 \approx 3$ .

852. Kasrlarni butungacha (birlar xonasigacha) yaxlitlang:

- a) 7,265; || b) 11,638; || d) 0,23; || e) 8,5; || f) 300,499; || g) 6,5108.

*Namuna:*  $45,834 \approx 46$  (Chunki, birlar xonasidan keyingi tashlab yuborilgan son 8. Shuning uchun birlar soni 5 ga 1 ni qo'shamiz).

853. Bir pud 16,38 kg ga teng. Agar u butun kilogrammgacha yaxlitlansa, necha kilogramm bo'ladi? O'ndan birgacha yaxlitlansa-chi?

854. Kasrlarni yaxlitlang:

- a) o'ndan birlar xonasigacha:    2,781;            3,1423;            203,962;    62,35;  
 b) yuzdan birlar xonasigacha:    0,07268;        1,35506;        10,081;        76,544;  
 d) o'nlar xonasigacha:            167,1;            2085,04;        444,4;        300,7.

855. Yaxlitlash to'g'ri bajarilgan bo'lishi uchun katakcha o'rniga qanday raqamlarni qo'yish mumkin:

- a)  $2,38 \square \approx 2,3$ ;      ||      b)  $1,3 \square \approx 1,4$ ;      ||      d)  $2,03 \square \approx 2,04$ ;  
 e)  $0, \square \approx 0$ ;      ||      f)  $5,60 \square \approx 5,60$ ;      ||      g)  $12,08 \square \approx 12,09$ .



### Uyda bajariladigan mashqlar

856. Tengsizliklarni o'qing. O'rtada turgan sonning kami bilan va ko'pi bilan olingan taqribiy qiymatlarini ayting. O'rtada turgan son ikki chekkadagi sonlardan qaysi biriga yaqin?

- a)  $5 < 5,32 < 6$ ;      ||      b)  $12,4 < 12,42 < 12,5$ ;      ||      d)  $1,37 < 1,378 < 1,38$ .

857. Kasrlarni yaxlitlang:

- a) o'ndan birlar xonasigacha:    42,281;            0,193;            3,932;            2,38;  
 b) yuzdan birlar xonasigacha:    0,0708;            31,3590;            0,0891;            6,597;  
 d) o'nlar xonasigacha:            476,1;            1039,02;            856,2;            1000,2.

858. Kasrlarni yaxlitlang:

- a) birlar xonasigacha:            1,69;            1,198;            37,444;            802,3032;  
 b) o'ndan birlar xonasigacha:    0,3691;            0,8218;            0,9702;            61,3501.

859. Toshkentdan Buxorogacha bo'lgan masofa 600 km. Bir vaqtning o'zida Toshkentdan 90 km/soat tezlik bilan yuradigan avtomobil, Buxorodan esa tezligi 110 km/soat bo'lgan ikkinchi avtomobil yo'lga chiqdi. Ular yo'lda necha soatdan keyin uchrashishadi?

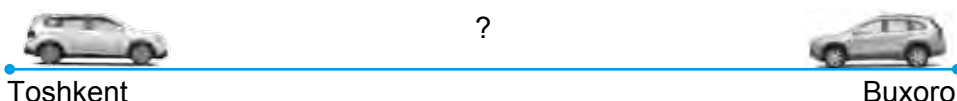

**860.** Quyidagi sonlar qaysi xonagacha yaxlitlangan? Ular to'g'ri yaxlitlanganmi?

- a)  $54,38 \approx 54,3$ ;      b)  $23,61 \approx 23,7$ ;      d)  $71,3 \approx 72$ ;  
 e)  $2,42 \approx 2,4$ ;      f)  $0,6601 \approx 0,70$ ;      g)  $63,901 \approx 64$ .

**861.** Amallarni bajaring:  $((37,3 + 21,7) \cdot 13 + 8688) : 31 - 196$ .

**862.** Yer shari ekvatorining uzunligi 40 075 696 m. Bu uzunlikni kilometrgacha yaxlitlang.

**863.** Dunyoda aholisi eng ko'p davlat Xitoy hisoblanadi. 2015-yil boshida bu mamlakat aholisi 1 370 811 348 kishini tashkil qildi. Xitoy aholisi sonini:

- a) minglar; b) millionlar; d) milliardlar xonasigacha yaxlitlang.

### Matematika tarixiga oid lavhalar



1. Dengizda masofa dengiz mili o'lchanadi. 1 dengiz mili 1,853 km ga teng. Bu sonni a) o'ndan birlar; b) birlar xonasigacha yaxlitlang. 1 dengiz mili taxminan necha kilometrga teng?
2. Qadimda yurtimizda masofa chaqirimlarda o'lchangan. 1 chaqirim taxminan 1,0688 km ga teng bo'lgan. Bu sonni: a) yuzdan birlar; b) o'ndan birlar; d) birlar xonasigacha yaxlitlang. 1 chaqirim taxminan necha kilometrga teng?

Qadimda dorixonalarda dorilar maxsus dorixona unsiyasida o'lchangan. 1 dorixona unsiyasi 31,1035 grammga teng bo'lgan. Bu sonni: a) yuzdan birlar; b) o'ndan birlar; d) birlar xonasigacha yaxlitlang. 1 dorixona unsiyasi taxminan necha grammga teng?

3. Angliyada massa o'lchov birligi sifatida funt ham ishlatiladi. 1 ingliz funti 0,45359237 kg ga teng. Bu sonni: a) mingdan birlar; b) yuzdan birlar; d) o'ndan birlar; e) birlar xonasigacha yaxlitlang. 1 funt taxminan necha grammga teng?

### Qiziqarli matematikaga oid masalalar



- 1)  $4 * 5$  yozuvdagi yulduzcha o'rniga nima qoyilsa, 4 dan katta, lekin 5 dan kichik son hosil bo'ladi?
- 2)  $1001 \cdot 1002 \cdot 1003 \cdot 1004 \cdot 1005 \cdot 1006 \cdot 1007 \cdot 1008 \cdot 1009$  ko'paytma qanday raqam bilan tugaydi?

- 864.** Uchta qopda 1,97 sr un bor. Birinchi va ikkinchi qopdagi un massasi teng. Uchinchi qopda esa birinchi qopga qaraganda 0,11 sr ko'p un bor. Har qaysi qopda qanchadan un bor?
- 865.** To'g'ri to'rtburchakning eni 14 sm bo'lib, u bo'yining  $\frac{2}{5}$  qismini tashkil qiladi. To'g'ri to'rtburchak yuzini toping.
- 866.** Stansiyadan 50 km/soat tezlik bilan yuk poyezdi jo'nadi. 3 soat o'tgach shu stansiyadan uning ketidan 80 km/soat tezlik bilan elektropoyezd jo'nadi. Elektropoyezd jo'naganidan necha soat keyin yuk poyezdini quvib yetadi?
- 867.** Oralaridagi masofa 782 km bo'lgan ikki shahardan ikki poyezd bir-biriga qarab turli vaqtda yo'lga chiqdi. Birinchi poyezd 52 km/soat, ikkinchisi 61 km/soat tezlik bilan yurdi. Birinchi poyezd 416 km yurganidan keyin ikkinchisi bilan uchrashdi. Poyezdlardan biri ikkinchisidan necha soat oldin yo'lga chiqqan?
- 868.** Bir kishi bozorga tuxum olib kelib, birinchi xaridorga tuxumlarning yarmini va yana bitta, ikkinchi xaridorga qolgan tuxumlarning yarmini va yana bitta tuxum sotdi. Shundan so'ng unda 14 ta tuxum qoldi. Sotuvchi bozorga hammasi bo'lib necha dona tuxum olib kelgan?
- 869.** Uchburchakning bir tomoni 83,6 sm, ikkinchi tomoni birinчисidan 14,8 sm, uchinchisi ikkinчисidan esa 8,6 sm ortiq. Uchburchakning perimetrini toping.
- 870.** Daryoning chuqurligi 5,78 m. Ko'prik qurish uchun ishlatiladigan ustun daryo tubidagi yerga 2,1 m qoqilgan bo'lib, u suv sathidan 5,41 m chiqib turadi. Ustunning uzunligi qancha?
- 871.** Ikki maydondan kartoshka hosili yig'ib olindi. Birinchi maydondan 195,7 t, ikkinчисidan esa birinchi maydonga qaraganda 72,8 t ko'p kartoshka yig'ildi. Ikkala maydondan necha tonna kartoshka yig'ib olingan?
- 872.** Bir to'p gazlamadan birinchi kuni 13,72 m, ikkinchi kuni 24,3 m, uchinchi kuni esa 18,28 m sotildi. Shunda, 3,7 m gazlama sotilmay qoldi. To'pda necha metr gazlama bo'lgan?
- 873.** Yo'l quruvchilarning bir guruhi yo'lni  $A$  qishloqdan, ikkinchi guruhi esa  $B$  qishloqdan bir-biriga qarab qurib kelmoqda. Birinchi guruh 7,5 km, ikkinchisi esa undan 1,3 km ortiq yo'l qurgandan so'ng yana 1,8 km yo'l qurilmay qoldi.  $A$  va  $B$  qishloqlar orasidagi masofani toping.
- 874.** Sirdaryo viloyatining hududi 5,1 ming  $\text{km}^2$  ni tashkil qiladi. Bu Navoiy viloyatining hududidan 105,7 ming  $\text{km}^2$ , Qoraqalpog'iston Respublikasining hududidan esa 159,8 ming  $\text{km}^2$  ga kam. Navoiy viloyati va Qoraqalpog'iston Respublikasi hududi necha ming kvadrat kilometrni tashkil qiladi?

875. Quyidagi rasmlarga ko'ra harakatga doir masalalar tuzing va ularni yeching.

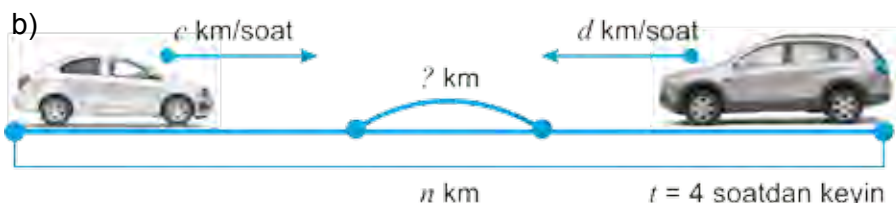
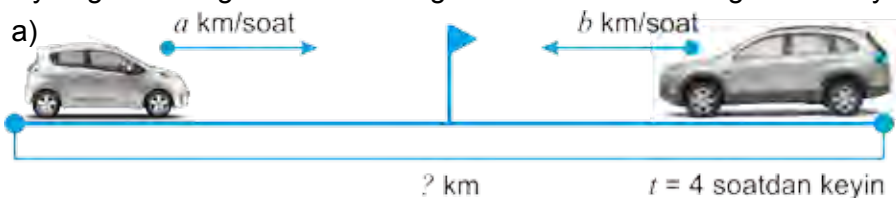

876. Velosipedchining tezligi 15 km/soat, piyodaning tezligi undan 9,7 km/soat kam. Agar ular bir-biriga qarab kelayotgan bo'lsa, ular bir-biriga qanday tezlik bilan yaqinlashmoqda?
877. Teploxodning o'z (turg'un suvdagi) tezligi 21,6 km/soat. Oqimning tezligi 4,9 km/soat. Teploxodning oqim bo'yicha va oqimga qarshi tezligini toping.
878. 6- sinf o'quvchilari 609,8 kg, 7- sinf o'quvchilari esa ulardan 75,5 kg ko'p olma terishdi. Har ikkala sinf o'quvchilari necha kilogramm olma terishgan?
879. Farhod 34,8 kg, Bahrom undan 4,7 kg ko'p, Dilshod esa Bahromga qaraganda 5,2 kg ko'p uzum uzdi. Bolalar jami bo'lib necha kilogramm uzum uzishgan?
880. Bir sayyoh ikki shahar orasidagi masofani 10 soatda, ikkinchisi esa 15 soatda bosib o'tadi. Agar ular shu shaharlardan bir-biriga qarab bir vaqtda yo'lga chiqsalar, necha soatdan keyin uchrashadilar?
881. Suvosti kemasi suv ostida suv ustidagiga qaraganda 17 marta ortiq masofani bosib o'tdi. Agar u suv ustida suv ostidagiga qaraganda 320 km kam yo'l bosgan bo'lsa, kema suv ostida qancha yo'l bosgan?
882. Ekskavator 4 soatda  $280 \text{ m}^3$  tuproq qazib chiqardi. Agar ekskavator kovshining hajmi  $2 \text{ m}^3$  bo'lsa, u har soatda necha kovsh tuproq qazib chiqargan?
883. Uchburchakning bir tomoni 8,65 dm bo'lib, u ikkinchi tomonidan 1,7 dm uzun. Agar uchburchakning perimetri 23,89 dm bo'lsa, uning uchinchi tomoni uzunligini toping.
884. To'rtta sonning yig'indisi 16,712 ga teng. Ikkinchi son 3,062 ga teng va u birinchi sondan 1,922 ga, uchinchi sondan esa 0,18 ga ortiq. To'rtinchi son ikkinchi sondan qancha ortiq?
885. Novvoyxonada non yopish uchun birinchi kuni 5,42 t, ikkinchi kuni birinchi kunga qaraganda 2,43 t, uchinchi kuni esa dastlabki ikki kundagiga qaraganda 3,21 t kam un ishlatildi. Novvoyxonada shu uch kunda jami qancha un ishlatilgan?

886. O'quvchiga matematika fani olimpiadasiga tayyorlanish uchun 150 ta masala berildi. O'quvchining yechgan masalalari yechmaganlaridan 4 marta ortiq bo'lsa, u nechta masala yechgan?
887. Hovuz 6 soatda suv bilan to'ladi. 1 soat 20 minutda hovuzning qanday qismi suv bilan to'ladi?
888. a) Yerning diametri 12 756 km bo'lib, bu Quyoshning diametridan taxminan 109 marta qisqa. Quyoshning diametrini toping.  
 b) Yerning diametri 12 756 km, Oyniki esa 3 474 km. Yer diametri Oy diametridan taxminan necha marta uzun?  
 d) Yerdan Quyoshgacha bo'lgan masofa taxminan 150 000 000 km. Oygacha bo'lgan masofa esa 384 400 km. Oy Quyoshga qaraganda Yerga taxminan necha marta yaqin?



### Bilimingizni sinab ko'ring!

Bu bob materiallarini o'rganib chiqib, quyidagi masalalarni yecha olishingiz shart! Nazorat ishi oldidan o'zingizni sinab ko'ring!

**Test.** To'g'ri javobni aniqlang.

- Sonni yaxlitlaganda, chap tomondan birinchi bo'lib tashlab yuborilgan raqam 8 bo'lsa, undan oldin kelgan raqam qanday o'zgaradi?  
 A. 1 ga ortadi; || B. 1 ga kamayadi; || D. O'zgarmaydi; || E. 10 ga ortadi.
- 1123,0956 sonining mingdan birlar xonasida qaysi raqam turibdi?  
 A. 1; || B. 6; || D. 5; || E. 0.
- 14,209653 sonini yuzdan birlar xonasigacha yaxlitlang.  
 A. 14,2096; || B. 14,2097; || D. 14,209; || E. 14,21.

### 9- nazorat ishi namunasi

- |                         |  |                             |
|-------------------------|--|-----------------------------|
| a) Sonlarni taqqoslang: |  | b) Kilometrlarda ifodalang: |
| 7,195 va 12,1;          |  | 2 km 156 m;                 |
| 8,276 va 8,3;           |  | 8 km 70 m;                  |
| 0,76 va 0,7598;         |  | 685 m;                      |
- Amallarni bajaring:  
 a)  $12,3 + 5,26$ ; || b)  $79,1 - 6,08$ ; || d)  $0,48 + 0,057$ ; || e)  $5 - 1,63$ .
- a) 3,18; 30,625; 257,51 va 0,28 sonlarni birlar xonasigacha yaxlitlang.  
 b) 0,531; 12,467; 8,5452 va 0,009 sonlarni yuzdan birlar xonasigacha yaxlitlang.
- Qayiqning o'z tezligi 3,4 km/soat, oqimga qarshi tezligi esa 0,8 km/soat. Qayiqning oqim bo'yicha tezligini toping.
- $m$  ning  $0,71 < m < 0,74$  shartni qanoatlantiruvchi 4 ta qiymatini yozing.



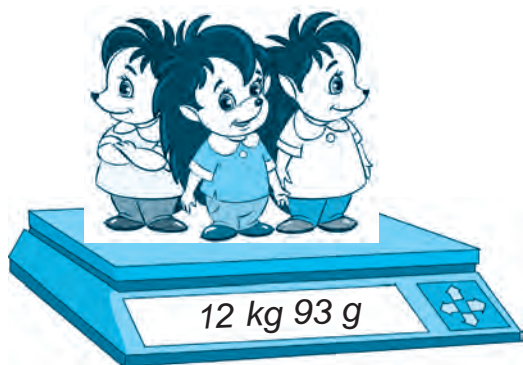

$$12,93 : 3 = 4,31$$

$$4,31 \cdot 3 = 12,93$$

$$12,93 : 4,31 = 3$$

## VII BOB. O'NLI KASRLARNI KO'PAYTIRISH VA BO'LISH

### 40-§.

### O'NLI KASRLARNI NATURAL SONGA KO'PAYTIRISH

Paxta maydoni kvadrat shaklida bo'lib, uning tomoni 1,14 km ga teng. Bu maydonning perimetrini topaylik. Malumki, bu maydon perimetri to'rtta tomon uzunliklari yig'indisi:  $1,14 + 1,14 + 1,14 + 1,14 = 4,56$  ga, ya'ni 4,56 km ga teng bo'ladi.

Masalani yechish uchun har biri 1,14 ga teng bo'lgan to'rtta qo'shiluvchining yig'indisini topdik. Bu yig'indi 1,14 sonining natural son 4 ga ko'paytmasi deb ataladi va  $1,14 \cdot 4$  tarzida yoziladi.

*O'nli kasrning natural songa ko'paytmasi* deb har biri o'nli kasrga teng, soni esa berilgan natural songa teng bo'lgan qo'shiluvchilar yig'indisiga aytiladi.

$1,14 \cdot 4$  ko'paytmani sonlarni «ustun» usulida ko'paytirib ham topish mumkin.

Buning uchun vergulga e'tibor bermay, 114 va 4 sonlarini ko'paytiramiz.

x	1,14	← Berilgan o'nli kasrda verguldan keyin 2 ta raqam bor.
	4	
	4,56	← 2 ta raqam ajratib vergul qo'yamiz.

O'nli kasrni natural songa ko'paytirish uchun

- uning verguliga e'tibor bermay, natural songa ko'paytiriladi;
- o'nli kasrda verguldan keyin nechta raqam bo'lsa, hosil bo'lgan ko'paytmada ham shuncha raqam o'ng tomondan vergul bilan ajratiladi.



*1-misol.*  $2,45 \cdot 12$  ko'paytmani topaylik.

Yuqoridagi qoidaga ko'ra, oldin 245 ni 12 ga ko'paytiramiz:

x	2,45	← Yuqoridagi qoidaga ko'ra, oldin 245 ni 12 ga ko'paytiramiz:
	12	
	490	
+	245	← Berilgan o'nli kasrda verguldan keyin 2 ta raqam bor. Ko'paytmaning o'ng tomonidan ham 2 ta raqamni vergul bilan ajratamiz.
	29,40	← Natijada $2,45 \cdot 12 = 29,40 = 29,4$ ni hosil qilamiz.

$$\begin{array}{r}
 6,245 \\
 \times 10 \\
 \hline
 000 \\
 + 6245 \\
 \hline
 62,450
 \end{array}$$

**2-misol.** a)  $6,245 \cdot 10$  ko'paytmani topaylik.

Yuqoridagi qoidaga ko'ra, oldin 6245 ni 10 ga ko'paytiramiz:

$$6245 \cdot 10 = 62450.$$

Berilgan o'nli kasrda verguldan keyin 3 ta raqam bor.

Ko'paytmaning o'ng tomonidan 3 ta raqamni vergul bilan ajratamiz  
va  $6,245 \cdot 10 = 62,450 = 62,45$  ni hosil qilamiz.

### Kichik tadqiqot ishi

a)  $6,245 \cdot 10 = ?$     ||    b)  $6,245 \cdot 100 = ?$     ||    d)  $6,245 \cdot 1000 = ?$

ko'paytmalarni hisoblang va natijani tengliklarning o'ng tomoniga yozing.

Hosil bo'lgan uchta tenglikni yaxshilab ko'zdan kechiring va quyidagi savollarga ketma-ket javob bering:

1) Har bir misolda birinchi ko'paytuvchi va ko'paytmadagi vergullar holati bir-biridan qanday farq qilyapti?

2) Ikkinchi ko'paytuvchilarda nechta nol bor?

3) Birinchi misolda vergul qancha xona va qaysi tomonga surilyapti? Ikkinchi misolda-chi? Uchinchi misolda-chi?

4) Vergulning qancha xonaga surilishi nimaga bog'liq bo'lyapti?

Yuqoridagi savollarga berilgan javoblarga asoslanib, o'nli kasrni 10, 100, 1000 va hokazo sonlarga ko'paytirish qoidasini tafsiflang. Bu kichik tadqiqotingiz xulosasi bo'ladi. Agar hamma savollarga to'g'ri javob berib, to'g'ri xulosa chiqargan bo'lsangiz, quyidagi qoidani qayta kashf etgan bo'lasiz:



**O'nli kasr hamda 10, 100, 1000 va hokazo (1 va bir necha nollardan iborat) sonlarning ko'paytmasini topish uchun bu sonlarda nechta nol bo'lsa, o'nli kasrdagi vergulni o'shancha xona o'ngga surish kifoya.**

Bu qoidaga ko'ra quyidagi ko'paytmalarni osongina topamiz:

$$5,86 \cdot 10 = 58,6 \quad (\text{o'nli kasrdagi vergulni } 1 \text{ xona o'ngga surdik),}$$

$$0,294 \cdot 100 = 29,4 \quad (\text{o'nli kasrdagi vergulni } 2 \text{ xona o'ngga surdik),}$$

$$0,013 \cdot 1000 = 13 \quad (\text{o'nli kasrdagi vergulni } 3 \text{ xona o'ngga surdik).}$$

Vergulni surayotganda o'nli kasrda yetarlicha raqamlar bo'lmasa, oldin o'nli kasr o'ng tomoniga yetarlicha nollar yoziladi (bilasizki, bu holda o'nli kasr o'zgartmaydi), so'ng vergul suriladi. Buni quyidagi misolda ko'rishimiz mumkin:

**3-misol.**  $4,95 \cdot 1000$  ko'paytmani hisoblaylik.

Ko'rib turganingizdek, 4,95 ning verguldan keyin 2 ta raqami bor, biz esa vergulni o'ng tomonga 3 ta xonaga surmoqchimiz. Shuning uchun oldin kasrning o'ng tomoniga bitta nol qo'yib, so'ng vergulni 3 xona o'ngga suramiz:

$$4,95 \cdot 1000 = 4,950 \cdot 1000 = 4950$$



### Savollarga javob bering!

1. O'nli kasrning natural songa ko'paytmasi deb nimaga aytiladi?
2. O'nli kasrni natural songa ko'paytirish qoidasini ayting va uni misollarda tushuntirib bering.
3. O'nli kasrni 10, 100, 1000 va hokazo sonlarga ko'paytirish qoidasini ayting va uni misollarda tushuntirib bering.

**Sinfda bajariladigan mashqlar**



**889.** Yig'indini oldin ko'paytmaga keltirib hisoblang:

a)  $2,7 + 2,7 + 2,7 + 2,7 + 2,7$ ; || b)  $0,35 + 0,35 + 0,35 + 0,35 + 0,35 + 0,35$ .

**890.** Hisoblang:

a)  $0,7 \cdot 8$ ; || b)  $0,15 \cdot 6$ ; || d)  $3,4 \cdot 4$ ; || e)  $2,5 \cdot 8$ ;  
f)  $5,4 \cdot 3$ ; || g)  $0,02 \cdot 12$ ; || h)  $3 \cdot 0,008$ ; || i)  $4 \cdot 0,061$ .

**891.** Quyidagi sonlar ko'paytmasida verguldan keyin nechta raqam bo'ladi?

a)  $2,42 \cdot 621$ ; || b)  $12,3 \cdot 455$ ; || d)  $12,467 \cdot 602$ ; || e)  $0,007 \cdot 68$ ;  
f)  $5,412 \cdot 303$ ; || g)  $52 \cdot 0,903$ ; || h)  $0,034 \cdot 12$ ; || i)  $1,05 \cdot 168$ .

**892.** Ko'paytmada unutilib qoldirilgan vergulni qo'ying.

a)  $1,43 \cdot 62 = 8866$ ; || b)  $32,4 \cdot 43 = 13932$ ; || d)  $2,64 \cdot 61 = 16104$ ;  
e)  $0,033 \cdot 68 = 2244$ ; || f)  $5,012 \cdot 33 = 165396$ ; || g)  $62 \cdot 0,503 = 31146$ ;  
h)  $0,074 \cdot 22 = 1628$ ; || i)  $2,03 \cdot 86 = 17458$ ; || j)  $28 \cdot 1,002 = 28056$ .

**893.** Ko'paytirishni bajaring:

a)  $0,213 \cdot 26$ ; || b)  $0,12 \cdot 25$ ; || d)  $12,25 \cdot 212$ ; || e)  $1,5 \cdot 830$ ;  
f)  $0,41 \cdot 23$ ; || g)  $1,2 \cdot 241$ ; || h)  $2,99 \cdot 102$ ; || i)  $13 \cdot 1,002$ ;  
j)  $790 \cdot 0,04$ ; || k)  $52 \cdot 0,003$ ; || l)  $1,7 \cdot 160$ ; || m)  $233 \cdot 0,003$ .

**894.** Agar  $6,4 \cdot 17 = 108,8$  ekanligi ma'lum bo'lsa, quyidagi ko'paytmani toping:

a)  $64 \cdot 17$ ; || b)  $6,4 \cdot 170$ ; || e)  $640 \cdot 17$ ; || f)  $64 \cdot 170$ ;

**895.** a) 25,1; 0,56; 120,1; 75,9 sonlarini 6 marta orttiring;

b) 13,5; 2,35; 83,52; 7,003 sonlarini 8 marta orttiring.

**896.** Poyezd 95 km/soat tezlik bilan 2,5 soatda necha kilometr yuradi? 0,8 soatda-chi?

**897.** Abdullayevlar oilasining o'tgan yilgi jami daromadi 5 600 000 so'mni tashkil qilgan. Bu yilda e'sa bu ko'rsatkich 1,2 marta oshgan. Bu yili Abdullayevlar oilasining daromadi necha so'mni tashkil qilgan?



**898.** Hisoblang:

a)  $6,42 \cdot 10$ ; ||  $0,17 \cdot 10$ ; ||  $3,8 \cdot 10$ ; ||  $0,1 \cdot 10$ ; ||  $0,01 \cdot 10$ ;  
b)  $6,387 \cdot 100$ ; ||  $20,35 \cdot 100$ ; ||  $0,006 \cdot 100$ ; ||  $0,75 \cdot 100$ ; ||  $0,1 \cdot 100$ ;  
d)  $45,48 \cdot 1000$ ; ||  $7,8 \cdot 1000$ ; ||  $0,00081 \cdot 1000$ ; ||  $0,006 \cdot 1000$ ; ||  $0,12 \cdot 10\ 000$ .

**899.** a) 0,4 soni 0,04; 0,004; 0,0004 sonlaridan necha marta katta?

b) 348,1 soni 34,81; 0,3481; 0,03481 sonlaridan necha marta katta?

d) 546 soni 0,0546; 0,546; 54,6 sonlaridan necha marta katta?

**900.** Tushirib qoldirilgan nollar va vergulni qo'ying:

a)  $0,008 \cdot 11 = \dots 88$ ; || d)  $0,2 \cdot 41 = \dots 82$ ; || f)  $0,004 \cdot 15 = \dots 60$ .

b)  $0,04 \cdot 2 = \dots 8$ ; || e)  $0,05 \cdot 20 = \dots 100$ ; || g)  $0,008 \cdot 25 = \dots 200$ .

*Namuna:*  $0,3 \cdot 1,5 = 0,45$ ;

**901.** Ifodani ko'paytma shaklida tasvirlang:

a)  $7,6k + 3,4k$ ; || b)  $25,3y + 4,11y$ ; || d)  $8,92x - 5,92x$ ; || e)  $64a - 0,8a$ .

*Namuna:*  $7,6z + 3,4z = (7,6 + 3,4) \cdot z = 11z$

902. a)  $x = 8$  va  $y = 10$  bo'lganda,  $5,2x + 1,73y$  ifoda qiymatini toping;  
 b)  $a = 85$  va  $b = 10$  bo'lganda,  $16,52a + 18,1b$  ifoda qiymatini toping.
903. Hisoblang:  
 a)  $84,25 \cdot 3$ ;    b)  $0,125 \cdot 312$ ;    d)  $(4,8 + 3,5) \cdot 5$ ;    e)  $(18,6 - 9,1) \cdot 3$ .
904. Konchilarning birinchi brigadasi 2302 t ko'mir qazib oldi. Ikkinchi brigada birinchisidan 1,4 marta ko'p, uchinchi esa ikkinchisidan 540 t kam ko'mir qazib oldi. Uchala brigada qancha ko'mir qazib olgan?
905. Birinchi dalaning yuzi 103,6 gektar, ikkinchisining yuzi undan 32 gektar ortiq. Birinchi dalaning har gektaridan 38 sr, ikkinchisining har gektaridan 32 sr bug'doy hosili olingan bo'lsa, ikkala daladan qancha hosil olingan?



### Uyda bajariladigan mashqlar

906. Yig'indini oldin ko'paytmaga keltirib, keyin hisoblang:  
 a)  $4,9 + 4,9 + 4,9 + 4,9 + 4,9 + 4,9 + 4,9 + 4,9 + 4,9$ ;  
 b)  $1,73 + 1,73 + 1,73 + 1,73 + 1,73 + 1,73 + 1,73 + 1,73 + 1,73$ .
907. Quyidagi sonlar ko'paytmasida verguldan keyin nechta raqam bo'ladi?  
 a)  $7,49 \cdot 691$ ;    b)  $0,003 \cdot 61$ ;    d)  $0,024 \cdot 17$ ;  
 e)  $19,463 \cdot 607$ ;    f)  $57 \cdot 0,902$ ;    g)  $11111 \cdot 1,0007$ .
908. Quyidagi sonlar ko'paytmasida unutilib qoldirilgan vergulni qo'ying.  
 a)  $1,42 \cdot 69 = 9698$ ;    b)  $0,022 \cdot 61 = 1342$ ;    d)  $0,034 \cdot 99 = 3366$ ;  
 e)  $9,64 \cdot 61 = 58804$ ;    f)  $69 \cdot 0,502 = 34638$ ;    g)  $91 \cdot 1,007 = 91637$ .
909. Ko'paytirishni bajaring:  
 a)  $7,1 \cdot 61$ ;    b)  $0,91 \cdot 57$ ;    d)  $19,5 \cdot 1$ ;    e)  $0,4 \cdot 29$ ;  
 i)  $0,14 \cdot 3$ ;    f)  $2,9 \cdot 40$ ;    g)  $0,6 \cdot 91$ ;    j)  $0,22 \cdot 50$ .
910. Ko'paytirishni bajaring:  
 a)  $0,912 \cdot 76$ ;    b)  $17,75 \cdot 919$ ;    d)  $1,5 \cdot 120$ ;    e)  $0,41 \cdot 92$ ;  
 f)  $9,99 \cdot 107$ ;    g)  $390 \cdot 0,04$ ;    h)  $12 \cdot 1,009$ ;    i)  $1,3 \cdot 160$ .



911. Hisoblang:  
 a)  $3,22 \cdot 10$ ;     $0,45 \cdot 10$ ;     $6,9 \cdot 10$ ;     $0,3 \cdot 10$ ;     $0,08 \cdot 10$ ;  
 b)  $1,257 \cdot 100$ ;     $40,78 \cdot 100$ ;     $0,005 \cdot 100$ ;     $0,23 \cdot 100$ ;     $0,6 \cdot 100$ ;  
 d)  $15,32 \cdot 1000$ ;     $5,1 \cdot 1000$ ;     $0,00029 \cdot 1000$ ;     $0,003 \cdot 1000$ ;     $0,72 \cdot 10\ 000$ .
912. 1) 153,2 soni a) 15,32, b) 0,1532, d) 0,01532 sonlaridan necha marta katta?  
 2) 21,7 soni a) 2,17, b) 0,217, d) 0,0217 sonlaridan necha marta katta?
913. Agar  $8,7 \cdot 13 = 113,1$  ekanligi ma'lum bo'lsa, quyidagi ko'paytmani toping:  
 a)  $87 \cdot 13$ ; b)  $8,7 \cdot 130$ ; d)  $0,87 \cdot 13$ ; e)  $870 \cdot 13$ ; f)  $87 \cdot 130$ ; g)  $0,087 \cdot 13$ .
914. a) 75,1; 0,56; 190,1; 35,7 sonlarini 7 marta orttiring;  
 b) 12,5; 7,25; 12,59; 3,002 sonlarini 12 marta orttiring.
915. Bir xil yo'nalishda harakatlanayotgan yuk poyezdining tezligi 1,2 km/min, yo'lovchi poyezdining tezligi 1,5 km/min. Agar yo'lovchi poyezdi yuk poyezdini 21 minutdan keyin quvib yetsa, hozir ular orasidagi masofa qancha?
916. Viloyat sport musobaqalarida 5842 nafar o'quvchi qatnashdi. Sportchi o'g'il bolalar soni qiz bolalar sonidan 268 ta ortiq. Musobaqalarda necha nafar o'g'il bola va nechta qiz bola qatnashgan?

41-§.

**O'NLI KASRLARNI NATURAL SONGA BO'LISH**

*1- misol.* Uzunligi 16,8 m bo'lgan gazlama 6 ta teng bo'lakka bo'lindi. Har bir bo'lak uzunligini toping.

*Yechish:* Masalani yechish uchun oldin gazlama uzunligini detsimetrlarda ifodalaymiz:  $16,8 \text{ m} = 168 \text{ dm}$ .

$168 : 6 = 28$  bo'lgani uchun gazlama bitta bo'lagining uzunligi 28 dm ya'ni 2,8 m ga teng bo'ladi.

*Tekshirish:* 2,8 ni 6 ga ko'paytirsak, 16,8 hosil bo'ladi. Demak, bo'linma to'g'ri topilgan.

*Javob:* Har bir bo'lak uzunligi 2,8 m ga teng.

Shunday qilib, 16,8 ni 6 ga bo'lganda, bo'linma 2,8 ga teng bo'ldi.

Bu  $16,8 : 6 = 2,8$  tarzida yoziladi.

*O'nli kasrni natural songa bo'lish* deb shunday sonni topishga aytiladiki, uni natural songa ko'paytirganda berilgan kasr hosil bo'lsin.

Yuqoridagi masalani berilganlarni detsimetrlarga o'tkazmasdan ham yechish mumkin.

*2- misol.* 16,8 ni 6 ga «burchak» usulida bo'laylik.

Buning uchun vergulga e'tibor bermasdan, 168 ni 6 ga «burchak» usulida bo'lish va sonning butun qismini bo'lish tugagan zahoti bo'linmaga vergul qo'yish kerak bo'ladi. So'ng bo'lishni davom ettirish kerak bo'ladi. Haqiqatan ham,

$$\begin{array}{r|l} 16,8 & 6 \\ \hline 12 & 2 \\ \hline 4 & \end{array}$$

Sonning butun qismini bo'lish tugadi. Bo'linmada turgan sondan keyin vergul qo'yamiz va bo'lishni davom ettiramiz.

$$\begin{array}{r|l} 16,8 & 6 \\ \hline 12 & 2,8 \\ \hline 48 & \\ \hline 48 & \\ \hline 0 & \end{array}$$

**O'nli kasrni natural songa bo'lish uchun**

- uning verguliga e'tibor bermay natural songa bo'linadi;
- butun qismini bo'lish tugagan zahoti bo'linmaga vergul qo'yiladi va bo'lish davom ettiriladi.



Agar o'nli kasrning butun qismi natural sondan kichik bo'lsa, bo'linmaning butun qismi noldan iborat bo'ladi.

Buni quyidagi misolda ham ko'rish mumkin.

*3- misol.* 1,84 ni 8 ga «burchak» usulida bo'laylik.

*Tushuntirish.* Bo'linuvchining butun qismi 1 ga teng bolib, u bo'luvchidan kichik. Shuning uchun bo'linmaga 0 butun qo'ydik va uni vergul bilan ajratdik.

So'ng bo'lishni odatdagidek davom ettirdik va  $1,84 : 8 = 0,23$  natijaga keldik.

*4- misol.* 41,85 ni 18 ga «burchak» usulida bo'laylik.

*Tushuntirish.* Bo'linuvchining barcha raqamlarini pastga olib tushganimizdan keyin ham qoldiqda 0 hosil bo'lmadi. Lekin biz o'nli kasrning o'ng tomoniga qancha 0 yozgan bilan kasr o'zgarmligini bilamiz. Shundan kelib chiqib, bo'lishni

$$\begin{array}{r|l} 1,84 & 8 \\ \hline 1,6 & 0,23 \\ \hline 24 & \\ \hline 24 & \\ \hline 0 & \end{array}$$

$$\begin{array}{r}
 41,850 \overline{) 18} \\
 \underline{36} \phantom{0} \\
 58 \phantom{0} \\
 \underline{54} \phantom{0} \\
 45 \phantom{0} \\
 \underline{36} \phantom{0} \\
 90 \phantom{0} \\
 \underline{90} \\
 0
 \end{array}$$

davom ettirish uchun bo'linuvchining o'ng tomoniga birin-ketin 0 larni qo'yib boramiz va bo'linmaning keyingi raqamlarini topib boramiz. Bizning holda bitta 0 ni qo'yish yetarli bo'ldi.

Natijada  $41,85 : 18 = 2,325$  ekanligini topdik.

**5- misol.** 38,3 ni 10 ga bo'laylik.

Ma'lumki, bo'lish amali ma'nosiga ko'ra bo'linmani 10 ga ko'paytirganda bo'linuvchi hosil bo'lishi kerak. Shuningdek, o'nli kasrni 10 ga ko'paytirishda vergul

bitta xona o'ngga suriladi.

Demak, o'nli kasrni 10 ga bo'lganda vergul bitta xona chapga surilar ekan:  $38,3 : 10 = 3,83$ .

### Kichik tadqiqot ishi

- a)  $21,9 : 10 = ?$                       b)  $21,9 : 100 = ?$                       d)  $21,9 : 1000 = ?$

bo'linmalarni toping va natijani tengliklarning o'ng tomoniga yozing.

Hosil bo'lgan uchta tenglikni yaxshilab ko'zdan kechiring va quyidagi savollarga ketma-ket javob bering:

1) Har bir misolda bo'linuvchi va bo'linmadagi vergullar holati bir-biridan qanday farq qilyapti?

2) Bo'luvchilarda nechta nol bor?

3) Birinchi misolda vergul necha xona va qaysi tomonga surilyapti? Ikkinchi misolda-chi? Uchinchi misolda-chi?

4) Vergulning necha xonaga surilishi nimaga bog'liq bo'lyapti?

Yuqoridagi savollarga berilgan javoblarga asoslanib, o'nli kasrni 10, 100, 1000 va hokazo sonlarga bo'lish qoidasini tavsiflang. Bu — kichik tadqiqotingiz xulosasi bo'ladi.

Agar hamma savollarga to'g'ri javob berib, to'g'ri xulosa chiqargan bo'lsangiz, quyidagi qoidani qayta kashf etgan bo'lasiz:



**O'nli kasrni 10, 100, 1000 ... va hokazo sonlarga bo'lish uchun bo'luvchida birdan keyin nechta nol bo'lsa, o'nli kasrdagi vergulni ham shuncha xona chapga surish kifoya.**

Bu qoidaga ko'ra quyidagi bo'linmalarni osongina topamiz:

$35,6 : 10 = 3,56$  (o'nli kasrdagi vergulni 1 xona chapga surdik),

$527,4 : 100 = 5,274$  (o'nli kasrdagi vergulni 2 xona chapga surdik)

$2167,1 : 1000 = 2,1671$  (o'nli kasrdagi vergulni 3 xona chapga surdik).

O'nli kasrning butun qismida vergulni surishda raqamlar yetarli bo'lmasa, oldin o'nli kasrning chap tomoniga yetarlicha nollar yoziladi (bilasizki, bu holda o'nli kasr o'zgarmaydi), so'ng vergul suriladi. Buni quyidagi misolda ko'rishimiz mumkin:

**6- misol.**  $24,5 : 1000$  bo'linmani hisoblaylik.

Ko'rib turganingizdek, 24,5 ning butun qismida 2 ta raqam bor, biz esa vergulni chap tomonga 3 ta xonaga surmoqchimiz. Shuning uchun oldin

kasrning chap tomoniga bitta nol qo'yib, so'ng vergulni 3 xona chapga suramiz. Albatta, bu holda bo'linmaning butun qismi 0 ga teng bo'ladi:  $24,5 : 1000 = 024,5 : 1000 = 0,0245$ ;

Ba'zida katta natural sonlar bilan ish ko'rganda ularni minglarda yoki millionlarda ifodalashga to'g'ri keladi.

**7- misol.** 14 500 sonini minglarda ifodalaylik.

Buning uchun 14 500 sonini 1000 ga bo'lib, 1000 ga ko'paytiramiz (bu bilan sonning qiymati o'zgarmaydi):  $(14500 : 1000) \cdot 1000$ . Qavs ichidagi son 14,5 ga teng.

Demak,  $14\ 500 = 14,5 \cdot 1000$ . Oxirgi ko'paytuvchi 1000 ni raqamlar bilan emas, nomini so'z bilan yozamiz. Natijada,  $14\ 500 = 14,5$  ming degan natijaga kelamiz.

Xuddi shunga o'xshash, natural sonni millionlarda ifodalaganda ham shu yo'l tutiladi. Masalan,  $28\ 300\ 000 = (28\ 300\ 000 : 1\ 000\ 000) \cdot 1\ 000\ 000 = 28,3 \cdot 1\ 000\ 000 = 28,3$  million.

Ba'zi hollarda bo'lish yordamida berilgan oddiy kasrga teng bo'lgan o'nli kasrni topish mumkin. Boshqacha qilib aytganda, bo'lish yordamida oddiy kasrni o'nli kasrga aylantirish mumkin.

**8- misol.**  $\frac{3}{5}$  kasrni o'nli kasrga aylantiring.

**Yechish:** Ma'lumki,  $\frac{3}{5}$  kasr 3 ni 5 ga bo'lganda hosil bo'lgan bo'linmadir. 3 ni 5 ga «burchak» usulida bo'lib, 0,6 o'nli kasrni hosil qilamiz. Demak,  $\frac{3}{5} = 0,6$ .

### Savollarga javob bering!



1. O'nli kasrni natural songa bo'lish deganda nimani tushunasiz?
2. O'nli kasrni natural songa bo'lish qoidasini ayting va uni misollarda tushuntirib bering.
3. Agar kasrning butun qismi bo'luvchidan kichik bo'lsa, bo'linmaning butun qismi nimaga teng bo'ladi?
4. O'nli kasrni 10, 100, 1000 va hokazo sonlarga bo'lish qoidasini ayting va uni misollarda tushuntiring.
5. Katta natural sonlar minglarda yoki millionlarda qanday ifodalanadi?

### Sinfda bajariladigan mashqlar



**917.** Uzunligi 26,8 m bo'lgan sim 8 ta teng bo'lakka bo'lindi. Har bir bo'lak uzunligini toping. Masalani oldin berilganlarni santimetrغا o'tkazib, so'ng onli kasrni natural songa bo'lish qoidasiga ko'ra yeching. Natijalarni o'zaro taqqoslang.

**918.** Bo'linmani toping:

- |                   |                      |                   |                  |
|-------------------|----------------------|-------------------|------------------|
| a) $42,3 : 9$ ;   | b) $121,6 : 4$ ;     | d) $93,15 : 23$ ; | e) $18,27 : 7$ ; |
| f) $172,8 : 12$ ; | g) $1\ 59,84 : 72$ ; | h) $14,4 : 12$ ;  | i) $44,8 : 4$ .  |

**Namuna:** Mazkur bandda yechilgan 2- misol.

919. Bo'linmani toping:

- a)  $2,34 : 9$ ;      b)  $1,68 : 4$ ;      d)  $93,15 : 23$ ;      e)  $3,57 : 7$ ;  
 f)  $10,824 : 12$ ;      g)  $36,72 : 72$ ;      h)  $4,8 : 12$ ;      i)  $3,48 : 4$ .

*Namuna:* Mazkur bandda yechilgan 3- misol.

920. Bo'linmani toping:

- a)  $5,87 : 2$ ;      b)  $10,63 : 2$ ;      d)  $3,42 : 4$ ;      e)  $10,4 : 5$ ;  
 f)  $13,8 : 15$ ;      g)  $24,4 : 8$ ;      h)  $14,7 : 12$ ;      i)  $44,5 : 4$ .

*Namuna:* Mazkur bandda yechilgan 4- misol.

921. a) Elektr choynak 1 soatda 1,2 kilovatt elektr quvvatini iste'mol qiladi. 1 litr suv bu choynakda 5 minutda qaynaydi. Bunga necha kilovatt-soat elektr energiyasi sarflanadi?

b) Elektr plita 1 soatda 1,5 kilovatt elektr quvvatini iste'mol qiladi. 1 litr suv plitada 13 minutda qaynaydi. Bunga necha kilovatt-soat elektr energiyasi sarflanadi?

d) Yuqoridagi masalalarda 1 litr suvni qaynatish necha so'mga tushishini hisoblang (1 kilovatt-soat elektr energiyasi narxi taxminan 150 so'm). Suvni nimada qaynatish arzon ekanligi haqida xulosa chiqaring.

922. Hisoblang:

- a)  $4,42 : 10$ ;       $0,57 : 10$ ;       $8,8 : 10$ ;       $0,5 : 10$ ;       $0,05 : 10$ ;  
 b)  $4,387 : 100$ ;       $26,35 : 100$ ;       $0,002 : 100$ ;       $0,35 : 100$ ;       $0,2 : 100$ ;  
 d)  $55,48 : 1000$ ;       $9,8 : 1000$ ;       $0,00091 : 1000$ ;       $0,003 : 1000$ ;       $0,52 : 10\ 000$ .

923. a) 0,0003 soni 0,3; 0,03; 0,003 sonidan necha marta kichik?

b) 0,0 2481 soni 24,81; 0,2481; 248,1 sonidan necha marta kichik?

d) 0,0746 soni 746; 0,746; 74,6 sonlaridan necha marta kichik?

924. Rasm asosida tenglama tuzing va uni yeching:

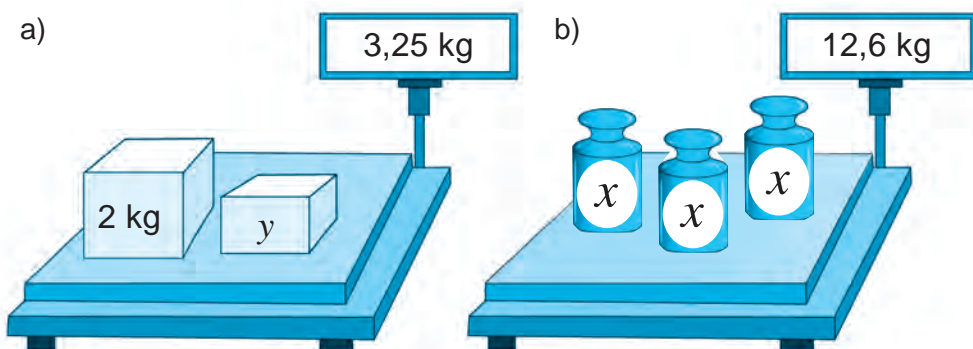

925. Kasrni o'nli ko'rinishda ifodalang:

- a)  $\frac{3}{4}$ ;      b)  $\frac{5}{8}$ ;      d)  $\frac{7}{4}$ ;      e)  $\frac{83}{25}$ ;      f)  $5\frac{1}{2}$ ;      g)  $70\frac{3}{75}$ .



*Namuna:* Mazkur bandda yechilgan 5-misol.



- 926.** Katakchalarning o'rniga ko'paytirish yoki bo'lish belgisini yozing.
- |                                |                                 |                                  |
|--------------------------------|---------------------------------|----------------------------------|
| a) $8,8 \square 10 = 88$ ;     | e) $44,55 \square 10 = 4,455$ ; | h) $0,36 \square 100 = 36$ ;     |
| b) $7,5 \square 100 = 750$ ;   | f) $10,5 \square 10 = 1,05$ ;   | i) $3,78 \square 100 = 0,0378$ ; |
| d) $3,3 \square 100 = 0,033$ ; | g) $0,37 \square 10 = 3,7$ ;    | j) $5,18 \square 100 = 0,518$ .  |
- 927.** Tushirib qoldirilgan sonlarni yozing.
- |                               |                              |                                 |
|-------------------------------|------------------------------|---------------------------------|
| a) $42,3 \cdot \dots = 423$ ; | e) $8 : \dots = 0,08$ ;      | h) $0,007 \cdot \dots = 0,07$ ; |
| b) $16,7 : \dots = 1,67$ ;    | f) $3,8 \cdot \dots = 380$ ; | i) $0,6 : \dots = 0,06$ ;       |
| d) $0,05 \cdot \dots = 50$ ;  | g) $1,3 : \dots = 0,0013$ ;  | j) $1,3 : \dots = 0,13$ .       |
- 928.** Sonni millionlarda ifodalang:  
a) 43 000 000;    b) 8 900 000;    d) 12 550 000;    e) 674 345 000.
- 929.** Dengizchilar masofani dengiz milida yoki futlarda ham o'lchashadi. 1 dengiz mili 6080 fut yoki 1853,2 m ga teng. a) 12 dengiz mili necha futga teng bo'ladi?; b) 3,6 dengiz mili necha m bo'ladi?
- 930.** Qadimda odamlar masofani chaqirimlarda o'lchashgan. 1 chaqirim 1066,78 m ga teng bo'lgan. 23 chaqirim necha m ni tashkil qiladi?
- 931.** Kompyuter monitori to'g'ri to'rtburchak shaklida bo'lib, uning kattaligi to'g'ri to'rtburchak diagonali uzunligiga qiyoslanib dyuymlarda o'lchanadi. Agar 1 dyuym 25,4 mm bo'lsa, a) 17; b) 21 dyuymli kompyuter monitorining diagonali necha mm bo'ladi? Natijani sm da ifodalang.
- 932.** Ikki qutida 12,8 kg choy bor. Agar birinchi qutidan ikkinchisiga 0,4 kg choy olib solinsa, ikkala qutidagi choy massasi tenglashadi. Har qaysi qutida qancha choy bor?
- 933.** Bir to'g'ri to'rtburchakning tomonlari 22 sm va 4,8 sm. Ikkinchi to'g'ri to'rtburchakning yuzi birinchisining yuzidan 11 marta kichik. Agar ikkinchi to'g'ri to'rtburchakning bo'yi 6 sm bo'lsa, uning enini toping.

### Uyda bajariladigan mashqlar



- 934.** Bo'linmani toping:
- |                  |                 |                  |
|------------------|-----------------|------------------|
| a) $53,5 : 5$ ;  | b) $1,75 : 7$ ; | d) $0,48 : 6$ ;  |
| e) $13,2 : 24$ ; | f) $0,7 : 25$ ; | g) $7,9 : 316$ . |
- 935.** Ifodaning qiymatini toping:
- |   |                                   |
|---|-----------------------------------|
| a) $0,25 : 4 + 15,3 : 5 + 12,4 : 8 + 0,15 : 30$ ; | b) $(1,24 + 3,56) : 16$ ;         |
| d) $2,28 + 3,72 : 12$ ;                           | e) $3,6 + 2,4 : (11,71 - 3,71)$ . |
- 936.** Hisoblang:
- |   |                    |                    |
|---|--------------------|--------------------|
| a) $6,387 : 100$ ; $226,35 : 100$ ; $0,005 : 100$ ; | $0,65 : 100$ ;     | $0,9 : 100$ ;      |
| b) $85,48 : 1000$ ; $1,8 : 1000$ ;                  | $0,00031 : 1000$ ; | $0,004 : 1000$ ;   |
|   |                    | $0,62 : 10\ 000$ . |
- 937.** a) 0,0 8431 soni 84,31; 0,8431; 843,1 sonidan necha marta kichik?  
b) 0,0125 soni 1,25; 0,125; 12,5 sonidan necha marta kichik?
- 938.** Sonlarni minglarda ifodalang: 320 000; 75 000; 15 700; 365 240; 1 875 900.



939. Tenglamani yeching:

a)  $15x = 0,15$ ;

b)  $3,08 : y = 4$ ;

d)  $295,1 : (x - 3) = 13$ ;

e)  $534 \cdot (x + 1,2) = 961,2$ .

940. Do'konda uch kunda 1240,8 kg un sotildi. Birinchi kuni 543 kg, ikkinchi kuni uchinchi kunga qaraganda 2 marta ko'p un sotildi. Uchinchi kuni necha kg un sotilgan?

941. Bitta qovoq necha kilogramm?

a)



b)



942. Uch o'tloqdan 28,6 t pichan yig'ildi. Birinchi va ikkinchi o'tloqdan baravardan, uchinchi o'tloqdan esa oldingi ikkitasining har biriga qaraganda 3,4 t ortiq pichan yig'ildi. Har qaysi o'tloqdan qancha pichan yig'ilgan?

943. Velosipedchi shahardan soatiga 13,4 km/soat tezlik bilan yo'lga chiqdi. Undan 2 soat keyin ikkinchi velosipedchi jo'nadi va 4 soatda ikkinchi velosipedchiga yetib oldi. Ikkinchi velosipedchining tezligini toping.

944. Kater oqim bo'ylab harakat qilib, 5 soatda 156,5 km yo'l bosdi. Agar katerning turg'un suvdagi tezligi 28,2 km/soat bo'lsa, daryo oqimning tezligini toping.



### Qiziqarli matematikaga oid masalalar

Berilgan raqamlarning o'rnini o'zgartirmay, arifmetik amallar va qavslarni shunday qo'yingki, natijada 1 hosil bo'lsin. Agar zarur bo'lsa, yonma-yon turgan ikki raqamni bitta ikki xonali son deb olishingiz ham mumkin.

$$\begin{aligned}
 1\ 2\ 3 &= 1 \\
 1\ 2\ 3\ 4 &= 1 \\
 1\ 2\ 3\ 4\ 5 &= 1 \\
 1\ 2\ 3\ 4\ 5\ 6 &= 1 \\
 1\ 2\ 3\ 4\ 5\ 6\ 7 &= 1 \\
 1\ 2\ 3\ 4\ 5\ 6\ 7\ 8 &= 1 \\
 1\ 2\ 3\ 4\ 5\ 6\ 7\ 8\ 9 &= 1
 \end{aligned}$$

## Bilimingizni sinab ko'ring!



Bu bob materiallarini o'rganib chiqib, quyidagi masalalarni yecha olishingiz shart! Nazorat ishi oldidan o'zingizni sinab ko'ring!

### 10- nazorat ishi namunasi

- Hisoblang:  
 a)  $4,35 \cdot 18$ ;      b)  $6,25 \cdot 108$ ;      d)  $126,385 \cdot 10$ ;  
 e)  $53,3 : 26$ ;      f)  $6 : 24$ ;      g)  $126,385 : 100$ .
- Tenglamani yeching:  $7y + 2,6 = 27,8$ .
- Ifodaning qiymatini toping:  $90 - 16,2 : 9 + 0,08$ .
- Avtomobilga 8 ta bir xil quti va har birining massasi 0,28 t bo'lgan 8 ta yashik ortildi. Agar butun yukning massasi 2,4 t bo'lsa, bitta qutining massasini toping.
- Birinchi ko'paytuvchida vergul 2 xona o'ngga, ikkinchi ko'paytuvchida 4 xona chapga surilsa, ko'paytma qanday o'zgaradi?

### Qiziqarli matematikaga oid masalalar



#### Sehrli kvadratlar

Rivoyat qilishlaricha, birinchi sehrli kvadrat bundan 7-8 ming yil avval Xitoyda tuzilgan. Bu kvadrat toshbaqa kosasiga yozilgan bo'lib, toshga aylangan toshbaqa ancha asrlardan keyin topib olingan (a- rasm). Kvadrat 9 ta katakdan iborat bo'lib, unda 1 dan 9 gacha bo'lgan raqamlar yozib qo'yilgan (b- rasm).

Ikkinchi sehrli kvadrat bundan ming yil avval Hindistonda tuzilgan. Uning 16 ta katagi bo'lib, unga 1 dan 16 gacha bo'lgan sonlar yozilgan (d- rasm).

Bu kvadratlarining har bir qatori, ustuni va diagonalida turgan sonlarni alohida-alohida qo'shib chiqing va ularning sehrli nimada ekanligini aniqlang:

a)

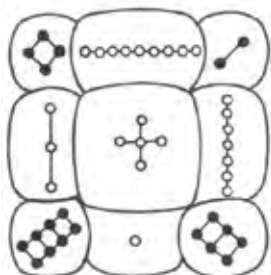

b)

4	9	2
3	5	7
8	1	6

d)

1	14	15	4
12	7	6	9
8	11	10	5
13	2	3	16

42- §.

**O'NLI KASRLARNI KO'PAYTIRISH**

*1- misol.* To'g'ri to'rtburchak tomonlari 3,6 sm va 5,2 sm. Uning yuzini toping.

*Yechish:* Bu masalani natural sonlarni ko'paytirish qoidasidan foydalanib yechamiz. Buning uchun berilganlarni millimetrdagi ifodalab olamiz: 3,6 sm = 36 mm va 5,2 sm = 52 mm. Endi to'g'ri to'rtburchak tomonlari natural sonlarda ifodalandi. Shuning uchun to'g'ri to'rtburchak yuzi bu sonlar ko'paytmasidan iborat bo'ladi:

$$36 \cdot 52 = 1872 \text{ (mm}^2\text{)}.$$

Hosil bo'lgan yuz kattaligini kvadrat santimetrda ifodalaymiz:

$$1 \text{ sm}^2 = 100 \text{ mm}^2 \text{ bo'lgani uchun } 1 \text{ mm}^2 = \frac{1}{100} \text{ sm}^2 \text{ bo'ladi.}$$

$$\text{Demak, } 1872 \text{ mm}^2 = \frac{1872}{100} \text{ sm}^2 = 18\frac{72}{100} \text{ sm}^2 = 18,72 \text{ sm}^2.$$

*Javob:* To'g'ri to'rtburchakning yuzi 18,72 sm<sup>2</sup> ga teng.

Aynan shu natijani, quyidagi o'nli kasrlarni ko'paytirish qoidasidan foydalanib ham qulayroq usulda hosil qilish mumkin:



**Ikki o'nli kasrni bir-biriga ko'paytirish uchun**

- vergullarga e'tibor bermasdan ular ko'paytiriladi;
- hosil bo'lgan ko'paytmaning o'ng tomonidan, shu ikkala kasrda birgalikda verguldan keyin nechta raqam bo'lsa, shuncha raqam vergul bilan ajratiladi.

*2- misol.* Bu qoidaga ko'ra 3,6 ni 5,2 ga ko'paytiraylik.

*Tushuntirish.* Vergullarga e'tibor bermay, 36 va 52 sonlarni ko'paytiramiz:

$$\begin{array}{r} \phantom{+} 3,6 \\ \times 5,2 \\ \hline \phantom{+} 72 \\ + 180 \\ \hline 18,72 \end{array}$$

36 · 52 = 1872 ni hosil qilamiz.

Har ikki ko'paytuvchida verguldan keyin bittadan, jami 2 ta raqam bor.

Shuning uchun 1872 ko'paytmaning o'ng tomonidan 2 ta raqamni vergul bilan ajratamiz. Natijada 18,72 ni hosil

qilamiz.

Ko'rib turganingizdek, har ikkala holda ham bir xil natijaga keldik.

*Eslatma.* Ko'paytirishni «ustun» shaklida bajarishda qo'shishdagidek vergul tagiga vergul yozilishi shart emas.

*3- misol.* 13,12 · 1,8 ko'paytmani topaylik.

$$\begin{array}{r} \phantom{+} 13,12 \\ \times 1,8 \\ \hline \phantom{+} 10496 \\ + 1312 \\ \hline 23,616 \end{array}$$

*Tushuntirish.* Ko'paytuvchilarda vergullardan keyin jami 3 ta raqam bor.

Shuning uchun ko'paytmada ham 3 ta raqamni vergul bilan ajratamiz.

Ba'zi hollarda ko'paytmaning raqamlarini vergul bilan ajratishda raqamlar yetarli bo'lmasligi mumkin. Bu hollarda ko'paytmaning chap tomoniga keragicha nollar yoziladi.

4- misol. 0,034 va 2,12 sonlarini ko'paytiraylik.

*Tushuntirish.*

$$\begin{array}{r}
 \times 0,034 \\
 \hline
 2,12 \\
 \hline
 68 \\
 + 34 \\
 \hline
 68 \\
 \hline
 0,07208
 \end{array}$$

34 va 212 sonlarining ko'paytmasi 7208 ga teng.

Ko'paytuvchilarda verguldan keyin jami

5 ta raqam bor. Ko'paytmada esa 4 ta raqam bor.

5 ta raqamni vergul bilan ajratish uchun uning chap tomoniga yana bitta 0 yozamiz va vergulni qo'yamiz. Albatta, bu holda bo'linmaning butun qismi 0 ga teng bo'ladi. Natijada 0,07208 ni hosil qilamiz.

O'nli kasrlarda ham oldin o'rganilgan ko'paytirish qonunlari o'rinli bo'ladi.

O'rin almashtirish qonuni:

$$a \cdot b = b \cdot a$$

Guruhlash qonuni:

$$(a \cdot b) \cdot c = a \cdot (b \cdot c)$$

Taqsimot qonuni:

$$(a+b) \cdot c = a \cdot c + b \cdot c$$

Ko'paytirish qonunlari ba'zida hisoblashlarni ancha osonlashtiradi. Buni quyidagi misollardan ham ko'rish mumkin:

5- misol. 1)  $(0,25 \cdot 7,23) \cdot 4 = (7,23 \cdot 0,25) \cdot 4 = 7,23 \cdot (0,25 \cdot 4) = 7,23 \cdot 1 = 7,23$ ;  
 2)  $8,2 \cdot 3,7 + 1,3 \cdot 8,2 = 8,2 \cdot (3,7 + 1,3) = 8,2 \cdot 5 = 41$

### Savollarga javob bering!



- O'nli kasrlarni ko'paytirish qoidasini ayting va uni misollarda tushuntirib bering.
- O'nli kasrlarni vergullarga e'tibor bermasdan ko'paytirganda, hosil bo'lgan ko'paytmadagi vergul qanday qo'yiladi?
- O'nli kasrlarni vergullarga e'tibor bermasdan ko'paytirganda, hosil bo'lgan ko'paytmada raqamlarni vergul bilan ajratishda yetarlicha raqamlar bo'lmasa nima qilinadi?
- O'nli kasrlar uchun ham oldin o'rganilgan ko'paytirish qonunlari o'rinli bo'ladimi?

### Sinfda bajariladigan mashqlar



945. Yig'indini oldin ko'paytmaga keltirib hisoblang:

a)  $4,3 + 4,3 + 4,3 + 4,3 + 4,3$ ;    b)  $1,25 + 1,25 + 1,25 + 1,25 + 1,25 + 1,25$ .

946. Hisoblang:

a)  $0,4 \cdot 0,6$ ;

b)  $0,12 \cdot 0,5$ ;

d)  $1,4 \cdot 0,2$ ;

e)  $1,5 \cdot 0,8$ ;

f)  $2,4 \cdot 0,3$ ;

g)  $5,2 \cdot 0,4$ ;

h)  $0,4 \cdot 12,6$ ;

i)  $0,3 \cdot 1,6$ ;

j)  $0,8 \cdot 0,12$ .

947. Quyidagi sonlar ko'paytmasida verguldan keyin nechta raqam bo'ladi?

a)  $12,42 \cdot 0,621$ ;

b)  $0,124 \cdot 45,5$ ;

d)  $21,467 \cdot 6,002$ ;

e)  $0,005 \cdot 1,8$ ;

f)  $1,412 \cdot 0,033$ ;

g)  $52 \cdot 0,403$ ;

h)  $0,024 \cdot 12$ ;

i)  $1,03 \cdot 1,68$ ;

j)  $1,8888 \cdot 0,10002$ .

**948.** Agar  $89 \cdot 73 = 6497$  ekanligi ma'lum bo'lsa, quyidagi ko'paytmani hisoblang:

- a)  $89 \cdot 7,3$ ;                      b)  $0,89 \cdot 7,3$ ;                      d)  $8,9 \cdot 73$ ;  
 e)  $8,9 \cdot 0,73$ ;                      f)  $8,9 \cdot 0,073$ ;                      g)  $8,9 \cdot 0,0073$ ;  
 h)  $0,89 \cdot 0,73$ ;                      i)  $0,89 \cdot 73$ ;                      j)  $89 \cdot 0,073$ .

**949.** Ko'paytirishni bajaring:

- a)  $1,2 \cdot 1,6$ ;                      b)  $0,21 \cdot 0,25$ ;                      d)  $41,2 \cdot 0,2$ ;  
 e)  $0,04 \cdot 0,003$ ;                      f)  $3,2 \cdot 2,4$ ;                      g)  $0,99 \cdot 0,02$ ;  
 h)  $0,8 \cdot 0,12$ ;                      i)  $15,2 \cdot 0,3$ ;                      j)  $1,4 \cdot 1,01$ .

**950.** Ko'paytirishni bajaring:

- a)  $6,25 \cdot 0,6$ ;                      b)  $0,75 \cdot 1,2$ ;                      d)  $0,412 \cdot 0,2$ ;  
 e)  $0,04 \cdot 0,003$ ;                      f)  $0,32 \cdot 0,04$ ;                      g)  $0,9 \cdot 0,02$ ;  
 h)  $0,8 \cdot 0,012$ ;                      i)  $15,2 \cdot 0,003$ ;                      j)  $1,4 \cdot 0,012$ .

**951.** Hisoblang:

- a)  $0,6^2$ ;                      b)  $0,3^2$ ;                      d)  $1,2^2$ ;                      e)  $0,7^2$ ;  
 g)  $0,6^3$ ;                      h)  $0,1^3$ ;                      i)  $1,1^3$ ;                      j)  $1,2^3$ .

**952.** Ko'paytirishni bajaring:

- a)  $0,123 \cdot 1,6$ ;                      b)  $0,21 \cdot 0,25$ ;                      d)  $21,25 \cdot 2,21$ ;  
 e)  $0,14 \cdot 0,023$ ;                      f)  $1,26 \cdot 2,41$ ;                      g)  $2,99 \cdot 2,02$ ;  
 h)  $7,908 \cdot 0,4$ ;                      i)  $0,752 \cdot 0,3$ ;                      j)  $1,7 \cdot 1,601$ .



**953.** Qulay usul bilan hisoblang: ( $0,5 \cdot 2 = 1$ ;  $0,25 \cdot 4 = 1$ ;  $0,125 \cdot 8 = 1$ ).

- a)  $0,5 \cdot 5,38 \cdot 2$ ;                      b)  $0,25 \cdot 12,63 \cdot 4$ ;                      d)  $0,125 \cdot 0,823 \cdot 8$ ;  
 e)  $5 \cdot 57,2 \cdot 0,2$ ;                      f)  $2,5 \cdot 0,23 \cdot 4$ ;                      g)  $1,25 \cdot 17,2 \cdot 8$ .

**954.** Qulay usul bilan hisoblang:

- a)  $1,2 \cdot 6,7 + 3,3 \cdot 1,2$ ;                      b)  $21,3 \cdot 4,8 + 5,2 \cdot 21,3$ ;                      d)  $3,2 \cdot 4,4 + 2,8 \cdot 4,4$ ;  
 e)  $67,2 \cdot 1,4 + 8,6 \cdot 67,2$ ;                      f)  $8,9 \cdot 3,7 + 6,3 \cdot 8,9$ ;                      g)  $0,2 \cdot 9,3 + 7,8 \cdot 0,2$ ;

**955.** a) 5,6; 0,854; 200; 5,8 sonlarini 3,6 marta orttiring;

b) 3,06; 12,5; 23,01; 3,904 sonlarni esa 2,8 marta orttiring.

**956.** To'g'ri to'rtburchak tomonlari: a) 3,5 sm va 4 sm; b) 4,3 sm va 4 dm;

d) 8 m va 2,66 m; e) 7,2 sm va 12,9 sm bo'lsa, uning yuzini toping.

**957.** 1 kg shakar narxi 4200 so'm.

Tarozida tortilgan shakar uchun necha so'm to'langan?



**958.** Xona polining bo'yi 5,75 m; eni 3,92 m. Polning yuzi nimaga teng? Javobni kvadrat metrning o'ndan birigacha yaxlitlang.

**959.** Amallarni bajaring:

- a)  $(7 - 4,996) \cdot 20,5 - 17,993$ ;                      b)  $0,18 \cdot (8,5 + 163,48) - 10,63$ ;  
 d)  $67,45 - 7,45 \cdot (3,8 + 4,2)$ ;                      e)  $28,6 + 11,4 \cdot (6,595 + 3,405)$ .



- 960.** 1 kg konfet 5800 so'm turadi. a) 2,3 kg; b) 1,5 kg; d) 0,8 kg; e) 0,2 kg konfet qancha turadi?
- 961.** 1 sm<sup>3</sup> temirning massasi 7,9 g. Hajmi a) 13,41sm<sup>3</sup>; b) 0,75 sm<sup>3</sup> bo'lgan temir parchasining massasini toping.
- 962.** Amallarni bajaring:  
 a)  $20,4 \cdot 6,5 - 3,8 \cdot (7,16 - 3,615) + 41,9$ ;  
 b)  $(0,547 + 4,333) \cdot 0,305 - 0,205 - 70 \cdot 0,005$ ;  
 d)  $29,48 - 18,48 \cdot (10 - 9,35) + 0,75$ ;  
 e)  $100,1 - 10,1 \cdot (0,038 + 0,162) \cdot 0,69$ .
- 963.** Agar  $a = 11,25$ ,  $b = 12,25$  bo'lsa,  $10,34a - 9,34b$  ifodaning qiymatini toping.
- 964.** Qulay usulda hisoblang:  
 a)  $2,5 \cdot 1,03 \cdot 4$ ;      b)  $0,5 \cdot 79,6 \cdot 2$ ;      d)  $0,25 \cdot 0,5 \cdot 2 \cdot 4$ ;  
 e)  $0,2 \cdot 7,09 \cdot 5$ ;      f)  $2,5 \cdot 23,8 \cdot 4$ ;      g)  $1,25 \cdot 0,45 \cdot 8$ .
- 965.** Amallarni bajaring:  
 a)  $2,5 \cdot 1,035 \cdot 4$ ;      b)  $7,5 \cdot 79,6 \cdot 0,4$ ;      d)  $3 \cdot 0,13 \cdot 0,5 \cdot 2$ ;      e)  $1,2 \cdot 7,09 \cdot 5 \cdot 10$ . 
- 
- 966.** Ko'paytirishning taqsimot qonunini qo'llab, ifodaning qiymatini toping:  
 a)  $64,52 \cdot 0,5039 + 35,48 \cdot 0,5039$ ;      b)  $6,305 \cdot 735,79 + 6,305 \cdot 264,21$ ;  
 d)  $204,56 \cdot 378,91 - 194,56 \cdot 378,91$ ;      e)  $0,87 \cdot 396,3 - 296,3 \cdot 0,87$ .
- 967.** 2,5 kg konfet va 2,3 kg pecheniy sotib olindi. Agar 1 kg pecheniy 1500 so'm, konfetning narxi pecheniynikidan 1100 so'm ortiq bo'lsa, bu xarid uchun qancha pul to'langan?
- 968.** Bo'yi 7,4 m, eni 5,85 m va balandligi 3,81 m bo'lgan xona devorlari yuzi yig'indisini toping. Xonaning hajmini toping. Natijalarni o'ndan birgacha yaxlitlang.
- 969.** Yer Quyosh atrofida sekundiga 29,8 km tezlikda aylanadi. Sayyoramiz: a) 4 sekundda; b) 5,8 sekundda; d) 23,4 sekundda; e) 1 minutda taxminan qancha yo'l bosadi?
- 970.** Qulay usulda hisoblang:  
 a)  $3,4 \cdot 2,6 + 1,3 \cdot 2,6 + 5,3 \cdot 0,7 + 5,3 \cdot 1,9$ ;  
 b)  $3,6 \cdot 3,8 + 1,6 \cdot 1,6 + 2,7 \cdot 4,6 + 0,9 \cdot 4,6$ ;  
 d)  $1,7 \cdot 2,3 - 1,7 \cdot 1,5 + 0,8 \cdot 2,2 - 0,8 \cdot 0,5$ ;  
 e)  $2,5 \cdot 3,5 - 1,6 \cdot 2,5 + 1,9 \cdot 0,7 + 0,8 \cdot 1,9$ .
- 971.** Agar  $8,9 \cdot 7,3 = 64,97$  ekanligi ma'lum bo'lsa, quyidagi ko'paytmani hisoblang:  
 a)  $89 \cdot 7,3$ ;      b)  $8,9 \cdot 73$ ;      d)  $8,9 \cdot 0,73$ ;  
 e)  $8,9 \cdot 0,73$ ;      f)  $8,9 \cdot 0,0073$ ;      g)  $89 \cdot 0,73$ ;  
 h)  $0,89 \cdot 0,73$ ;      i)  $890 \cdot 7,3$ ;      j)  $8,9 \cdot 730$ .



## Uyda bajariladigan mashqlar

972. Quyidagi sonlar ko'paytmasida verguldan keyin nechta raqam bo'ladi?

- a)  $23,43 \cdot 0,632$ ;      b)  $32,464 \cdot 6,03$ ;      d)  $0,006 \cdot 2,01$ ;  
 e)  $63 \cdot 0,0403$ ;      f)  $0,034 \cdot 23$ ;      g)  $2,111 \cdot 0,20003$ .

973. Ko'paytirishni bajaring:

- a)  $42,2 \cdot 0,2$ ;      b)  $22,6 \cdot 0,01$ ;      d)  $0,66 \cdot 0,02$ ;  
 e)  $0,23 \cdot 22$ ;      f)  $2,4 \cdot 2,02$ ;      g)  $0,33 \cdot 0,003$ .

974. Ko'paytirishni bajaring:

- a)  $28,16 \cdot 7,12$ ;      b)  $2,6 \cdot 0,801$ ;      d)  $2,99 \cdot 8,02$ ;  
 e)  $0,53 \cdot 21,002$ ;      f)  $2,4 \cdot 1,605$ ;      g)  $1,33 \cdot 9,32$ .

975. Agar  $29 \cdot 48 = 1392$  ekanligi ma'lum bo'lsa, quyidagi ko'paytmani hisoblang:

- a)  $0,29 \cdot 4,8$ ;      b)  $2,9 \cdot 48$ ;      d)  $2,9 \cdot 0,048$ ;  
 e)  $2,9 \cdot 0,0048$ ;      f)  $0,29 \cdot 48$ ;      g)  $29 \cdot 0,048$ .



976. To'g'ri to'rtburchak tomonlari: a) 5,3 sm va 6 sm; b) 3,4 sm va 2 dm; d) 6 m va 3,56 m; e) 8,5 sm va 24,7 sm bo'lsa, uning yuzini toping.

977. Mars sayyorasi Quyosh atrofida sekundiga 24,1 km tezlikda aylanadi. Mars: a) 5 sekundda; b) 3,2 sekundda; d) 12,8 sekundda; e) 1 minutda qancha yo'l bosadi?

978. Maktab dahlizining bo'yi 30,24 m, eni 6,12 m. Maktab dahlizining yuzini toping. Javobni yuzdan birgacha yaxlitlang.

979. Ifodaning qiymatini toping:

- a)  $308,6 \cdot 0,5 + 8,3 \cdot 4,5 - 3,5 \cdot (72 - 71,4)$ ;  
 b)  $0,625 \cdot 600 - 100 \cdot (6,1 - 3,16) + 0,92$ ;  
 d)  $125,61 - (3,67 - 2,38) \cdot (3,67 + 2,38) - 40,49$ ;  
 e)  $391,6 - 21,5 \cdot (0,38 + 0,25) \cdot 0,6 - 51,38 \cdot 3,45$ .



980. Ayol do'kondan 3,5 kg guruch va 0,8 kg konfet sotib oldi. Agar 1 kg guruch narxi 2800 so'm, 1 kg konfet narxi esa 3850 so'm bo'lsa, ayol xarid uchun necha so'm to'lagan?

981. Bir kub metr paxtaning massasi 0,08 t,  $1 \text{ m}^3$  tuproqning massasi 1,76 t.  $0,75 \text{ m}^3$  tuproq og'irimi yoki  $15,8 \text{ m}^3$  paxta?

982. Ifodaning qiymatini toping:

- a)  $2,945x + 1,549x - 20,9$ , bunda  $x = 22$ ;  
 b)  $6,002a - 2,25a + 8,11$ , bunda  $a = 16$ .

983. Amallarni bajaring:

- a)  $2076 + 456 \cdot 532 - 185\,060 : 487$ ;      b)  $4621 - 53\,856 : 396 + 119 \cdot 244$ ;  
 d)  $2103 \cdot 84 - 89\,364 + 190\,114 : 38$ ;      e)  $81\,108 : 27 + 91\,687 - 1305 \cdot 65$ .



- 984.** Xaridorda 172 000 so'm bor edi. U do'ppi va ro'molcha sotib oldi. Do'ppi uchun hamma pulining 0,1 qismini, ro'molcha uchun esa hamma pulining 0,01 qismini sarfladi. Xaridorda qancha pul qoldi?
- 985.** Agar  $2,9 \cdot 4,3 = 12,47$  ekanligi ma'lum bo'lsa, quyidagi ko'paytmani hisoblang:
- |                        |                         |                       |
|------------------------|-------------------------|-----------------------|
| a) $29 \cdot 4,3$ ;    | b) $2,9 \cdot 43$ ;     | d) $2,9 \cdot 0,43$ ; |
| e) $2,9 \cdot 0,43$ ;  | f) $2,9 \cdot 0,0043$ ; | g) $2,9 \cdot 430$ ;  |
| h) $0,29 \cdot 0,43$ ; | i) $290 \cdot 4,3$ ;    | j) $29 \cdot 0,43$ .  |
- 986.** Qulay usulda hisoblang:
- a)  $3,4 \cdot 1,6 + 2,3 \cdot 1,6 + 4,3 \cdot 0,7 + 4,3 \cdot 0,9$ ;
- b)  $5,6 \cdot 3,8 + 5,6 \cdot 1,6 + 2,7 \cdot 4,6 + 2,9 \cdot 4,6$ ;
- d)  $0,7 \cdot 2,3 - 0,7 \cdot 1,5 + 0,8 \cdot 1,2 - 0,8 \cdot 0,5$ ;
- e)  $6,5 \cdot 2,5 - 1,6 \cdot 6,5 + 0,9 \cdot 0,7 + 0,8 \cdot 0,9$ .
- 987.** Bo'yi 7,2 m, eni 5,1 m va balandligi 3,24 m bo'lgan xona devorlari yuzi yig'indisini toping. Xonaning hajmini toping. Natijalarni o'ndan birgacha yaxlitlang.
- 988.** Toshkent teleminorasida tomosha maydoni bo'lib, u 120 m balandlikda joylashgan. Agar teleminora balandligi tomosha maydoni balandligidan 3,125 marta uzun bo'lsa, minoraning balandligini toping.
- 989.** Bitta oddiy cho'g'lanma lampa bir yilda – 219 kilovatt-soat, energiyani tejovchi lyuminetsent lampa esa 43,8 kilovatt-soat elektr energiyani iste'mol qiladi. Agar oddiy lampa o'rniga energiyani tejovchi lampa ishlatilsa, oila bir yilda necha so'mni tejaydi? (1 kilovatt-soat elektr energiya narxi 144,3 so'm).
- 990.** Agar oila kuniga 4 kilovatt-soat elektr energiyani tejasa, a) bir oyda; b) bir yilda bu oila necha so'm tejaydi? (1 kilovatt-soat elektr energiya narxi 144,3 so'm).



### Qiziqarli matematikaga oid masalalar



Uchta bir xil olma to'rtta bir xil nokdan og'irroq. 4 ta olma og'irmi yoki 5 ta nok?

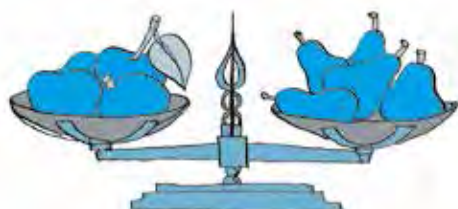
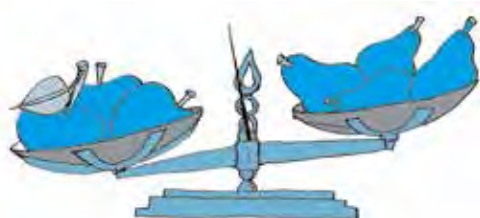

## 43- §.

## O'NLI KASRNI O'NLI KASRGA BO'LISH

**1- misol.** To'g'ri to'rtburchakning yuzi  $3,12 \text{ dm}^2$ , bo'yi esa  $2,6 \text{ dm}$ . To'g'ri to'rtburchak enining uzunligini toping.

**Yechish.** To'g'ri to'rtburchak yuzini topish uchun  $S = a \cdot b$  formuladan foydalanamiz. Shartga ko'ra,  $S = 3,12 \text{ dm}^2$ ,  $a = 2,6 \text{ dm}$  berilgan.  $b$  ni topishimiz kerak.

$3,12 \text{ dm}^2 = 312 \text{ sm}^2$  va  $2,6 \text{ dm} = 26 \text{ sm}$  bo'lgani uchun to'g'ri to'rtburchak eni  $b = S : a = 312 : 26$  yoki  $b = 12 \text{ sm} = 1,2 \text{ dm}$  ga teng bo'ladi.

Biz shunday  $1,2$  sonni topdikki, uni  $2,6$  ga ko'paytirsak:  $1,2 \cdot 2,6 = 3,12$  bo'ladi.

Demak, bu son  $3,12$  ni  $2,6$  ga bo'lganda hosil bo'ladigan bo'linmadan iborat bo'ladi va bu  $3,12 : 2,6 = 1,2$  tarzida yoziladi.

Bu natijani detsimetrlarni santimetrga o'tkazmasdan ham hosil qilish mumkin. Buning uchun bo'linuvchi  $3,12$  ni ham, bo'luvchi  $2,6$  ham  $10$  ga ko'paytirib (ya'ni ulardagi vergullarni bitta xona o'ngga surib)  $31,2$  ni  $26$  ga bo'lish kifoya.  $31,2$  o'nli kasrni natural son  $26$  ga bo'lib, yana oldingi natijani hosil qilamiz:  $31,2 : 26 = 1,2$ .



Sonni o'nli kasrga bo'lish uchun:

- bo'luvchida verguldan keyin nechta raqam bo'lsa, bo'linuvchida ham bo'luvchida ham vergul o'shancha xona o'ngga suriladi;
- so'ng bo'lish o'nli kasrni natural songa bo'lgan kabi amalga oshiriladi.

**2- misol.**  $19,376$  ni  $3,46$  ga bo'laylik.

Bo'luvchi  $3,46$  da verguldan keyin  $2$  ta raqam bor. Shuning uchun bo'linuvchi  $19,376$  da ham, bo'luvchi  $3,46$  da ham vergulni o'ngga  $2$  xonaga suramiz. Natijada  $1937,6$  va  $346$  sonlarini hosil qilamiz. O'nli kasrni natural songa bo'lish holiga keldik. Bo'lishni bajarib,  $1937,6 : 346 = 5,6$  ekanligini topamiz. Demak,  $19,376$  ning  $3,46$  ga bo'linmasi  $5,6$  ga teng bo'ladi:  $19,376 : 3,46 = 5,6$ .

**Javob:**  $5,6$ .

**3- misol.**  $4,3$  ni  $0,215$  ga bo'laylik.

Bu yerda bo'linuvchida ham, bo'luvchida ham vergulni  $3$  xona o'ngga surish kerak. Bo'linuvchida verguldan keyin bitta raqam bo'lgani uchun uning o'ng tomoniga ikkita nol yozamiz. Vergulni surgandan keyin  $4300$  va  $215$  sonlarini hosil qilamiz va bo'lishni bajaramiz.  $4300 : 215 = 20$  bo'lgani uchun  $4,3 : 0,215$  ham  $20$  ga teng bo'ladi.

**Javob:**  $20$ .

**4- misol.**  $5,248$  ni  $0,01$  ga bo'laylik.

Bo'linuvchi  $55,248$  da ham, bo'luvchi  $0,01$  da ham vergulni  $2$  xona o'ngga surib,  $524,8 : 1 = 524,8$  ni hosil qilamiz. Demak,  $5,248 : 0,01 = 524,8$ .

Bundan quyidagi qoidaga kelamiz.

**Javob:**  $524,8$ .



O'nli kasr hamda  $0,1$ ;  $0,01$ ;  $0,001$  va hokazo (bir nechta nollar va  $1$  dan iborat) sonlarning bo'linmasini topish uchun o'nli kasrdagi vergulni bu sonlarda birdan oldin nechta nol turgan bo'lsa, o'shancha xona o'ngga surish kifoya.

Agar nollar yetishmasa, oldin o'nli kasr oxiriga keragicha nollarni yozish kerak bo'ladi.

Masalan,  $39,12 : 0,0001 = 39,1200 : 0,0001 = 391200$ .

O'ni kasrni 0,1; 0,01; 0,001 va hokazo sonlarga bo'lish — uni mos ravishda 10, 100, 1000 va hokazo sonlarga ko'paytirish demakdir.

Shuningdek, o'ni kasrni 10, 100, 1000 va hokazo sonlarga bo'lish — uni mos ravishda 0,1; 0,01; 0,001 va hokazo sonlarga ko'paytirish demakdir.



### Savollarga javob bering!



- O'ni kasrlarni bo'lish qoidasini ayting va uni misollarda tushuntirib bering.
- O'ni kasrlarni vergullarga e'tibor bermasdan bo'lishganda, hosil bo'lgan bo'linmadagi vergul qanday qo'yiladi?
- Kasr sonni 0,1; 0,01; 0,001 va hokazo sonlarga bo'lish qanday amalga oshiriladi?
- Kasr sonni 10, 100, 1000 va hokazo sonlarga bo'lish qanday amalga oshiriladi?

### Sinfda bajariladigan mashqlar



**991.** Hisoblang:

- |                |                |              |                 |
|----------------|----------------|--------------|-----------------|
| a) $0,9 : 3$ ; | b) $7,5 : 3$ ; | d) $1 : 2$ ; | e) $1,8 : 6$ ;  |
| f) $4,5 : 3$ ; | g) $2,4 : 3$ ; | h) $3 : 2$ ; | i) $0,54 : 2$ . |

**992.** Tushirib qoldirilgan sonlarni ayting:

- |                            |                           |                            |
|----------------------------|---------------------------|----------------------------|
| a) $3 \cdot \dots = 3,6$ ; | b) $2 \cdot \dots = 5$ ;  | d) $\dots \cdot 2 = 0,8$ ; |
| e) $10 \cdot \dots = 3$ ;  | f) $0,3 : \dots = 0,03$ ; | g) $\dots : 0,3 = 3$ ;     |
| h) $\dots : 0,5 = 2$ ;     | i) $5 : \dots = 2$ ;      | j) $0,9 : \dots = 0,09$ .  |

**993.** Bo'lishni bajaring:

- |                   |                    |                    |
|-------------------|--------------------|--------------------|
| a) $17,4 : 0,6$ ; | b) $30,6 : 0,9$ ;  | d) $17,28 : 7,2$ ; |
| e) $4,95 : 1,5$ ; | f) $0,343 : 0,7$ ; | g) $1,624 : 5,6$ ; |
| h) $3,36 : 1,5$ ; | i) $8,46 : 1,2$ ;  | j) $10,01 : 9,1$ . |

**994.** Bo'lishni bajaring:

- |                     |                    |                      |
|---------------------|--------------------|----------------------|
| a) $512 : 0,16$ ;   | b) $198 : 0,036$ ; | d) $12,25 : 0,005$ ; |
| e) $15,3 : 0,015$ ; | f) $81,2 : 0,35$ ; | g) $1050 : 4,2$ .    |

**995.** Bo'lishni bajaring:

- |                     |                    |                    |
|---------------------|--------------------|--------------------|
| a) $8,9 : 0,4$ ;    | b) $3,08 : 0,05$ ; | d) $77,7 : 0,37$ ; |
| e) $0,2106 : 3,9$ ; | f) $1,23 : 0,6$ ;  | g) $28,42 : 1,4$ ; |
| h) $11,1 : 0,04$ ;  | i) $0,04 : 2,5$ ;  | j) $3,534 : 0,5$ . |

**996.** Bo'lishni bajaring:

- |                    |                     |                   |
|--------------------|---------------------|-------------------|
| a) $12 : 0,3$ ;    | b) $6 : 0,6$ ;      | d) $15 : 0,1$ ;   |
| e) $48 : 0,8$ ;    | f) $0,35 : 0,007$ ; | g) $1,6 : 0,2$ ;  |
| h) $0,24 : 0,12$ ; | i) $0,3 : 0,3$ ;    | j) $0,15 : 0,5$ . |

**997.** Hisoblang. Natijani ko'paytirish orqali tekshiring:

- |                     |                    |                     |
|---------------------|--------------------|---------------------|
| a) $8,04 : 6,7$ ;   | b) $1,072 : 0,8$ ; | d) $0,945 : 1,8$ ;  |
| e) $70 : 5,6$ ;     | f) $14,23 : 0,1$ ; | g) $0,24 : 0,001$ ; |
| h) $12,24 : 0,12$ ; | i) $9,39 : 0,3$ ;  | j) $15,15 : 0,5$ .  |



- 998.** Abdurahmon qadamining uzunligi 0,45 m. U 54 m yo'l yurishi uchun necha qadam tashlashi kerak?
- 999.** Bo'lishni bajaring:  
 a)  $54,0204 : 4,2$ ; || b)  $0,45716 : 0,22$ ; || d)  $11,648 : 5,6$ ; || e)  $105,3535 : 3,5$ ;  
 f)  $1 : 0,8$ ; || g)  $3 : 0,75$ ; || h)  $10 : 2,5$ ; || i)  $1 : 12,5$ .
- 1000.** Agar: a)  $a = 2,3712$ ,  $b = 1,45$ ,  $d = 0,31$ ; b)  $a = 0,273$ ,  $b = 4,38$ ,  $d = 4,12$  bo'lsa,  $M = a : (b - d)$  formula bo'yicha  $M$  ning qiymatini toping.

**1001.** Amallarni bajaring:

a)  $(131,4 - 80,8) : 2,3 - 21,84$ ; || b)  $8,16 : (1,32 + 3,48) - 0,345$ .

- 1002.** Qimmatbaho toshlarni tortishda massa birligi – qirotd qo'llaniladi. Bir qirotd 0,2 grammga teng. Agar olmos 0,9 g bo'lsa, uning massasini qirotda ifodalang.

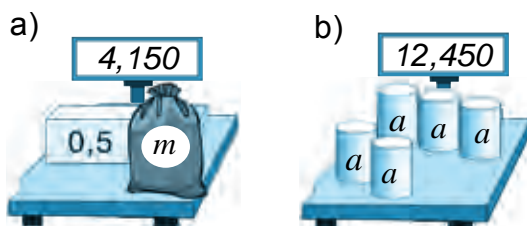

1- rasm

- 1003.** Mosh ekishda 0,24 ga yerga 0,03 t urug' sepiladi. 2 t urug'ni qanday maydonga sepish mumkin?



- 1004.** 1- rasmga ko'ra tenglama tuzing va uni yeching.

**1005.** Tenglamani yeching:

a)  $1000 - 0,708x = 999,57166$ ; || b)  $(x + 26,1) \cdot 2,3 = 70,84$ ;  
 d)  $(x - 1,2) : 0,604 = 21,14$ ; || e)  $(10,49 - a) : 4,02 = 0,805$ ;  
 f)  $8,2x - 4,4x = 38,38$ ; || g)  $9a - 8,67a = 0,6699$ .

- 1006.** Qalaydan ikkita buyum quyildi. Birinchi buyumga  $6,3 \text{ sm}^3$ , ikkinchisiga  $4,9 \text{ sm}^3$  qalay ketdi. Agar kichik buyumning massasi 22,05 g bo'lsa, katta buyumning massasi qancha?

- 1007.** Toshkentdan Samarqandgacha bo'lgan masofa 300 km. Bu masofani «Afrosiyob» tezyurar poyezdi 2 soat 30 minutda bosib o'tadi. «Afrosiyob» tezyurar poyezdining tezligini toping.



**1008.** Ifodalar qiymatini taqqoslang:

a)  $307,495 - 87,495 : (31,7 - 3,2)$  va  $29,8 \cdot 105$ ;  
 b)  $67,75 \cdot 3,81 + 32,25 \cdot 3,81$  va  $380 \cdot 1,976 - 380 \cdot 0,976$ .

**1009.** Xatolikni toping va to'g'ri tenglikni yozing:

a)  $2,58 : 1,2 = 258 : 12$ ; || b)  $9,12 : 0,3 = 9,12 : 3$ .



**1010.** Ifodaning qiymatini toping:

- a)  $12,444 : (7 - 2,92) + 1,03 \cdot (13,65 - 3)$ ;  
 b)  $0,56994 : (1 - 0,195) - 0,28623 : (1 - 0,594)$ ;  
 d)  $(3,4 : 17 + 1,7 : 34) \cdot 4,2 + 8,25 : 3$ ;  
 e)  $((4,1 - 2,5 + 1,07 - 0,08) \cdot 0,41 \cdot 5) : 0,41$ .

**1011.** Hajmi  $50 \text{ sm}^3$  bo'lgan alumin sharning massasi 135 g. Agar  $1 \text{ sm}^3$  aluminning massasi  $1 \text{ sm}^3$  temirning massasidan 5,2 g kam bo'lsa, shunday hajmdagi temir sharning massasi qancha bo'ladi?

**1012.** Qaysi holda arzon xarid amalga oshiriladi?



**1013.** Bo'lishni bajaring:

- a)  $37,4 : 0,1$ ; b)  $80,62 : 0,1$ ; d)  $1,981 : 0,1$ ; e)  $234,9 : 0,01$ ;  
 f)  $1,02 : 0,01$ ; g)  $15,164 : 0,01$ ; h)  $2,1306 : 0,001$ ; i)  $38,411 : 0,001$ .

**1014.** Bo'lishni bajaring:

- a)  $3,7 : 0,1$ ; b)  $6,2 : 0,1$ ; d)  $191 : 0,1$ ; e)  $24,9 : 0,01$ ;  
 f)  $1,2 : 0,01$ ; g)  $15 : 0,01$ ; h)  $2,1 : 0,001$ ; i)  $8,41 : 0,001$ .

**1015.** Tushirib qoldirilgan sonni yozib, bo'linmani ko'paytma ko'rinishiga keltiring va ko'paytmani hisoblang:

- a)  $5,1 : 0,1 = 5,1 \cdot \dots$ ; b)  $3,1 : 0,1 = 3,1 \cdot \dots$ ; d)  $1,2 : 0,01 = 1,2 \cdot \dots$ ;  
 e)  $6,1 : 0,01 = 6,1 \cdot \dots$ ; f)  $11,2 : 0,001 = 11,2 \cdot \dots$ ; g)  $21,9 : 0,001 = 21,9 \cdot \dots$ .

**1016.** Bitta oddiy cho'g'lanma lampa bir yilda – 219 kilovatt-soat, energiyani tejovchi lyuminetsent lampa esa – 43,8 kilovatt-soat elektr energiyani iste'mol qiladi. Lyuminetsent lampa oddiy lampadan necha marta tejamliroq?

**1017.** 1 litr suvni elektr choynakda qaynatish 14,4 so'mga, elektr plitkada qaynatish – 46,8 so'mga tushadi. Elektr choynakni ishlatish elektr plitkaga qaraganda necha marta arzon?

### Uyda bajariladigan mashqlar



**1018.** Bo'lishni bajaring:

- a)  $47,2 : 0,2$ ; b)  $25,92 : 7,2$ ; d)  $5,55 : 1,5$ ;  
 e)  $2,688 : 5,6$ ; f)  $2,85 : 1,5$ ; g)  $13,65 : 9,1$ .

**1019.** Bo'lishni bajaring:

- a)  $192 : 0,16$ ; b)  $684 : 0,036$ ; d)  $22,25 : 0,005$ ;  
 e)  $15,6 : 0,015$ ; f)  $45,5 : 0,35$ ; g)  $2142 : 4,2$ .

**1020.** Bo'lishni bajaring:

- a)  $2,7 : 0,4$ ;      b)  $92,5 : 0,37$ ;      d)  $0,2184 : 3,9$ ;  
 e)  $42,42 : 1,4$ ;      f)  $21,3 : 0,04$ ;      g)  $0,536 : 0,5$ .



**1021.** Bo'lishni bajaring:

- a)  $34 : 1,7$ ;      b)  $19 : 0,01$ ;      d)  $42 : 0,6$ ;  
 e)  $6,8 : 0,02$ ;      f)  $0,48 : 0,06$ ;      g)  $0,75 : 0,5$ .

**1022.** Bo'lishni bajaring:

- a)  $54,0204 : 4,2$ ;      b)  $0,45716 : 0,22$ ;      d)  $105,3535 : 3,5$ ;  
 e)  $1 : 0,8$ ;      f)  $10 : 2,5$ ;      g)  $3 : 6,25$ .

**1023.** Bo'linmani toping:

- a)  $133,111 : 2,2$ ;      b)  $2639,58 : 8,7$ ;      d)  $46,98 : 1,16$ ;  
 e)  $421 : 1,6$ ;      f)  $48 : 0,75$ ;      g)  $9 : 0,45$ .



**1024.** G'ildirak aylanasining uzunligi 1,5 m. G'ildirak 20,5 marta aylanganda qancha masofani bosib o'tadi? G'ildirak 231 m masofani bosib o'tganda necha marta aylanadi?

**1025.** Dehqon 0,35 ga yerga 0,021 t urug' sepdi. 0,3 t shunday urug'ni qancha maydonga sepish mumkin?

**1026.** Tenglamani yeching:

- a)  $1,936 : x = 3,2$ ;      b)  $1,48a = 30,34$ ;      d)  $b : 8,04 = 5,05$ ;      e)  $30,3 : k = 30$ .



**1027.** Qurilishga 24 000 dona g'isht keltirildi. Singan g'ishtlar hamma g'ishtning 0,015 qismini tashkil qiladi. Qurilishga nechta butun g'isht keltirilgan?

**1028.** Hisoblang. Natijani ko'paytirish orqali tekshiring:

- a)  $7,65 : 1,7$ ;      b)  $3,848 : 0,8$ ;      d)  $0,414 : 1,8$ ;      e)  $84 : 5,6$ ;  
 f)  $44,56 : 0,1$ ;      g)  $0,31 : 0,001$ ;      h)  $60,24 : 0,12$ ;      i)  $15,39 : 0,3$ .

**1029.** Amallarni bajaring:

- a)  $0,21 : 5 + 3,17 : 8 - 2,22 : 16 + 3,7 : 4$ ;  
 b)  $(15,94 + 17,54) : (10,96 + 16,04) \cdot 3,72 - 1,901$ .

**1030.** Hazrati Imom masjidi minorasining balandligi 59 m bo'lib, u Minor masjidi minorasidan 1,18 marta baland. Minor masjidi minorasining balandligini toping.



## 44- §.

## O'RTA ARIFMETIK

Kundalik turmushda siz gazeta va jurnallardan, radio va televideniya hamda internet sahifalaridan o'rtacha hosildorlik, o'rtacha oylik, o'rtacha kunlik harorat, aholining o'rtacha yoshi, narxlarning o'rtacha o'sishi, o'rtacha mehnat unumdorligi, o'rtacha o'zlashtirish kabi o'rtacha miqdorlar haqida o'qigan yoki eshitgan bo'lsangiz kerak. Bu qanday miqdorlar, ular qanday topiladi va ularni bilish nima uchun kerak? Quyida shu haqda to'xtalamiz.

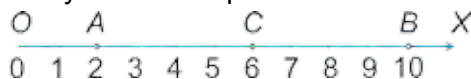

1- rasm

1-rasmdagi sonlar nurida  $A(2)$  va  $B(10)$  nuqtalar berilgan. Bu nuqtalarning o'rtasida joylashgan  $C$  nuqtaning koordinatasi 6 ga teng bo'lib, u  $A$  va  $B$  nuqtalar koordinatalari orqali quyidagicha topiladi:  $\frac{2+10}{2} = 6$ . Bu yerda 6 soni 2 va 10 sonlarning o'rta arifmetigi deb ataladi.

Bir nechta sonlarning *o'rta arifmetigi* deb, bu sonlar yig'indisini ularning soniga bo'lish natijasiga aytiladi.

Uchta  $a$ ,  $b$  va  $c$  *sonlarning o'rta arifmetigini* topish uchun bu sonlar yig'indisi  $(a + b + c)$  ni, ularning soni 3 ga bo'lish kifoya:

$$\boxed{\text{\textit{a, b va c sonlarning o'rta arifmetigi}}} = \frac{(a + b + c)}{3} \quad \begin{array}{l} \leftarrow \text{\textit{sonlar yig'indisi}} \\ \leftarrow \text{\textit{ularning soni}} \end{array}$$

**1-misol.** Alisher baliq oviga chiqdi. U birinchi soatda 6 ta, ikkinchi soatda 11 ta va uchinchi soatda 10 ta baliq ovladi. Alisher bir soatda o'rtacha nechtadan baliq ovlagan?

**Yechish:** Alisher 3 soat davomida hammasi bo'lib  $6 + 11 + 10 = 27$  ta baliq ovlagan. U bir soatda o'rtacha  $27 : 3$ , ya'ni 9 tadan baliq ovlagan.

**Javob:** Alisher bir soatda o'rtacha 9 tadan baliq ovlagan.

Bir nechta sonlarning o'rta arifmetigi bu sonlarning eng kichigidan katta va eng kattasidan kichik bo'ladi. Buning to'g'riligini yuqoridagi 1-misolda tekshirib ko'ring.

O'rtacha tezlik deb bosib o'tilgan yo'lni sarflangan vaqtga nisbatiga aytiladi.

**2- misol.** Poyezd masofani 2 soat davomida 85 km/soat tezlik bilan va 3 soat davomida 80 km/soat tezlik bilan bosib o'tdi. Poyezdning o'rtacha tezligini toping.

**Yechish:** Poyezd bosib o'tgan yo'lni hisoblaymiz:

$$85 \cdot 2 + 80 \cdot 3 = 170 + 240 = 410 \text{ (km)}.$$

Bu masofani poyezd  $2 + 3 = 5$  soatda bosib o'tdi. Poyezdning o'rtacha tezligini topish uchun bosib o'tilgan yo'lni sarflangan vaqtga bo'lamiz:  $410 : 5 = 82$  (km/soat).

**Javob:** Poyezdning o'rtacha tezligi – 82 km/soat.

Bu natijani poyezdning har bir soatdagi tezliklari o'rta arifmetigini hisoblash orqali ham topsa bo'lar edi:  $(85 + 85 + 80 + 80 + 80) : 5 = 82$  (km/soat).

**Savollarga javob bering!**



1. Bir nechta sonlarning o'rta arifmetigi deb nimaga aytiladi?
2. O'rtacha tezlik qanday topiladi?

## Sinfda bajariladigan mashqlar



- 1031.** Sonlarning o'rtta arifmetigini hisoblang:  
a) 2,18; 8,03;                      b) 0,49; 2,82; 6,41;    d) 16,03; 8,41; 3,07; 0,1;
- 1032.** Poyezd birinchi soatda 55 km, ikkinchi soatda 75 km yurdi. Poyezdning shu ikki soatdagi o'rtacha tezligini toping.
- 1033.** Sayohatchi 4 soat 2,7 m/s tezlik bilan, so'ng esa 5 soat 1,8 m/s tezlik bilan yurdi. Sayohatchining o'rtacha tezligi qancha?
- 1034.** a) 8 va 10; b) 12 va 16; d) 4 va 8 sonlarining o'rtta arifmetigini toping. Bu sonlarni va ularning o'rtta arifmetigini sonlar nurida tasvirlang. Nima sababdan «sonlarning o'rtta arifmetigi» atamasida «o'rtta» so'zi ishlatilishi haqida o'ylab ko'ring.
- 1035.** Ustaxonada 3 ta ishchi ishlaydi. Bir soatda birinchi ishchi 24 ta, ikkinchi ishchi 20 ta, uchinchi ishchi esa 28 ta detalga ishlov beradi. Ustaxona ishchilari mehnatining o'rtacha unumdorligi qancha?
- 1036.** «Nasaf» tezyurar poyezdi Toshkentdan Samarqandgacha 3,2 soat 95 km/soat tezlik bilan, Samarqanddan Qarshigacha esa 2,1 soat 90 km/soat tezlik bilan yurdi. «Nasaf» poyezdining o'rtacha tezligini aniqlang.



- 1037.** Sonlarning o'rtta arifmetigini toping:  
a) 80,6; 71,3;    ||    b) 0,4; 0,8; 0,9;    ||    d) 2,11; 2,12; 2,19; 2,48;
- 1038.**  $a$  va 8,9 sonlarining o'rtta arifmetigi – 9,5 ga teng.  $a$  sonini toping.
- 1039.** Amaliy ish. Tarozida 100 g no'xat tortib oling. Undagi no'xat donalari sonini sanang. Bir dona no'xatning o'rtacha massasini toping.
- 1040.** 7 ta hakam »Quvnoqlar va zukkolar« musobaqasida qatnashgan guruhga, mos ravishda, quyidagi baholarni qo'ydi: 5; 4; 4; 5; 3; 4; 3. Guruhning o'rtacha bahosini toping.
- 1041.** Bir hafta davomida havo harorati quyidagicha bo'ldi: 18<sup>0</sup>C; 20<sup>0</sup>C; 21<sup>0</sup>C; 18<sup>0</sup>C; 19<sup>0</sup>C; 22<sup>0</sup>C; 24<sup>0</sup>C. Bu hafta davomidagi o'rtacha harorat qanchani tashkil qilgan?
- 1042.** 14,12; 14,747; 14,96 va 14,58 sonlarining o'rtta arifmetigini toping va uni o'ndan birgacha yaxlitlang.



- 1043.** Xo'jalik besh yil davomida har yilda o'rtacha 76,3 t qand lavlagi yetishtirgan. Shu besh yil davomida xo'jalikda hammasi bo'lib necha tonna qand lavlagi yetishtirilgan?
- 1044.** Samolyot Toshkentdan Andijonga 45 minut 800 km/soat tezlik bilan, Andijondan Toshkentga esa 1 soat 15 minut 750 km/soat tezlik bilan uchdi. Samolyotning o'rtacha tezligini toping.
- 1045.** Bir tomchi suvning massasini aniqlash uchun oldin stakanga 100 tomchi suv tomizildi va uning massasi tarozida tortilib 62 g ekanligi ahiqlandi. Agar bo'sh stakanning massasi 55 g bo'lsa, bir tomchi suvning massasi qancha?



- 1046.** Termometr bilan havo harorati sutka davomida o'lchanganda, u ertalab  $+18^{\circ}\text{C}$ , tushda  $+25^{\circ}\text{C}$ , kechqurun  $+21^{\circ}\text{C}$  va kechasi  $+10^{\circ}\text{C}$  ni ko'rsatdi. Sutkalik o'rtacha haroratni aniqlang.
- 1047.** Hadicha chorak davomida matematikadan quyidagi baholarni oldi: 5, 5, 4, 5, 4, 5, 5, 4. Uning chorak bo'yicha o'rtacha bahosini toping va uni birlar xonasigacha yaxlitlang.

### Uyda bajariladigan mashqlar



- 1048.** Sonlarning o'рта arifmetigini hisoblang:  
 a) 4,38; 6,05.      b) 0,39; 9,42; 3,41.      d) 6,07; 12,41; 2,011.  
 e) 1,02; 1,15; 1,3; 1,4.      f) 22,4; 36,7; 56,2.      g) 0,203; 0,324; 2,61.
- 1049.** O'nta qadamingizning uzunligini o'lchang va qadamingiz o'rtacha uzunligini toping.
- 1050.** Poyezd birinchi soatda 76 km, ikkinchi soatda 90 km, uchinchi soatda esa 80 km yurdi. Poyezdning shu uch soatdagi o'rtacha tezligi qancha?



- 1051.** Bir soatda birinchi ishchi 56 ta, ikkinchi ishchi esa undan 16 ta ko'p detalga ishlov beradi. Bu ishchilar mehnatining o'rtacha unumdorligi qancha?
- 1052.** Ikkita sonning o'rtacha arifmetigi 5,4. Ikkinchi son 7,8 bo'lsa, birinchi sonni toping.
- 1053.** Ikkita sonning o'rtacha arifmetigi 6,2. Birinchi son ikkinchi sondan 1,5 marta katta bo'lsa, bu sonlarni toping.
- 1054.** Amallarni bajaring:  
 $((4 : 0,128 + 14628,25) : 1,011 - 0,00008 + 6,84) : 12,5$ .



- 1055.** Avtomobil katta ko'chadan 2,1 soat 90 km/soat tezlik bilan, so'ng esa 3,8 soat tosh ko'chadan 40 km/soat tezlik bilan yurdi. Avtomobilning o'rtacha tezligini toping.
- 1056.** To'rtta sonning o'rtacha arifmetigi 8,9 ga teng. Boshqa 6 ta sonning o'rtacha arifmetigi esa 13,8 ga teng. Bu o'nta sonning o'rtacha arifmetigi qancha?
- 1057.** Quyidagi jadvalda oilada ishlatiladigan turli elektr asboblari va ulardan bir sutkada foydalanish ko'rsatkichlari ketirilgan. Bu ma'lumotlardan foydalanib jadvalni to'ldiring. Shunga o'xshash jadvalni o'z oilangiz misolida ham tuzing va xulosalar qiling.

№	Nomi	Soni (dona)	Jami quvvati, (kilovatt)	Sutkada ishlatilishi (soat)	Sutkada sarflangan elektr energiyasi (kilovatt·soat)
1.	Elektr lampochkasi	6	0,36	14	
2.	Sovutkich	1	0,03	24	
3.	Televizor	1	0,085	2	
4.	Kompyuter	1	0,25	3	
5.	Dazmol	1	2,3	0,1	
				Jami	

## 45.1. Oilada tejamkorlik va matematika

Elektr chirog'i yonganda yoki elektr asboblari ishlatilganda elektr energiyasi sarflanadi. Elektr energiyasi elektr stansiyalarda ishlab chiqariladi. Uni ishlab chiqarishda suv, gaz va neft mahsulotlaridan foydalaniladi.

Elektr energiyasidan tejamli foydalanish kerak.

Elektr energiyasi kilovatt-soat deb nomlangan o'lchov birligida o'lchanadi. Sarflangan 1 kilovatt-soat elektr energiyasi uchun aholi 144,3 so'm haq to'laydi (2014-yil oktabr oyida).

Xonadonda sarflanayotgan elektr energiyasi maxsus hisoblagich yordamida o'lchab boriladi. Xonadon egasi hisoblagich ko'rsatkichiga qarab har oyda to'lovni amalga oshiradi. Aytaylik, oktabr oyi boshida hisoblagich 34538 ni, oy oxirida 34658 ni ko'rsatgan bo'lsin. Demak, sentabr oyi mobaynida xonadon  $34658 - 34538 = 120$  (kilovatt-soat) elektr energiyasi sarflagan. 1 kilovatt-soat elektr energiyasi 144,3 so'm turishini hisobga olsak, xonadon egasi iste'mol qilingan elektr energiyasi uchun  $120 \cdot 144,3 = 17\ 316$  (so'm) pul to'lashi lozim bo'ladi.



- 1058.** Dazmol 1 soat ishlatilganda 1 kilovatt-soat elektr energiyasi sarflanadi. Dazmol: a) 3 soat; b) 4 soat ishlatilganda necha so'mlik elektr energiyasi sarflanadi?
- 1059.** Elektr chirog'i 10 soat yonib tursa, 1 kilovatt-soat elektr energiyasi sarflanadi. Kechasi yo'lak 10 soat davomida yoritiladi. Bir oy (30 kun) davomida yo'lakni yoritish uchun davlat tomonidan qancha mablag' sarflanadi?
- 1060.** Xonadonda bir oy davomida 50 soat keraksiz yonib qolgan: a) bitta; b) ikkita; d) uchta elektr chirog'i uchun necha so'm to'lash kerak bo'ladi?
- 1061.** Rasmda tasvirlangan hisoblagichning dastlabki (a- rasm) va oxirgi (b- rasm) ko'rsatkichlariga qarab, iste'mol qilingan elektr energiyasi uchun qancha pul to'lash lozimligini aniqlang:

a)



b)



- 1062.** Issiq suv hisoblagichining (kub metrda) dastlabki – 546 091 va oxirgi – 546 121 ko'rsatkichlariga qarab, iste'mol qilingan issiq suv uchun qancha pul to'lash lozimligini aniqlang. Iste'mol qilingan 1 kub metr issiq suv haqi 2706,76 so'mni tashkil qiladi (2014-yil oktabr oyida).

**1063.** Rasmda tasvirlangan gaz hisoblagichining (kub metrda) dastlabki (a-rasm) va oxirgi (b- rasm) ko'rsatkichlariga qarab, iste'mol qilingan gaz uchun qancha pul to'lash lozimligini aniqlang. Iste'mol qilingan 1 kub metr gaz haqi 181,62 so'mni tashkil qiladi (2014-yil oktabr oyida):



**1064.** Sovuq suv hisoblagichining (kub metrda) dastlabki – 120 674 va oxirgi – 120 723 ko'rsatkichlariga qarab, iste'mol qilingan sovuq suv uchun qancha pul to'lash lozimligini aniqlang. Iste'mol qilingan 1 kub metr sovuq suv haqi 310 so'mni tashkil qiladi (2014-yil oktabr oyida).

**1065.** Iqtisodchilar hisob-kitobiga ko'ra suv jo'mragi yaxshi yopilmasa, undan 1 sutkada 140 litr suv tomchilab oqib ketar ekan. Bir oy (30 kun) da bu sozlanmagan suv jo'mragidan qancha suv oqib isrof bo'ladi? Isrof qilingan suvga qancha haq to'lash kerak bo'ladi?



**Suv – hayot manbayi! Uni tejab ishlating!**

## 45.2. VII bobga doir masalalar yechish

- 1066.** Ovchilardan biri 30 ta quyvon otdi. Ikkinchisi birinchisidan 0,4 marta ko'p, uchinchi esa ikkinchisidan 10 ta kam quyvon otdi. Uchala ovchi qancha quyvon otgan?
- 1067.** Birinchi dala yuzi 189,5 ga, ikkinchisining yuzi undan 15 ga ortiq. Birinchi dalaning gektaridan 24 sr, ikkinchisining gektaridan 31 sr bug'doy olingan bo'lsa, ikkala daladan qancha bug'doy hosili olingan?
- 1068.** Men bir son o'yladim. Agar bu songa uning o'zini qo'shib, 2,8 ga ko'paytirilsa, 95,2 hosil bo'ladi. Men o'ylagan sonni toping.
- 1069.** Maktab oshxonasining bo'yi 29,8 m, eni esa 15 m. Maktab oshxonasining yuzini toping. Javobni yuzdan birgacha yaxlitlang.
- 1070.** Xonaning eni 5,5 m, bo'yi esa xonaning enidan ikki marta uzun. Agar xonaning balandligi 3,5 m bo'lsa, uning hajmini toping.
- 1071.** Do'kon uch kunda 1289,7 kg un sotdi. Birinchi kuni 321,3 kg, ikkinchi kuni uchinchi kunga qaraganda 3 marta ko'p un sotildi. Uchinchi kuni necha kilogramm un sotilgan?
- 1072.** Kater oqimga qarshi harakat qilib, 4 soatda 143,5 km yo'l bosdi. Agar oqimning tezligi 3,2 km/soat bo'lsa, katerning o'z tezligini toping.

- 1073.** Agar  $x = 1; 10; 3; 100; 1000; 10\ 000$  bo'lsa,  $53,6x$  ifodaning qiymatini toping.
- 1074.** Agar: a)  $a = 6,328, b = 63$ ; b)  $a = 0,532, b = 52$  bo'lsa,  $a \cdot 100 + 9$  ifodaning qiymatini toping.
- 1075.** Agar 15 ta bir xil jismning massasi 21,8 kg ekanligi ma'lum bo'lsa, 28 ta shunday jismning massasini toping.
- 1076.** Ikki qutida 16,8 kg choy bor. Agar birinchi qutidan ikkinchisiga 0,9 kg choy olib solinsa, ikkala qutidagi choy teng bo'ladi. Har qaysi qutida qancha choy bor?
- 1077.** 74,3 m mato ikki bo'lakka bo'lindi. Birinchi bo'lakda ikkinchisiga qaraganda 2,6 m ko'p mato bor. Har qaysi bo'lakda necha metr mato bor?
- 1078.** Ikki yashikda teng miqdorda pomidor bor. Agar birinchi yashikdan 4,5 kg pomidor olinsa, ikkinchisida 2 marta ko'p pomidor bo'ladi. Ikkala yashikda qancha pomidor bor?
- 1079.** 1 litr sutdan 200 gramm qaymoq olinadi. 1 kg qaymoq olish uchun necha litr sut kerak bo'ladi?
- 1080.** Qutiga har birining massasi  $m$  g bo'lgan  $n$  dona banka solingan bo'lsa, uning massasi  $M = m \cdot n$  formula orqali ifodalanadi. Bu formuladan foydalanib, quyidagi jadvalni to'ldiring:

$M$		6 kg	3000 g	8,4g		9,6 kg
$m$	0,25 kg		150 g		480 g	0,8 kg
$n$	12	6		24	10	

- 1081.** Asalari 200 g asal yig'ish uchun 2 mln gulga qo'nadi. Asalari bitta guldan qancha gramm asal oladi?
- 1082.** Oynaning bo'yi 6,32 m, eni 3,09 m. Oynaning yuzi nimaga teng? Javobni o'ndan birgacha yaxlitlang.
- 1083.** 1 kg guruch 2800 so'm turadi. a) 2,3 kg; b) 1,5 kg; d) 0,8 kg; e) 0,2 kg guruch qancha turadi?
- 1084.** Mashina 37,5 km/soat tezlik bilan 9,2 soatda necha kilometr yuradi? 2,23 soatda-chi?
- 1085.** 1  $\text{sm}^3$  oltinning massasi 6,72 g. Hajmi 5,2  $\text{sm}^3$  bo'lgan oltin parchasining massasini toping.
- 1086.** Agar to'g'ri to'rtburchakning o'lchamlari: a) 7,1 sm; 5,2 sm; b) 0,83 sm; 1,34 sm bo'lsa, uning yuzini toping.
- 1087.** 1,8 kg olxo'ri va 2,3 kg o'rik sotib olindi. 1 kg olxo'ri 3,5 ming so'm turadi. O'rik narxi olxo'ri narxidan 1,4 ming so'm qimmat. Xarid uchun jami qancha pul to'langan?
- 1088.** Birinchi bog'da 163 tup daraxt bor, ikkinchi bog'da esa undan 35 tup ko'p daraxt bor. Har bir daraxtdan o'rtacha 6,8 kg dan hosil olinsa, ikkala bog'dan jami qancha hosil olinadi?

- 1089.** Kompyuter monitori diagonalining o'lchami: a) 17; b) 19; d) 21 duym. Agar 1 duym 2,54 sm ga teng bo'lsa, monitor o'lchamini santimetrlarda ifodalang.
- 1090.** 2010- yili AQSH da yaratigan «Terrafugia» uchar avtomobili 270 km masofaga ucha oladi. Bu aeromobil havoda 185 km/soat tezlikda necha soat parvoz qila oladi?
- 1091.** Uzoq masofaga yugurish – marafon masofasi 42 km 195 m ni tashkil qiladi. Bu masofani dunyoda eng tez bosib o'tgan kishi — efiopiyalik sportchi Xayle Gebreselassi hisoblanadi. U bu masofani 2 soat 3 minut 59 sekundda bosib o'tgan. Xayle bu masofani o'rtacha qanday tezlikda bosib o'tgan?
- 1092.** Abdurahmonda 4500 so'm, Ashrafda 1700 so'm, Mahmudda esa 2800 so'm pul bor. Ular pullarini qo'shib, kinoga 3 ta chipta olishdi. Bitta chipta narxi qancha?

### Bilimingizni sinab ko'ring!



Bu bob materiallarini o'rganib chiqib, quyidagi masalalarni yecha olishingiz shart! Nazorat ishi oldidan o'zingizni sinab ko'ring!

**Test.** To'g'ri javobni aniqlang.

- O'nli kasrni 0,001 ga bo'lish uchun o'nli kasrdagi vergulni qayerga surish kifoya?  
A. Chapga 2 xona; || B. Chapga 3 xona; || D. O'ngga 3 xona; || E. O'ngga 2 xona.
- Kasr sonni 0,01 ga bo'lish uni qanday songa ko'paytirish demakdir?  
A. 100; || B. 10; || D. 1000; || E. 0,01.
- $0,2209 \cdot 412,038$  ko'paytmada verguldan keyin nechta raqam bo'ladi?  
A. 4 ta; || B. 6 ta; || D. 7 ta; || E. 3 ta.

### 11- nazorat ishi namunasi

- Hisoblang:  
a)  $0,872 \cdot 6,3$ ; || b)  $1,6 \cdot 7,625$ ; || d)  $0,045 \cdot 0,1$ ;  
e)  $30,42 : 7,8$ ; || f)  $0,702 : 0,065$ ; || g)  $0,026 : 0,01$ .
- Sonlarning o'rta arifmetigini toping:  
32,4; 41; 27,95; 46,9; 55,75.
- Ifodaning qiymatini toping:  $296,2 - 2,7 \cdot 6,6 + 6 : 0,15$ .
- Poyezd 63,2 km/soat tezlik bilan 3 soat, 76,5 km/soat tezlik bilan 4 soat yurdi. Poyezdning butun yo'ldagi o'rtacha tezligini toping.
- Uchta sonning yig'indisi 10,23 ga teng. 6 ta boshqa sonlarning o'rta arifmetigi 2,9 ga teng. Barcha 9 ta sonning o'rta arifmetigini toping.



**VIII BOB. FOIZLAR**

**46- §. FOIZ HAQIDA TUSHUNCHA**

Qadimdan turmushda ko'p ishlatiladigan ulushlar maxsus nomlar bilan atalgan. Masalan, ikkidan birning – yarim, to'rttdan birning – chorak, sakkizdan birning – nimchorak deb atalishini bilamiz. Yuzdan bir ulush ham maxsus nom bilan yuritiladi va u *foiz* deb ataladi.

«Foiz» so'zi radio va televideniye xabarlarini orqali tez-tez qulog'ingizga chalingan bo'lsa kerak. Masalan, saylovga saylovchilarning 93 foizi qatnashdi, oylik maoshlar 20 foizga oshirildi, shahar transportida yurish chiptasi narxi 10 foizga oshirildi va hokazo.

Miqdorning (sonning) yuzdan bir ulushi uning *bir foizi* deb ataladi.

Masalan, 400 km ning 1 foizi – 4 km, chunki 400 ning yuzdan bir ulushi:  
 $400 : 100 = 4$ .

1 kg ning 1 foizi – 10 g, chunki 1 kg = 1000 g va 1000 ning yuzdan bir ulushi:  
 $1000 : 100 = 10$ .

350 ning 1 foizi – 3,5, chunki 350 ning yuzdan bir ulushi:  $350 : 100 = 3,5$ .

Ba'zida «foiz» so'zi o'rniga qulaylik uchun «%» belgi ishlatiladi.

**!** 1 foiz — sonning (miqdorning) yuzdan bir ulushi bo'lgani uchun, bu sonning (miqdorning) o'zi – 100 foizga teng bo'ladi.

Shunday qilib,

$$1\% = \frac{1}{100} = 0,01$$

$$100\% = 1$$

*1- misol.* Asakadagi avtomobil zavodi bir haftada 840 ta avtomobil ishlab chiqardi. Ularning 20 foizi «Spark» avtomobilidir. Zavod bir haftada nechta «Spark» avtomobili ishlab chiqargan?

*Yechish:* 840 ta avtomobilni 100 % desak, uning 1 foizi, yani yuzdan bir ulushi:

$$840 : 100 = 8,4.$$

Avtomobillarning 20 foizini topish uchun 8,4 ni 20 ga ko'paytiramiz :  $8,4 \cdot 20 = 168$ .

**Javob:** Asaka zavodi bir haftada 168 ta «Spark» avtomobili ishlab chiqargan.



**2- misol.** Novvoyxonada yopilgan 1800 ta nonning 75 foizi ertalab sotildi. Ertalab nechta non sotilgan?

**Yechish:** 1800 ta nonning 1 foizi:  $1800 : 100 = 18$  (ta non) bo'ladi. Barcha nonning 75 foizini topish uchun 18 ni 75 ga ko'paytiramiz:  $18 \cdot 75 = 1350$  (ta non).

**Javob:** Ertalab 1350 ta non sotilgan.

Sonni foizga aylantirish uchun uni 100 ga ko'paytirish kifoya.

Foizni songa aylantirish uchun esa uni 100 ga bo'lish kifoya.



Masalan, a)  $0,832 = 0,832 \cdot 100\% = 83,2\%$ ;      b)  $1,78 = 1,78 \cdot 100\% = 178\%$ ;  
 d)  $56\% = 56 : 100 = 0,56$ ;                      e)  $239\% = 239 : 100 = 2,39$ .

Ba'zida foizlarni songa aylantirib ish ko'rishga ham to'g'ri keladi. Masalan, biror miqdorning 45 foizini topish uchun bu miqdorning  $\frac{45}{100}$  qismini topish, ya'ni uni 0,45 ga ko'paytirish kifoya.

*Miqdorning (sonning) p foizini topish uning  $\frac{p}{100}$  qismini topish demakdir.*

### Savollarga javob bering!



1. Foiz deb nimaga aytiladi?
2. Miqdorning yuzdan bir ulushi – 1% bo'lsa, miqdorning o'zi necha foiz bo'ladi?
3. Sonning foizi qanday topiladi?
4. O'nli kasrni foizga aylantirish uchun nima qilish kerak?
5. Foizni o'nli kasrga aylantirish uchun nima qilish kerak?

### Sinfda bajariladigan mashqlar



**1093.** Kvadrat yuzining necha foizi bo'yalgan?

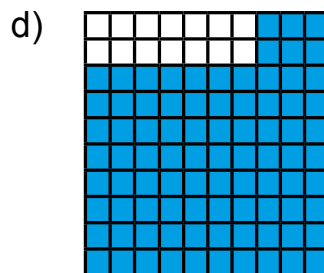
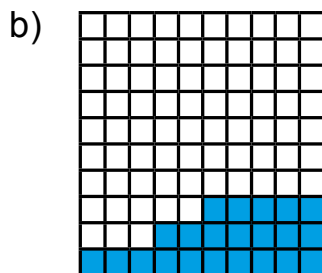
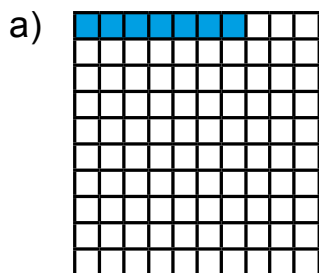

**1094.** Foizlarda ifodalang:

- a) saylovchilarning  $\frac{97}{100}$  qismi;                      b) shahar aholisining  $\frac{68}{100}$  qismi;  
d) kutubxonadagi kitoblarning 0,12 qismi;    e) hosilning 0,26 qismi.

**1095.** Quyidagi jumalarni foiz so'zini ishlatib qayta ayting:

- a) Har 100 ta chaqaloqning 52 tasi o'g'il bola;  
b) Har 100 ta o'quvchining 74 tasi to'garaklarga qatnashadi;  
d) Har 100 ta avtomobilning 75 tasi yurtimizda ishlab chiqarilgan;  
e) Har 10 ta kishining 8 tasida qo'l telefoni bor.

**1096.** Miqdorning 1 foizini toping:

- a) 200 m; || b) 2500 so'm; || d) 400 km; || e) 1500 kg; || f) 3800 t; || g) 10 000 mm.

**1097.** Qishloqda 12 000 aholi istiqomat qiladi. Qishloq aholisining:

- a) 1; b) 5; d) 12; e) 20; f) 50; g) 75; h) 95 foizi necha kishini tashkil qiladi?

**1098.** 1 km ning: a) 1; b) 5; d) 12; e) 25; f) 100 foizini toping;

**1099.** O'zbekiston Respublikasining yer maydoni quruqlikning taxminan 0,3 foizini tashkil qiladi. Agar Yer yuzidagi quruqlikning maydoni 149, 633 million km<sup>2</sup> bo'lsa, mamlakatimiz yer maydonini toping.



**1100.** Ishchi 220 000 so'm mukofot oldi. U mukofotning yuzdan bir qismiga o'g'li uchun sovg'a oldi. Sovg'a qancha turadi?

**1101.** Do'konga 850 kg bodring keltirildi. Birinchi xaridor hamma bodringning 1 foizini, ikkinchisi hamma bodringning 3 foizini sotib oldi. Har qaysi xaridor necha kilogramm bodring sotib olgan?

**1102.** Do'kondagi 700 kg olmaning 30 foizi sotildi. Necha kilogramm olma sotilgan? Do'konda necha foiz olma qolgan?

**1103.** Maydoni 620 ga bo'lgan dalaga paxta terish mashinalari chiqarildi. Ular bir kunda dalaning 35 foizidagi paxtani terdi. Bir kunda necha gektardagi paxta terilgan?

**1104.** Ishchilarga 760 m uzunlikdagi yo'lni ta'mirdan chiqarish topshirildi. Agar ular topshiriqning: a) 30; b) 50; d) 100 foizini bajargan bo'lsa, necha metr yo'l ta'mirdan chiqarilgan?



### Uyda bajariladigan mashqlar

**1105.** Miqdorlarning 1 foizini toping:

- a) 600 m; || b) 6500 so'm; || d) 8354 t; || e) 68 m; || f) 15 s; || g) 650 000 mm.

**1106.** Shaharda 220 000 aholi istiqomat qiladi. Shahar aholisining: a) 1; b) 8; d) 182; e) 25; f) 60; g) 75; h) 95 foizi necha kishini tashkil qiladi?

**1107.** Yer yuzi aholisi 2015- yil boshiga kelib 7 262 820 500 kishiga yetdi. O'zbekistonda Yer yuzi aholisining taxminan 0,4216 foizi yashaydi. O'zbekiston aholisi bu paytda taxminan qanchani tashkil qilgan?



**1108.** Talaba 120 000 so‘m stipendiya oldi. U bu stipendiyaning 2 foiziga o‘quv qurollari sotib oldi. Talaba sotib olgan o‘quv qurollari qancha turadi?

**1109.** Amallarni bajaring:

- a)  $40,27 \cdot (6,38 + 7,62) - (47,45 + 9,25) : 21$ ;  
 b)  $21,38 \cdot (324,6 - 224,6) + 2643,3 - 2643,3 : 33$ ;  
 d)  $10,12 - 8,12 : (6,38 - 2,38)$ .

### Oilada tejamkorlik va matematika



**1110.** Quyidagi jadvalda oilaning 5 kun davomida elektr quvvatini iste‘mol qilish ko‘rsatkichlari keltirilgan. Bu ma‘lumotlardan foydalanib, jadvalning bo‘sh kataklarini to‘ldiring (1 kilovatt·soat elektr energiya narxi 144,3 so‘m). Shunga o‘xshash jadvalni o‘z oilangiz misolida ham tuzing va xulosa qiling.

Sana	Hisoblagich ko‘rsatkichi (kilovatt·soat)	Elektr energiyasi sarfi (kilovatt·soat)	Elektr energiyasi uchun to‘lov (so‘m)
14.01.2015 yil.	8774	9	
15.01.2015 yil.	8779	5	
16.01.2015 yil.	8785	6	
17.01.2015 yil.	8793	8	
18.01.2015 yil.	8801	8	
O‘rtacha bir kunda			
O‘rtacha bir oyda			
O‘rtacha bir yilda			

### Matematika tarixiga oid lavhalar



«%» – foiz belgisi XVII asrdan boshlab ishlatila boshlagan. 1685- yilda fransuz matematigi Mat’e de la Portning «Tijorat arifmetikasi bo‘yicha qo‘llanma» kitobi nashrdan chiqdi. Unda foizlar haqida ham so‘z borgan. O‘sha paytlarda foiz – «cento» (yuzdan) so‘zining qisqartmasi uchta harf: «cto» bilan belgilanar edi. Lekin bosmaxonada harf teruvchi adashib «cto» o‘rniga «%» deb bosib yuborgan. Shu tariqa matematikaga biz hozir ham ishlatayotgan «%» – foiz belgisi kirib kelgan.

### Qiziqarli matematikaga oid masalalar



1. Son oldin 10 foizga orttirildi. So‘ng yana 10 foizga orttirildi. Dastlabki son necha foizga ortdi?
2. Son oldin 10 foizga kamaytirildi. So‘ng yana 10 foizga kamaytirildi. Dastlabki son necha foizga kamaytirildi?
3. Son oldin 10 foizga orttirildi. So‘ng 10 foizga kamaytirildi. Natijada dastlabki son ortdimi yoki kamaydimi? Necha foizga?

## 47- §.

## FOIZLARGA DOIR MASALALAR YECHISH

**1- misol.** Abdurahmon kitobning 36 betini o'qib chiqdi. Bu kitobning 18 foizini tashkil qiladi. Kitob necha betdan iborat?

**Yechish:** Shartga ko'ra kitobning 18 foizi – 36 bet. Unda kitobning 1 foizi:  $36 : 18 = 2$  betni tashkil qiladi. Endi kitobning hamma betlari sonini, ya'ni 100 foizini topamiz. Buning uchun 2 ni 100 ga ko'paytiramiz:  $2 \cdot 100 = 200$  (bet).

**Javob:** Kitob 200 betdan iborat.

**2- misol.** Saylovda 11 570 kishi qatnashib, bu butun uchastka saylovchilarining 89 foizini tashkil qildi. Saylov uchastkasida qancha saylovchi bor?

**Yechish:** Shartga ko'ra saylovchilarning 89 foizi – 11 570 kishi. Unda saylovchilarning 1 foizi:  $11\,570 : 89 = 130$  kishini tashkil qiladi.

Barcha saylovchilar sonini topish uchun 130 ni 100 ga ko'paytiramiz:

$$130 \cdot 100 = 13\,000 \text{ (kishi).}$$

**Javob:** Saylov uchastkasida 13 000 saylovchi bor.

**3- misol.** 300 gektarlik dalaning 225 gektari haydaldi. Dalaning necha foizi haydalgan?

**Yechish:** Shartga ko'ra dalaning  $\frac{225}{300}$  qismi haydalgan. Bu kasrni o'nli ko'rinishda ifodalaymiz. Buning uchun 225 ni 300 ga bo'lamiz. Natijada 0,75 ni hosil qilamiz.

Demak, dalaning 75 ta yuzdan bir ulushi haydalgan. Yuzdan bir ulush 1% ekanligini hisobga olsak, dalaning 75 foizi haydalgan bo'lib chiqadi.

**Javob:** Dalaning 75 foizi haydalgan.

**4- misol.** Stadion 50 000 kishiga mo'ljallangan. Navbatdagi futbol o'yinini 32 500 ta ishqiboz tomosha qildi. Bu o'yinda stadionning necha foiz o'rindiqlari band bo'lgan?

**Yechish:** 32 500 ni 50 000 ga bo'lamiz va bo'linmani foizlarda ifodalaymiz:

$$\frac{32\,500}{50\,000} = 0,65; \quad 0,65 = 0,65 \cdot 100\% = 65\%.$$

**Javob:** Stadionning 65% o'rindiqlari band bo'lgan.

**5- misol.** Abdullayev bankka 50 000 so'm pul qo'ydi. Bank Abdullayevga bu pulni 1 yilda 25 foizga ko'paytirib qaytaradigan bo'ldi. Bir yilda Abdullayev puli qanchaga ko'payadi? U bankdan 1 yildan keyin qancha pul qaytarib oladi?

**Yechish:** Omonatning – 1 foizi:  $50\,000 : 100 = 500$  (so'm);

25 foizi:  $500 \cdot 25 = 12\,500$  (so'm) bo'ladi.

Demak, Abdullayevning omonati 1 yilda 12 500 so'mga ko'payib, u yil oxirida bankdan  $50\,000 + 12\,500 = 62\,500$  so'm qaytarib oladi.

**Javob:** 12 500 so'm, 62 500 so'm.

**6- misol.** Do'kondagi 30 000 so'mlik ko'ylak narxi 15 foizga arzonlashtirildi. Ko'ylak narxi qanchaga arzonlashdi? Ko'ylakning yangi narxi necha so'mni tashkil qiladi?

**Yechish:** Ko'ylak eski narxining 1 foizi:  $30\ 000 : 100 = 300$  (so'm);  
15 foizi:  $300 \cdot 15 = 4\ 500$  (so'm) bo'ladi.

Demak, ko'ylak narxi 4500 so'mga arzonlashib, yangi narx  $30\ 000 - 4500 = 25\ 500$  so'mni tashkil qilgan.

**Javob:** 4 500 so'm, 25 500 so'm.

**7- misol.** Bozorda go'sht narxi — 25 000 so'm bo'lib, u 10 foizga qimmatlashdi. Go'shtning yangi narxi qancha bo'ladi?

**Yechish:** Go'sht narxining 1 foizi:  $25\ 000 : 100 = 250$  (so'm);  
10 foizi:  $250 \cdot 10 = 2500$  (so'm) bo'ladi.

Demak, bozorda go'sht narxi 2500 so'mga qimmatlashib, yangi narx  $25\ 000 + 2500 = 27\ 500$  so'mni tashkil qilgan.

**Javob:** 27 500 so'm.

### Savollarga javob bering!



1. Sonning foiziga ko'ra o'zi qanday topiladi?
2. Bir son ikkinchi sonning necha foizini tashkil qilishi qanday topiladi?

### Sinfda bajariladigan mashqlar



- 1111.** Dalaning 1 foiziga no'xat ekildi. Agar 3,25 ga yerga no'xat ekilgan bo'lsa, butun dalaning yuzini toping.
- 1112.** Agar zalda hozir bo'lganlarning 1 foizi – 7 kishini tashkil qilsa, zalda necha kishi bor?
- 1113.** Mototsiklchi bir kunda ma'lum masofani bosib o'tdi. Bu masofaning 1 foizi 3,2 km bo'lsa, butun masofani toping.
- 1114.** Hovli yuzining 4 foizi mashina turishi uchun ajratilgan. Mashina turadigan maydon  $38,4\ m^2$  ga teng bo'lsa, hovlining yuzini toping.
- 1115.** Neftni haydaganda 30% kerosin olinadi. Agar: a) 21 t; b) 12 t; d) 42,3 t kerosin olingan bo'lsa, qancha neft haydalgan?
- 1116.** Bug'doydan 80% un olinadi. Agar 440 kg un olingan bo'lsa, qancha bug'doy tegirmonda yanchilgan? 2,5 t bug'doydan qancha un olinadi?
- 1117.** Ra'no pulining 60 foiziga kitob sotib oldi. Qolgan 2000 so'miga esa kinoga bilet oldi. Ra'noda qancha pul bo'lgan?



- 1118.** Bog'dagi 850 tup daraxtning 680 tasi mevali daraxt. Mevali daraxtlar bog'dagi daraxtlarning necha foizini tashkil qiladi?

1119. Jadvalni to'ldiring.

Foiz	1%	3%	10%	20%	25%	28%	45%	50%	63%	75%	80%	95%
Oddiy kasr												
O'qli kasr												

1120. Ishchi reja bo'yicha 35 ta detal yasashi kerak edi. Lekin u rejadan ortiqcha 14 ta detal yasadi. Ishchi rejani necha foizga bajargan?

1121. a) 30 soni 40 ning; b) 63 soni 75 ning; d) 114 soni 142,5 ning; e) 4,71 soni 31,4 ning; f) 36,9 soni 12,3 ning qanday foizini tashkil qiladi?

*Namuna:* a)  $30 : 40 = 0,75 = 0,75 \cdot 100\% = 75\%$ .

1122. Agar eritma 60 g tuz va 140 g suvdan tayyorlangan bo'lsa, eritmada necha foiz tuz bor?

1123. Palto 64 000 so'm turadi. Birinchi marta uning narxi 10 foizga, ikkinchi marta esa 1800 so'mga arzonlashtirildi. Ikkinchi marta palto narxi necha foizga tushirilgan?

1124. Buyurtmaga ko'ra usta 8 soatda 80 ta detal yasashi kerak edi. 7 soatdan so'ng usta hamma detalning 90 foizini yasadi. Usta shunday mehnat unumi bilan ishlab, buyurtmani o'z vaqtida bajara oladimi?

1125. Bronza qalay bilan misning qotishmasidan iborat. 6 kg qalay va 34 kg misdan iborat bronzada mis qotishmaning necha foizini tashkil qiladi?

1126. a) 32 soni 40 dan necha foizga kichik? b) 40 soni 32 dan necha foizga katta?



### Uyda bajariladigan mashqlar

1127. Fermada 250 bosh sigir va buzoq bor. Buzoqlar butun mollarning 22 foizini tashkil qiladi. Fermada nechta buzoq bor?

1128. G'ishtni tashishda uning 2 foizi sindi, bu esa 1500 tani tashkil qildi. Jami nechta g'isht tashilgan?

1129. Bir qopda 80 kg un bor, ikkinchisida undan 20% kam. Ikkinchi qopda qancha un bor?

1130. Chilangar bilan shogirdi 1200 ta detal tayyorladi. Shogirdi hamma detalning 30 foizini tayyorladi. Chilangar nechta detal tayyorlagan?



1131. 220 ta ot va toy haydab kelindi. Toylar butun yilqining 15 foizini tashkil qiladi. Yaylovga nechta toy haydab kelingan?

1132. Yer yuzi maydoni 510,1 mln km<sup>2</sup> ga teng bo'lib, uning 22,9 foizini quruqlik, qolganini esa suv tashkil qiladi. Yer yuzining taxminan qanday maydoni suv bilan qoplangan?

- 1133.** Shirin choy hosil qilish uchun 200 grammlik stakanga 2 choy qoshiq shakar solinadi. Agar bitta choy qoshiqdagi shakar massasi 10 g bo'lsa, shirin choyda necha foiz shakar bor?
- 1134.** Sinfda 40 o'quvchi bor. O'g'il bolalar sinfdagi hamma o'quvchining 55 foizini tashkil qiladi. Sinfda qizlar necha foizni tashkil qiladi? Sinfda necha nafar qiz o'qiydi?
- 1135.** Sutdan 10 % qaymoq olinadi. 32,8 kg sutdan qancha qaymoq olinadi? 58,7 kg sutdan-chi?
- 1136.** Qo'ziqorin quritilganda massasining 79 foizini yo'qotadi. Agar 20 kg qo'ziqorin quritilsa, qancha quritilgan qo'ziqorin qoladi?

**Bilimingizni sinab ko'ring!**



Bu bob materiallarini o'rganib chiqib, quyidagi masalalarni yecha olishingiz shart! Nazorat ishi oldidan o'zingizni sinab ko'ring!

**12- nazorat ishi namunasi**

1. Maydon yuzi 260 ga. Uning 35 foiziga piyoz ekilgan. Piyoz qancha maydonga ekilgan?
2. Ifodaning qiymatini toping:  $201 - (176,4 : 16,8 + 9,68) \cdot 2,5$ .
3. Kutubxonadagi kitoblarning 12 foizini lug'atlar tashkil qiladi. Agar lug'atlar soni 900 ta bo'lsa, kutubxonada jami qancha kitob bor?
4. Tenglamani yeching:  $12 + 8,3x + 1,5x = 95,3$ .
5. Sim o'rami 72 m bo'lib, undan 18 m sim qirqib olindi. Sim o'ramida simning necha foizi qoldi?

**Qiziqarli matematikaga oid masalalar**



3 va 5 litrlik idishlar bor. Ular yordamida suv quvuridan 4 litr suv quyib olish mumkinmi?



**48.1. Burchak tushunchasi**

$O$  nuqtadan chiquvchi ikkita:  $OA$  va  $OB$  nurlarni chizamiz (1-rasm).

Bir nuqtadan chiquvchi ikkita nurdan iborat shaklga *burchak* deyiladi. Nurlar chiqqan nuqta *burchakning uchi*, nurlar esa *burchakning tomonlari* deb ataladi.

1-rasmda burchak tasvirlangan. Unda  $O$  nuqta burchakning uchi,  $OA$  va  $OB$  nurlar esa uning tomonlaridan iborat. Bu burchak yozuvda « $AOB$  burchak» yoki « $BOA$  burchak» tarzida ifodalanadi. Ko'rib turganingizdek, bu yozuvlarda burchakning uchini belgilovchi  $O$  harfi o'rtada yoziladi.

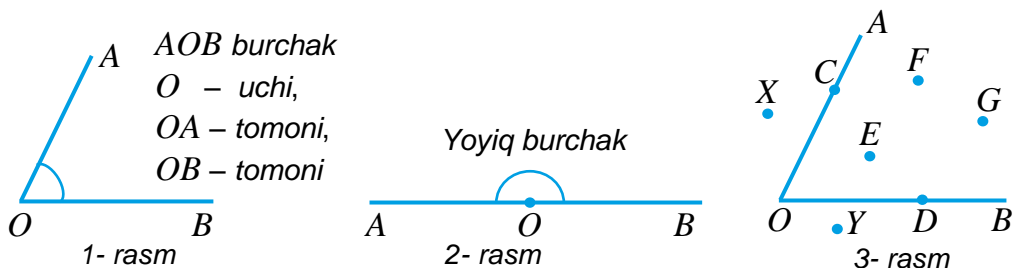

Shuningdek, burchak uning uchi belgilangan harf bilan ham qisqaroq ifodalanishi mumkin. Masalan, « $O$  burchak» tarzida. Ba'zida burchak so'zi o'rnida « $\angle$ » belgi ishlatiladi. Bu holda, burchak  $\angle AOB$ ,  $\angle BOA$  yoki  $\angle O$  tarzida belgilanadi. Rasmda burchak yoycha bilan ajratib ko'rsatilishi mumkin.

$AB$  to'g'ri chiziqda  $O$  nuqtani belgilaymiz (2-rasm). Natijada  $AO$  va  $OB$  nurlar hosil bo'ladi.  $O$  nuqtadan chiquvchi bu ikki nur burchak tashkil qiladi. Bu burchak *yoyiq burchak* deb ataladi.

3-rasmda  $AOB$  burchak va bir nechta nuqtalar tasvirlangan. Bu nuqtalar haqida gap ketganda,  $C$  va  $D$  nuqtalar –  $AOB$  burchak tomonlarida,  $E$ ,  $F$  va  $G$  nuqtalar – burchakning ichki sohasida,  $X$  va  $Y$  nuqtalar esa burchakning tashqi sohasida yotibdi, deb aytamiz.

**48.2. Burchaklarni taqqoslash**

4- rasmda yelpig'ichning turli holatlari tasvirlangan. Bu rasmlarning qaysi birida yelpig'ich end katta burchakka ochilgan? Qaysi birida eng kichik burchakka ochilgan? Bu savollarga javob berish uchun burchaklarni o'zaro taqqoslashni bilishimiz zarur.

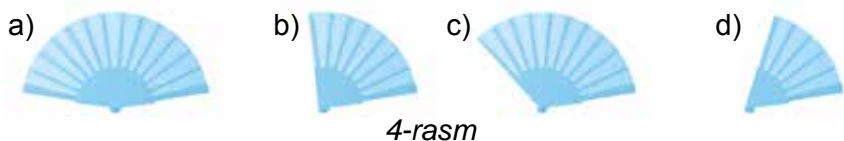

Ikkita burchakni o'zaro taqqoslash – birini ikkinchisining ustiga qo'yish orqali amalga oshiriladi.

Agar bir burchakni ikkinchisining ustiga ustma-ust tushadigan qilib qo'yish mumkin bo'lsa, bu burchaklar *teng burchaklar* deb ataladi.

5-rasmdagi  $A$  burchakni  $B$  burchakning ustiga qo'yganda (5a-rasm), ular roppa-rosa ustma-ust tushmoqda (5b-rasm).

Demak, bu burchaklar o'zaro teng. Bu  $\angle A = \angle B$  tarzida yoziladi. Teng burchaklar rasmda bir xil sondagi yoychalar bilan ajratib ko'rsatiladi.

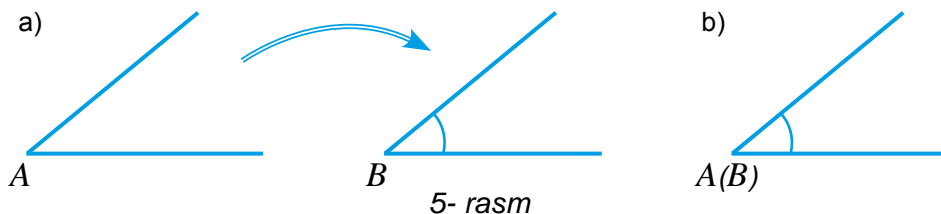

5- rasm

$AOB$  burchakning  $O$  uchidan  $OE$  nur o'tkazamiz (6a-rasm).  $OE$  nur burchakni  $AOE$  va  $EOB$  burchaklarga ajratadi va  $\angle AOB = \angle AOE + \angle EOB$  tenglik o'rinli bo'ladi. Shuningdek, bu burchakning har biri  $AOB$  burchakdan kichik bo'ladi va bu quyidagicha yoziladi:

$$\angle AOE < \angle AOB, \quad \angle EOB < \angle AOB.$$

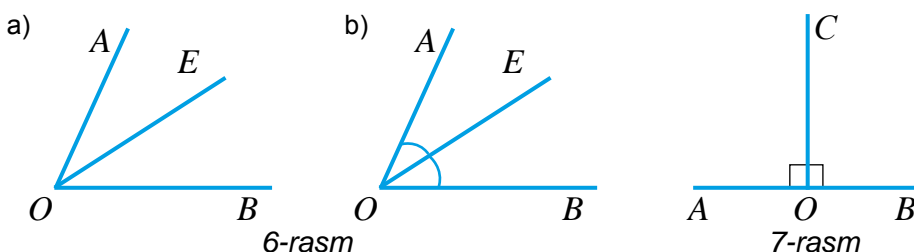

6-rasm

7-rasm

Agar  $AOE$  va  $EOB$  burchaklar teng bo'lsa (6.b-rasm),  $OE$  nur  $AOB$  burchakni teng ikkiga bo'ladi. Burchakni teng ikkiga bo'luvchi nur *burchakning bissektrisasi* deb ataladi.

6.b-rasmda  $OE$  nur  $AOB$  burchakning bissektrisasi.

### 48.3. To'g'ri burchak

$AOB$  yoyiq burchakning  $O$  uchidan  $OC$  bissektrisasi o'tkazamiz (7-rasm). Ravshanki, hosil bo'lgan  $AOC$  va  $COB$  burchaklar o'zaro teng bo'ladi:  $\angle AOC = \angle COB$ . Bu burchaklar *to'g'ri burchaklar* deb ataladi. To'g'ri burchak 7- rasmdagidek siniq chiziq bilan ajratib ko'rsatiladi.

Shunday qilib, yoyiq burchak bissektrisasi uni ikkita to'g'ri burchakka ajratar ekan. Bundan quyidagi xulosaga kelamiz:

*To'g'ri burchak yoyiq burchakning yarmiga teng.*



To'g'ri burchaklarni chizish uchun 8-rasmda tasvirlangan uchburchakli chizg'ichdan foydalaniladi. Bir tomoni  $OA$  nurdan iborat to'g'ri burchakni chizish uchun:

1) uchburchakli chizg'ichning to'g'ri burchakli uchi  $O$  nuqtada, bir tomoni esa  $OA$  nurda yotadigan qilib qo'yiladi.

2) chizg'ichning ikkinchi tomoni bo'ylab  $OB$  nur chiziladi.

3) hosil bo'lgan  $AOB$  burchak to'g'ri burchak bo'ladi.

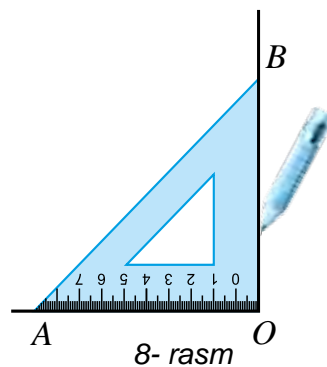

8- rasm

9- rasmda tasvirlangan soatlarning soat va minut millari orasidagi burchaklarni belgilang. Eng katta burchak qaysi rasmda tasvirlangan? Eng kichik burchak qaysi rasmda tasvirlangan? Qaysi rasmlarda teng burchaklar tasvirlangan?

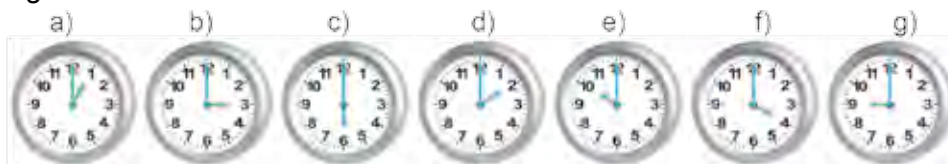

9-rasm



### Savollarga javob bering!

1. Burchak deb nimaga aytiladi?
2. Burchak qanday belgilanadi?
3. Teng burchaklar deb qanday burchaklarga aytiladi?
4. Yoyiq burchakning yarmi qanday burchak bo'lad?



### Sinfda bajariladigan mashqlar

**1137.** 10- rasmda tasvirlangan burchaklarni ayting. Ularning uchi va tomonlarini aniqlang.

**1138.** 11- rasmda tasvirlangan nuqtalarning qaysilari: a) burchakda; b) burchakning ichki sohasida; d) burchakning tashqi sohasida yotadi?

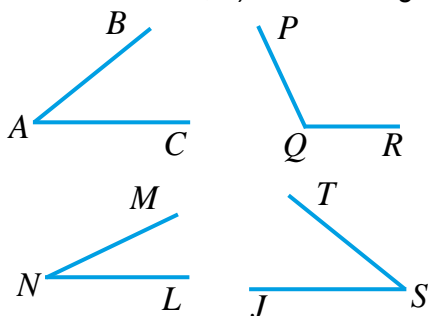

10- rasm

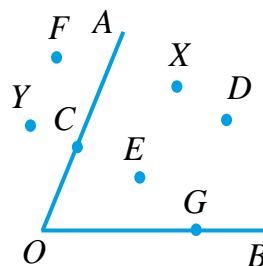

11- rasm

**1139.** Qog'oz varag'iga ikkita burchak chizing va ularni qiyib oling. Bu burchaklarni bir-birining ustiga qo'yish orqali o'zaro taqqoslang.

**1140.** 10- rasmdagi burchaklarni ko'z bilan chamalab, o'zaro taqqoslang. Ularning orasida yoyiq yoki to'g'ri burchaklar bormi?

**1141.** Qog'oz varag'iga biror burchakni chizing. Varaqni bukish orqali uni teng ikkiga bo'ling.

**1142.**  $O$  nuqtadan chiquvchi  $OA$ ,  $OB$ ,  $OC$  va  $OD$  nurlarni chizing. Hosil bo'lgan barcha burchaklarni yozing.



**1143.** 10- rasmda tasvirlangan  $BAC$  burchakning ustiga shaffof qog'oz qo'yib, undan nusxa oling. Andozani qolgan burchaklar ustiga qo'yib, ular orasidan  $BAC$  burchakka: a) teng; b) kichik; d) katta bo'lganlarini aniqlang.



- 1144.**  $CMD$  burchak chizing.  $MN$  va  $ML$  nurlar bilan uni bo'laklarga ajrating. Hosil bo'lgan burchakalarni yozing.
- 1145.** Yoyiq burchak chizing va uni belgilang. Uchburchakli chizg'ich yordamida uni ikkita to'g'ri burchakka bo'ling. Tegishli belgilashlarni bajaring. Yoyiq burchak qaysi burchaklar yig'indisidan iborat ekanligini aniqlang va yozing.
- 1146.** Soatning minut mili qancha vaqtda to'g'ri burchakka buriladi? Qancha vaqtda yoyiq burchakka buriladi (12- rasm)?

**Uyda bajariladigan mashqlar**



- 1147.** 13- rasmda tasvirlangan burchaklarni belgilang va barchasini yozing.

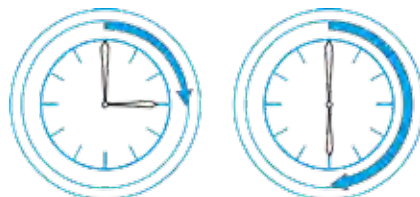

12- rasm

- 1148.** Uchburchakli chizg'ich yordamida 13- rasmda tasvirlangan burchaklar orasidan to'g'ri burchakni toping?



13- rasm

- 1149.** 14- rasmda tasvirlangan  $A$  burchakning ustiga shaffof qog'oz qo'yib, undan nusxa oling. Andoza yordamida qolgan burchaklar orasidan  $A$  burchakka: a) teng; b) kichik; d) katta bo'lganlarini aniqlang.

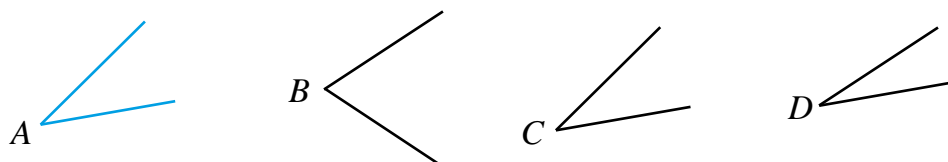

14- rasm



- 1150.**  $O$  nuqtadan chiquvchi  $OP$ ,  $OR$ ,  $OS$  nurlarni chizing. Hosil bo'lgan barcha burchaklarni yozing. Bu nurlar tekislikni nechta bo'lakka ajratadi?
- 1151.** Daftar kataklaridan foydalanib to'g'ri burchak chizing va uni belgilang.
- 1152.** Uchburchakli chizg'ich yordamida: a) tomonlari 4 sm va 6 sm bo'lgan to'g'ri to'rtburchak; b) tomoni 5 sm ga teng kvadrat chizing. Uni belgilang va hosil bo'lgan to'g'ri burchaklarni yozing.
- 1153.** To'g'ri burchak bissektrisasi uni necha gradusli burchaklarga bo'ladi?

Har qanday kattalikni o'lchash uchun o'lchov birligini tanlash lozim bo'ladi. Burchaklarni o'lchash uchun ham oldin o'lchov birligini tanlaymiz.

Yoyiq burchakni uning uchidan chiquvchi nurlar bilan 180 ta teng burchaklarga bo'lamiz (1- rasm). Bu burchaklarning ixtiyoriy bittasini birlik burchak sifatida olamiz. Uning burchak qiymatini «1 gradus» deb olamiz va «1°» tarzida belgilaymiz.

Burchakning gradus o'lchovi uning ichki sohasida birlik burchakning nechtasi joylashishini bildiradi.

Yoyiq burchakning gradus o'lchovi 180° ga teng, chunki uning ichki sohasida 180 ta birlik burchak joylashgan. (2- rasm).

Unda to'g'ri burchak 90° ga teng bo'ladi. Chunki u yoyiq burchaklarning yarmiga teng.

Burchaklar transportir deb nomlangan asbob bilan o'lchanadi. Transportirning asosi chizg'ichdan, yuqori qismi shkalali yarim doira shaklidagi tasmadan iborat (3- rasm). Yarim doira markazi

transportir asosidagi kichkina chiziqcha bilan belgilangan bo'ladi. Uni transportirning markazi deb ataymiz. Transportirning shkalasi chiziqchalar bilan 180 ta teng yoychalarga bo'lingan. Har bir yoycha 1° li burchakni aniqlaydi. 3- rasmda transportir yordamida AOB burchakni o'lchash ko'rsatilgan.

Burchakni o'lchash uchun transportirning asosidagi chizg'ich burchak tomonlaridan birining ustiga, burchak uchi transportir markazi bilan ustma-ust tushadigan qilib qo'yiladi. Shunda, burchakning ikkinchi tomoni transportirning qaysi shkala ko'rsatkichidan o'tsa, burchakning gradus o'lchovi shunga teng bo'ladi.  $\angle AOB = 60^\circ$ .

Teng burchaklarning gradus o'lchovlari ham teng bo'ladi. Ikki burchakdan kattasining gradus o'lchovi katta, kichigining gradus o'lchovi esa kichik bo'ladi.

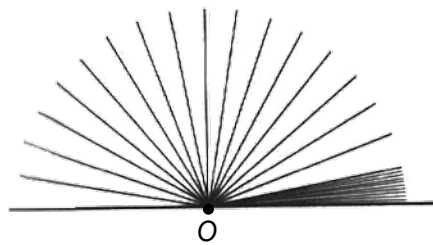

1- rasm

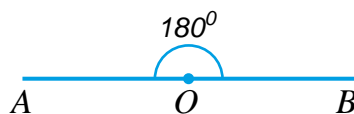

2- rasm

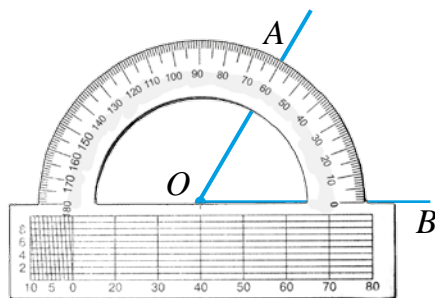

3- rasm

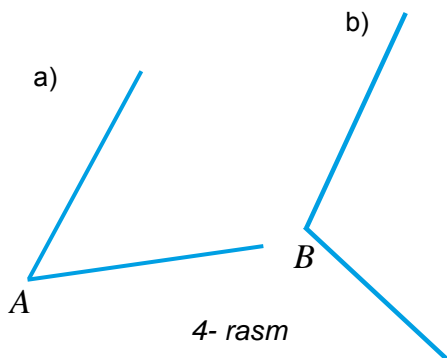

4- rasm

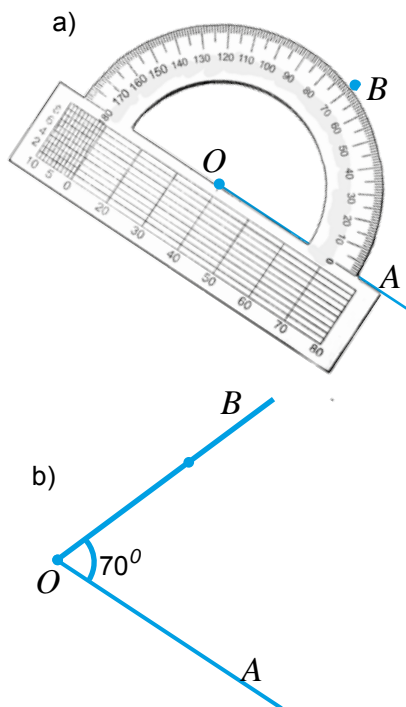

5- rasm

Agar burchakning gradus o'lchovi  $90^0$  dan kichik bo'lsa, bunday burchak *o'tkir burchak* deb ataladi. Gradus o'lchovi  $90^0$  dan katta va  $180^0$  kichik bo'lgan burchakka *o'tmas burchak* deyiladi. 4.a- rasmda o'tkir, 4.b- rasmda esa o'tmas burchak tasvirlangan.

Transportir yordamida berilgan gradus o'lchoviga ega bo'lgan burchaklarni ham yasash mumkin.

*Misol.* Bir tomoni  $OA$  nurdan iborat bo'lgan  $70^0$  li burchak yasang.

*Yechish.* Yasash quyidagicha amalga oshiriladi:

1. Transportir asosidagi chizg'ichni berilgan  $OA$  nurga transportir markazi  $O$  nuqta bilan ustma-ust tushadigan qilib qo'yamiz (5.a- rasm).

2. Transportir shkalasidagi  $70^0$  ga mos chiziqcha to'g'risida  $B$  nuqtani belgilaymiz.

3.  $OB$  nurni o'tkazamiz (5.b- rasm).

Hosil bo'lgan  $AOB$  burchak  $70^0$  li bo'ladi.

Burchak gradus o'lchovining yana boshqa *minut* va *sekund* deb ataluvchi o'lchov birliklari ham bor. 1 gradus 60 minutdan, 1 minut esa 60 sekunddan iborat. Bu  $1^0 = 60'$ ,  $1' = 60''$  tarzida belgilanadi.

### Savollarga javob bering!



1. Burchak o'lchov birligi sifatida nima olinadi?
2. Burchak gradus o'lchovini topish deganda nimani tushunasiz?
3. Yoyiq va to'g'ri burchakning gradus o'lchovi nimaga teng?
4. O'tkir va o'tmas burchaklarga ta'rif bering.
5. Transportir yordamida burchaklar qanday o'lchanishi va yasalishini tushuntirib bering.
6. Yana qanday burchak o'lchov birliklarini bilasiz?



**Sinfda bajariladigan mashqlar**

- 1154.** Qulochingizni yoyib qo'llaringiz bilan: a)  $90^\circ$  li; b)  $180^\circ$  li burchaklarni ko'rsating.
- 1155.** Tik turgan joyingizda: a)  $90^\circ$ ; b)  $180^\circ$  ga buriling;
- 1156.** Soatning minut mili: a) 15 minut; b) yarim soat; d) 1 soatda necha gradusga buriladi?
- 1157.** Gradus o'lchovi berilgan quyidagi burchaklardan qaysi biri o'tkir burchak? Qaysi biri o'tmas burchak?  $22^\circ$ ,  $165^\circ$ ,  $23^\circ$ ,  $90^\circ$ ,  $178^\circ$ ,  $154^\circ$ ,  $101^\circ$ ,  $99^\circ$ .
- 1158.** Ikkita o'tkir va ikkita o'tmas burchak chizing. Ularni belgilang. Transportir yordamida o'lchang va o'lchov natijalarini yozing.
- 1159.** Transportir yordamida: a)  $53^\circ$ ; b)  $47^\circ$ , d)  $105^\circ$ , e)  $173^\circ$  li burchak yasang;
- 1160.** 6- rasmda  $BAC$  burchak  $28^\circ$  ga,  $BAD$  burchak esa  $84^\circ$  ga teng.  $CAD$  burchak gradus o'lchovi nimaga teng?



- 1161.** Daftar kataklaridan foydalanib, a)  $45^\circ$ ; b)  $135^\circ$  li burchak yasang.
- 1162.** Aylana chizing. Daftar kataklaridan foydalanib, uning ikkita radiusini shunday chizingki, ular orasidagi burchak: a)  $45^\circ$ ; b)  $90^\circ$ ; d)  $135^\circ$ ; e)  $180^\circ$  bo'lsin.
- 1163.** 7- rasmdan foydalanib,  $\angle COB$  burchakni toping.

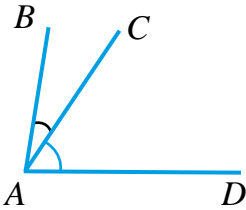

6- rasm

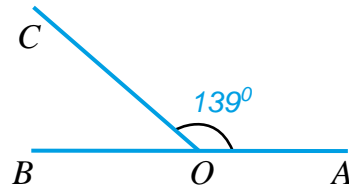

7- rasm

- 1164.** 8- rasmdagi  $\angle AOB$  ning gradus o'lchovi nimaga teng?

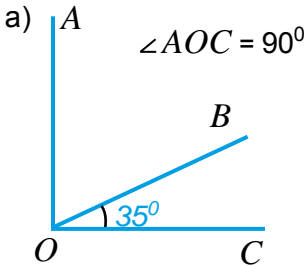

8- rasm

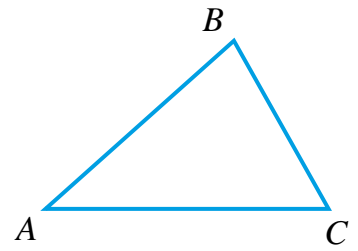
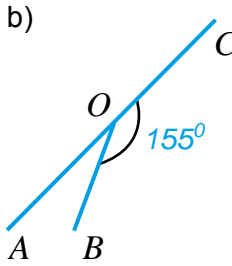

9- rasm

- 1165.** Amaliy ish. 9- rasmda berilgan  $ABC$  uchburchakning  $ABC$ ,  $BCA$  va  $CAB$  burchaklarini transportir yordamida o'lchang. Bu burchaklar yig'indisini hisoblang. Bu ishni boshqa uchburchak chizib, yana bajaring. Natijalarni taqqoslang. Agar aniq o'lchab, to'g'ri hisoblasangiz, uchburchakning quyidagi xossasiga ega bo'lasiz: *uchburchak burchaklari yig'indisi  $180^\circ$  ga teng.*

- 1166.** Uchburchakning ikkita burchagi  $35^{\circ}$  va  $67^{\circ}$ . Yuqoridagi amaliy ish natijasidan foydalanib, uchburchakning uchinchi burchagini toping.
- 1167.**  $\angle AOB = 120^{\circ}$  bo'lib,  $OC$  nur uni ikki bo'lakka bo'ladi. Agar  $AOC$  burchak  $COB$  burchakning 0,2 qismini tashkil qilsa,  $AOC$  burchakni toping.
- 1168.** a)  $21^{\circ}$ ; b)  $43^{\circ}$ ; d)  $16^{\circ} 20'$ ; e)  $31^{\circ} 37' 17''$  ni sekundlarda ifodalang.
- 1169.** a)  $11^{\circ} 30'$ ; b)  $43^{\circ} 40'$ ; d)  $76^{\circ} 20' 30''$  ni graduslarda ifodalang.

**Uyda bajariladigan mashqlar**



- 1170.** Gradus o'lchovi berilgan quyidagi burchaklardan qaysi biri o'tkir burchak? Qaysi biri o'tmas burchak?  $92^{\circ}$ ;  $16^{\circ}$ ;  $145^{\circ}$ ;  $90^{\circ}$ ;  $78^{\circ}$ ;  $132^{\circ}$ ;  $112^{\circ}$ ;  $98^{\circ}$ .
- 1171.** Bitta o'tkir va bitta o'tmas burchak chizing. Ularni belgilang. Transportir yordamida o'lchang va o'lchov natijalarini yozing.
- 1172.** Transportir yordamida: a)  $30^{\circ}$ ; b)  $73^{\circ}$ , d)  $115^{\circ}$ , e)  $135^{\circ}$  li burchak yasang.
- 1173.** 10- rasmdan foydalanib, a)  $AOB$ ; b)  $DOK$ ; d)  $COF$ ; e)  $FOM$ ; f)  $COL$ ; g)  $AOM$ ; h)  $KOE$ ; k)  $LOC$ ; l)  $EOG$ ; burchaklar gradus o'lchovlarini toping.
- 1174.** 11- rasmda  $BAC$  burchak  $136^{\circ}$  ga,  $BAD$  burchak esa  $56^{\circ}$  ga teng.  $CAD$  burchak nimaga teng?

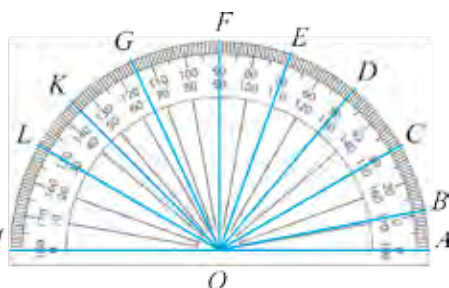

10- rasm

- 1175.** Aylana chizing. Transportirdan foydalanib, uning ikkita radiusini shunday chizingki, ular orasidagi burchak: a)  $60^{\circ}$ ; b)  $120^{\circ}$ ; d)  $30^{\circ}$ ; e)  $150^{\circ}$  bo'lsin.
- 1176.** 12- rasmda  $\angle COD$  – to'g'ri burchak va  $\angle AOC = \angle BOD$  bo'lsa,  $\angle AOC$  ni toping.
- 1177.** 13- rasmdagi  $\angle AOB$  nimaga teng?
- 1178.** Uchburchakning bitta burchagi  $63^{\circ}$ , ikkinchi burchagi esa  $42^{\circ}$  ga teng. 1165- amaliy ish natijasidan foydalanib, uning uchinchi burchagini toping.
- 1179.** a)  $33^{\circ}$ ; b)  $11^{\circ} 10'$ ; d)  $76^{\circ} 12' 39''$  ni sekundlarda ifodalang.

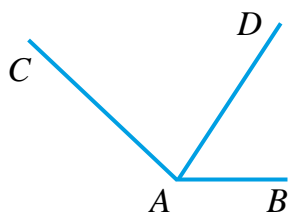

11- rasm

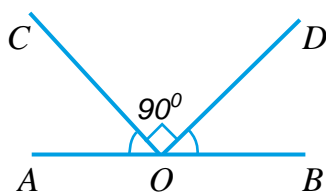

12- rasm

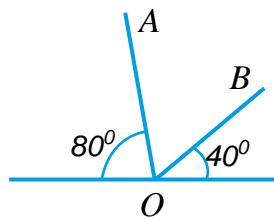

13- rasm

## 50- §

## DOIRAVIY DIAGRAMMALAR VA ULARNI QURISH

Ma'lumotlarni doiraviy diagramma ko'rinishida ham tasvirlash mumkin. Odatda, doiraviy diagrammalar bir butun narsaning tarkibiy qismlari orasidagi munosabatlarni ko'rgazmali qilib tasvirlash uchun tuziladi.

Masalan, maktab jami o'quvchilari sonining sinflar bo'yicha taqsimlanishi, mamlakat aholisining milliy tarkibi, oilaning jami xarajatlaridagi turli xil xarajatlarning ulushi, qotishmadagi turli metallar ulushini tasvirlovchi doiraviy diagrammalar va hokazo.

*1- misol.* Massasi 12 kilogramm bo'lgan aralashmaning 2 kilogrammini tuz, qolganini suv tashkil qiladi. Bu ma'lumotlar asosida doiraviy diagramma tuzing.

*Yechish.* Doira markazini yoyiq burchakning uchi deb olsak, butun doirani ikkita  $180^{\circ}$  li yoyiq burchak qoplaydi (1- rasm).

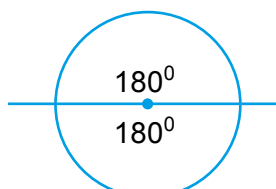

1- rasm

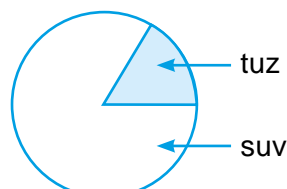

2- rasm

Demak, butun doiraning gradus o'lchovini  $2 \cdot 180^{\circ} = 360^{\circ}$  deb olsak bo'ladi.

Masala shartiga ko'ra, 12 kg aralashmani butun doira ( $360^{\circ}$ ) kabi tasvirlaymiz. U holda, 1 kilogrammik aralashmaga  $360 : 12 = 30^{\circ}$  li burchak mos keladi.

Unda, 2 kg tuz  $2 \cdot 30^{\circ} = 60^{\circ}$  li burchak bilan tasvirlanadi.

Aniqlangan qiymatlar asosida doiraviy diagramma quramiz. Buning uchun doira chizib, uchi doiraning markazida bo'lgan  $60^{\circ}$  li burchak bo'ylab ikkita radius o'tkzsak, hosil bo'lgan doira bo'lagi tuzning miqdorini aniqlaydi (2- rasm).

Ravshanki, doiraning qolgan bo'lagi aralashmadagi suvning miqdorini aniqlaydi.

Hosil bo'lgan shakl aralashmadagi tuz va suv miqdorini ko'rsatuvchi doiraviy diagrammadan iborat bo'ladi.

Ba'zi hollarda diagramma tuzishda butun doirani ko'proq bo'laklarga bo'lishga to'g'ri keladi.

*2- misol.* Qishloq fuqarolari yig'iniga o'tkazilgan saylovda jami 12 000 saylovchi qatnashdi. Ularning 5400 tasi *A* nomzodga, 2100 tasi *B* nomzodga, 3300 tasi *D* nomzodga, 1200 tasi *E* nomzodga ovoz berishdi.

Saylov natijalarini ko'rsatuvchi doiraviy diagramma tuzing.

*Yechish.* Butun doira (ya'ni  $360^{\circ}$ ) – barcha 12 000 ta saylovchilar sonini tasvirlasin. Unda bitta saylovchiga  $360^{\circ} : 12\ 000 = 0,03^{\circ}$  gradusli burchak

mos keladi. Endi har bir nomzodga ovoz bergan saylovchilar soniga mos kelgan burchak kattaliklarini topamiz:

$$A \text{ nomzod uchun: } 5400 \cdot 0,03 = 162^{\circ}$$

$$B \text{ nomzod uchun: } 2100 \cdot 0,03 = 63^{\circ}$$

$$D \text{ nomzod uchun: } 3300 \cdot 0,03 = 99^{\circ}$$

$$E \text{ nomzod uchun: } 1200 \cdot 0,03 = 36^{\circ}$$

Doira markazini burchaklarning uchi deb olib mos burchaklarni transportir yordamida chizsak, tegishli diagrammani hosil qilamiz (3- rasm).

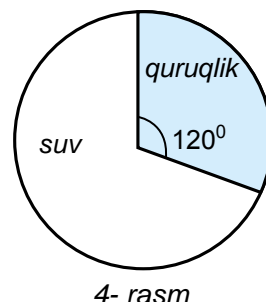
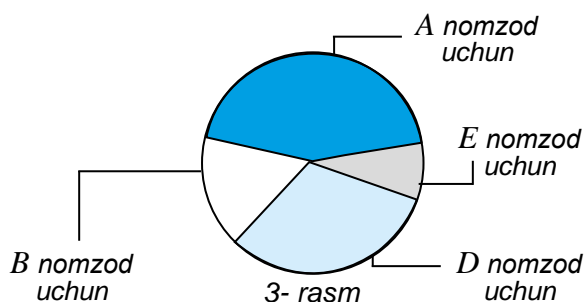

### Savollarga javob bering!



1. Doiraviy diagrammalar qanday maqsadlarni ko'zlab tuziladi?
2. Doiraviy diagrammani yasash jarayonini misolda tushuntiring.

### Sinfda bajariladigan mashqlar



**1180.** Quyidagi jadvalda dunyo okeanlarining yuzi berilgan. Undan foydalanib doiraviy diagramma quring.

Tinch okeani	Atlantika okeani	Hind okeani	Shimoliy muz okeani
180 mln km <sup>2</sup>	92 mln km <sup>2</sup>	75 mln km <sup>2</sup>	13 mln km <sup>2</sup>

**1181.** 4- rasmda Yer yuzida quruqlik va okean suvlari egallagan maydonlar diagrammasi tasvirlangan. U asosida Yer yuzining qanday qismini okean suvlari va qanday qismini quruqlik tashkil qilishini aniqlang.

**1182.** Mevadan tayyorlanadigan ichimlikning tarkibi 800 g meva, 1200 g suv va 400 g shakardan iborat. Bu ma'lumotlardan foydalanib, ichimlik tarkibini ko'rsatuvchi doiraviy diagramma quring.

**1183.** Sinf o'quvchilari o'rtasida o'tkazilgan so'rovda, 36 o'quvchining 12 tasi yashil rangni, 6 tasi qizil rangni, 8 tasi oq rangni, 4 tasi ko'k rangni, qolganlari esa sariq rangni xush ko'rishlari aniqlandi. Bu ma'lumotlardan foydalanib, so'rov natijalarini ko'rsatuvchi doiraviy diagramma tuzing.



- 1184.** Avtosalon bir oyda 20 ta «Spark», 12 ta «Lasetti», 16 ta «Neksiya», 24 ta «Kobalt» va 18 ta «Matiz» rusumidagi yengil avtomobilni aholiga sotdi. Avtosalonning oylik sotuv tarkibini ko'rsatuvchi doiraviy diagramma tuzing.
- 1185.** Quyida berilgan jadvalning bo'sh kataklarini to'ldiring va undan foydalanib Yer materiklari maydonini ko'rsatuvchi doiraviy diagramma tuzing.

Qit'alar	Maydoni (mln km <sup>2</sup> )	Mos burchak gradusi
Osiyo	43,4	
Amerika	42	
Afrika	30,3	
Antarktida	14,1	
Yevropa	11,5	
Avstraliya	8,7	
Jami		360 <sup>0</sup>



- 1186.** Quyida berilgan jadvalning bo'sh kataklarini to'ldiring va undan foydalanib Yer yuzida tarqalgan quruqlik turlari maydonini ko'rsatuvchi doiraviy diagramma tuzing.

Quruqlik turlari	Egallagan maydoni (mln km <sup>2</sup> )	Mos burchak gradusi
O'rmonlar	57	
Cho'llar	24	
Sahrolar va botqoqliklar	54	
Haydaladigan yerlar	15	
Jami		360 <sup>0</sup>

- 1187.** 5- sinf o'quvchilari o'rtasida o'tkazilgan so'rovda, 180 o'quvchining 60 tasi futbolga, 45 tasi kurashga, 15 tasi shaxmatga, 30 tasi gimnastikaga, qolganlari esa volleybolga qiziqishi aniqlandi. Bu ma'lumotlardan foydalanib, so'rov natijalarini ko'rsatuvchi doiraviy diagramma tuzing.



Uyda bajariladigan masalalar



- 1188.** Yakshanba kuni 7-, 8- va 9- sinf o'quvchilari maktab hovlisini obodonlashtirish maqsadida hasharga chiqishdi. 7-sinf o'quvchilari hovlining  $\frac{1}{6}$  qismiga, 8- sinf o'quvchilari esa  $\frac{2}{6}$  qismiga gullar ekishdi. Hovlining qolgan qismiga esa 9-sinf o'quvchilari gullar ekishdi. Bu ma'lumotlar asosida doiraviy diagramma tuzing.
- 1189.** Zavodning 1- bo'limida 270 ishchi, 2- bo'limida 360 ishchi, 3- bo'limida esa 180 ishchi ishlaydi. Bundan tashqari zavodda 90 kishidan iborat ma'muriyat xodimlari ham bor. Zavod xizmatchilari tarkibini doiraviy diagramma shaklida tasvirlang.



**1190.** Fermer xo'jaligining 22,4 ga maydondagi issiqxonasida ekinlar qancha maydonga ekilganligi doiraviy diagrammada berilgan (5-rasm). Har bir ekin ekilgan maydon kattaliklarini gektarlarda aniqlang.

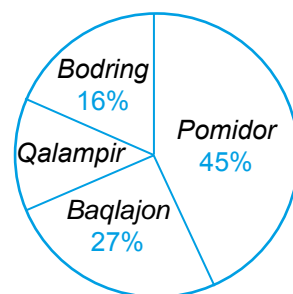

5- rasm

**1191.** So'rov natijalariga ko'ra sinfdagi 36 nafar o'quvchining 6 tasi – adabiyot, 8 tasi – matematika, 4 tasi – fizika, 3 tasi – kimyo, 7 tasi – ingliz tili, 6 tasi – informatika va 2 tasi iqtisod fani bo'yicha tashkil qilingan to'garaklarda shug'ullanishadi. Bu ma'lumotlar asosida bu sinf o'quvchilarining fan to'garaklariga qatnashishini ifodalovchi doiraviy diagramma quring.



**1192.** O'smirlar har kuni vaznining har bir kilogrammiga mos ravishda 2,5 g oqsil, 2,2 g yog' va 10,3 g uglevodlar iste'mol qilishi lozim. Vazni 40 kg bo'lgan o'quvchi har kuni qanchadan oqsil, yog' va uglevodlar iste'mol qilishini grammlarda hisoblang va doiraviy diagramma tuzing. Diagrammaga nom qo'ying.

**1193.** Olimlarning taxminiy hisob-kitoblariga qaraganda, odam o'rtacha 72 yillik umrining 30 yilini – uyquga, 12 yilini – ishga, 10 yilini – televizor ko'rish va internetdagi ijtimoiy tarmoqlarga, 6 yilini – uy ishlariga, 5 yilini – ovqatlanishga, 4 yilini – ta'lim olishga, 2 yilini – yo'lga, 3 yilini – o'ziga qarashga va qolgan umrini – boshqa ishlarga sarflayotgan ekan. Bu ma'lumotlar asosida doiraviy diagramma quring va bu ko'rsatkichlarga o'z tanqidiy fikringizni bayon qiling. Siz kundalik vaqtingizni to'g'ri taqsimlayapsizmi?

51- §.

VIII BOBNI TAKRORLASHGA DOIR MASALALAR

1194. Televizor bilan videomagnitofon birgalikda 600 000 so‘m turadi. Videomagnitofon narxi televizor narxiga qaraganda 20 foizga arzon. Televizor va videomagnitofonning narxini toping.

1195. 1-rasmdagi  $AOB$  burchakning gradus o‘lchovini toping.

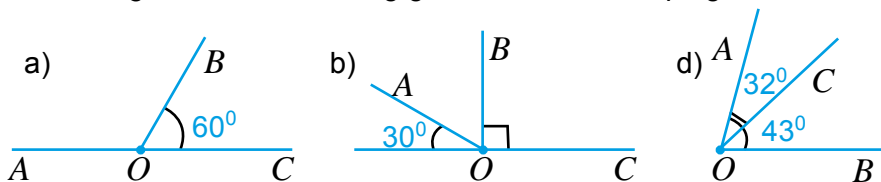

1196. Neft qayta ishlanganda, 30% – benzin, 53% – mazut olinadi. Neftning qolgan qismi esa qayta ishlash jaroyonida isrof bo‘ladi. a) necha foiz neft isrof bo‘ladi? b) 20 t neftdan qancha benzin va qancha mazut olinadi? d) 9 t benzin olish uchun qancha neftni qayta ishlash kerak?

1197  $ABF$  yoyiq burchak  $BC$  nur yordamida ikki burchakka ajratilgan.  $ABC$  burchak  $CBF$  burchakdan ikki marta katta bo‘lsa, bu burchaklarning gradus o‘lchovini toping.

1198. Fermada bir yilda bitta sigir yog‘lilik darajasi 4 % bo‘lgan 12 500 litr sut beradi. Bu sutdan qancha yog‘ ajratib olish mumkin?

1199. Korxonada xodimlarining davolanishi va dam olishiga jami 24 500 000 so‘m pul ajratildi. Bu pulning 25 foizi davolanishga ketdi. Korxonada tomonidan xodimlarning davolanishiga va dam olishiga qanchadan pul sarflandi?

1200. Avtobus 100 km masofaga 33 litr dizel yoqilg‘isi sarflaydi. Avtobusning motori tuzatilganidan keyin yoqilg‘i sarfi 10 foizga kamaydi. Avtobus motor tuzatilgandan keyin 100 km masofaga qancha yoqilg‘i sarflaydi?

1201. Sutning 10 foizi yog‘dan iborat. 215 litr sutdan qancha yog‘ olish mumkin?

1202. Likopcha piyoladan 20% arzon. Piyola likopchadan necha foiz qimmat?

1203. Ishchining oylik maoshi 300 000 so‘m bo‘lib, u dastlab 10 foizga oshdi. 6 oydan keyin yana 20 foizga oshdi. Ishchining oxirgi oylik maoshi qancha?

1204. Soatning soat mili a) 1 soatda; b) 2 soatda; d) 3 soatda; c) 4,5 soatda necha gradusga buriladi?

1205. Dam olish oromgohiga yo‘llanmaning bahosi 340 000 so‘m. Korxonada yo‘llanma bahosining 30 foizini to‘lasa, ishchi ikkita yo‘llanma uchun qancha pul to‘lashi kerak?

1206.  $\angle ABC = 64^\circ$  bo‘lib,  $BD$  – uning bissektrisasi.  $ABD$  burchakni toping.

1207. Yeryong‘oqni tozalaganda 60 foizi po‘choqqa chiqib ketadi. Narxi 2000 so‘m bo‘lgan yeryong‘oq sotib olgan yaxshimi yoki narxi 3500 so‘m bo‘lgan tozalangan yeryong‘oq sotib olgan ma‘qulmi?

1208. «DAMAS» avtomashinasi 100 km yo‘lga 6 litr benzin sarflaydi. Avtomashina 160 km yo‘l uchun qancha benzin sarflaydi?

- 1209.** Jamg'arilgan pulni omonat bankiga qo'yish mumkin. Shunda u foyda keltira boshlaydi. Agar bank yiliga qo'yilgan pulning 16 foizi miqdorida ustama foyda berishi ma'lum bo'lsa, qo'yilgan 1 000 000 so'm yil oxirida necha so'm bo'ladi? Ikki yildan keyin-chi?
- 1210.** Omonatchi jamg'arma bankiga  $a$  so'm topshirdi. Agar 1 yildan keyin omonatchining hisobida  $\frac{5a}{4}$  so'm bo'lgan bo'lsa, omonatchining puli necha foizga oshgan?
- 1211.** 1 t bug'doydan 780 kg un, 25 kg yorma, 195 kg kepak olinadi. Berilgan ma'lumotlardan foydalanib doiraviy diagramma tuzing.
- 1212.** O'quvchilarga mo'ljallangan noutbuk monitorining o'lchami 10,1 duymga teng. Monitor o'lchamini santimetrlarda ifodalang.
- 1213.** Maktablar uchun mo'ljallangan interaktiv doska monitori diagonalining o'lchami 87 duymga teng. Monitor diagonalining o'lchamini santimetrlarda ifodalang.

### Bilimingizni sinab ko'ring!



Bu bob materiallarini o'rganib chiqib, quyidagi masalalarni yecha olishingiz shart! Nazorat ishi oldidan o'zingizni sinab ko'ring!

**Test.** To'g'ri javobni aniqlang.

- O'tkir burchak gradus o'lchovi haqida nima deyish mumkin?  
**A.**  $90^0$  ga teng; || **B.**  $90^0$  dan katta; || **D.**  $90^0$  dan kichik; || **E.**  $180^0$  ga teng.
- $a$  sonining  $p$  foizi nimaga teng?  
**A.**  $p : 100$ ; || **B.**  $(a : 100) \cdot p$ ; || **D.**  $p : a$ ; || **E.**  $a : p$ .
- O'tmas, to'g'ri, yoyiq va o'tkir burchaklardan qaysi biri kichik?  
**A.** O'tmas burchak; || **B.** To'g'ri burchak; || **D.** O'tkir burchak; || **E.** Yoyiq burchak.

### 13- nazorat ishi namunasi

- Burchaklarni yasang: a)  $\angle BME = 68^0$ ; b)  $\angle CKP = 115^0$ .
- $\angle A = 120^0$  bo'lgan  $AKN$  uchburchak chizing. Uchburchakning qolgan burchaklarini o'lchang va ularning gradus o'lchovlarini yozing.
- $OK$  nur  $DOS$  to'g'ri burchakni ikki burchakka bo'ladi.  $DOK$  burchak  $DOS$  burchakning 70 foizini tashkil qiladi.  $KOS$  burchakning gradus o'lchovini toping.
- Bodring tarkibida o'rtacha 95% suv bor. 20 kg bodringda necha kilogramm suv bor?
- $DKP$  yoyiq burchakning  $KB$  bissektrisasi va  $KM$  nur o'tkazilgan. Agar  $\angle BKM = 38^0$  bo'lsa,  $DKM$  burchakni toping.

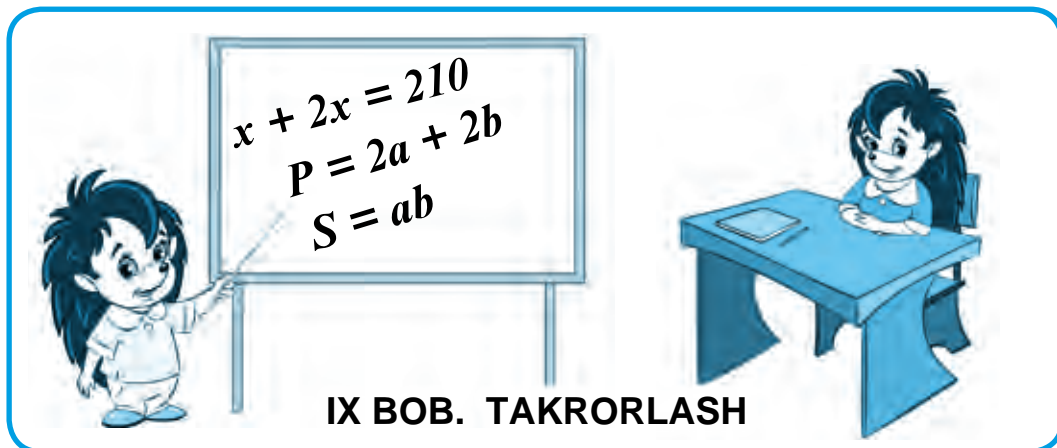

## IX BOB. TAKRORLASH

52- §.

### V SINFDA O‘TILGANLARNI TAKRORLASHGA DOIR MASALALAR

**1214.** Sonlarni taqqoslang va javobni «<» yoki «>» belgilari yordamida yozing:  
 a) 5 389 780 va 5 386 904;    b) 103 636 va 94 577.

**1215.** Sonlar nuridagi  $A, C, K, O$  nuqtalarning koordinatalarini aniqlang.



**1216.** Daftari katagi enini birlik kesma sifatida olib, sonlar nurida  $A (3), E (13), M (7), P (10)$  nuqtalarni belgilang.

**1217.** a) 31 294 sonidan 7546 ga katta bo‘lgan sonni toping.  
 b) 63 473 soni 61 625 sonidan qancha katta?  
 d) 63 473 soni 73 251 sonidan qancha kichik?

**1218.** Birinchi qopda 46 kg kartoshka bor bo‘lib, bu ikkinchi qopdagidan 15 kg kam. Ikkala qopda hammasi bo‘lib qancha kartoshka bor?

**1219.**  $DEF$  uchburchakning  $EF$  tomoni 53 sm.  $DF$  tomonidan  $EF$  tomoni 2 dm uzun,  $DE$  tomoni esa 19 sm qisqa. Uchburchak perimetrini toping va uni dm da ifodalang.

**1220.** To‘g‘ri chiziqli yo‘lak bo‘ylab 50 ta ustun o‘rnatildi. Ustunlar orasidagi masofa bir xil. Agar birinchi va oxirgi ustunlar orasidagi masofa 2450 m bo‘lsa, qo‘shni ustunlar orasidagi masofani toping.

**1221.** Ifodaning qiymatini toping:

a)  $b + d$ , bunda  $b = 40, d = 50$ ;                      b)  $450 + t - 350$ , bunda  $t = 84$ .

**1222.** Qulay usul bilan hisoblang:

a)  $3817 + 2599 + 1183$ ;                                      b)  $759 - (259 + 413)$ .

**1223.** Uzunligi 31 sm bo‘lgan  $MN$  kesmada  $D$  va  $E$  nuqtalar belgilandi. Agar  $MD = 15$  sm,  $EN = 13$  sm bo‘lsa,  $DE$  kesma uzunligini toping.

**1224.** Amallarni bajaring:

a)  $49 \cdot 176$ ; || b)  $3800 \cdot 1570$ ; || d)  $503 \cdot 705$ ; || e)  $21\,645 : 185$ ; || f)  $46\,970 : 154$ .

**1225.** Tenglamani yeching:

a)  $x \cdot 17 = 119$ ; || b)  $126 : y = 21$ ; || d)  $a : 16 = 64$ .

**1226.** Qulay usul bilan hisoblang:

a)  $25 \cdot 873 \cdot 4$ ; || b)  $125 \cdot 794 \cdot 8$ ; || d)  $20 \cdot 72 \cdot 50$ .

**1227.** Salim bir son o'yladi. Uni 5 ga ko'paytirib, ko'paytmadan 9 ni ayirdi. Natijada 71 hosil bo'ldi. Salim qanday sonni o'ylagan?

**1228.** Ifodaning qiymatini toping:

a)  $583 \cdot 479 - 483 \cdot 479$ ; || b)  $49 \cdot 68 - 7650 : 17 + 33$ ; || d)  $4^3 + 7^2$ .

**1229.** Tenglamani yeching: a)  $6y - 25 = 617$ ; || b)  $x + 7x = 104$ .

**1230.** Ifodani soddalashtiring: a)  $53t + 27 + 21t$ ; || b)  $12 \cdot c \cdot 25$ .

**1231.** Hisoblang: a)  $(4^3 + 14^2) : 13$ ; || b)  $160 \cdot 76 - 56\,650 : 55 + 9571$ .

**1232.** To'g'ri to'rtburchak shakldagi yer maydonining bo'yi 540 m, eni 250 m. Yer maydonining yuzini toping va uni ar da ifodalang.

**1233.** O'lchamlari: 4 m, 5 m va 7 dm bo'lgan to'g'ri burchakli parallelepipedning hajmini toping.

**1234.** Tezligi 120 km/soat bo'lgan tezyurar poyezdining 4 soatda bosib o'tgan yo'lini toping.

**1235.** 45 km/soat tezlik bilan 270 km suzgan teploxodning suzish vaqtini toping.

**1236.** Qirrasini 9 dm bo'lgan kub sirtining yuzi va hajmini toping.

**1237.** Sonlarni taqqoslang:

a)  $\frac{6}{17}$  va  $\frac{9}{17}$ ; || b)  $\frac{11}{14}$  va  $\frac{9}{14}$ ; || d)  $\frac{8}{7}$  va 1; || e)  $\frac{9}{10}$  va  $\frac{7}{6}$ .

**1238.** 21 ning  $\frac{3}{7}$  qismini 60 ning  $\frac{5}{6}$  qismiga qo'shing.

**1239.** a) 3 sm<sup>2</sup> kvadrat metrning qanday qismini tashkil qiladi?

b) 37 mm<sup>3</sup> kub santimetrning qanday qismini tashkil qiladi?

d) 17 kg 3 tonnaning qanday qismini tashkil qiladi?

**1240.** To'g'ri to'rtburchakning eni 42 sm bo'lib, u perimetrining  $\frac{3}{14}$  qismini tashkil qiladi. Bu to'g'ri to'rtburchakning bo'yini toping.

**1241.** Amallarni bajaring:

a)  $\frac{11}{17} - \frac{5}{17} + \frac{2}{17}$ ; || b)  $6\frac{5}{8} + 2\frac{7}{8}$ ; || d)  $8 - 4\frac{5}{7}$ ; || e)  $7\frac{4}{15} - 3\frac{11}{15}$ .

**1242.** Qutida 36 ta shar bor. Ularning  $\frac{4}{9}$  qismi oq shar. Qutida nechta oq shar bor?

**1243.** Tenglamani yeching: a)  $6\frac{7}{9} - x = 4\frac{2}{9}$ ; b)  $y + 2\frac{6}{7} = 5\frac{3}{7}$ .

- 1244.** Sonlarni taqqoslang:  
 a) 3,528 va 4,2; || b) 6,381 va 6,4; || d) 0,95 va 0,9499; || e) 54,4 va 54,04.
- 1245.** Metrda ifodalang:  
 a) 3 m 321 mm; || b) 5 m 80 mm; || d) 473 mm; || e) 5 mm.
- 1246.** Amallarni bajaring:  
 a)  $17,5 + 2,13$ ; || b)  $0,39 + 0,046$ ; || d)  $96,2 - 4,09$ ; || e)  $6 - 3,54$ .
- 1247.** Yaxlitlang:  
 a) 5,23; 20,734; 361,54 va 0,35 sonlarni birlar xonasigacha;  
 b) 0,622; 15,237; 4,3651 va 0,007 sonlarni yuzdan birlar xonasigacha.
- 1248.** Teploxodning o'z tezligi 53,2 km/soat. Teploxodning oqimga qarshi tezligi 50,5 km/soat. Teploxodning oqim bo'ylab tezligini toping.
- 1249.** Hisoblang:  
 a)  $2,45 \cdot 56$ ; || b)  $5,25 \cdot 204$ ; || d)  $342,581 \cdot 10$ ;  
 e)  $86,1 : 42$ ; || f)  $9 : 12$ ; || g)  $342,581 : 100$ .
- 1250.** Tenglamani yeching:  $5y + 6,8 = 30,3$ .
- 1251.** Ifodaning qiymatini toping:  $80 - 18,2 : 7 + 0,06$ .
- 1252.** Birinchi ko'paytuvchida vergul o'ngga 3 xona, ikkinchi ko'paytuvchida vergul chapga 1 xona surilsa, ko'paytma qanday o'zgaradi?
- 1253.** Hisoblang:  
 a)  $0,738 \cdot 9,7$ ; || b)  $3,6 \cdot 5,125$ ; || d)  $0,081 \cdot 0,1$ ;  
 e)  $28,13 : 9,7$ ; || f)  $0,0988 : 0,0095$ ; || g)  $0,052 : 0,01$ .
- 1254.** Sonlarning o'rta arifmetigini toping: 52; 38,3; 43,24; 49,6; 58,86.
- 1255.** Velosiped 12,3 km/soat tezlik bilan 4 soat, 11,7 km/soat tezlik bilan 2 soat yurdi. Velosipedning butun yo'ldagi o'rtacha tezligini toping.
- 1256.** 4 ta sonning yig'indisi 9,36 ga teng. Boshqa 7 ta sonning o'rta arifmetigi 1,9 ga teng. Barcha 11 ta sonning o'rta arifmetigini toping.
- 1257.** Taksi parkida 40 ta «Matiz» rusumli avtomobil bor. Bu jami taksilarning 16 foizini tashkil qilsa, parkda qancha avtomobil bor?
- 1258.** Tenglamani yeching:  $14 + 6,2a + 2,4a = 69,9$ .
- 1259.** Sayohatchilar avval yo'lning 60 foizini, so'ng qolgan yo'lning 20 foizini bosib o'tdi. Shundan so'ng yana 8 km yo'l qoldi. Sayohatchilar qancha yo'lni bosib o'tishgan?
- 1260.** Burchaklarni yasang: a)  $\angle CDN = 83^{\circ}$ ; b)  $\angle XOP = 120^{\circ}$ .
- 1261.** NB nur MNK to'g'ri burchakni ikki burchakka bo'ladi. KNB burchak gradus o'lchovi MNK burchak gradus o'lchovining 0,6 qismini tashkil qiladi. MNB burchak gradus o'lchovini toping.
- 1262.** BDM yoyiq burchakning DE bissektrisasi va DC nur o'tkazilgan. Agar  $\angle CDE = 19^{\circ}$  bo'lsa, BDC burchakni toping.

- 1263.** To'g'ri burchakli parallelepipedning hajmi  $13,5 \text{ sm}^3$ , eni  $4,5 \text{ sm}$ , balandligi  $4 \text{ mm}$ . Uning bo'yini toping.
- 1264.** Motorli qayiqning o'z tezligi  $12,6 \text{ km/soat}$ , daryo oqimining tezligi esa  $1,8 \text{ km/soat}$ . Qayiq oqimga qarshi  $0,5 \text{ soat}$  va oqim bo'ylab  $2,5 \text{ soat}$  suzdi. Qayiq bu vaqt ichida qancha yo'l bosgan?
- 1265.**  $BCD$  va  $DCE$  burchaklar berilgan:  $\angle BCD = 115^\circ$ ,  $\angle DCE = 32^\circ$ .  $\angle BCE$  burchakni toping.

**Bilimingizni sinab ko'ring!**



Bu bob materiallarini takrorlab, quyidagi masalalarni yecha olishingiz shart! Yakuniy nazorat ishi oldidan o'zingizni sinab ko'ring!

**Test.** To'g'ri javobni aniqlang.

1.  $132859 < 132 * 19$  tengsizlikni qanoatlantiruvchi noma'lum raqamni toping?  
**A.** 7;                      **B.** 8;                      **D.** 9;                      **E.** 6.
2. Chizmadagi  $A$  nuqtaning koordinatasi nechaga teng?



- A.** 0,5;                      **B.** 1,25;                      **D.** 0,75;                      **E.** 0,25.
3.  $ABC$  uchburchakning tomonlari  $14 \text{ sm}$ ,  $16 \text{ sm}$  va  $19 \text{ sm}$ . Uning perimetrini toping?  
**A.**  $72 \text{ sm}$ ;                      **B.**  $22 \text{ sm}$ ;                      **D.**  $49 \text{ sm}$ ;                      **E.**  $52 \text{ sm}$ .
4. Tenglamani yeching:  $y - 27 = 11 + 12$   
**A.** 50;                      **B.** 38;                      **D.** 4;                      **E.** 12.
5.  $4050 : \dots = 75$  tenglikda tushirib qoldirilgan son qaysi?  
**A.** 45;                      **B.** 33;                      **D.** 102;                      **E.** 54.
6. 3295 sonini 73 ga bo'lsa, qoldiq nima bo'ladi?  
**A.** 10;                      **B.** 27;                      **D.** 13;                      **E.** 35.
7. To'g'ri to'rtburchak yuzi  $97,5 \text{ sm}^2$ , bo'yi  $13 \text{ sm}$ . Enini toping.  
**A.**  $8,5 \text{ sm}$ ; **B.**  $9,5 \text{ sm}$ ;                      **D.**  $10,5 \text{ sm}$ ;                      **E.**  $7,5 \text{ sm}$ .
8.  $a$  ning quyidagi qiymatlaridan qaysi birida  $\frac{a}{37}$  – to'g'ri kasr bo'ladi?  
**A.** 38;                      **B.** 37;                      **D.** 36;                      **E.** 39.

### Yakuniy nazorat ishi namunasi

1. Hisoblang:  $2,66 : 3,8 - 0,81 \cdot 0,12 + 0,0372$ .
2. Do'konda 240 kg meva bor. Bir kunda uning 65 foizi sotildi. Qancha meva qoldi?
3. To'g'ri burchakli parallelepipedning hajmi  $25,2 \text{ dm}^3$ , bo'yi  $3,5 \text{ dm}$ , eni  $16 \text{ sm}$ . Uning balandligini toping.
4. Teploxodning o'z tezligi  $24,5 \text{ km/soat}$ , daryo oqimining tezligi  $1,3 \text{ km/soat}$ . Teploxod oldin  $0,4 \text{ soat ko'l bo'ylab}$ , so'ng  $3,5 \text{ soat daryo oqimiga qarshi suzdi}$ . Bu vaqt ichida teploxod qancha yo'l bosgan?
5.  $MOK$  va  $KOC$  burchaklar berilgan:  $\angle MOK = 110^\circ$ ,  $\angle KOC = 46^\circ$ .  $COM$  burchakni toping.



### Qiziqarli matematikaga oid masalalar

*www.konkurs-kenguru.ru saytida matematikadan 2010- yilgi xalqaro internet musobaqasining 5- sinf o'quvchilari uchun berilgan masalalaridan namuna:*

1. 2009- yil «Kenguru» musobaqasiga dunyo bo'yicha 5,5 million bola qatnashdi. Ularning har biri massasi 3 g bo'lgan javob varaqasini to'ldirishdi. Barcha javob varaqalarining massasini toping.
2. Jirafaning bo'yi kenguruning bo'yidan 2,4 marta baland, kenguru bo'yi esa jirafanikidan 2,52 m past. Jirafa va kenguruning bo'yini toping.
3. Quyidagi tenglikda  $\blacktriangle$  belgisi ostida qaysi raqam yashiringan?  
 $\blacktriangle + \blacktriangle + \blacktriangle + 6 = \blacktriangle + \blacktriangle + \blacktriangle + \blacktriangle + \blacktriangle + \blacktriangle$
4.  $2010 : 10 + 2010 : 201 + 2010 \cdot 0$  ifodada ikkita qavsni shunday qo'yingki, uning qiymati eng kichik bo'lsin.

*Bu saytga kirib, qolgan masalalarni ham yechib ko'ring-chi!*

*«Kenguru» xalqaro musobaqasiga sinfingiz bilan qatnashishni maslahat beramiz.*



## JAVOBLAR

- 1-§.** 2. a) 524; b) 602; d) 8 327; e) 1 923; f) 4 203; g) 6 340. 8. 3019 km. 11. 291 ta.  
6. a) 53; b) 3 441; d) 12 030 085; e) 1 000 304 060; f) 430 090 000 000;  
g) 650 500 203 007. 17. a) 157 999, 158 000, 158 001; b) 1 001 001, 1 001 000,  
1 000 999. 27. 20 202, 202 020, 2 020 202.
- 2-§.** 35. 299 t. 38. a) 2 dm 3 sm; b) 6 dm 3 sm; d) 3 dm 9 sm; e) 21 dm 4 sm.  
40. 1 100 so'm; 1 400 so'm. 41. 350 m. 49. 9 soat. 55. a) 43 sm 8 mm;  
b) 90 sm 7 mm; d) 22 sm 3 mm; e) 76 sm 8 mm. 56. 135 sm. 57. 87 mm. 58. a) 72 sm; b) 12 dm;  
d) 131 mm.
- 3-§.** 63. a) kesishmaydi; b) kesishadi; d) kesishmaydi; e) kesishmaydi; f) kesishadi;  
g) kesishadi. 66. a) 2 m 2 dm 3 sm; b) 18 m 5 dm 2 sm; d) 5 dm 9 sm; e) 37 m 8 dm 3 sm.  
69. 7 ta. 70. 2 768 m.
- 4-§.** 74. a) 4; b) 50; d) 5. 76. a) 2; A(2), B(5), C(8), D(12), E(13); b) 30; A(60), B(120),  
C(210), D(390). 88. a) A(20), B(40), C(70), D(130).
- 5-§.** 98. a) 19, 20, 21, 22, 23, 24, 25, 26; b) 2091, 2092, 2093, 2094. 101. 305.  
103. a)  $87^{***} > 86^{***}$ ; b)  $5^{****} > 8^{**}$ . 105. 123. 106. a)  $456\ 500 > 49\ 900$ ;  
b)  $36\ 106 > 36\ 099$ ; d)  $77\ 417 > 8\ 432$ ; e)  $5\ 000 < 49\ 999$ ; f)  $8\ 720\ 000 < 8\ 720\ 019$ ;  
g)  $930\ 000 < 1\ 000\ 001$ . 108. A(18); B(47). 110. 450 km. 112. a)  $8 < 10 < 23$ ;  
b)  $57 < 75 < 93$ ; d)  $42 < 65 < 87$ . 114. a)  $600\ 080 < 609\ 900$ ; b)  $43\ 006 < 43\ 007$ ;  
d)  $91\ 453 < 91\ 811$ ; e)  $80\ 000 > 79\ 999$ ; f)  $1\ 039\ 000 > 1\ 034\ 099$ ;  
g)  $5\ 000\ 009 < 5\ 000\ 010$ . 115. 4 soat. 116. 5 soat. 118. C(22); D(34).
- 6-§.** 124. 203 sm. 125. 297 dm.
- 7-§.** 137. a) 57379; b) 149038; d) 28690; e) 30826; f) 114527; g) 1104233. 138. a) 9470; b) 3007;  
d) 7842; e) 156739. 142. a) 42 193; b) 4 281 487; d) 730 243. 143. 487 t. 144. 35 063 km;  
35 335 km; 36 034 km. 149. a) 155; b) 240; d) 1050; e) 490. 151. a) 50 104; b) 91 560;  
d) 28 267; e) 42 805; f) 61 460; g) 46 193. 152. a) 1482; b) 3000; d) 1555; e) 952; f) 8824;  
g) 41 668. 154. 34 kg 250 g. 156. 1088 t; 159. a) 436; b) 1170.
- 8-§.** 165. 99 550 so'm. 169. 19 sm; 171. 355 ta. 172. a) 7642; b) 725; d) 974; e) 8001.  
173. a) 4589; b) 6770; d) 3937; e) 8850. 182. 9 sm. 185. a) 8034; b) 30 576; d) 8011;  
e) 32 024. 186. 774 m.
- 9-§.** 189. a) 97; 85; 69. b) 21; 106; 197. d) 35; 45; 135. e) 125; 15; 27. 190. a) 116;  
118; 120. b) 5; 45; 65. 195. a) 16; 4; b) 30; 414. 196. a) 13; 15; b) 26; 39; 52.  
198.  $24 - m$ ; 18; 16.
- 10-§.** 201. a)  $42 + m$ ; 45; b)  $108 + y$ ; 120. 203. a)  $22 - x$ ; b)  $80 - x$ ; d)  $y - 761$ ; e)  $z - 531$ .  
206.  $118 + x$ ; 130. 214.  $56 - x$ ; 24.
- 11-§.** 217. a) 34; b) 870; d) 824; e) 4208; f) 373; g) 1186. 219. a) 17 kg; b) 24 kg. 222. 109 t.  
232. a) 17; b) 2160; d) 91; e) 3726; f) 61; g) 1335. 240. a) 88; b) 85; d) 526; e) 1671.  
243. 22 sm.

- 12-§. 245.** 359 kg. **251.** 11sm. **263.** a) 158; b) 457; d) 102; e) 333.
- 13-§. 272.** a) 959; b) 2916; d) 2986; e) 1133. **279.** 45 sm. **282.** 72 km. **283.** 3 soat. **289.** a) 2313; b) 4329; d) 1990; e) 2790. **294.** 81 mm. **296.** 510 ta.
- 14-§. 304.** a) 4051 marta; b) 2205 marta. **313.** a) 25; b) 102; d) 808; e) 1524. **314.** a) 828; b) 3080; d) 899; e) 592. **315.** a) 8; b) 21; d) 27; e) 112. **316.** a) 43; b) 41; d) 58; e) 132; f) 360 088; g) 168 640. **320.** a) 102 marta; b) 214 marta. **326.** a) 16; b) 55; d) 213; e) 3886; f) 44 726; g) 89 713. **327.** a) 15; b) 42; d) 151; e) 45; f) 56; g) 56 291.
- 15-§. 334.** a) 781; b) 1092; d) 3718. **335.** 13 ta; 50 t. **341.** 100 g. **342.** a) 1752; b) 8218. **346.** 7 ta, 8 litr.
- 16-§. 358.** a) 1032; b) 4066. **360.** 75 sm; 120 sm. **362.** a) 1; b) 2; d) 7; e) 2. **366.** 4 kg. **368.** 25. **375.** 806 mm, 1550 mm. **378.** 420 t.
- 17-§. 390.** a)  $9a + 936$ ; b)  $41y + 1000$ . **392.** Ali – 31 kg, Vali – 30 kg, Soli – 26 kg. **398.** a) 184; b) 167; d) 1; e) 64; f) 602; g) 15 609.
- 18-§. 410.** a) 13; b) 100; d) 9; e) 7; **416.** a) 4; b) 9; d) 5; e) 1. **422.** a) 4; b) 1; d) 8; e) 3.
- 19-§. 424.** a) 5411; b) 1263; d) 8125; e) 13 672. **427.** 1047. **429.** 1046 mm. **431.** 1200 m, 125 marta. **435.** a) 42; b) 123; d) 247; e) 37 366; f) 207; g) 103. **444.** a) 4 kg; b) 5 kg.
- 20-§. 449.** a) 6 soat; b) 4 soat. **454.** 108 000 km, 1800 km. **455.** 20 dm. **459.** a) 5 km/soat; b) 40 m/s. **461.** a) 536 dm; b) 72 dm.
- 21-§. 466.** a)  $15 \text{ m}^2$ ; b)  $144 \text{ dm}^2$ ; d)  $516 \text{ sm}^2$ ; e)  $6720 \text{ dm}^2$ . **471.**  $748 \text{ sm}^2$ . **472.** a)  $108 \text{ sm}^2$ ; b)  $32 \text{ sm}^2$ ; d)  $45 \text{ sm}^2$ . **475.** a)  $15 \text{ dm}^2$ ; b)  $18 \text{ dm}^2$ . **477.** a)  $54 \text{ m}^2$ ; b)  $1056 \text{ dm}^2$ ; d)  $264 \text{ dm}^2$ ; e)  $2695 \text{ m}^2$ . **481.** a)  $140 \text{ dm}^2$ ; b)  $150 \text{ sm}^2$ ; d)  $ab - cd$ .
- 22-§. 485.** 20 ar. **490.**  $54 675 \text{ sm}^2$ . **493.** a)  $2800 \text{ m}^2$ ; b)  $2800 \text{ m}^2$ . **494.** a)  $ab : 2$ ; b)  $25 \text{ sm}^2$ ; d)  $20 \text{ sm}^2$ . **496.**  $419 528 \text{ sm}^2$ . **497.** a)  $6 \text{ sm}^2$ ; b)  $1500 \text{ sm}^2$ .
- 23-§. 503.** 296 sm. **507.**  $1428 \text{ dm}^2$ . **509.** a) 2 ta –  $2000 \text{ sm}^2$ , 2 ta –  $1500 \text{ sm}^2$ , 1 ta –  $1800 \text{ sm}^2$ . Jami:  $10800 \text{ sm}^2$ ; b) 2 ta –  $2000 \text{ sm}^2$ , 2 ta –  $1500 \text{ sm}^2$ , 1 ta –  $1200 \text{ sm}^2$ . Jami:  $8200 \text{ sm}^2$ . **515.** 2268 g. **517.** 200 sm. **521.** 104 g.
- 24-§. 523.** a)  $1440 \text{ sm}^2$ ; b)  $1944 \text{ dm}^2$ ; **526.** 11 m. **531.** 62 kg 400 g. **532.** 16 kun. **533.** a) 72 litr, b) 48 litr. **535.** a)  $320 \text{ dm}^3$ ;  $308 \text{ dm}^2$ ; b)  $534 \text{ dm}^3$ ;  $279 \text{ dm}^2$ ; d)  $156 \text{ dm}^3$ ;  $142 \text{ dm}^2$ . **541.** 195 kg. **543.** 2268 g.
- 25-§. 547.** 124 dm;  $961 \text{ dm}^2$ . **555.** 56 ar. **557.** 212 sm. **560.** 324 g. **562.** 468 kg. **564.** 19 278 g. **565.** 8000 ta.
- 26-§. 570.** a) yo'q; b) ha; d) ha.
- 27-§. 584.** a)  $\frac{114}{513}$ ; b)  $\frac{1012}{6223}$ . **585.** a)  $\frac{1}{7}$ ; b)  $\frac{3}{7}$ ; d)  $\frac{5}{7}$ . **590.** 120 bet; 200 bet. **595.** a) 95; b) 845. **596.** a)  $\frac{31}{56}$ ; b)  $\frac{112}{259}$ .
- 28-§. 603.** a)  $\frac{5}{9} > \frac{4}{9}$ ; b)  $\frac{1}{8} < \frac{7}{8}$ ; d)  $\frac{2}{5} < \frac{3}{5}$ ; e)  $\frac{2}{7} < \frac{6}{7}$ . **605.** a) 525; b) 511; d) 51. **606.**  $\frac{1}{12}$ ;  $\frac{2}{12}$ ;  $\frac{3}{12}$ ;  $\frac{4}{12}$ . **616.** 5, 6, 7, 8, 9;  $\frac{5}{13}$ ;  $\frac{6}{13}$ ;  $\frac{7}{13}$ ;  $\frac{8}{13}$ ;  $\frac{9}{13}$ .

- 29-§.** **621.** a)  $\frac{4}{7}$ ; b)  $\frac{7}{4}$ . **622.** a) 1, 2, 3, 4, 5, 6, 7, 8, 9, 10, 11, 12; b) 1, 2, 3, 4, 5, 6, 7, 8, 9, 10, 11, 12, 13, 14, 15. **623.** a) 24; b) 76; d) 36; e) 75. **630.** 10 km. **633.** a)  $\frac{4}{6}$ ; b)  $\frac{6}{4}$ . **635.**  $\frac{7}{24}$ . **637.** a) 36; b) 15.
- 30-§.** **640.**  $\frac{13}{15}$  kg. **645.** a) 5; b) 12; d) 5; e) 9. **649.** 100 kg. **651.** 20 ga. **654.** a)  $\frac{8}{34}$ ; b)  $\frac{17}{77}$ ; d)  $\frac{8}{24}$ ; e)  $\frac{66}{87}$ . **656.** 52 bet. **659.**  $\frac{11}{12}$  kg. **664.**  $\frac{14}{31}$ . **666.** a)  $\frac{25}{22}$ ; b)  $\frac{20}{47}$ ; d)  $\frac{61}{79}$ . **667.**  $\frac{2}{64}$ . **671.** 6 o'quvchi.
- 31-§.** **679.**  $\frac{2}{35}$  km. **682.**  $\frac{19}{7}$  sm. **688.**  $\frac{12}{25}$  km.
- 32-§.** **696.** a)  $3\frac{5}{6}$ ; b)  $3\frac{4}{11}$ ; d)  $3\frac{16}{35}$ ; e)  $2\frac{10}{23}$ ; f)  $1\frac{97}{126}$ . **698.**  $\frac{13}{5}$ ; **704.** 39 ta. **709.** a)  $\frac{29}{8}$ ; b)  $\frac{22}{9}$ ; d)  $\frac{317}{25}$ ; e)  $\frac{1099}{87}$ . **713.**  $18\frac{1}{8}$  ta.
- 33-§.** **725.**  $4\frac{2}{5}$ t. **731.** 20 sm. **737.**  $22\frac{2}{11}$  dm; **749.**  $11\frac{3}{8}$ t. **753.**  $29\frac{8}{10}$  dm.
- 34-§.** **754.** 39 000 kg; 1250 kg; 9750 kg. **757.** a)  $\frac{4}{6}$ ; b)  $\frac{6}{4}$ ; d)  $\frac{9}{4}$ ; e)  $\frac{4}{9}$ ; f)  $\frac{6}{9}$ ; g)  $\frac{9}{6}$ . **759.** 96 bet; 72 bet. **766.** 20 kun. **769.**  $\frac{5}{7}$ ; 25 000 kishi. **772.** a)  $\frac{15}{17}$ ; b)  $\frac{32}{71}$ ; d)  $\frac{8}{27}$ ; e)  $\frac{255}{583}$ . **777.**  $20\frac{2}{9}$  km/soat;  $14\frac{6}{9}$  km/soat. **779.**  $6\frac{3}{9}$  sm.
- 35-§.** **785.** a) 7,6; b) 7,318; d) 67,21; e) 34,3; f) 99,07; g) 3,3. **786.** a)  $3\frac{14}{100}$ ; b)  $10\frac{8}{10}$ ; d)  $443\frac{91}{100}$ ; e)  $7\frac{8}{1000}$ ; f)  $\frac{91}{100}$ ; g)  $\frac{3}{100}$ . **790.** 1. a) 5,813kg; b) 0,457kg; d) 2,307kg; e) 7,097kg; f) 1,002kg; g) 14,835 kg. **794.** a) 3,4 m; b) 0,78 m; d) 3,01 m; e) 0,017 m; f) 43,01 m; g) 0,092 m; i) 0,409 m. **795.**  $7,61\text{m}^2$ ;  $6,33\text{m}^2$ ;  $25,8\text{m}^2$ ;  $32,01\text{m}^2$ . **796.** 15 min; **797.** 668 000 so'm, 691 500 so'm, 612 000 so'm.
- 36-§.** **816.** 2 soat.
- 37-§.** **825.** SAMARQAND. **828.** a) 7,9; b) 6,04; d) 11,9; e) 3,02. **830.** a) 0,469; b) 0,1063; d) 8,515; e) 4,1204; f) 22,307; g) 56,067. **833.** 177 km. **839.** 58,12 m.
- 38-§.** **846.** a) 0,4; 1,2; 0,9; 4,1. b) 0,73; 1,19; 2,68; 11,87; d) 2,901; 0,075; 4,28; 0,909; e) 3200; 176 100; 82 400; 10 000. **850.** a) 7137578000; b) 7138000000; d) 7000000000. **852.** a) 7; b) 12; d) 0; e) 9; f) 300; g) 7. **858.** a) 2; 1; 37; 802; b) 0,4; 0,8; 1,0; 61,4. **863.** a) 1 370 711 000; b) 1 371 000 000; d) 1 000 000 000.
- 39-§.** **874.** 110,8 ming  $\text{km}^2$ ; 164,9 ming  $\text{km}^2$ . **877.** 26,5 km/soat; 16,7 km/soat. **884.** 6,566.
- 40-§.** **902.** 237,5 km; 76 km. **905.** 8276 sr. **915.** 6,3 km.
- 41-§.** **923.** a) 1000 marta; 100 marta; 10 marta, b) 1000 marta, 10 marta, 10000 marta, d) 10000 marta, 10 marta, 1000 marta. **924.** a) 1,25 kg; b) 4,2 kg. **929.** a) 72 960 fut; b) 6671,52 m. **939.** a) 0,01; b) 0,77; d) 25,7; e) 0,6. **942.** 8,4 t; 8,4 t; 11,8 t.

- 42- §. 952.** a) 0,1968; b) 0,0525; d) 46,9625; e) 0,00322; f) 3,0366; g) 6,0398; h) 3,1632; i) 0,2256; j) 2,7217. **958.**  $\approx 22,5 \text{ m}^2$ . **961.** a) 105,939 g; b) 5,925 g. **967.** 9950 kg. **969.** a) 117,6 km. b) 172,84 km; d) 697,32 km; e) 1788 km. **974.** a)  $31,8 \text{ sm}^2$ ; b)  $68 \text{ sm}^2$ ; d)  $21,36 \text{ m}^2$ ; e)  $209,95 \text{ sm}^2$ . **980.** 12880 so'm. **984.** 153 080 so'm. **988.** 375 m.
- 43- §. 998.** 120 qadam. **1002.** 4,5 qiroat. **1006.** 28,35 g. **1011.** 395 g. **1024.** 30,75 m; 154 marta. **1025.** 5 ga.
- 44- §. 1033.** 2,2 m/s. **1035.** 24 ta. **1037.** a) 75,95; b) 0,7; d) 2,225. e) 6,7. **1038.** 10,1. **1043.** 381,5 t. **1044.** 768,75 km/soat. **1047.** 5. **1051.** 64 ta. **1052.** 3. **1053.** 4,96. **1056.** 11,84.
- 45- §. 1068.** 108 375 sr. **1080.** 5 litr. **1089.** 2454,8 kg.
- 46- §. 1099.** 448 899 mln  $\text{km}^2$ . **1101.** 8,5 kg, 25,5 kg. **1107.** 30 622 058 kishi.
- 47- §. 1111.** 325 ga. **1114.**  $960 \text{ m}^2$ . **1117.** 5000 so'm. **1122.** 30%. **1128.** 75 000 ta. **1131.** 33 ta. **1135.** 3,28 kg; 5,87 kg.
- 48- §. 1146.** 15 min; 30 min. **1150.** SOR, SOP va ROP burchaklar, 3 ta bo'lakka.
- 49- §. 1160.**  $84^\circ$ . **1163.**  $41^\circ$ . **1164.** a)  $40^\circ$ . b)  $60^\circ$ . **1166.**  $78^\circ$ . **1173.**  $20^\circ$ . **1174.**  $80^\circ$ . **1176.**  $45^\circ$ .
- 50- §. 1181.** 0,7; 0,3. **1190.** Bodring – 3,584 ga, pomidor – 10,08 ga, baqlajon – 6,048 ga, qalampir – 2,688 ga.
- 51- §. 1199.** 6 125 000 so'm; 18 375 000 so'm. **1202.** 25%. **1205.** 476 000 so'm. **1208.** 9,6 litr. **1212.** 25,654 sm. **1213.** 220,98 sm.
- 52- §. 1217.** a) 38 840; b) 1848; d) 9778. **1220.** 50 m; **1223.** 3 sm. **1225.** a) 7; b) 6; d) 1024. **1229.** a) 107; b) 13. **1233.**  $14\ 000 \text{ dm}^3$ . **1238.** 59. **1239.** a) 0,0003; b) 0,037; d) 0,051. **1243.** a)  $2\frac{5}{9}$ ; b)  $2\frac{4}{7}$ . **1254.** 48,4. **1256.** 2,06; **1259.** 17 km. **1263.** 7,5 sm.

**Darslikni yaratishda foydalanilgan va ta'lim jarayonida foydalanish uchun tavsiya etilayotgan adabiyotlar va electron resurslar ro'yxati**

1. A'zamov A., B. Haydarov. Matematika sayyorasi. Toshkent. «O'qituvchi», 1993.
2. M. A. Mirzaaxmedov, A. A. Raximqoriyev, 5- sinfdan matematika, o'qituvchilar uchun qo'llanma, Toshkent, «O'zbekiston ensiklopediyasi» 2007.
3. M. A. Mirzaaxmedov, A. A. Raximqoriyev, Matematika – 5, masalalar to'plami, Toshkent, «O'zbekiston ensiklopediyasi», 2007.
4. Saitov Yo. «Matematika va matematiklar haqida». Toshkent. «O'qituvchi», 1992.
5. Yosh matematik qomusiy lug'ati. Toshkent. «O'zbekiston ensiklopediyasi», 1991.
6. Кордемский Б. А. Математическая смекалка. Москва. «Наука», 1991.
7. Максимовская М. А. Тесты по математике 5–11 классы. Москва, «Олимп», 1999.
8. Кузнецова Л. В., Сафонова Н. В. Математика 5-класс, Тематические тесты, Москва, «Просвещение», 2010.
9. Г. В. Дорофеев и др., Математика 5-класс, Дедактические материалы, Москва, «Просвещение», 2010.
10. Г. В. Дорофеев и др. Математика 5-класс, Учебник, «Просвещение», 2010.
11. Е. А. Бунимов и др., Математика 5-класс, Рабочая тетрадь, Москва, «Просвещение», 2010.
12. И. Ф. Шарыгин. Задачи на смекалку, Москва, «Просвещение», 2010.
13. Л. Г. Петерсон, И. Г. Липатникова, Устные упражнения на уроках математики 5-класс, Москва, «Школа 2000», 2008.
14. Н. Я. Великин и др. Математика 5-класс, учебник, Москва, «Мнемозина», 2008.
15. М. А. Кубышева. Сборник самостоятельных и контрольных работ, Москва, «Школа 2000», 2008.
16. Э.Р.Нурк, А.Э.Тельгмаа, Математика – 5, учебник, Москва, «Просвещение», 1992.
17. М. А. Кубышева, Математика 5, Методические материалы, Москва, «Школа 2000..», 2006.
18. Г. В. Дорофеев, Л. Г. Петерсон, Математика – 5, учебник, Москва, «Ювента», 2010.
19. Roy Edwards, Mary Edwards, Alan Ward, «Cambridge mathematics» Module 5, 1-6 Books, Cambridge University press» 1998.
20. Roy Edwards, Mary Edwards, Alan Ward, «Cambridge mathematics» Module 6, 1-6 Books, Cambridge University press» 1998.
21. Johannes Paasonen «Ahaa matematiikkaa 5», Porvoo-Helsinki-Juva, 1993.
22. Nicole Pene, Philippe Deprasle «Decimale, Math 5», Belin, Paris, 1999
23. Jennie M. Bennett and others, «Pre-Algebra» Holt, Rinehart and Winston, New York, 2004
24. <http://www.edu.uz> - Xalq ta'limi vazirligining axborot ta'lim sayti (o'zbek, rus va ingliz tillarida).
25. <http://www.uzedu.uz> - Xalq ta'limi vazirligining axborot ta'lim portali (o'zbek, rus va ingliz tillarida).
26. <http://www.eduportal.uz> - Multimedia markazi axborot ta'lim portali (o'zbek, rus va ingliz tillarida).
27. <http://www.pedagog.uz> - malaka oshirish muassasalari sayti (o'zbek va rus tillarida).
28. <http://www.math5.zn.uz> - muallifning mazkur darslik bo'yicha ochiladigan maxsus sayti (o'zbek tilida).
29. <http://www.matematika.uz> - Masofadan turib o'qitish sayti (uzbek tilida).
30. <http://www.cde.sakha.ru> - Masofadan turib o'qitish sayti (rus tilida).
31. <http://www.iro.sakha.ru> - Ta'limni rivojlantirish instituti sayti (rus tilida).
32. <http://www.school.edu.ru> - Umumta'lim portali (rus tilida).
33. <http://www.allbest.ru> - Internet resurslari electron kutubxonasi (rus tilida).
34. <http://matematika.mgtdt.ru/> - Matematikadan va informatikadan sirtqi tanlov (rus tilida).
35. <http://www.mathtype.narod.ru/> - Online-darsliklar (rus tilida).
36. <http://mschool.kubsu.ru/> - Elektron qo'llanmalar kutubxonasi. Sirtqi matematik olimpiadalar.
37. <http://matematika.agava.ru/> - Matematikadan 2000 dan ortiq masalalar (rus tilida).
38. <http://mat-game.narod.ru/> - Matematik gimnastika. Matematik masalalar va boshqotirmalar.
39. <http://mathc.chat.ru/> - Matematik kaleydoskop (rus tilida).
40. <http://mathmag.spbu.ru/> - Internetdagi matematika jurnali (rus tilida).
41. <http://www.matematik1.narod.ru/> - Matematikadan masalalar (rus tilida).
42. <http://www.problems.ru/> Matematikadan masalalar izlash tizimi (rus tilida).

43. <http://geometry.net/> - Algebra va geometriyadan o'quv materiallari (ingliz tilida).
44. <http://mathproblem.narod.ru/> - Matematik to'garaklar, maktablar va olimpiadalar (rus tilida);  
<http://www.pdmi.ras.ru/~olymp/> - Matematikadan olimpiada masalalari (rus tilida).
45. <http://mathtest.narod.ru/> - Matematik testlar (rus tilida).
46. <http://www.ams.org/mathweb/> - Internetda matematika (ingliz tilida).
47. <http://slovo.and.ru/z-index.htm> - Masalalar to'plami (rus tilida).
48. <http://www.sch57.msk.ru/collect/smogl.htm> - Matematika tarixiga doir sayt (rus tilida).
49. <http://www.mccme.ru/free-books/> - Matematikadan masalalar to'plami, ma'ruzalar, kitoblar (rus tilida).
50. <http://www.ixl.com> - Masofadan turib o'qitish sayti (ingliz tilida).
51. <http://www.konkurs-kenguru.ru> - Masofaviy matematik musobaqa sayti (rus tilida).
52. <http://www.cobo.uz> - Matematikadan tanlov (uzbek tilida).

**BAHODIR HAYDAROV**

**«MATEMATIKA»**

Umumiy oʻrta taʼlim maktablarining 5-sinfi uchun darslik

Toshkent — «Yangiyoʻl poligraf servis» — 2015

Muharrir — *J. Azimov*

Musahhih — *M. Riksiyeva*

Texnik muharrir — *M. Riksiyev*

Original-maketdan bosishga ruxsat etildi 25. 06. 2015.

Bichimi 70x100<sup>1</sup>/<sub>16</sub>. «Arial» garniturası. Ofset bosma usulda bosildi.  
Shartli bosma tabogʻi 17,55. Nashr bosma tabogʻi 15,0. Nusxasi  
Buyurtma N

Shartnoma N\_\_\_\_\_.

«Yangiyoʻl poligraf servis» MCHJ bosmaxonasida bosildi.  
Toshkent viloyati, Yangiyoʻl tumani, Samarqand koʻchasi, 44.

**Ijaraga berilgan darslik holatini ko'rsatuvchi jadval**

T/r	O'quvchining ismi va familiyasi	O'quv yili	Darslikning olingandagi holati	Sinf rahbarining imzosi	Darslikning topshirilgandagi holati	Sinf rahbarining imzosi
1						
2						
3						
4						
5						
6						

**Darslik ijaraga berilib, o'quv yili yakunida qaytarib olinganda yuqoridagi jadval sinf rahbari tomonidan quyidagi baholash mezonlariga asosan to'ldiriladi:**

Yangi	Darslikning birinchi marotaba foydalanishga berilgandagi holati.
Yaxshi	Muqova butun, darslikning asosiy qismidan ajralmagan. Barcha varaqlari mavjud, yirtilmagan, ko'chmagan, betlarida yozuv va chiziqlar yo'q.
Qoniqarli	Muqova ezilgan, birmuncha chizilib, chetlari yedirilgan, darslikning asosiy qismidan ajralish holati bor, foydalanuvchi tomonidan qoniqarli ta'mirlangan. Ko'chgan varaqlari qayta ta'mirlangan, ayrim betlariga chizilgan.
Qoniqarsiz	Muqovaga chizilgan, yirtilgan, asosiy qismdan ajralgan yoki butunlay yo'q, qoniqarsiz ta'mirlangan. Betlari yirtilgan, varaqlari yetishmaydi, chizib, bo'yab tashlangan. Darslikni tiklab bo'lmaydi.