

B. Q. HAYDAROV

MATEMATIKA 5

Uluwma worta bilim beriw mekteplerinin'
5-klasi' ushi'n sabaqli'q

Qayta islengen ha'm toliqtirilg'an yekinshi baspasi

*O'zbekistan Respublikasi' Xali'q bilimlendiriw
ministrligi tasti'yi'qlag'an*

TASHKENT
«YANGIYO'L POLIGRAF SERVIS»
2015

UO'K: 372.851(075)

KBK 22.1(50')

H 19

Haydarov B. Q.

Matematika: 5 sinf : Uli'wma worta bilim beriw mekteplerinin' 5-klasi' ushi'n sabaqli'q.- T.: "Yangiyo'l poligraf servis" 2015. – 240 b.

ISBN 978-9943-979-12-3

UO'K: 372.851(075)

KBK 22.1(50')ya72

Pikir bildiriwshiler – **Sh. A. Alimov** – fizika- matematika pa'nlerinin' doktori', professor;

M. M. Tlewmuratov – Xali'q bilimlendiriw ag'lasi', Xojeli rayoni' 70-mekteptin' joqari' kategoriyali' matematika woqi'ti'wshi'si';

M. M. Shoniyozoha'm – Tashkent qalasi' 300-mektep woqi'ti'wshi'si';











I. V. Chernyakoha'm – Tashkent qalasi' 2-mektep woqi'ti'wshi'si'.

A'ziz woqi'wshi'!

Siz bul woqi'w ji'li'nda da matematika menen tani'si'wdi' dawam yetesiz. Matematika mi'n' ji'llar dawami'nda insan talaplari'ni'n' wo'nimi si'pati'nda payda bolg'an. Woni'n' rawajlani'wi'na ulli' babami'z – shi'g'i'sti'n' belgili dani'shpanlari', ulli' matematik ali'mlari' u'lken u'les qosqan. Bu'gingi ku'nde hesh bir adam matematikani' bilmey turi'p, wo'z turmi'si'n toli'q ko'z aldi'na keltire almaydi'. Matematika sizge tek yesap-sanaq islerin u'yretip qoymastan, yen' tiykarg'i'si' – sizdi logikali'q pikirlewge, turmi'sli'q mashqalalardi'n' yen' unamli' sheshimin tabi'wg'a ja'rdem beredi.

Qoli'n'i'zdagi' bul sabaqli'q iygilikli maqsetlerin'izdi a'melge asi'wi'nda sizge g'amxorli'q yetedi, biyminnet ja'rdemshi boladi' ha'm woni'n' betlerinen tek matematikag'a tiyisli mag'li'wmatlar menen yemes, al texnika pa'n tariyxi', do'gerek-a'tirap ha'm ku'ndelikli turmi'sqa tiyisli qi'ziqli' ha'm paydali' mag'li'wmatlar menen de tani'sasi'z. Bul mag'li'wmatlar ha'r tu'rli ma'sele ha'm mi'sallar ko'rinisinde itibari'n'i'zg'a usi'ni'lmaqta.

Sabaqli'q betlerinde teoriyali'q mag'li'wmatlar, qag'i'yda, ma'sele ha'm tapsi'rmalar to'mendegi belgiler asti'nda berilgen:

- | | |
|--|---|
|  – Eslep qali'w kerek bolg'an teoriyali'q mag'li'wmat ha'm tu'si'nikler; |  – Aktivlestiriwshi shi'ni'g'i'wlar; |
|  – Wo'zlestirilgen bilimlerde baqlawg'a ali'wg'a tiyisli tapsi'rmalar; |  – Klasta wori'nlanatug'i'n shi'ni'g'i'wlar; |
|  33. – Awi'zeki wori'nlanatug'i'n shi'ni'g'i'wlar; |  – U'yde wori'nlanatug'i'n shi'ni'g'i'wlar; |
|  11. – Wo'tilgenlerde ta'kirarlaw ushi'n berilgen shi'ni'g'i'wlar; | 38. – Jaqsi' wo'zlestiriwshi woqi'wshi'lar ushi'n arnalg'an shi'ni'g'i'wlar; |
|  22. – Wo'tilgenlerde aw'szeki ta'kirarlaw ushi'n berilgen shi'ni'g'i'wlar; |  – Matematika tariyxi'na tiyisli u'zindiler ha'm tapsi'rmalar; |
|  – Bir sabaqqa aji'rati'lg'an shi'ni'g'i'wlar-di' bir-birinen aji'rati'wshi' belgi; |  – Qi'ziqli' matematikag'a tiyisli ma'seleler. |

Respublika maqsetli kitap jamg'armasi' yesabi'nan ijara ushi'n basi'p shi'g'ari'ldi'.

© B. Q. Haydarov, 2011, 2015.

© «Yangiyo'l poligraf servis», 2011, 2015

ISBN 978-9943-979-12-3

M A Z M U N I

I bap. Natural sanlar ha'm shkalalar

1. Natural san tu'sinigi. Natural sanlardin' jazili'wi' ha'm woqi'li'wi'	5
2. Kesindi. Kesindinin' uzi'nli'gi'. U'shmu'yeshlik	11
3. Tegislik, tuwri' si'zi'q ha'm nur	17
4. Shkalalar ha'm koordinatalar. San nuri'	20
5. Natural sanlardi' salisti'ri'w. U'lken ha'm kishi.....	28
6. I bap'ti' ta'kirarlawg'a tiyisli ma'seleler	32

II bap. Natural sanlardi' qosi'w ha'm ali'w

7. Natural sanlardi' qosiw ha'm wolardin' qasiyetleri.....	36
8. Natural sanlardi' ali'w ha'm woni'n' qasiyetleri.....	41
9. Sanli' ha'm ha'ripli an'latpalar	46
10. Qosi'w ha'm ali'wdi'n' qasiyetlerinin' ha'ripli an'latpasi'.....	48
11. Ten'lemeler.....	51
12. II bap'ti' ta'kirarlawg'a tiyisli ma'seleler	57

III bap. Natural sanlardi' ko'beytiw ha'm bo'liw

13. Natural sanlardi' ko'beytiw ha'm woni'n' qasiyetleri.....	62
14. Natural sanlardi' bo'liw.....	67
15. Qaldiqli' bo'liw	72
16. An'latpalardi' a'piwayi'lasti'ri'w.....	75
17. Natural sanlar u'stinde to'rt a'melge tiyisli ma'seleler sheshiw. A'mellerdi wori'nlaw ta'rtibi.	81
18. Sanni'n' da'rejesi. Sanni'n' kva'drati' ha'm kubi'	85
19. III bap'ti' ta'kirarlawg'a tiyisli ma'seleler	88

IV bap. Maydan ha'm ko'lem

20. Formulalar	92
21. Maydan. Tuwri'mu'yeshlik ha'm kva'drat maydani'ni'n' formulalari'.....	95
22. Maydan wo'lshem birlikleri.....	100
23. Tuwri'mu'yeshli paralelepiped ha'm kub.....	103
24. Ko'lem. Ko'lemnin' wo'lshem birlikleri. Tuwri' mu'yeshli paralelepipedtin' ko'lemi	108
25. IV bap'ti' ta'kirarlawg'a tiyisli ma'seleler	114

V bap. A'piwayi' bo'lshekler

26. Shen'ber ha'm do'n'gelek	117
27. U'lesler. A'piwayi' bo'lshekler haqqi'nda tu'sinik.....	119
28. Bo'lsheklerdi salisti'ri'w	124
29. Duri's ha'm naduri's bo'lshekler	128
30. Bo'limleri birdey bolgan bo'lsheklerdi qosi'w ha'm ali'w	131
31. Bo'liw ha'm bo'lshekler	136
32. Aralas sanlar.....	139
33. Aralas sanlardi' qosi'w ha'm ali'w	144
34. V bap'ti' ta'kirarlawg'a tiyisli ma'seleler	151

VI bap. Wonli'q bo'lshekler

35. Wonli'q bo'lsheklerdin' jazi'li'wi' ha'm woqi'li'wi'	155
36. Wonli'q bo'lsheklerdi sali'sti'ri'w.....	160
37. Wonli'q bo'lsheklerdi qosi'w ha'm ali'w	165
38. Sanni'n' juwi'q ma'nisi. Sanlardi' do'n'geleklew	170
39. VI bap'ti' ta'kirarlawg'a tiyisli ma'seleler	175

VII bap. Wonli'q bo'lsheklerdi ko'beytiw ha'm bo'liw

40. Wonli'q bo'lsheklerdi natural sang'a ko'beytiw	178
41. Wonli'q bo'lsheklerdi natural sang'a bo'liw	183
42. Wonli'q bo'lsheklerdi ko'beytiw	190
43. Wonli'q bo'lshekke bo'liw.....	196
44. Arifmetikali'q wortasha.....	201
45. VII bap'ti' ta'kirarlawg'a tiyisli ma'seleler	204

VIII bap. Procentler

46. Procent haqqi'nda tu'sinik.....	208
47. Procentlerge tiyisli ma'seleler sheshiw	212
48. Mu'yesh. Tuwri' ha'm jayi'q mu'yesh	217
49. Mu'yeshlerdi wo'lshew. Transportir	222
50. Do'n'gelek diagrammalar ha'm wolardi' jasaw.....	226
51. VIII bap'ti' ta'kirarlawg'a tiyisli ma'seleler	230

IX bap. Ta'kirarlaw

52. V klasta wo'tilgenlerdi ta'kirarlawg'a tiyisli ma'seleler.....	232
Juwaplar	237

Sabaqli'q sayti'na xosh kelipsiz!

«Matematika 5» sabaqli'g'i'n ja'ne de jetilistiriw ha'm wog'an tiyisli woqi'w-metodikali'q materiallard'i jarati'w ha'm bayi'ti'p bari'w maqsetinde avtor ta'repinen arnawli' sayt jarati'ldi'. Saytti'n' «ZiyoNet» tarmag'i'ndag'i' elektron ma'nzili – matematika5.zn.uz. Keleshekke bul sayt bilim jan'ali'qlari', woqi'w-normativ hu'jjetler, qosi'msha teoriyali'q ha'm woqi'w-metodikali'q materiallar, klastan ti'sqari' shi'ni'g'i'wlar (do'gerek, olimpiada) materiallari', matematika pa'ni tariyxi'na tiyisli u'zindiler ha'mde qi'zi'qli' ma'seleler g'a'ziyinesine aylandi'ri'ladi' ha'm wog'an wo'z materiallari'n'i'zdi' da qosi'wi'n'i'z mu'mkin. Sayt ja'rdeminde sabaqli'qtin'qolayli'qlari' ha'm kemshilikleri haqqi'nda pikir ha'm usi'ni'slari'n'i'zdi' ka'siplesleslerin'iz benen wortaqlsi'wi'n'i'z mu'mkin. Sonday-aq, usi' sabaqli'q tiykari'nda sabaq beriw dawami'nda payda bolg'an sawallarg'a avtordi'n' wo'zinen juwap ali'wi'n'i'z mu'mkin.

Avtor sabaqli'q ha'm sayt haqqi'ndag'i' barli'q pikir ha'm usi'ni'slari'n'i'zdi' te-ren' minnetdarshi'li'q penen ku'tip qaladi' ha'm wolardi' avtordi'n' elektron ma'nzili khaydarov@ yahoo.com jiberiwin'iz de mu'mkin.

1 2 3

4 5 6

7 8 9



I II III

IV V VI

VII VIII IX



I BAP. NATURAL SANLAR HA'M SHKALALAR

1- §.

NATURAL SAN TU'SI'NI'GI'.

NATURAL SANLARDI'N' JAZI'LI'WI' HA'M WOQI'LI'WI'

1.1. Natural sanlar qatari'

To'mendegi su'wrette yeki alma, u'sh dapter ha'm wo'n kitap su'wretle-
ng'en. Sanlardan paydalanip usi' na'rselerdi to'mendegishe jazi'w mu'mkin:



2 alma,

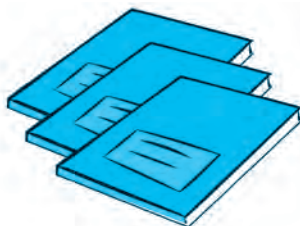

3 da'pter,



10 kitap.

Zatlardi' sanawda qollani'latug'i'n sanlar *natural sanlar* deb ataladi.

Joqari'dagi' ko'rilgen mi'salda 2, 3 ha'm 10 sanlari' natural sanlar.

Ha'r qanday natural san won 1,2,3,4,5,6,7,8,9,0 cifrlari' menen an'lati'ladi'.

Sanni'n' tek g'ana 0 den 9 g'a deyin bolg'an cifrlar menen usi'nday
jazi'li'wi'na *sanni'n' wonli'q jazi'li'wi' delinedi*. Wol halda san *wonli'q sanaq
sistmasi'nda* jazi'lg'an dep te ayti'ladi'.

1 den baslap barli'q natural sanlardi' izbe-iz jazi'p shi'qsaq,

1, 2, 3, 4, 5, 6, 7, 8, 9, 10, 11, 12, 13, 14, 15, 16, 17, ...
ko'rinishidagi *natural sanlar qatari'n* payda yetemiz.

Natural sanlar qatari'nda 1 yen' kishi natural san.



Ha'r qanday natural sang'a 1 di qossaq, natural sanlar qatari'nda wonnan
keyin turi'wshi' keyingi natural san payda boladi'. Soni'n' ushi'n natural
sanlar qatari'nda yen' u'lken san joq. Sebebi, yen' u'lken san bar desek,
wog'an 1 di qosi'p wonnanda u'lken san payda yete beremiz.

Natural sanlar qatari' sheksiz.



Sannin' wonliq jazi'li'wi'nda ha'r bir sannin' ma'nisi woni'n' turg'an worni'na baylani'sli' boladi'. Yeger 7 sani' natural san jazi'wi'ni'n' yen' aqiri'nda turg'an bolsa, 7 birlikti, aqiri'nan yekinni' wo'rinda turg'an bolsa, 7 wonliqti, aqiri'nan u'shinshi wori'nda turg'an bo'lsa, 7 ju'zlikti an'latadi' ha'm t.b.

Mi'sali', 7 sani' 127 jazi'wi'nda – 7 birlikti, 472 jazi'wi'nda – 7 wonli'qti', 780 jazi'wi'nda – 7 ju'zlikti an'latadi'.

0 cifri wo'zi turg'an qanada birde birlik joq yekenligin bildiredi. Bul belgi nol sani'n an'lati'wda da paydalani'ladi'.



0 natural san yemes.

1.2. Ko'p qanali' sanlar, wolardi'n' woqi'li'wi' ha'm jazi'li'wi'

Natural sannin' jazi'li'wi' bir belgiden (cifrdan) ibarat bolsa, bul san – *bir qanali'*, yeki belgiden (cifrdan) ibarat bolsa, *yeki qanali' san* dep ataladi'. Usi'g'an uqsas, natural sanlar jazi'wi'ndagi' belgiler (cifrlardi'n') sani'na qarap, u'sh qanali', to'rt qanali', bes qanali' h.t.b. qanali' sanlar haqqi'nda ayti'w mu'mkin.

Ma'selen, 1, 3, 6, 9 – bir qanali', 19, 22, 87 – yeki qanali', 307, 976 – u'sh qanali', 6717, 4500 – to'rt qanali', 20 456, 56 001 – bes qanali' sanlar.

Yeki ha'm wonnan ko'p qanali' sanlar – *ko'p qanali' sanlar* dep ataladi'.

Ko'p qanali' sanlardi' woqi'w ushi'n wolar won' ta'repten baslap u'sh cifrdan ibarat toparlarga aji'rati'ladi' (yen' aqir'gi' topar bir yamasa yeki cifrdan ibarat bo'li'wi' da mu'mkin). Bul toparlar *klasslar* dep ataladi'.

Won' ta'reptegi birinshi u'sh cifr *birlikler klasi'n*, keyingi u'sh cifr *mi'n'li'qlar klasi'n* quraydi' ha'm wolardan keyin *millionlar*, *milliardlar* ha'm basqa klasslar keledi.

1 000 000 – million sani'ni'n' jazi'li'wi' ha'm wol qi'sqasha 1 mln dep te jazi'ladi'. *Millionlar klasi'* – *millionlar*, *won millionlar* ha'm *ju'z millionlar xanasi'nan* payda bolg'an. Wolardi' millionlar klasi'ni'n' birlikler, wonli'qlar ha'm ju'zlikler qanasi' dep te ataymi'z. Ko'rinip turg'ani'nday, 1 million 1000 mi'n'g'a ten' boladi'

1 000 000 000 – milliard sani'ni'n' jazi'li'wi' ha'm wol qi'sqasha 1 mlrd dep te jazi'ladi'. 1 milliard 1000 million'g'a ten'.

1-mi'sal. Aytayi'q 29 405 378 613 sani' wonli'q jazi'w kestesinde jazi'lg'an bolsi'n.

Kesteden ko'rinip turg'anday, berilgen sannin' milliardlar klasi'nda 29 birlik, millionlar klasi'nda 405 birlik, mi'n'li'qlar klasi'nda 378 birlik ha'm sonday-aq birlikler klasi'nda 613 birlik bar.

Klasslar ati'	milliardlar			millionlar			mi'n'li'qlar			birlikler		
	ju'zlikler	wonli'qlar	birlikler	ju'zlikler	wonli'qlar	birlikler	ju'zlikler	wonli'qlar	birlikler	ju'zlikler	wonli'qlar	birlikler
San		2	9	4	0	5	3	7	8	6	1	3
Woqi'li'wi':	29 milliard			405 million			378 mi'n'			613		

Sandi' woqi'w ushi'n shepten won'g'a qarap sanni'n' ha'r bir klasi'ndagi' birlikler sani'na usi' klass ati'n qosi'p izbe-iz ayti'p shi'g'i'ladi'. Yen' aqi'rg'i' birlikler klasi'ni'n' ati' woqi'lmaydi'. Yeger klassti'n' ha'r u'sh xanasi'nda 0 turg'an bolsa, bul klassti'n' ati' da woqi'lmaydi'.



29 405 378 613 sani' – 2 won milliard, 9 bir milliard, 4 ju'z million, 5 bir million, 3 ju'z mi'n', 7 won mi'n', 8 bir mi'n', 6 ju'z, 1 won, 3 birden ibarat.

2-mi'sal. Wonli'q jazi'w kestesine jazi'lg'an 247 108 000 394 sanni'n' mi'n'li'qlar klasi' tek nollerden ibarat.

Soni'n' ushi'n sandi' woqi'wda bul klass ati' woqi'lmaydi'.

Klasslar ati'	milliardlar			millionlar			mi'n'li'qlar			birlikler		
Klass qanalari'ni'n' ati'	ju'zlikler	wonli'qlar	birlikler	ju'zlikler	wonli'qlar	birlikler	ju'zlikler	wonli'qlar	birlikler	ju'zlikler	wonli'qlar	birlikler
San	2	4	7	1	0	8	0	0	0	3	9	4
Woqi'li'wi':	247 milliard			108 million						394		

Sanlar wonli'q jazi'w kestden paydalanbastan woqi'lg'anda to'mendegishe jol tuti'ladi':

Berilgen san aldi'n toparlarga' aji'rati'ladi' ha'm toparlar arasi'nda biraz wori'n qaldi'ri'p, qayta jazi'p shi'g'i'ladi'. Son' joqari'dagi' qag'i'ydag'a muwapi'q woqi'ladi'.

3-mi'sal. 373612400026 sani' berilgen bolsa, aldi'n wol 373 612 400 026 ko'riniside qayta jazi'li'p, klasslarga' aji'rati'ladi' ha'm u'sh ju'z jetpis u'sh milliard alti' ju'z won yeki million to'rt ju'z mi'n' jigirma alti' dep woqi'ladi'.

4-mi'sal. Yendi won yeki milliard alti' ju'z seksen tog'i'z mi'n' yeki sani'n cifrlar menen jazayi'q. Buni'n' ushi'n da wonli'q jazi'w kestesinen paydalana-mi'z.

Shepten won'g'a qaray milliardlar klasi'na 12 ni, millionlar klasi'na 000 di, mi'n'li'qlar klasi'na 689 di', birlikler klasi'na bolsa 002 ni jazami'z. Bunda, millionlar klasi'ni'n' ati' woqi'lg'an bolsa da, wog'an u'sh 0 di jazdi'q. Sog'an uqsas birlikler klasi'ndagi' ju'zlikler ha'm wonli'qlar xanasi'ni'n' atlari' woqi'lmag'an bolsada, bul qanalarga' da 0 di jazip qoydi'q.

Na'tiyjede, 12 000 689 002 jazi'wi' payda boldi'.

Sorawlarg'a juwap berin'!



1. Sanlardi' jazi'wda neshe cifr qollani'ladi' ha'm wolardi' ayti'n'.
2. Qanday sanlar natural sanlar dep ataladi'?
3. Ko'p qanali' sanlar qanday tu'rde klaslarga' aji'rati'ladi'?
4. Ko'p qanali' sanlar qanday tu'rde klaslarga' aji'rati'ladi'?
5. Qanday klass atlari'n bilesiz?
6. Ko'p qanali' sanlar qalay woqi'ladi'?



Klasta wori'nlanatug'i'n shi'ni'g'i'wlar

1. a) 999 sani'nan keyin keliwshi; b) 100 sani'nan aldi'n keliwshi; d) 13 400 sani'nan aldi'n keliwshi; e) 90 999 sani'nan keyin keliwshi; f) 8 000 sani'nan birge kem; g) 3 299 999 sani'nan birge arti'q bolg'an natural sandi' aytin'.
2. Sanlardi' wonli'q jazi'w kestesine jaylasti'ri'n' ha'm woqi'n':

a) 5 ju'z 2 won 4 bir;	b) 6 ju'z 0 won 2 bir;
d) 8 mi'n' 3 ju'z 2 won 7 bir;	e) 3 bir 2 won 9 ju'z 1 mi'n';
f) 2 ju'z 3 bir 4 mi'n' 0 won;	g) 4 won 6 mi'n' 0 bir 3 ju'z.
3. Sanlardi wo'nliq kestesine jaylasti'ri'n' ha'm wo'qin':

a) 2 402 358;	b) 412 000 627;	d) 102 812 443;	e) 252 700 824 301;
f) 412 000 627;	g) 24 000 003;	h) 123 240 000;	i) 908 100 006 721.

U'lg'i: Joqari'da ko'rilgen 1-, 2-, 3-mi'sallar.
4. Sanlardi' woqi'n'.

mlrd	mln	mi'n'	bir
a) 234	509	234	179;
b)	490	324	800;
d) 3	392	000	671;
e)	234	000	999 000.



5. Sanlardi' klassslarg'a aji'rati'p jazi'n' ha'm woqi'n':

a) 24308512604;	b) 103492001320;	d) 600210334000;	e) 191000054407.
-----------------	------------------	------------------	------------------

U'lg'i: Joqari'da ko'rilgen 3-mi'sal.
6. To'rt xanali', bes xanali' ha'm alti' xanali' sanlardi' so'z benen qag'azg'a jazi'n' ha'm woni' qasi'n'izda woti'rg'an klaslasi'n'iz benen almasti'ri'n'. So'z benen jazi'lg'an canlardi' cifrlar menen jazi'n' ha'm qag'azdi' klaslasi'n'izg'a qaytari'n'. Klaslasi'n'iz tapsi'rmani' qalay wori'nlag'ani'n tekserin'.
7. A'mellerdi wori'nlaw ta'rtibin ayti'n' ha'm awi'zeki yesaplan':

a) $3420 - 40 : 2$;	b) $(4532 + 8) : (99\ 998 - 99\ 997)$;
d) $200 \cdot 10 : 5$;	e) $(200 - 199) \cdot (400 + 1200 : 2)$.
8. A'muwda'ryani'n' uzi'nli'g'i' 2540 km. Si'rda'rya wog'an qarag'anda 479 kmge uzi'n. Sirdaryani'n' uzi'nli'g'i'n tabi'n'.
9. Nurali'y shopanda 123, Sherali'y shopanda bolsa wonnan 45 ke ko'p qoy bar. Yeki shopanda ja'mi neshe qoy bar?
10. Tsifrlar menen jazi'n':

a) 453 mi'n';	b) 23 mln;	d) 102 mlrd;	e) 12 mlrd 203 mln 2 mi'n'.
---------------	------------	--------------	-----------------------------
11. Sanlardi' wonliq kestesinen paydalani'p cifrlar menen jazi'n':

a) yeliw u'sh;	b) u'sh mi'n' to'rt ju'z qi'rq bir;	d) won yeki million wo'ti'z mi'n' sek-sen bes;	e) bir milliard u'sh ju'z to'rt mi'n' alpi's;	f) to'rt ju'z woti'z milliard toqsan million;	g) alti' ju'z yeliw milliard bes ju'z million yeki ju'z u'sh mi'n' jeti.
----------------	-------------------------------------	--	---	---	--





22. Qaladan Abat awi'li'na shekemgi jol 23 km boli'p, wol Azad awi'li'na shekemgi joldan 4 km uzi'n. Qaladan Azad awi'li'na shekemgi jol neshe km?

23. 517 sani'n izbe-iz a) 2 ma'rte; b) 3 ma'rte; d) 4 ma'rte jazi'n'. Payda bolg'an sanlardi' woqi'n' ha'm so'zler menen jazi'n'.

24. Sanlardi' cifrlar menen jazi'n': a) won u'sh mi'n' alti' ju'z alpi's yeki'; b) jigirma u'sh million jetpis yeki' mi'n' wotiz to'rt; d) yeki milliard besh ju'z u'sh mi'n' alpi's bir; e) jети ju'z seksen milliard to'rt ju'z million bir ju'z jети mi'n' alti.

25. a) 12 312 123; b) 33 333 333; d) 202 042 004 sani' neshe xanali' ha'm wol neshe belgi menen jazi'lg'an? Jazi'wda neshe tu'rli cifr qollani'lg'an?

26. 531 020, 2 140 530, 909 444 129 008, 2 850 003, 73 302 100, 12 326 751 074, 93 405 002 sanlardi' so'zler menen jazi'n' ha'm wolardi'n' neshe xanali' yekenligin ayti'n'.

27. 20, 202, 2020, ... sanlar izbe-izligi qanday ni'zam tiykari'nda jazi'lg'an? Woni'n' keyingi u'sh ag'zasi'n jazi'n' ha'm woqi'n'.



Matematika tariyxi'na tiyisli u'zindiler

Ha'zirde du'nyada ken' tarqalg'an: 1, 2, 3, 4, 5, 6, 7, 8, 9, 0 cifrlari' "arab cifrlari'" dep atalsa da, negizinde wolardi'n' kelip shi'g'i'wi' hindlerge bari'p taqaladi'.

Ga'p sonda, bul cifrlardi' arablar hindlerden wo'zlestirgen. 1120-ji'lg'a kelip ingliz filosofi' Adelard ulli' babami'z Al-Xorazmiydin' arab tilinde jazi'lg'an kestelerin ingliz tiline awdarg'an. Sonnan berli, bul cifrlar Yevropada "arab cifrlari'" dep paydalani'la baslang'an. 1600-ji'lg'a kelip bolsa, bul cifrlar du'nyani'n' ko'plegen ma'mleketlerine tarqalg'an.



Qi'ziqli' matematikag'a tiyisli ma'sa'leler

1 den 99 g'a shekemgi natural sanlar izbe-iz jazi'li'p, uzi'nnan uzi'n u'lken san payda yetildi. Bul sanda 1 cifri' neshe ma'rte jazi'lg'an? 2 cifri' ne?

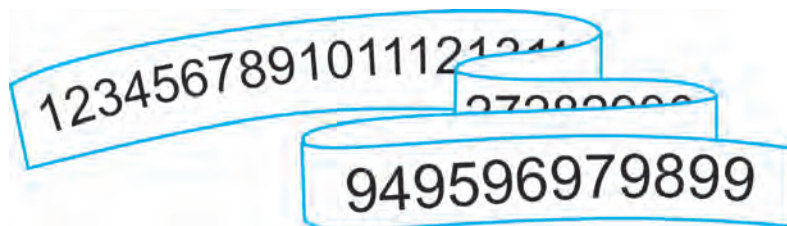

2-§.

KESMA. KESMANING UZUNLIGI. UCHBURCHAK

2.1. Kesindi

Noqat yen' a'piwayi geometriyalıq figura. Woni su'wretlew ushi'n dapterge ushli' qa'lemd i tiygiziw jetkilikli (1- su'wret). Noqatlar u'lken lati'n ha'ripleri menen belgilenedi. 2- su'wrette A, B, C, D noqatlari su'wretlengen.

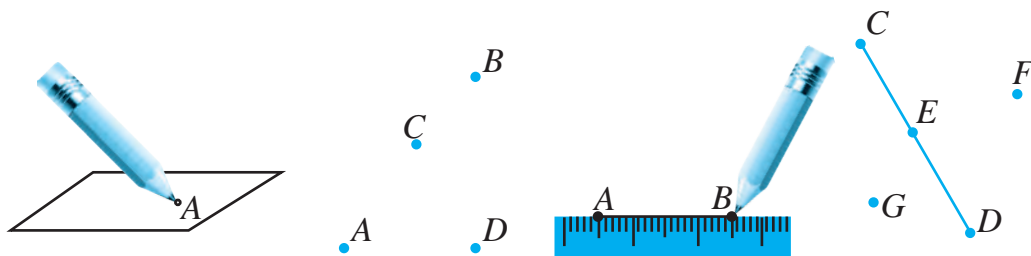

1-su'wret

2-su'wret

3-su'wret

4-su'wret

Da'pterin'izge A ha'm B noqatlari'n belgilep, wolardi' si'zg'i'sh ja'rdemide tu-tasti'rsan'i'z AB kesindisi payda boladi' (1-su'wret). Woni' BA kesindisi dep te bel-gilew mu'mkin. A ha'm B noqatlar AB kesindisinin' ushleri' dep ataladi'.

Qa'legen yeki noqatti' tek g'ana bir kesindi menen tutasti'ri'w mu'mkin.



Yekinshi su'wrette CD kesindisi su'wretlengen. E noqati' usi' kesindige tiyisli ha'm wol C ha'm D noqatlari' arasi'nda jatadi'. F ha'm G noqatlari' bolsa usi' ke-sindige tiyisli yemes.

Kesindilerdi cirkul ja'rdemide 5–6-su'wretlerdegidey sali'sti'ri'w mu'mkin. 5-su'wrettegi AB ha'm MK kesindileri **ten'** boladi' ha'm bul $AB = MK$ tu'rinde jazi'ladi'.

6-su'wrette su'wretlengen AB kesindi MK kesindinin' bo'leginen ibarat. Woni'n' ushi'n AB kesindi MK kesindiden **qi'ssqa**, MK kesindi bolsa AB kesindiden **uzi'n**.

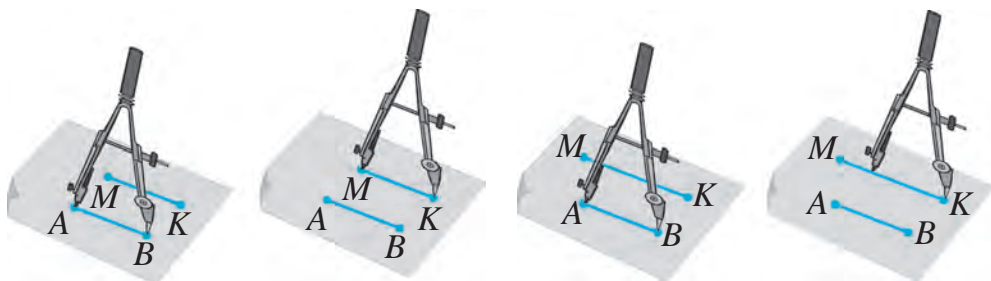

5-su'wret

6-su'wret

2.2. Kesindinin' uzi'nli'g'i'. U'shmu'yeshlik

Ha'r bir kesindi belgilengen uzi'nli'qqa iye.



7-su'wrette u'sh kesindi berilgen. Birinshi AB kesindinin' uzunligi 1 sm ge ten'. AB kesindi MN kesindiden u'sh ma'rte, EF kesindige bolsa 4 ma'rte boli'p jayla-

sadi'. U'i sig'an baylani'sli MN kesindinin' uzi'nligi 3 sm ge, EF kesindinin' uzi'nligi bolsa 4 sm g'a ten' dep aytami'z ha'm $MN = 3$ sm, $EF = 4$ sm tu'rinde jazami'z.

MN ha'm EF kesindilerinin' uzi'nlig'in 1 santimetrlik birlik kesindi ja'rdeminde, yag'niy santimetrlerde wo'lishedik. Kesindilerdin' uzunlig'i'n basqa uzunli'q birlikleri: millimetr, decimetr, metr, kilometrlerde de wo'lishew mu'mkin. 8-su'wrette su'wretlengen CD kesindinin' uzi'nli'g'i 17 mm ge ten'.

A'dette kesindinin' uzi'nli'g'i' si'zgi'sh ja'rdeminde wo'lishenedi. Sonday-aq, si'zgi'shtan belgili uzi'nli'qqa iye bo'lgan kesindi jasawda (si'zi'wda) da paydalaniladi'. 9-su'wrette uzi'nli'g'i' 23 mm ge ten' bo'lgan EF kesindi si'zi'w procesi ko'rsetilgen.

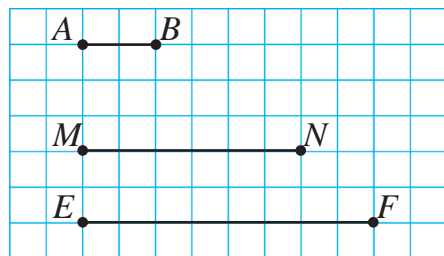

7-su'wret

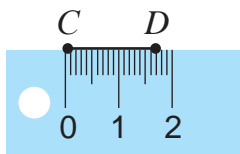

8-su'wret

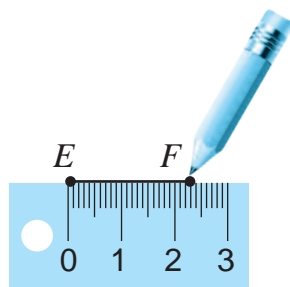

9-su'wret



Kesindinin' uzini'g'i'n wo'lishew – wog'an birlik kesindi neshe ret jaylusi'win aniqlawdun iborat.

Uzi'nli'q wo'lishem birlikleri arasi'nda to'mendegi qatnaslar bar:

$$\begin{array}{lll} 1 \text{ sm} = 10 \text{ mm}, & 1 \text{ dm} = 10 \text{ sm}, & 1 \text{ km} = 1000 \text{ m}, \\ 1 \text{ m} = 10 \text{ dm}, & 1 \text{ m} = 100 \text{ sm}, & \end{array}$$

10-su'wrette su'wretlengen AB kesindiden ali'ng'an C noqat woni' AC ha'm CB bo'leklerge aji'ratadi'. Bul jag'dayda AB kesindinin' uzi'nli'g'i' woni'n' bo'lekleri AC ha'm CB kesindilerdin' uzi'nli'qlari'ni'n' qosi'ndi'lari'nan ibarat boladi' ha'm bul

$$AB = AC + CB$$

tu'rinde jazi'ladi'.

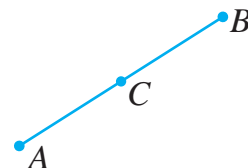

10-su'wret



Kesindi woni'n' ushlari'n tutasti'ri'wshi' qa'legen si'zi'qtan qi'sqa boladi'.

AB kesindi uzi'nli'g'i'n A ha'm B noqatlar arasi'ndag'i' arali'q dep te aytiladi'. Bir tuwri' si'zi'qta jatpaytug'i'n A , B ha'm C noqatlari'n da'pterde belgilep, wolar-di' kesindiler menen tutasti'ri'p shi'qsaq, *u'shmu'yeshlik* payda boladi' ha'm wol "ABC *u'shmu'yeshlik*" si'yaqli' belgilenedi (11-su'wret).

A , B ha'm C noqatlari' ABC *u'shmu'yeshliktin' to'beleri*, AB , BC , AC kesindileri bolsa, *woni'n' ta'repleri* dep ataladi'.

U'shmu'yeshlik ta'replerinin' uzi'nli'qlari'ni'n' qosi'ndi'si' u'shmu' yeshliktin' perimetri dep ataladi'.

12-su'wrette $MNLK$ to'rtmu'yeshlik su'wretlengen. M , N , L ha'm K noqatlar to'rtmu'yeshliktin' to'beleri, MN , NL , LK ha'm KM kesindiler woni'n' ta'replerinen ibarat.

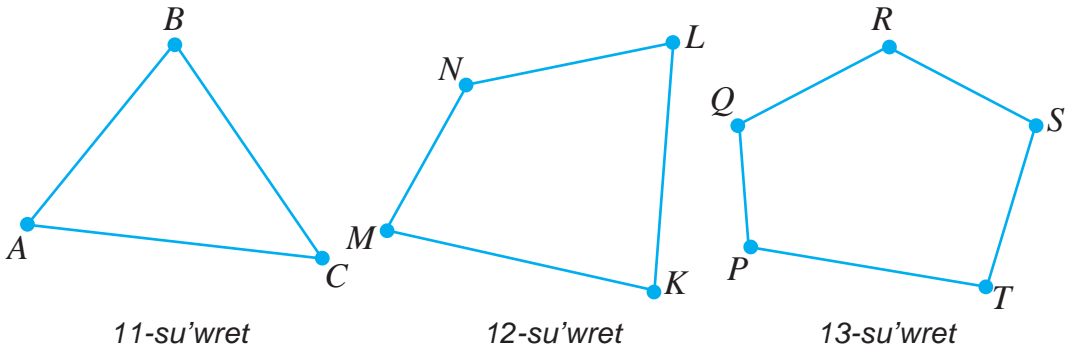

To'rtmu'yeshliktin' perimetri woni'n' barli'q ta'replerinin' qosi'ndi'si'nan ibarat. 13-su'wrette $PQRST$ besmu'yeshlik su'wretlengen.

U'shmu'yeshlik, to'rtmu'yeshlik, besmu'yeshlik ha'm tag'i' basqa figuralar uli'wma atama menen *ko'pmu'yeshlikler* dep ataladi'.

Sorawlarg'a juwap berin'!



1. Kesindi qalay si'zi'ladi'?
2. A ha'm B noqatlari'n neshe kesindi menen tutastiri'w mu'mkin?
3. Yeki kesindi bir-biri menen qalay sali'stir'aladi'?
4. Kesindinin' uzi'nlig'i' qalay wo'lshenedi?
5. Qanday uzi'nli'q wo'lshem birliklerin bilesiz?
6. U'shmu'yeshlik qalay si'zi'ladi'?
7. Ko'pmu'yeshliktin' perimetri qalay tabi'ladi'?

Klasta wori'nlanatug'i'n shi'ni'g'i'wlar



28. Da'pterin'izge yeki noqat belgilen'. Wolardi' P ha'm Q noqatlari' menen belgilen' ha'm si'zg'i'sh ja'rdeminde tutastiri'n'. Payda bolg'an kesindini jazi'n'.

29. 14- su'wrette su'wretlengen barli'q kesindilerdi ayti'n'.

a)



14-su'wret

b)

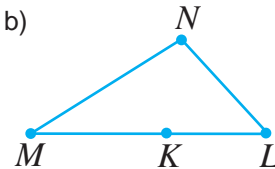

30. 15- su'wrettegi qaysi' noqatlar CD kesindisine tiyisli? Qaysi noqatlar bul kesindige tiyisli yemes? CD kesindisine K noqat woni'n' berilgen qaysi' noqatlari' arasi'nda jatadi'?

31. 16- su'wrettegi KL kesindisin cirkul ja'rdeminde qalg'an kesindiler menen sali'stir'i'n'. Bul kesindi qaysi' kesindilerden uzi'n? Qaysi kesindilerden qi'ssa?

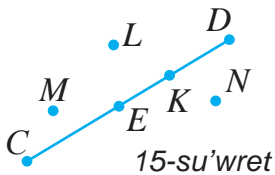

15-su'wret

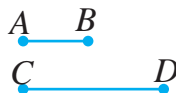

16-su'wret

32. 16-su'wrette AB kesindini birlik kesindi (yag'ni'y uzi'nli'g'i'i 1 ge ten') dep ali'p, qalg'an kesindiler uzi'nli'qlari'n cirkul ja'rdeminde tabi'n'.

33. A'mellerdi wori'nlan':

a) $1420 - 40 : 2;$

b) $(232 + 8) : 10 + 124;$

d) $121 : 11 + 12 \cdot 10;$

e) $(203 - 199) \cdot 100 + 120 : 2.$

34. 3 cifri' qatnasqan barli'q yeki qanali' sanlardi' jazi'n'.

35. Skladta 345 t kartoshka bar yedi. Birinshi ha'ptede 27 t, yekinshi ha'ptede bolsa birinshi ha'ptege qarag'anda 8 t kem kartoshka sati'wg'a shi'g'ari'ldi'. Skladta neshe tonna kartoshka qaldi'?



36. Sxema tiykari'nda to'mendegi sorawlarg'a juwap berin':



a) 1 santimetr neshe millimetr?

b) 1 decimetr neshe santimetr?

d) 1 metr neshe millimetr?

e) 1 kilometr neshe decimetr?

37. Santimetrlerde an'lati'n':

a) 5 dm 8 sm; b) 3 dm 3 sm; d) 23 dm 8 sm; e) 11 dm 4 sm.

U'lgi: $6 \text{ dm } 2 \text{ sm} = 60 \text{ sm} + 2 \text{ sm} = 62 \text{ sm}.$

38. Decimetr ha'm santimetrlerde an'lati'n':

a) 23 sm; b) 63 sm; d) 39 sm; e) 214 sm.

U'lgi: $78 \text{ sm} = 70 \text{ sm} + 8 \text{ sm} = 7 \text{ dm } 8 \text{ sm}.$

39. Og'zaki hisoblang:

a) $16 + 77;$

b) $58 - 26;$

d) $55 + 35;$

e) $35 + 39;$

f) $4 \cdot 202;$

g) $100 \cdot 600;$

h) $205 : 5;$

i) $444 : 6.$

40. Qatiyshani'n' 2500 swm puli' bar yedi. Wol 500 swmg'a da'pter ha'm 600 swmg'a muzqaymaq sati'p aldi'. Qatiysha neshe swm sarplag'an. Woni'n' ja'ne qansha puli' qaldi'?

41. U'yden kinoteatrg'a shekemgi bolg'an arali'q 1200 m, mektepke shekemgi arali'q bolsa 850 m. U'yden mektepke shekemgi bolg'an arali'q kinoteatrg'a shekemgi arali'qtan neshe metr qi'sqa?



42. To'mendegi kesindilerdin' uzi'nli'g'i'n si'zg'i'sh ja'rdeminde wo'lshen'.

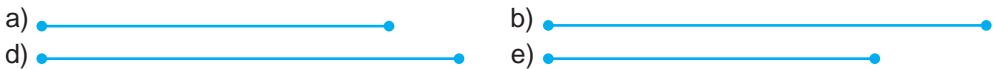

43. Su'wrette su'wretlengen AB kesindinin' uzi'nli'g'i'n tabi'n'. AB kesindinin' uzi'nli'g'i'n si'zg'i'sh ja'rdeminde wo'lshep, na'tiyjeni tekserin'.



44. AB kesindisin C ha'm D noqatlari' izbe-iz kelgen AC , CD ha'm DB bo'leklerge aji'ratadi'. Yeger AC kesindisinini' uzi'nli'g'i'i 21 mm, CD kesindi AC kesindinin 6 mm uzi'n, DB kesindi bolsa CD dan 7 mm qi'sqa bolsa, AB kesindisinini' uzi'nli'g'i'n tabi'n'.

45. **A'meliy shi'ni'g'i'w.** a) Si'zg'i'sh ja'rdeminde da'pter, kitap ha'm parta uzi'nli'g'i'n ha'm yenin wo'lshen'; b) Si'zg'i'sh ja'rdeminde qari'si'n'i'z uzi'nli'g'i'n 17-su'wrette ko'rsetilgandey wo'lshen'.

Qari'si'n'i'z uzi'nli'g'i'n yadta tuti'n'!

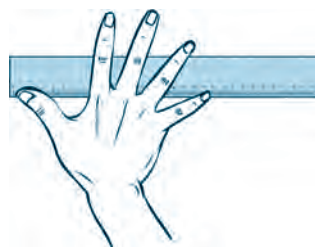

17-su'wret

46. Da'pterin'izge u'shmu'yeshlik si'zi'n' ha'm woni' belgilen' ha'm woni'n' to'belerine ha'm ta'repleri-ne say belgiler menen jazi'n'. U'shmu'yeshlik ta'replerinin' uzi'nli'qlari'n si'zg'i'sh ja'rdeminde si'zi'n' ha'm woni'n' perimetrin tabi'n'.

47. Ko'pmu'yeshliklardi da'pterin'izge si'zi'n' ha'm belgilen'. Si'zg'i'sh ja'rdeminde wolardi'n' ta'replerinin' uzi'nli'qlari'n millimetrlerde wo'lshen' ha'm perimetrin tabi'n'.

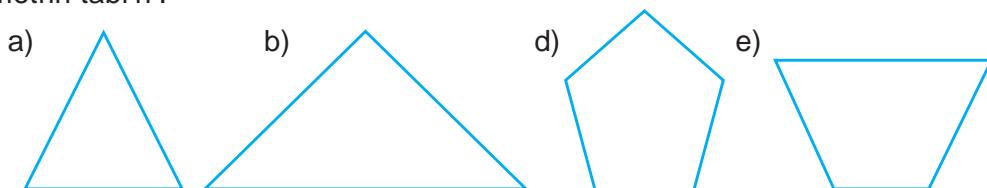

48. A'mellerdi wori'nlan':

a) $(3568 + 232) : 2$; b) $(592 + 8) : 12$; d) $21 \cdot 12 - 135$; e) $19 \cdot 41 + 312$.

- 49.



U'yde wori'nlanatug'i'n ma'seleler



50. AB kesindi si'zi'n' ha'm wog'an tiyisli C ha'm D noqatlari'n belgilen'. Bul noqatlar AB kesindini qanday kesindilerga aji'ratadi'?
51. A, B, C, D ha'm noqatlari'n da'pterin'izge belgilen'. O noqati'n qalg'an noqatlardi'n' ha'r biri menen kesindiler ja'rdeminde tutasti'ri'n'. Payda bolg'an kesindilerdi jazi'n'.
52. Su'wrette berilgen kesindiler arasi'nan yen' uzi'ni'n ha'm yen' qi'sqasi'n sirkul ja'rdeminde ani'qlan'. MN kesindi qaysi' kesindilerden uzi'n ha'm qaysi' kesindilerden qi'sqa yekenligin ani'qlan'.

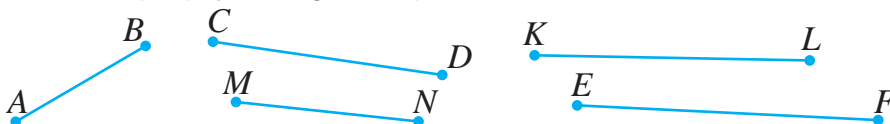

53. 36-ma'seledgegi sxema tiykari'nda to'mendegi sorawlarg'a juwap berin':

- a) 10 santimetr neshe millemetr? d) 6 metr neshe decimetr
b) 5 decimetr neshe millimetr? e) 2 kilometr neshe millimetr?

54. Millimetrlerde an'lati'n':

- a) 5 sm 9 mm; b) 4 dm 6 sm 7 mm; d) 9 dm 2 sm.



55. Santimetr ha'm millimetrlerde an'lati'n':
 a) 438 mm; b) 907 mm; d) 223 mm; e) 768 mm.

56. AB kesindini C noqati' AC ha'm CB bo'leklerge aji'ratadi'. Yeger AC kesindinin' uzi'nli'g'i' 56 sm boli'p, wol CB kesindiden 23 sm qi'sqa bolsa, AB kesindisinin' uzi'nli'g'i'n tabi'n'.
57. AB kesindini C ha'm D noqatlari' izbe-iz kelgen AC , CD ha'm DB bo'leklerge aji'ratadi'. Yeger AC kesindinin' uzi'nli'g'i' 34 mm, CD kesindi AC kesindiden 12 mm qi'sqa, DB kesindi bolsa AD dan 25 mm qi'sqa bolsa, AB kesindinin' uzi'nli'g'i'n tabi'n'.
58. ABC u'shmu'yeshlikte a) $AB = 12$ sm, $BC = 32$ sm, $AC = 28$ sm; b) $AB = 5$ dm, $BC = 3$ dm, $AC = 4$ dm; d) $AB = 43$ mm, $BC = 5$ sm, $AC = 38$ mm bolsa, woni'n' perimetrin tabi'n'.



Matematika tariyxi'na tiyisli u'zindiler

U'lkemizde yertede qollani'lg'an wo'lishem birlikleri

U'lkemizde yertede qollani'lg'an wo'lishem birlikleri Wortu Aziya jerlerinde a'yyemde ha'r tu'rli wo'lishem birlikleri qollani'lg'an. Ha'zirde bul wo'lishem birlikleri go'nerip, derlik qollani'lmay qalg'an. Sonday bolsa da, jasi' u'lken atalari'mi'z tilinde, tariyxi'y kitaplarda ha'm a'debiy shi'g'armalarda bul wo'lishem birlikleri ushi'rap turadi'.

Ma'selen Zahiriddin Muha'mmed Baburdi'n' (Baburnama) shi'g'armasi'nda ha'r tu'rli yellerdin' wo'lishem birlikleri keltirilgen. Mine wolardi'n' bazi biewleri ha'm wolardi'n' ha'zirgi wo'lishem birliklerindegi ma'nisleri menen tani'si'n':

Uzi'nli'q wo'lishem birlikleri si'pati'nda qa'dem (sha'ma menen 70-75 sm), qari's (19-22 sm), qulash (166-170 sm), barmaq (2 sm), tirsek (50-80 sm), gaz (70 sm), shaqi'ri'm (900m), ag'ash (8 km), qari' (55 sm) ha'm mush (8 sm) si'yaqli'lar qollani'lg'an.

Massani' wo'lishew ushi'n mi'sqal (sha'ma menen 4 g), qadaq (410 g), pud (16 kg 380 g), batpan (163 kg 800g) si'yaqli' birlikler qollani'lg'an.



Qi'ziqli' matematikag'a tiyisli ma'seleler

Wo'z ko'zin'izge isenesiz be?

To'mende berilgen kesindiler jupli'g'i'n ko'z benen sha'malap sali'sti'ri'n'. Wolardan qaysi' biri uzi'n? Yendi bul kesindiler uzi'nli'qlari'n si'zg'i'sh penen wo'lshep sali'sti'ri'n'. Demek na'tiyje qanday boldi'?

Usi'nday, *barqulla da ko'zge iseniw kerek yemes!*

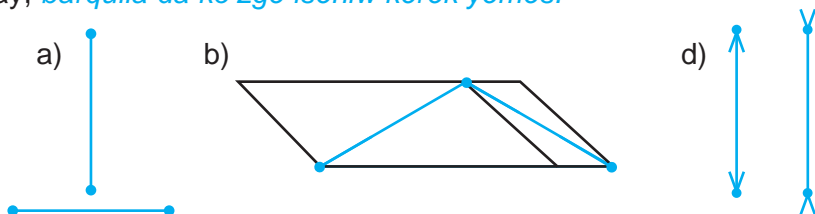

3-§.

TEGISLIK, TUWRI' HA'M NUR

Da'pterge ju'da' uzi'n kesindilerdi si'zi'wdi'n' ila'ji joq. Soni'n' ushi'n si'zi'latug'in kesindilerdin' uzi'nli'g'i'na qarap, da'pterdin' wo'lshemleri mektep doskasi', pol, paqsa yamasa futbol stadioni'ni'n' u'lkenligi boli'wi' kerek. Keltirilgen bul betlerdi'n' barli'g'i' shegaralang'an boli'p, wolar bizge tek tegisliktin' belgili bir bo'legi haqqi'nda ko'z-qaras beredi.

Tegisliktin' bolsa shegarasi' joq, wol sheksizlik. Usi'g'an baylani'sli', tegislikti su'wretlewdin' ilaji' joq. Woni' tek g'ana ko'z aldi'na keltiriw mu'mkin. Tegislikte qa'legen uzi'nli'qtag'i kesindini si'zi'w, woni' si'zgi'sh ja'rdeminde ha'r yeki tarepke qa'legenshe dawam yettiriw mu'mkin.

Tegislikte AB kesindi berilgen bolsi'n. Woni' si'zgi'sh ja'rdeminde ha'r yeki ushi' ta'repine qa'legenshe dawam yettirimiz (1-su'wret). Na'tiyjede *tuwri' si'zi'q* payda yetemiz. U « AB tuwri' si'zi'q» yamasa « BA tuwri' si'zi'q» si'yaqli' belginedi.

Tuwri' si'zi'qti'n' shegi joq. Woni'n' ha'r yeki ushi' sheksiz dawam yetken boladi'.

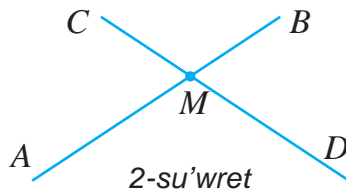
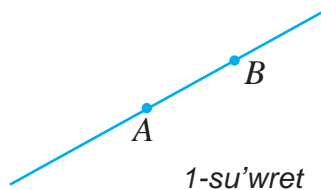

Tegislikte A ha'm B noqtalar berilgan bo'lsi'n (1-su'wret). Si'zgi'sh ja'rdeminde bul noqatlardan wo'tiwshi tuwri' si'zi'q wo'tkeremiz. Bul noqatlardan ja'ne bir tuwri' si'zi'q wo'tkeriw din' ilaji' joq.

Ha'r qanday yeki noqattan tek g'ana bir tuwri' si'zi'q wo'tkeriw mu'mkin.



Yeger yeki tuwri' si'zi'q uli'wma noqatqa iye bolsa, wolar bul noqatta *kesilisedi* delinedi (2-su'wret). M noqat AB ha'm CD tuwri' si'zi'qlardi'n' *kesilisiw noqati'* boladi'.

AB tuwri' si'zi'qta ali'ng'an O noqati' woni' yeki bo'lekke aji'ratadi' (3-su'wret). Wo bo'leklar ha'r bir, O noqati' penen birgelikte *nur* dep ataladi'. O noqat *nurdi'n' ushi'* dep ataladi'.

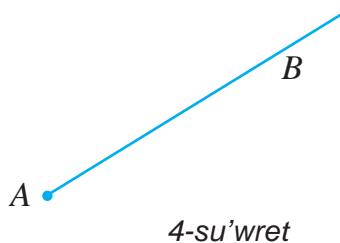
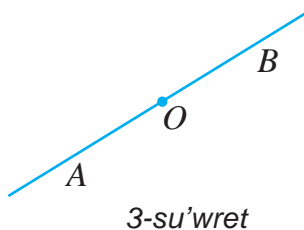

Nurdi'n' shegi joq.



4-su'wrettegi nur bas lati'n har'ipleri menen AB tu'rinde belgilenedi ha'm « AB nur» dep woqi'ladi'. Bul jazi'wda nurdin' ushi' belgilengen A ha'ribi barqulla birinshi bo'li'p jazi'ladi' ha'm woqi'ladi'.



Sorawlarg'a juwap berin'!

1. Tegislik haqqi'nda mag'li'uwmat beretug'i'n bir neshe mi'sallar ayti'n'?
2. Tuwri' si'zi'qti'n' shegi bar ma?
3. Yeki noqattan neshe tuwri' si'zi'q wo'tkeriw mu'mkin?
4. Yeki tuwri' si'zi'q qay waqi'tta bir-biri menen kesilisedi?
5. CD tuwri' si'zi'qta ali'ng'an O noqat woni' qanday nurlarg'a aji'ratadi'?



Klasta wori'nlanatug'i'n shi'ni'g'i'wlar

59. 5- su'wrette su'wretlengen noqatlardi'n' qaysi'lari' a) AB kesindide; b) AB tuwri' si'zi'qta jatadi'? Qaysi'lari' AB kesindide jatpaydi'?

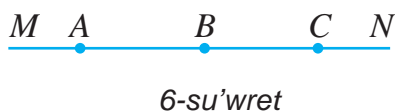
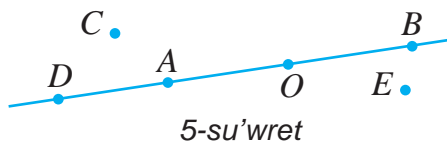

60. Da'pterin'izge MN kesindini si'zi'n'. MN kesindini yeki ushi' ta'replerine dawam yettirin'. MN tuwri' si'zi'qta jatqan A, B ha'm jatpaytug'i'n C, D noqatlardi' belgilen'. Payda bolg'an tuwri' si'zi'qti' ja'ne qanday belgilew mu'mkin?

61. 6-su'wrette su'wretlengen barli'q tuwri' si'zi'q ha'm nurlardi' ayti'n'.

62. 7- su'wrette su'wretlengen AB, CD ha'm OE nurlardi'n' qaysi'lari' wo'zara kesilisedi? Qaysi'lari' wo'z-ara kesilispeydi?

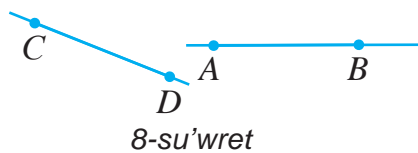
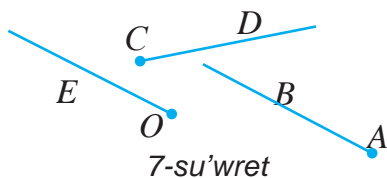

63. 8-su'wrette su'wretlengen to'mendegi figuralar wo'z-ara kesilise me?

- | | |
|---------------------------------------|--|
| a) AB ha'm CD kesindiler; | b) BA ha'm DC nurlar |
| d) AB kesindi ha'm DC nur; | e) AB nur ha'm CD kesindi; |
| f) AB tuwri' si'zi'q ha'm CD nur; | g) AB tuwri' si'zi'q ha'm CD tuwri' si'zi'q. |

64. Kesilisiwshi yeki tuwri' si'zi'q tegislikni neshe bo'lekke bo'ledi?

65. Da'pterin'izge PQR u'shmu'yeshligin si'zi'n'. PQ, QR ha'm RP tuwri'lari' tegislikni neshe bo'lekke aji'ratadi'?

66. Metr, decimetr ha'm santimetrlerde an'lati'n':

- | | | | |
|------------|-------------|-----------|-------------|
| a) 223 sm; | b) 1852 sm; | d) 59 sm; | e) 3783 sm. |
|------------|-------------|-----------|-------------|

U'yde wori'nlanatug'i'n ma'seleler



67. 9-su'wrette su'wrtlengen barli'q tuwri' si'zi'q ha'm nurlardi' jazi'n'.

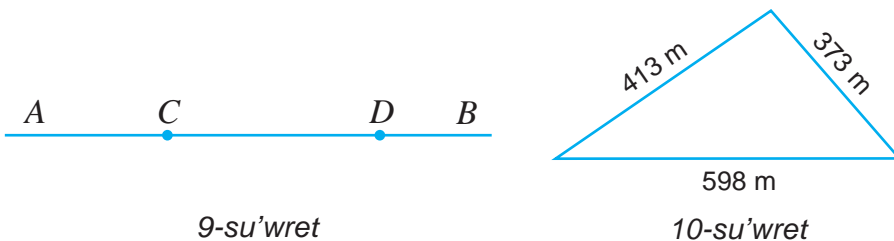

- 68. M noqati'n belgilen'. MN ha'm ML nurlari'n si'zi'n'. Bul nurlardi'n' ushi' qaysi' noqat boladi'?
- 69. Bir-biri menen kesilisiwshi u'sh tuwri' si'zi'q si'zi'n' ha'm wolar tegislikti ko'bi menen neshe bo'lekke aji'ratadi'?
- 70. 10-su'wrette su'wrtlengen u'shmu'yeshlik formasi'ndag'i' jer maydani'n yeki qatar si'm menen woraw ushi'n neshe metr si'm kerek boladi'?

Matematika tariyxi'na tiyisli u'zindiler



Angliyada uzaq ji'llar uzi'nli'q wo'lshem birlikleri si'pati'nda dyuym ha'm fut qollani'lg'an. 1 dyuym sha'ma menen 25 mm ge ten' boli'p, woni'n' ati' inglizshe bas barmaq buwi'ni' ati'nan ali'ng'an. Fut bolsa taban ati'nan kelip shi'qqan boli'p, sha'ma menen 30 sm 5 mm ge ten' yep ali'ng'an:
 $1 \text{ fut} = 12 \text{ dyuym}$.

Ha'zirde de bul wo'lshem birlikleri ayi'ri'm jag'daylarda qollani'ladi'. Ma'selen, televizor, kompyuter, noutbuk, qol telefoni', smartfonlar manitori' diagonali'ni'n' wo'lshemi dyuymalarda wo'lshenedi.

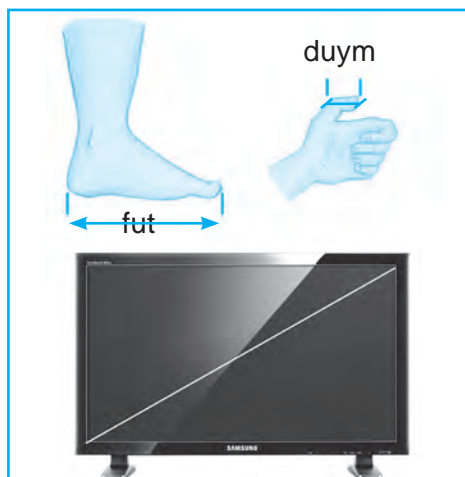

Qi'ziqli' matematikag'a tiyisli ma'seleler



To'mendegi tapsi'rmalarda wortada, qawsi'rma ishinde jazi'lg'an sany eki shette turg'an sanlardan belgili aridmetikali'q a'meller ja'rdeminde payda qi'li'ng'an. "?" belgisi worni'na tu'sirip qaldi'ri'lg'an sandi' jazi'n':

- a) 42 (47) 5 b) 6 (66) 11 d) 36 (25) 11 e) 48 (4) 12
- 31 (?) 8 5 (?) 12 48 (?) 12 100 (?) 5

4-§.

SHKALALAR HA'M KOORDI'NATALAR. SANLAR NURI

4.1. Shkalalar

Ag'ashtan islangen tegis reyka ja'rdeminde *A* ha'm *B* noqatlari'n tutastiri'p kesindi si'zi'w mu'mkin (1-su'wret). Biraq, bul a'sbap ja'rdeminde kesindinin uzi'nli'g'in wo'lshe'wge bolmaydi. Buni'n' ushi'n a'sbapti' ja'ne de i'qsha'mlasti'rami'z.

Woni'n' joqari' shetine ha'r bir santimetrden keyin tuwri' si'zi'qshalar si'zi'p shi'g'ami'z (1-su'wret). Si'zi'qshalar asti'na 0 den baslap, 1, 2, 3 ha'm t.b sanlardi' ta'rtip penen jazi'p shi'g'ami'z.

Na'tyjede, si'zi'qsha ha'm sanlardan ibaret shkala payda yetemi'z. Bul jag'dayda reyka'ga bir bo'leyinin u'zi'nli'g'i' 1 sm bolg'an *shkala* tu'sirilgen dep ayti'ladi'.

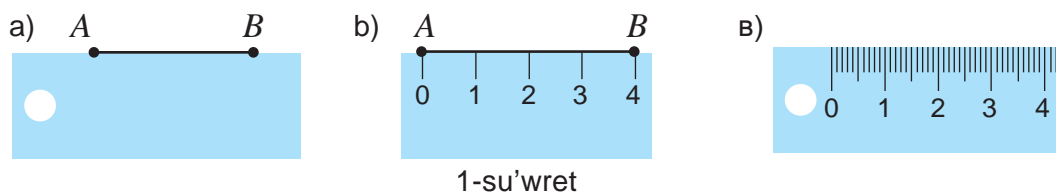

1-su'wret

Si'zg'i'shti'n' ha'r bir bo'liminin' uzi'nli'g'i' 1mm ge ten' boli'p, wol bo'limnin' ma'nisin bildiredi. 1.d-su'wrette su'wrtlengen *AB* kesindi uzi'nli'g'i' 40 mm ge yaki 4 sm ge ten'.

Shkalalar tiykari'nan ruletka, saat, termometr, ta'rezi, avtomobil spidometri si'yaqli' wo'lshe'w a'sbaplari'nda qollani'ladi' 2-su'wret.

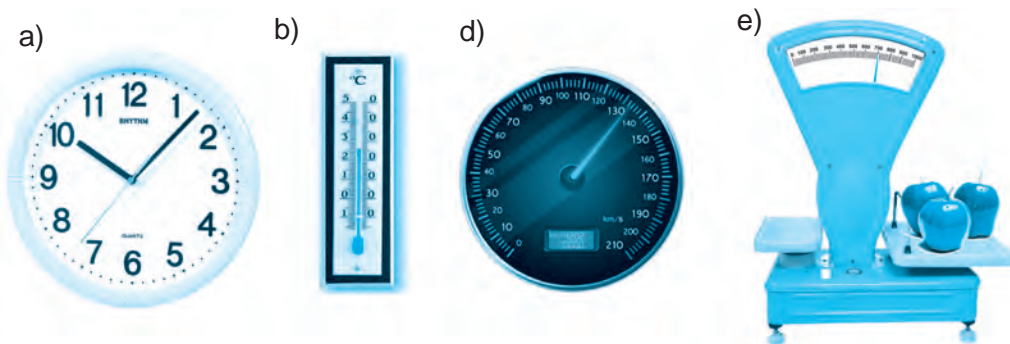

2-su'wret

2. b – su'wrette su'wrtlengen temperaturani' wo'lsheytug'i'n a'sbap-termometr shkalasi' 40 bo'limnen ibarat boli'p, wol Selsiy shkalasi' dep ataladi' ha'm woni'n' ha'rbir bo'limi 1 gradus (1°C) ti' an'latadi'. Termometr 30° C ti ko'rsetip turi'pti'.

2. e – su'wrette su'wrtlengen ta'rezi shkalasi'na qarap pomidordi'n' massasi' 2 kg 700 g yekendligini ani'qlaw mu'mkin.

Massani'n' tonna (t), centner (ts) si'yaqli' wo'lshe'w birlikleri de boli'p, wolar bir-biri menen to'mendegi ten'likler menen baylani'sqan:

$$1 \text{ kg} = 1000 \text{ g}, \quad 1 \text{ ts} = 100 \text{ kg}, \quad 1 \text{ t} = 1000 \text{ kg}.$$

4.2. Sanlar nuri'

Ushi' O noqatta bolg'an, shepten won'g'a qarap gorizonta' bag'i'tlang'an. OX nuri'n si'zami'z (3-su'wret). Bul bag'i'tti' nur su'wretinin' won' ta'repine qoyi'lg'an strelka ko'rsetip turi'pti'. Bul nurda qa'legen E noqati'n belgileymiz. Payda bolg'an. OE kesindini *birlik kesindi* si'pati'nda alami'z.

Nurdi'n' ushi' O noqati' asti'na 0 sani'n, E noqati' asti'na 1sani'n jazami'z. Bul jag'dayda *E noqati' OX nuri'nda 1 sani'n su'wretleydi.*

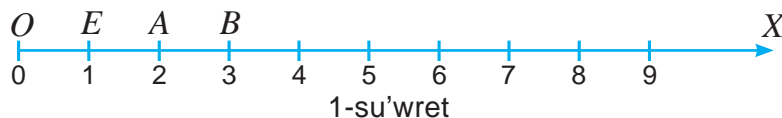

OX nuri'nda 2 sani'n su'wretlew ushi'n nurg'a birlik kesindi O noqattan izbe-iz yeki ma'rte qoyami'z. Payda bolg'an A noqati' nurda 2 sani'n su'wretleydi. Yeger nur ushi'nan birlik kesindini u'sh ma'rte izbe-iz qoysaq, 3 sani'ni'n' nurdagi' su'wreti – B noqati'n payda yetemiz h.t.b.

Nurdi'n' aqiri' bolmag'ani' ushi'n qa'legen natural sanlardi' nurda joqari'dagi' usi'ldan paydalani'p su'wretlew mu'mkin. Na'tiyjede sheksiz shkalani' payda yetemiz. Bul shkala *sanlar nuri'* ya'ki *koordinatalar nuri'* dep ataladi'.

O, E, A, B noqatlarga sa'ykes kelgen 0,1,2,3 sanlari' bul *noqatlardi'n' koordinatalari'* dep ataladi' ha'm $O(0), E(1), A(2), B(3)$ tu'rinde jazi'ladi'.

Ko'rip turg'ani'n'i'zday, strelka boylap noqatlardi'n' koordinatalari' wo'sip baradi' ha'm kerisinshe, strelkag'a qarama-qarsi' bag'i'tta noqatlar koordinatalari' kemeyip baradi'.

Sanlar nuri'nda ha'r qanday natural san noqat penen su'wretlenip, wo'zinin' belgilengen worni'na iye.



4.3. Bag'anali' diagrammalar

Shkalalardan bag'anali' formada diagrammalardi' du'ziwde de paydalani'ladi'. Bag'anali' diagrammalar tu'rli mag'li'wmatlardi' wo'z-ara sali'sti'ri'w ha'm ko'rgizbeli yetip su'wretlewde qollani'ladi'.

Mi'sal. Kestede berilgen mag'li'wmatlar tiykari'nda bag'anali' diagramma du'zin'.

U'lgili woqi'wshi'lar haqqi'nda mag'li'wmat

Klaslar	5- «A»	5- «B»	5- «D»
U'lgili woqi'wshi'lar sani'	8	6	5

Jasaw: Diagrammani u'sh bag'anadan ibarat yetip du'zemiz: 1-bag'ana – 5-A, 2-bag'ana – 5-B, 3-bag'ana – 5-D klastag'i u'lgili woqi'wshi'lar sani'n ani'qlasi'n. U'lgili woqi'wshi'lar sani'n ko'rsetiwshi shkalani tik (bag'ana) tu'rind si'zami'z.

U'lgili woqi'wshi'lar sani'nan kelip shi'g'i'p, uzi'nli'g'i' sa'ykes biyiklikke iye bolg'an tuwri'mu'yeshlik formasi'ndag'i' bag'analardi' shkala qasi'na izbe-iz si'zami'z. Payda bolg'an figura (4-su'wret) – u'lgili woqi'wshi'lar sani'n ko'rgizbeli yetip an'lati'wshi' bag'anali' diagrammadan ibarat boladi'.

Geyde bag'analar worni'na tiyisli figura ya'ki su'wretlerdi de qoyi'w mu'mkin.

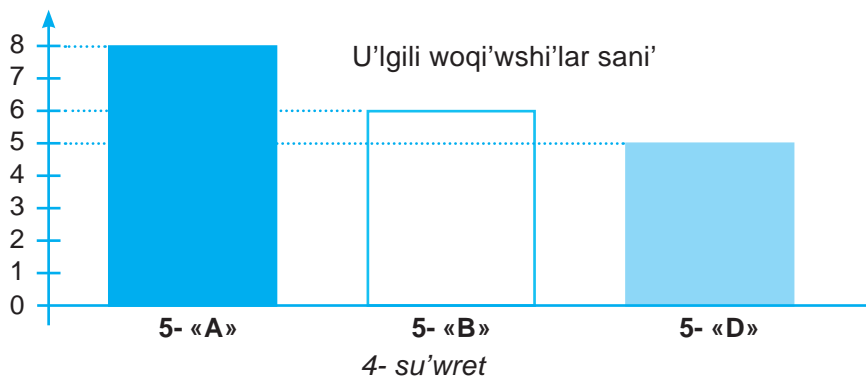

Sorawlarg'a juwap berin'!

1. Si'zg'i'sh shkalasi' nelerden du'zilgen?
2. Shkalali' wo'lishew a'sbaplari'na mi'sal keltirin'.
3. Sanlar nuri' qalay du'ziledi?
4. Noqatti'n' sanlar nuri'ndag'i' koordinatasi' qalay ani'qlanadi'?



Klasta wori'nlanatug'i'n shi'ni'g'i'wlar

71. 2-su'wrette su'wretlengen a'sbaplar ja'rdeminde qanday sha'malar wo'lishenedi? Ha'r bir a'sbapti'n' bir bo'limin' ma'nisi nege ten' ha'm wo'lishenip ati'rg'an sha'malardi'n' ma'nisin tabi'n'.
72. 5-su'wrettegi termometrlar qanday temperaturani' ko'rsetip turi'pti'?

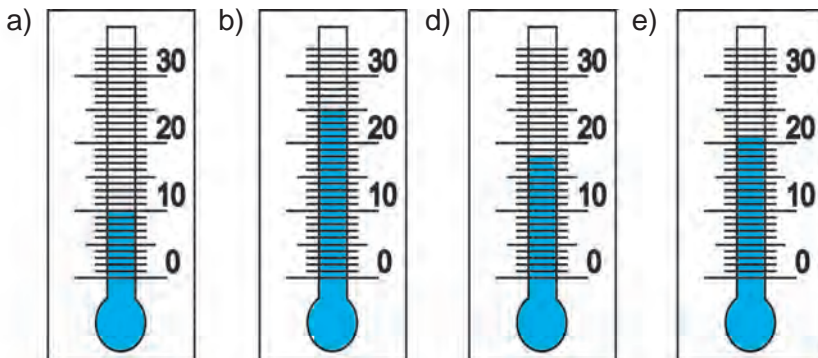

5- su'wret

73. 6-su'wrettegi avtomobil spidometri' shkala bo'liminin' ma'nisin ani'qlan'. Spidometr ja'rdemide ne wo'lishenedi? Wolar neni ko'rsetpekte?



6- su'wret

74. To'mendegi shkalalardi'n' bir bo'leginin' ma'nisin ani'qlan':

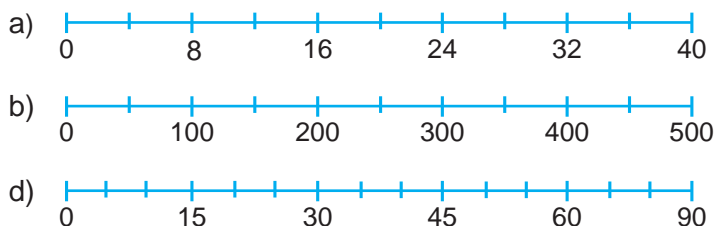

75. Su'wrette ko'rsetilgan telefon, janarmay quyi'w shaqapshasi', meditsinali'q ja'rdem punkti, asxana, dem ali'w worayi' ha'm miymanxana joldi'n' qaysi' kilometrde jaylasqanli'g'i'n ani'qlap sa'ykes no'qatlar koordinatalari'n jazii'n.



76. Sanlar nuri' bo'leginin' ma'nisin tabii'n'. Belgilengen no'qatlar'ga qaysi' sanlar sa'ykes keliwin ani'qlan' ha'm sa'ykes koordinatalari'n jazii'n.

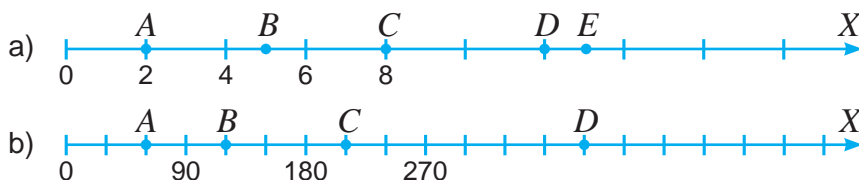

77. Birlik kesindi uzi'nli'g'i'n 1 sm dep ali'p, sanlar nuri'n si'zi'n' ha'm wonda koordinatalari' 2; 4; 7; ha'm 12 bolg'an no'qatlardi' belgilen'.

78. Grammlarda an'lati'n':

- a) 2 kg 453 g; b) 1 kg 810 g; d) 2 ts 20 kg 349 g; e) 5 ts 14 kg 25 g.

79. Kilogramm ha'm grammlarda an'lati'n':

- a) 7532 g; b) 2350 g; d) 52 345 g; e) 127 532 g.

80. Centner ha'm kilogrammlarda an'alati'n':

- a) 2340 kg; b) 75 207 kg; d) 123 320 kg; e) 10 020 kg.

81. Kimnin' awi'rli'g'i' qansha? To'mendegi su'wrette si'zi'lg'an pi'shi'q, adam, si'yi'r, pil, korkidon ha'm iytin' awi'rli'g'i'n sha'malap, berilgen kilogrammlardi' wolarg'a sa'ykes qoyi'n'.

5 kg, 6000 kg, 3000 kg,
300 kg, 25 kg, 70 kg

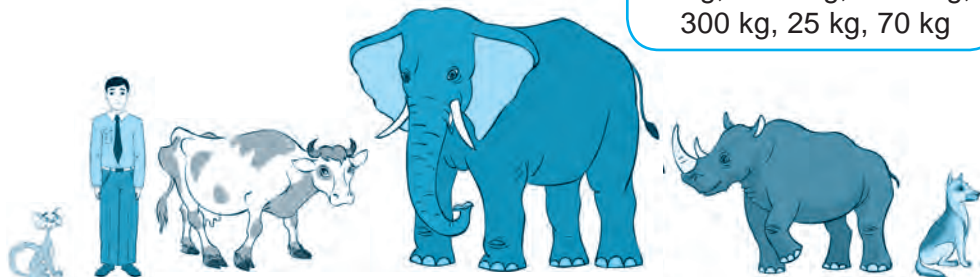

82. Matematika keshesinde Qasimjan ji'ynalg'anlardi' ku'ldiriw maqsetinde bali'q awi'na barg'ani' haqqi'nda gu'rrin' ayti'p berdi. Wol gu'rrin'inde wo'lshem birliklerin bile tura aljasti'ri'p aytti'. Gu'rrin'de Hasimjan jol qoyg'an qa'teliklerdi' ani'qlan' ha'm wolardi' du'zetip gu'rrin'di qayta ayti'p berin'.

Bali'q awi'nda

Men azanda woyani'p saatqa qarasam, waqi't 4 kg 15 g boli'pti'. Da'rha'l bet qoli'mdi' juwdi'm ha'm 1 km su't iship aldi'm. Ku'n salqi'n, 12 saat i'ssi' yedi. Ko'l ta'repke jolg'a shi'qti'm. Men 2 litr tezlik penen ju'rdim ha'm 4 gradus jol basi'p wo'ttim. Ko'lge 2 mde jetip keldim. Tezlik penen bali'q awlawg'a kiristim. 20 sm waqi't wo'tip, birinshi bali'q qarmaqqa ilindi. Woni'n' uzi'nli'g'i' 50 min, massasi' bolsa 4 km yedi. Men bali'q awi'nan kewlim toli'p, u'yge qayi'tti'm.



83. Kesteni tolti'ri'n':

1-qosi'li'wshi'	234		1569
2- qosi'li'wshi'	258	342	
Qosi'ndi'		12670	15890

84. Metal bo'leklerin ji'ynawda u'sh klass qatnasi'p, 5-A klass – 6 tonna, 5-B klass – 5 tonna ha'm 5-D klass woqi'wshi'lari' 8-tonna metal ji'ynadi'. Bul mag'liu'wmatlar tiykari'nda bag'anali' diagramma du'zin'.

85. To'mendegi kestede berilgen mag'liu'wmatlar tiykari'nda bag'anali' diagramma du'zin'.

Terilgen paxta haqqi'nda mag'li'wmat

Diyqan xojali'qlari'	"Bereket"	"Bostan"	"Keleshek"
Terilgen paxta (tonnada)	70	55	90

86. Diagrammadan paydalani'p du'nyadag'i' ba'lent imaratlardi'n' biyikligin tabi'n'.

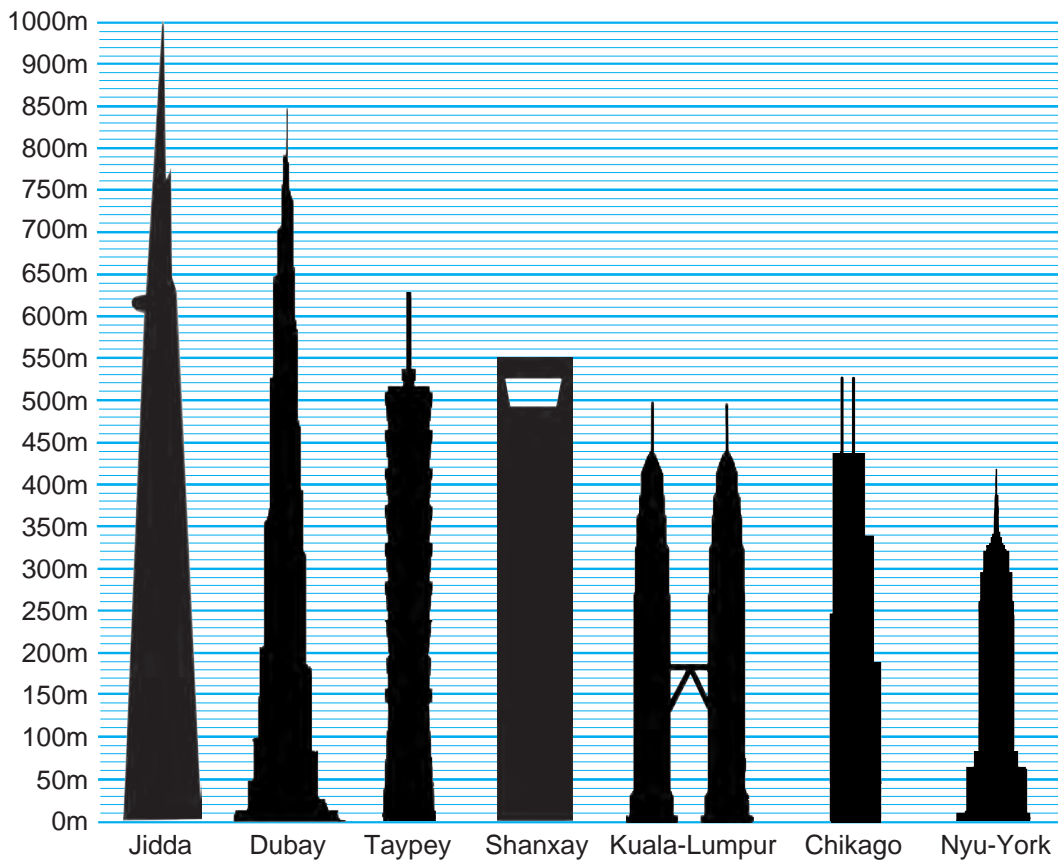

U'yde wori'nlanatug'i'n ma'seleler



87. To'mendegi su'wrette jol shkala ko'riniside su'wretlengen. Shakalani'n' bir bo'liminin' ma'nisin ani'qlan' ha'm jetispeytug'i'n sanlardi' jazi'n'.



88. Sanlar nuri'nda belgilengen noqatlar koordinatalari'n tabi'n'.



89. 7-su'wretegi termometr azang'i' qanday temperaturani' ko'rsetip turi'пти'.

Yeger hawa temperaturasi' tu'ste azang'i'dan 12 bo'limge ko'tergen, keshke bari'p bolsa tu'stegiden 8 bo'limge pa'seygen bolsa, hawa temperaturasi' tu'ste ha'm keshquri'n qanday bolg'an?

90. Birlik kesindi uzi'nli'g'i'n 1 da'pter ketekshesinin' yenine ten' dep ali'p, sanlar nuri'n si'zi'n' ha'm wonda koordinatalari' 4; 8; 15 ha'm 24 bolg'an noqatlardi'.

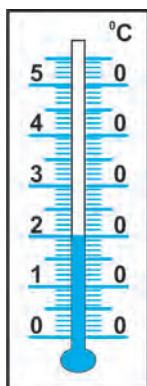

7- su'wret

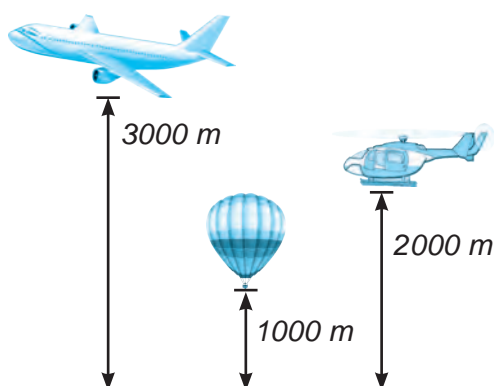

8- su'wret

91. Ko'klem ha'm ko'rkem awi'llari' arasi'ndag'i' arali'q 20 km. Bul awi'llar arasi'ndag'i' joldi' shkala ko'riniside an'lati'n'. Birlik kesindini 1 sm ha'm shkalani'n' bir bo'limin 2 km dep ali'n'. Ko'klem awi'li'nan saati'na 4 km tezlik penen kiyati'rg'an Asi'l'bek a) 1 saat; b) 2 saat; d) 4 saattan keyin shkalani'n' qaysi' noqati'nda boli'wi'n ani'qlan'.
92. Kilogrammlarda an'lati'n':
 a) 7 t 200 kg; b) 4 t 565 kg; d) 1 ts 86 kg; e) 2 t 9 ts 12 kg.
93. Tonna ha'm kilogrammlarda an'lati'n':
 a) 2547 kg; b) 72 904 kg; d) 35 831 kg; e) 701 060 kg.
94. 8- su'wrettegi mag'liu'wmatlardan paydalni'p diagramma du'zin'.
95. 9- Su'wrette keltirilgen bag'anali' diagrammadan paydalai'p, a'yyemgi zamanlarda jasag'an dinazavrlardi'n' massalari'n kilogrammlarda ani'qlan'.

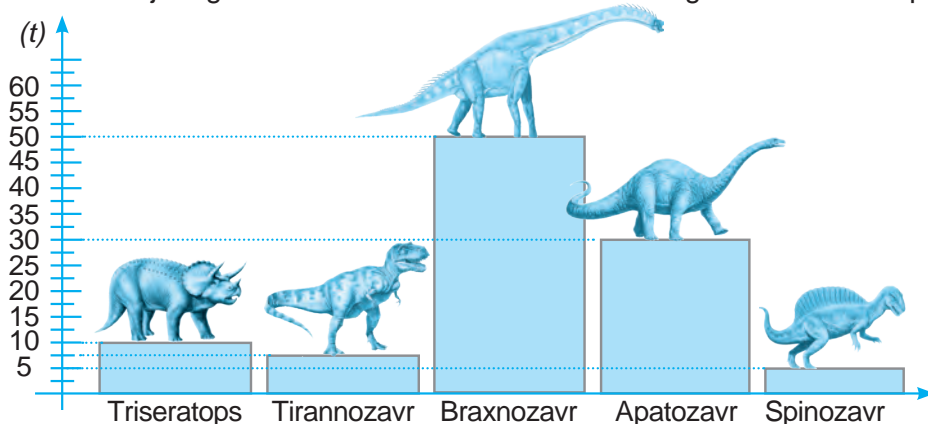

9- su'wret

96. Tashkent teleminarasi' du'nyada biyik minoralaridi'n' biri.

a) Tashkent minarasi Berlin ha'm Vena minarali'nan qansha ba'lent?

b) Toronto, Kuala-Lumpur, Tashkent ha'm Tokio qalalari'ndag'i minaralardi'n' wo'zara sali'sti'ratug'i'n diagramma du'zin'. Shkala du'ziwde da'pterdin' bir ketekshesin 50 metr dep ali'n'.

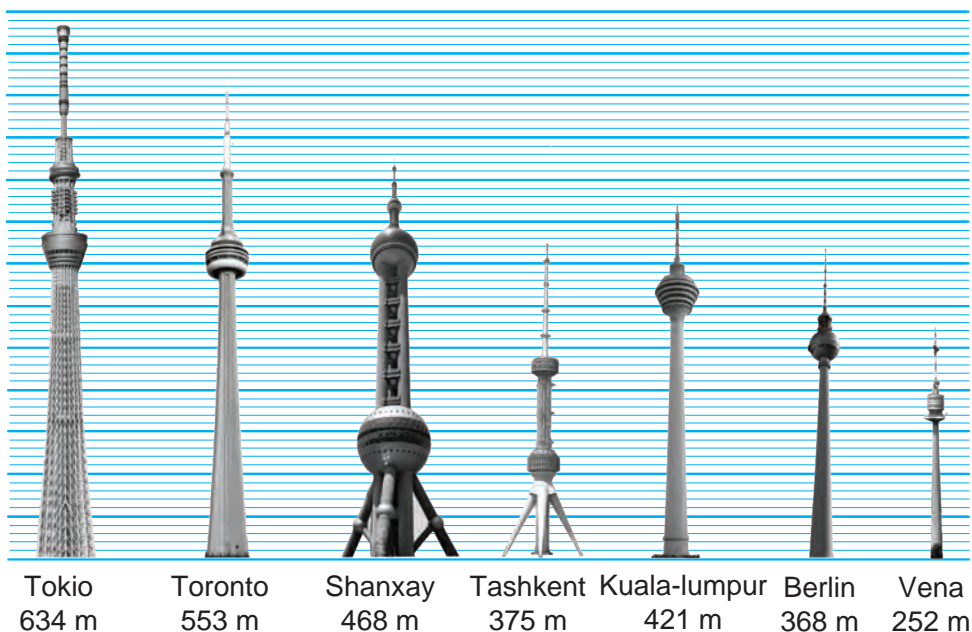

10- su'wret

Qi'zi'qli' matematikag'a tiyisli ma'seleler



Boyi'n'izdi' o'lshep bari'n'! (A'meliy jumi's)

Uzi'nli'g'i' 2 m bolg'an jabi'sqaq aq ren'li lenta (da'rixanada sati'latug'i'n leykoplaster) ali'n'. Lentani' bir ushi' polg'a tiyetug'i'n etip, esik ramasi'na tik halatta jabi'sti'ri'n'. Og'an bo'limleri 1 sm bolg'an shkala si'zi'n'. (Eger lenta tabi'lmasa shkalani' suli'w etip esik ramasi'na tik etip si'zi'w mu'mkin). Shkala qasi'nda tik turi'p, o'zin'izdin' ha'm basqa shan'araq ag'zalari'ni'n' boyi'n' o'lshen'. Eger ha'r sapar boyi'n'izdi' shkalada belgilep qasi'na sa'neni de jazi'p barsan'iz, ji'llar dawami'nda qansha o'skenin'izdi bilip barassz.

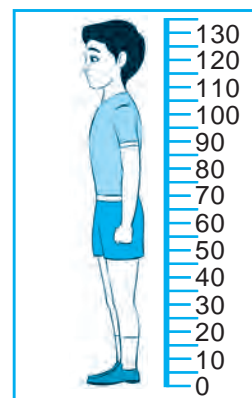

5-§.

NATURAL SANLARDI' SALI'STI'RI'W, U'LKEN YAMASA KISHI

5.1. Natural sanlardi' sanlar nuri'nda sali'sti'ri'w

Yeki tu'rtli natural sanlardi' sali'sti'ri'w degende, wolardan qaysi' biri u'lken yamasa kishi yekenligin ani'qlawg'a ayti'ladi'. Sanlar nuri' natural sanlardi' sali'sti'ri'w ushi'n ju'da' qolay keledi (1-su'wret).

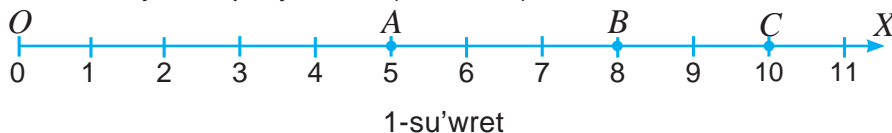

Yeki natural sannan qaysi' biri sanlar nuri'nda shepte jaylasqan bolsa, sol san kishi boladi'. Kerisinshe, qaysi' biri won'da jaylasqan bolsa, sol san u'lken boladi.

Sanlardi' sali'sti'ri'w na'tiyjesi ten'sizlik ko'rinishinde, u'lken (>) yamasa kishi (<) belgileri ja'rdeminde jazi'ladi'. 1-su'wrette $5 < 8$, sebebi sanlar nuri'nda $A(5)$ noqati $B(8)$ noqati'na qarag'anda shepte jaylasqan.

8 sani' 5 ten u'lken, biraq 10 sani'nan kishi. Bul belgiler ja'rdeminde $5 < 8 < 10$ qos ten'sizlik ko'rinishinde jazi'ladi'.

5.2. Tu'rtli xanali' sanlardi' sali'sti'ri'w

Ko'p qanali' sanlardi' to'mendegishe sali'sti'ri'w mu'mkin:

$$\begin{array}{c} \underline{5612} > \underline{963} \\ 4 \text{ qanali'} & 3 \text{ qanali'} \end{array}$$

Sebebi, birinshi san to'rt qanal', yekinshi san bolsa u'sh qanal' ($4 > 3$).



Ha'r qi'yli' qanali' sanlardi' wo'z-ara sali'sti'rg'anda qaysi' birinin' xanalari' ko'p bolsa, soni'si' u'lken boladi'.

5.3. Birdey qanali' sanlardi' sali'sti'ri'w

a) $\underline{8}512 > \underline{3}925$. Sebebi, ha'r yeki san to'rt qanali'. Birinshi sannin' mi'n'li'qlar xanasi'ndag'i' 8 cifri', yekinshi sannin' mi'n'li'qlar xanasi'ndag'i' 3 cifri'nan u'lken ($8 > 3$).

b) $\underline{38}42 > \underline{36}18$. Sebebi, ha'r yeki san to'rt qanali' ha'm wolardi'n' mi'n'li'qlar xanasi'ndag'i' cifrlari' birdey 3 ke ten' bolsa da, birinshi sannin' ju'zlikler xanasi'ndag'i' 8 cifri' yekinshi sannin' ju'zlikler xanasi'ndag'i' 6 cifri'nan u'lken ($8 > 6$).

d) $65 \underline{437} > 65 \underline{432}$. Sebebi, ha'r yeki sannin' birlikler xanasi'nan basqa barli'q qanalari'ndag'i' cifrlari' wo'z-ara ten'. Biraq, birinshi sannin' birlikler xanasi'ndag'i' 7 cifri', yekinshi sannin' birlikler xanasi'ndag'i' 2 cifri'nan u'lken ($7 > 2$).

Sanlardan birin yekinshisinin' asti'na sa'ykes qana birliklerindeki cifrlari' u'stpe-u'st tu'setug'i'n yetip jazi'lsa, sali'sti'ri'w protsesi an'satlasadi'. Ha'qiyqattan da:

$$\begin{array}{r} 8 \ 6 \ 5 \ 2 \ \underline{6}8 \\ 8 \ 6 \ 5 \ 2 \ \underline{3}1 \end{array}$$

$8=8, 6=6, 5=5, 2=2, 6 > 3$. Demek, $865268 > 865231$.

Birdey qanali' sanlardi' wo'z-ara sali'sti'ri'wda, wolardi'n' shep ta'repinen baslap bir qi'yli' atamadag'i' xanalar'i'nda turg'an cifrlardi' wo'z-ara sali'sti'ri'p shi'g'i'w jetkilikli.



Kesindilerdi sali'sti'ri'w na'tiyjesi' ha'm u'lken ($>$) yamasa kishi ($<$) belgileri ja'rdeminde jazi'ladi'. AB kesindinin' CD kesindiden qi'sqali'g'i' $AB < CD$, MN kesindinin' KL kesindiden uzi'n yekenligi belgili bolsa $MN > KL$ tu'rinde jazi'ladi'.

Sorawlarg'a juwap berin'!



1. Yeki sandi' sali'sti'ri'w degende ne tu'siniledi?
2. Sanlar nuri'nda yeki natural san qalay sali'sti'ri'ladi'?
3. Bes xanali' san u'lkenbe yamasa jети xanali' sanba? Ne ushi'n?
4. Ha'r qi'yli' xanali' sanlar qalay sali'sti'ri'ladi'?
5. Birdey xanali' sanlar qalay sali'sti'ri'ladi'?

Klasta wori'nlanatug'i'n shi'ni'g'i'wlar



97. A ha'm B noqatlari'ni'n' qaysi' biri sanlar nuri'nda shepte jaylasqan?
a) A (1) ha'm B (8); b) A (17) ha'm B (38); d) A (583) ha'm B (539).

98. a) 18 ha'm 27; b) 2090 ha'm 2095 sanlari' arasi'ndag'i' barli'q natural sanlardi' ayti'n'.

99. Qo'sh tengsizlik ko'rinishida ifodalang:

- a) 20 sani' 10 sani'nan u'lken, biraq 30 sani'nan kishi;
- b) 44 sani' 55 sani'nan kishi, biraq 33 sani'nan u'lken;
- d) 32 sani' 43 sani'nan kishi, 43 sani' bolsa 54 sani'nan kishi.

100. Sanlar nuri'nda a) 10 nan kishi; b) 12 den u'lken, biraq 17 den kishi bolg'an barli'q natural sanlardi' an'lati'n'.



101. Ka'rim bir san woyladi'. Bul sanni'n' aqi'rg'i' cifri' 5 penen tamamlanadi' ha'm bul san 300 den u'lken, biraq 310 nan kishi. Bul san qaysi'?

102. To'mendegi yeki sannan qaysi' biri u'lken yekenligin ani'qlan' ha'm juwabi'n'i'zdi' da'slep " $>$ " belgisi menen, son' " $<$ " belgisi menen an'lati'n'. Payda bolg'an ten'sizlikni woqi'n'.

- a) 10 ha'm 18; b) 75 ha'm 79; d) 147 ha'm 170; e) 11 876 ha'm 11 765;
- f) 2 660 008 ha'm 2 665 001; g) 6 877 500 600 ha'm 6 876 999 999.

103. To'mendegi sanlardi'n' bazi' bir cifrlari'ni'n' worni'na juldizshalar qoyilg'an. Wo-lardan qaysi' biri u'lken yekenligin tabi'n' ha'm ten'sizlik ko'rinishinde an'lati'n':

- a) 87^{***} ha'm 86^{***} ;
- b) $*5^{***}$ ha'm $*8^{**}$.

104. To'mendegi sanli' ten'lik ha'm tensizliklerdin' qaysi'lari' duri's?

- a) $322 + 128 = 450$;
- b) $25 \cdot 22 = 5500$;
- d) $132 : 11 = 18 - 6$;
- e) $58 \cdot 65 = 15625 : 25$;
- f) $24 \cdot 28 < 625$;
- g) $1320 : 40 > 35$.



105. 114 ten u'lken, biraq 133 sani'nan kishi ha'mde aqi'rg'i' cifri' 3 penen tamamlanatug'i'n sandi' ani'qlan'.

106. Sanlardi' salisti'ri'n' ha'm juldizsha wo'rnina « $<$ » yamasa « $>$ » belgisin qo'yin':

- a) $456\ 500 * 49\ 900$;
- b) $36\ 106 * 36\ 099$;
- d) $77\ 417 * 8432$;
- e) $5\ 000 * 49\ 999$;
- f) $8\ 720\ 000 * 8\ 720\ 019$;
- g) $930\ 000 * 1\ 000\ 001$.

107. Su'wrettegi kesindiler uzi'nli'g'i'n si'zg'i'sh ja'rdemide wo'lshen' ha'm wolardi' wo'siw ta'rtibinde jazi'n'.

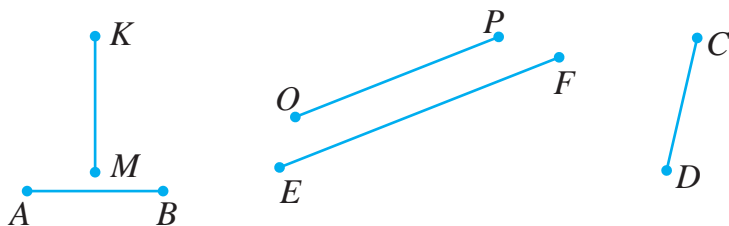

108. Su'wrette keltirilgen mag'li'wmatlardan paydalani'p A ha'm B noqatlardsh' koordinatalari'n tabi'n'.



109. Muzqaymaqtin' bahasi' 1500 swm. Mahmud 5000 swmg'a usi' muzqaymaq-tan a) yeki; b) u'sh; d) to'rt muzqaymaq sati'p ali'wi' mu'mkinbe?

110. Su'wretke qarata ma'sele du'zin' ha'm woni' sheshin'.

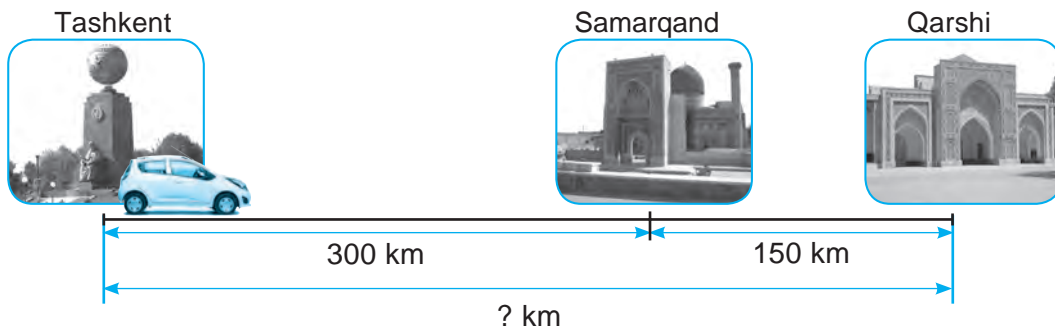

U'yde wori'nlanatug'i'n ma'seleler

111. Sanlar nuri'nda A ha'm B noqatlardi'n' qaysi' biri sol jaqta jatadi'?
- a) $A(5)$ yamasa $B(3)$; b) $A(47)$ yamasa $B(82)$; d) $A(557)$ yamasa $B(735)$.
112. Qos ten'sizlik ko'riniside an'lati'n':
- a) 10 sani' 8 sani'nan u'lken, biraq 23 sani'nan kishi;
- b) 75 sani' 93 sani'nan kishi, biraq 57 sani'nan u'lken;
- d) 42 sani' 65 sani'nan kishi, 65 sani' bolsa 87 sani'nan kishi.
113. Sanlar nuri'nda a) 7 den kishi; b) 15 den u'lken, biraq 22 den kishi bolg'an barli'q sanlardi' ko'rsetin'.
114. To'mendegi sanlardi' sali'stiri'n', ha'mde juldizsha worni'na " $<$ " yamasa " $>$ " belgisin qoyi'n'.
- a) $600\ 080 * 609\ 900$; b) $43\ 006 * 43\ 007$; d) $91\ 453 * 91\ 811$;
- e) $80\ 000 * 79\ 999$; f) $1\ 039\ 000 * 1\ 034\ 099$; g) $5\ 000\ 009 * 5\ 000\ 010$.

6-§.

I BAPTI' TA'KRARLAWG'A BAYLANI'SLI' MA'SELELER

6.1. A'meliy shi'ni'g'i'w: Kesteler ha'm mag'li'wmatlar menen islew

Siz kesteler menen aldi'nan tani'ssi'z. Ku'ndelik da'pterin'iz, klass jurnali', na'wbetshiler dizimi – kestelerge mi'sal bola aladi'. Keste du'ziwden maqset, qandayda bir temag'a tiyisli mag'li'wmatlardi' ta'rtipke sali'wdan ha'm wolardan paydalani'wdi' an'satlasti'ri'wdan ibarat.

1-mi'sal. Woqi'wshi' jan'a woqi'w ji'li' aldi'nan du'ka'nnan bahasi' 7000 swm bolg'an bir sumka, bahasi' 400 swm bolg'an 20 da'pter, ha'r biri 200 swm bolg'an 3 rushka, bahasi' 1200 swm bolg'an 2 ren'li qa'lemler toplami'n sati'p aldi'.

Bul mag'li'wmatlar tiykari'nda keste du'zin'. Kestede ha'r bir woqi'w qurali'ni'n' bahasi', mug'dari', ma'nisi ha'm ja'mi woqi'w qurallari' ushi'n neshe swm sari'plag'ani' ko'rinsin.

Sheshiliwi: Kestenin' bag'analari'na at qoyi'p shi'g'ami'z. Birinshi bag'anag'a ta'rtip nomeri, yekinshi bag'anag'a “Woqi'w qurallari' atlari'” ha'm keyingi bag'analarg'a “Bir danasi'ni'n' bahasi'”, “Mug'dari'” ha'm “Ma'nisi” dep jazip qoyami'z. Sonnan son', berilgen mag'li'wmatlardan paydalani'p kesteni tolti'rami'z. Aqi'rg'i' qatarg'a bolsa, “Ja'mi to'lengen pul”, degen so'zlerdi jazip qoyami'z.

№	Woqi'w qurallari' atlari'	Bir danasi'ni'n' bahasi'	Mug'dari' (sani')	Ma'nisii
1.	Sumka	7 000	1	
2.	Da'pter	400	20	
3.	Rushka	200	3	
4.	Ren'li qa'lemler	1 200	2	
	Ja'mi to'lengen pul	–	–	

Kestenin' aqi'rg'i' bag'anasi'n tolti'ri'w ushi'n, ha'r bir qatardag'i' woqi'w qurallari'ni'n' bir danasi'ni'n' bahasi'n, wolardi'n' mug'dari'na ko'beytip, usi' qatardi'n' aqi'rg'i' bag'anasi'na jazami'z. Buni'n' menen ha'r bir woqi'w qurali'na ja'mi neshe swm to'lengenin tabami'z. Son' bolsa aqi'rg'i' bag'anadag'i' barli'q sanlardi' qosi'p, qosi'ndi'ni' aqi'rg'i' bag'anani'n' aqi'rg'i' qatari' menen kesilisiw jerine jazami'z. Bul san woqi'w qurallari' ushi'n to'lengen ja'mi puldi'n' mug'dari'n bildiredi.

№	Woqi'w qurallari' atlari'	Bir danasi'ni'n' bahasi'	Mug'dari' (sani')	Ma'nisi
1.	Sumka	7000	1	7 000
2.	Da'pter	400	20	8 000
3.	Ruchka	200	3	600
4.	Rangli qalamlar	1200	2	2 400
	Jami to'lengen pul	–	–	18 000

119. To'mendegi kestdede berilgen mag'li'wmatlardan paydalani'p, bir ha'pte dawami'nda supermarket bo'limlarini' ha'r birine kelip tu'sken tovarlardi'n' uli'wma bahasi'n yesaplan'. Tap usi' yesap-sanaqti' pu'tkil supermarket boyi'nsha da wori'nlan'.

Ha'pte ku'nleri	Bo'limlar			Ja'mi supermarket - boyi'nsha
	Kiyim-kenshek	Ayaq kiyim	Gezlemeler	
Du'yshembi	6 500 000	4 500 000	3 300 000	
Seyshembi	8 600 000	5 110 000	4 400 000	
Sa'rshembi	13 200 000	8 020 000	5 100 000	
Piyshembi	8 700 000	3 600 000	7 100 000	
Juma	10 860 000	9 870 000	6 520 000	
Shembi	9 800 000	5 640 000	3 820 000	
Jami:				

120. Kesteni toltiri'n':

1-qosi'li'wshi'	450		11239
2-qosi'li'wshi'	409	13428	
qosi'ndi'		234581	987111

121. Kestede mebel fabrikasi'ni'n' yanvar, fevral, mart aylari'nda islep shi'g'arg'an wo'nimlarini' bahalari' (swmda) ko'rsetilgen. Kestenin' bos ketekshelerin toltiri'n'.

Wo'nimlar	Yanvar	Fevral	Mart	Jami
Stullar	1 567 800		1 594 900	4 641 800
Stollar	2 910 500	2 801 600		
Shkaflar	145 280		1 471 000	
Ja'mi:		5 655 900		17 652 000

122. To'mendegi kestdede u'sh jumi's ishewshinin' birinshi yari'm ayli'q is haqilari' (swmda) ko'rsetilgen. Ha'r bir ay boyi'nsha qaysi'si ko'birek is haqi' alg'an? Yari'm ji'lda she? U'shewi birgelikte qaysi' ayda en' ko'p is haqi' alg'an?

	yanvar	fevral	mart	aprel	may	iyun	Jami:
1-jumi'sshi'	468 000	489 300	439 100	301 800	522 300	467 500	
2-jumi'sshi'	352 800	432 100	442 300	412 300	534 500	448 100	
3-jumi'sshi'	293 600	395 700	411 800	399 100	445 000	470 000	
Jami:							

123. Sanlardi' woqi'n'.

- a) 112 657 209 045;
d) 45 670 888 009;

- b) 62 000 77;
e) 621 600 670 099.

124. AB kesindisin C noqati' AC ha'm CB bo'leklerge ajratadi'. Yeger AC kesindinin' uzi'nli'g'i' 79 sm boli'p, wol CB kesindiden 45 sm uzi'n bolsa, AB kesindinin' uzi'nli'g'i'n' tabi'n'.
125. AB kesindini C ha'm D noqatlar izbe-iz kelgen AC , CD ha'm DB bo'leklerge ajratadi'. Yeger AC kesindinin' uzi'nli'g'i' 65 dm boli'p, wol CD kesindiden 30 dm qi'sqa, DB kesindi CD dan 42 dm uzi'n bolsa, AB kesindinin' uzi'nli'g'i'n' tabi'n'li'g'i'n' tabi'n'.
126. To'mendegi shkalalardi'n' bir bo'liminin' ma'nisin ani'qlan'.



127. Grammlarda an'lati'n':

- a) 5 kg 998 g; b) 7 kg 454 g; d) 8 ts 12 kg 881 g.

128. Tonna ha'm kilogrammlarda an'lati'n':

- a) 44 356 kg; b) 70096 kg; d) 1000032 kg; e) 860221 kg.

129. Santimetrlerde an'lati'n':

- a) 21 dm 9 sm b) 12 dm 5 sm; d) 34 dm 2 sm; e) 102 dm 7 sm.

130. Santimetr ha'm millimetrlerde an'lati'n':

- a) 540 mm; b) 887 mm; d) 324 mm; e) 1297 mm.

131. Ko'pmu'yeshliklerdi da'pterin'izge si'zi'n' ha'm belgilen'. Si'zgi'sh ja'r-deminde wolardi'n' ta'replerinin' uzi'nli'qlari'n mm de wo'lshen' ha'm perimetrin tabi'n'.

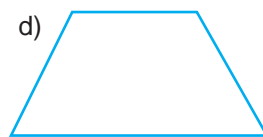
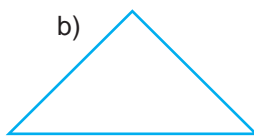
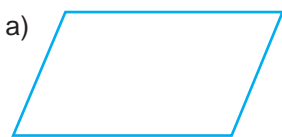

132. AB kesindisinin' uzi'nli'g'i' 112 sm ge ten'. Belgisiz kesindinin' uzi'nli'g'i'n' tabi'n'.



133. To'mendegi sanlardi' sali'sti'ri'n' ha'm de juldi'zshani'n' worni'na "<" yamasa ">" belgisin qoyi'n'.

- a) $556\,500 * 59\,900$; e) $6\,590\,000 * 6\,590\,019$;

b) $41\ 106 \cdot 41\ 099$;

f) $2\ 990\ 000 \cdot 21\ 000\ 001$;

d) $8\ 000 \cdot 79\ 999$;

g) $81\ 320\ 000 \cdot 81\ 316\ 999$.

134. Su'wrette berilgen mag'li'wmattan paydalani'p sanlar nuri'nda A ha'm B noqatlari'ni'n' koordinatasi'n tabi'n'.

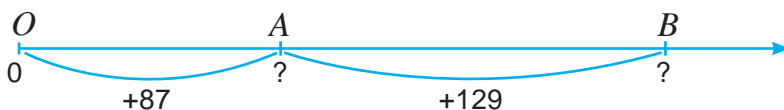

Bilimin'izdi si'nap ko'rin'!



Bul bap'tin' materialлари'n u'yrenip shi'g'i'p, to'mendegi ma'selelerdi sheshe ali'wi'n'i'z sha'rt! Qadag'alaw jumi'si' aldi'nan wo'zin'izdi si'nap ko'rin'!

Test. Duri's juwapti' ani'qlan'.

- Yeki million bes ju'z alti' mi'n' u'sh ju'z jetpis jeti sani' neshe qanali'?
 A. Alti'; B. Bes; D. Jeti; E. Segiz;
- Ha'r qanday yeki noqattan neshe tuwri' si'zi'q wo'tkeriw mu'mkin?
 A. Yeki; B. Bir; D. U'sh; E. Qa'legenshe;
- Sonlar nurida 23, 12, 19 va 35 sonlaridan qaysi biri eng chapda joylashgan?
 A. 23; B. 12; D. 19; E. 35;

1- qadag'alaw jumi's u'lgisi

- Sanlardi' sali'sti'ri'n' ha'm juwapti' "<" yamasa ">" belgileri ja'rdeminde jazi'n':
 a) $2\ 657\ 209$ ha'm $2\ 654\ 879$; b) $96\ 785$ ha'm $354\ 211$.
- MN tuwri' si'zi'q ha'm CD nuri'n sonday yetip si'zi'n', wolar kesilispesin.
- Cifrlar menen jazi'n': u'sh ju'z bes million segiz mi'n' alti'.
- a) sanlar nuri'nda A, F, K, O noqatlari'ni'n' koordinatalari'n jazi'n':



- b) da'pter keteshesi yenin birlik kesindi si'pati'nda ali'p, sanlar nuri'nda $B(8), D(11), P(1), R(16)$ noqatlari'n belgilen'.
- 9987 den u'lken ha'm 6 cifri' menen tamamlanaturg'i'n to'rt qanali' sandi' jazi'n'.

II BAP. NATURAL SANLARDI' QOSI'W HA'M ALI'W

7-§. NATURAL SANLARDI' QOSI'W HA'M WONI'N' QA'SIYETLARI

7.1. Natural sanlardi' qosi'w

Maydandshada 4 jari's mashinasi' turg'an yedi. Wolarg'a izbe-iz ja'ne 3 mashina kelip qosi'ldi' (1- su'wret). Maydandshada ja'mi neshe jari's mashinasi' boldi'?

Bul ma'seleni sheshiw ushi'n avtomobillerdi sanap shi'g'i'w jeterli:

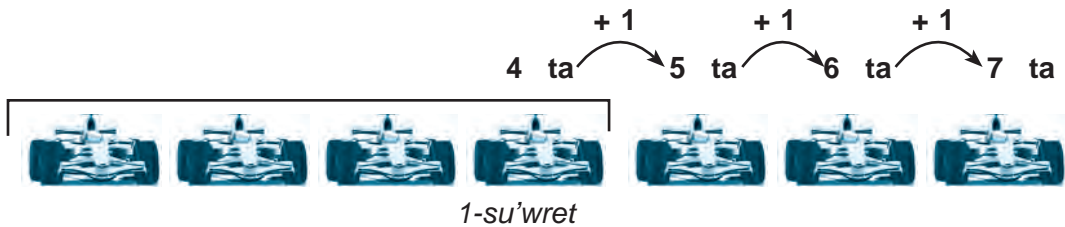

Demek, 4 ke 3 ti qosi'w – 4 sani'na 3 ma'rte 1 di qosi'w degeni:

$$4 + 3 = 4 + 1 + 1 + 1 = 5 + 1 + 1 = 6 + 1 = 7.$$

Bu qi'sqasha $4 + 3 = 7$ tu'rinde jazi'ladi'.

Bir-birine qosi'latug'i'n sanlar – *qosi'li'wshi'lar*, qosi'w na'tiyjesi bolsa *qosi'ndi'* deb ataladi.

$$\overbrace{18 + 37}^{qosi'ndi'} = \overbrace{55}^{qosi'ndi'}$$

1- qosi'li'wshi' 2- qosi'li'wshi'

Sanlardi' qosi'wdi' sanlar nuri'nda ko'rsetiw mu'mkin (1–su'wret). $A(4)$ noqati'nan won' ta'repke qarap u'sh birlik kesindini sanaymi'z ha'm $B(7)$ noqati'n tabami'z.

Demek, $4 + 3 = 7$.

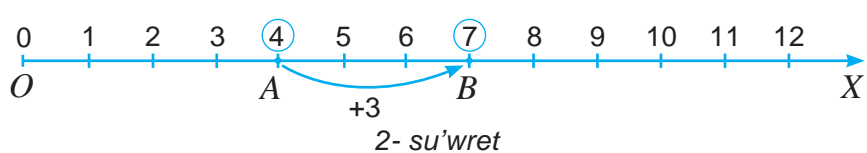

7.2. Natural sanlardi' qosi'wdi'n' qa'siyetleri

Qosi'w a'melinin' bir neshe qa'siyetlerin keltiremiz:

Qosi'li'wshi'lardi'n' worni'n almasti'ri'lg'ani' menen qosi'ndi' wo'zgermeydi. 

1-mi'sal: $6 + 3 = 9$ ha'm $3 + 6 = 9$ sebebi: $6 + 3 = 3 + 6$.

Qosi'wdi'n' bul qa'siyeti *qosi'wdi'n' wori'n almasti'ri'w ni'zami'* dep ataladi'.

Bir neshe qosi'li'wshi'lar qosi'ndi'si' bul qosi'li'wshi'lardi'n' qaysi' ta'rtipte qosi'li'wi'na baylani'sli' yemes. 

2-mi'sal: 21, 14 ha'm 45 sanlarini'n' qosi'ndi'si'n yesaplan'.

Qosi'ndi'ni' yeki tu'rli usi'l menen yesaplaw mu'mkin:

1) aldi'n 21 + 14 sanlari'ni'n' qosi'ndi'si'n tawi'p, wog'an 45 sani'n qosami'z:

$$(21+14) + 45 = 35 + 45 = 80;$$

2) aldi'n 14 ha'm 45 sanlari'ni'n' qosi'ndi'si'n tawi'p, wog'an 21 di qosami'z:

$$21 + (14 + 45) = 21 + 59 = 80.$$

Ko'rip turg'ani'n'i'zday, natiyje bir qi'yli', yag'ni'y bulu'sh sanni'n' qosi'ndi'si', wolardin' qaysi' ta'rtipte qosi'li'wi'na baylani'sli' yemes.

Qosi'wdi'n' bul qa'siyeti *qosi'wdi'n' gruppaw ni'zami'* dep ataladi'.

Bunnan bir neshe sanlardi' qosi'p ati'rg'anda, qosi'ndi'da wolardi'n' worni'n qa'legenshe almasti'ri'p jazi'w ya'ki wolardi' qawi'slar ja'rdeminde qa'legen ta'rtipte gruppaw mu'mkinligi kelip shig'adi:

$$54 + 67 + 31 + 79 = 67 + 79 + 54 + 31,$$

$$54 + 67 + 31 + 79 = (54 + 67) + (31 + 79).$$

Soni'n' menen birge, a'dette $(4 + 7) + 3$ worni'na $4 + 7 + 3$ jazi'ladi'. Yeger jazi'wda qawi'slar qatnaspag'an bolsa, qosi'w soldan won'g'a qarap izbe-iz wori'nlanadi'.

Qosi'wdi'n' gruppaw ni'zami'nan sanlar qosi'ndi'si'n qolayli' usi'l menen yesaplawda da paydalani'w mu'mkin.

3-mi'sal: Qosi'ndi'ni' qolayli' usi'l menen yesaplan': $54 + 39 + 78 + 46 + 61$.

Qosi'wdi'n' gruppaw ni'zami'nan paydalani'p, sanlardi' qosi'wg'a qolayli' yetip to'mendegishe gruppalaymiz ha'm qosi'ndi'ni' tabami'z:

$$54 + 39 + 78 + 46 + 61 = (54 + 46) + (39 + 61) + 78 = 100 + 100 + 78 = 278.$$

Yeki qosi'li'wshi'dan biri no'l bolsa, qosi'ndi' yekinshi qosi'li'wshi'g'a ten' boladi'. 

4-mi'sal: $6 + 0 = 0 + 6 = 6$.

Ha'r qanday natural sandi' woni'n xana qosi'li'wshi'lari'ni'n' qosi'ndi'si' tu'rinde su'wretlew mu'mkin. 

5-mi'sal: 778135 sani'n to'mendegi xana qosi'li'wshi'lari'ni'n' qosi'ndi'si' tu'rinde jazi'w mu'mkin:

$$78\ 135 = 7\ 0\ 0\ 0\ 0 + 8\ 0\ 0\ 0 + 1\ 0\ 0 + 3\ 0 + 5$$

ya'ki $78\ 135 = 7 \cdot 10\ 000 + 8 \cdot 1000 + 1 \cdot 100 + 3 \cdot 10 + 5 \cdot 1$

Bul ten'likten ko'p qanali' sanlardi' bag'ana tu'rinde qosi'wda paydalani'ladi'.

6-mi'sal: 345 ha'm 621 sanlari'ni'n' qosi'ndi'si'n tabi'n.

Aldi'n ha'r bir sandi' woni'n' xana qosi'li'wshi'lari' qo'si'ndi'si' ko'riniside su'wretleyemiz, son' mas xana birliklerin gruppalap qosi'p shig'ami'z:

		345
+	621	
		966

$$345 + 621 = (300 + 40 + 5) + (600 + 20 + 1) = (300 + 600) + (40 + 20) + (5 + 1) = 966.$$

Sanlardi' «u'stin ko'riniside qosi'w» usi'li' joqari'dag'i' yesaplawlarg'a tiykarlang'an.



Sorawlarg'a juwap berin'!

1. 5 sani'na 4 sani'n qosi'w degende neni tu'sinesiz?
2. Qosi'w a'melinin' na'tiyjesi ne dep ataladi'?
3. Qosi'wdi'n' wori'n almasti'ri'w ni'zami'n sanlar nuri'nda tu'sindirip berin'.
4. Sang'a nol qosi'lsa, qosi'ndi' nege ten' boladi'?
5. Natural san xana qosi'li'wshi'lari'ni'n' qosi'ndi'si' tu'rinde qalay su'wretlenedi'?



Klasta wori'nlanatug'i'n shi'ni'g'i'wlar

135. Sanlar nuri'nda $A(8)$ noqati'n ha'm wonnan 7 birlik won'g'a B noqati'n belgilen' Sanlar nuri'nda B noqati'ni'n' koordinatasi' neshege ten' boladi'?

136. $77 + 23$ qosi'ndi'si'n yesaplan'. 100 sani'n payda yetiw ushi'n 77 ge neshe birdi qosi'w kerek?

137. Yesaplan':

- a) $7\ 012 + 50\ 367$; b) $70\ 046 + 48\ 992$; d) $27\ 330 + 1\ 360$;
 e) $3\ 485 + 2\ 7341$; f) $50\ 022 + 64\ 502$; g) $977\ 200 + 127\ 033$.

138. Sanlardi'n' qosi'ndi'si'n tabi'n':

- a) 522, 44, 8 904; b) 709, 234, 2 064;
 d) 5 089, 444, 2 100, 209; e) 40 511, 38 872, 294, 77 062;

139. To'mendegi kestede mebel favrikasi'ni'ni'n' da'ra'ma'ti' (swmda) ko'rsetilgen. Kestenin' bos ketekshelerin tolti'ri'n'. Yeger barli'q a'mellerdi duri's wori'nlasan'i'z aqi'rg'i' qatar ha'm aqi'rg'i' bag'anadag'i' sanlar qosi'ndi'si' ten' shi'g'i'wi' kerek.

Wo'nim	Yanvar	Fevral	Mart	Jami:
Stol	1 576 400	1 465 400	1 798 500	
Stul	2 951 500	2 871 400	2 764 800	
Shkaf	1 479 500	1 332 100	1 574 800	
Jami:				

140. A qaladan B qalag'a qanday jollar menen bari'w mu'mkinligin ani'qlan'. Ha'r bir joldi'n' uzi'nli'g'i'n tabi'n' ha'm yen' qi'sqa joldi' ani'qlan'.

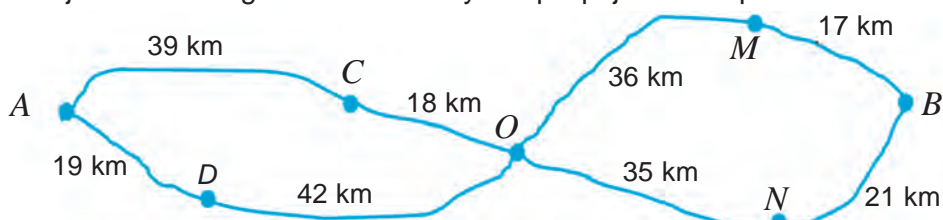

U'lgi: Jollardi'n' biri ($A-C-O-M-B$)nin' uzi'nli'g'i'i: $39+18+36+17=110$ (km) ge ten'.

141. A'ziz bazardan 2 kg kartoshka, 3 kg la'blebi, 5 kg geshir, 4 kg alma, 5 kg kapusta, 2 kg almurt ha'm 3 kg qa'reli sati'p aldi' ha'm wol neshe kg miywe ha'm pali'z eginlerin sati'p alg'an?

142. Qosi'ndi'ni' tabi'n':

- a) $4 \cdot 10000 + 2 \cdot 1000 + 1 \cdot 100 + 9 \cdot 10 + 3 \cdot 1$;
 b) $4\ 000\ 000 + 200\ 000 + 80\ 000 + 1\ 000 + 400 + 80 + 7$;
 d) $700\ 000 + 30\ 000 + 200 + 40 + 3$;

U'lgi: a) $4 \cdot 10\ 000 + 2 \cdot 1000 + 1 \cdot 100 + 9 \cdot 10 + 3 \cdot 1$ an'latpasi sani'ni'n' xana qosi'li'wshi'lari' qosi'ndi'si'nan ibarat. Soni'n' ushi'n berilgen qosi'ndi' 42 193 ge ten'.

143. Fermer xojali'g'i'nda birinshi ku'ni 125 t, yekinshi ku'ni birinshi ku'nnen 42 t ko'p kartoshka terip ali'ndi'. U'shinshi ku'ni bolsa yekinshi ku'nnen 28 t ko'p kartoshka terip ali'ndi'. Ush ku'nde ja'mi neshe tonna kartoshka terip ali'ndi'?

144. Avtomobildin joldi' yesaplag'i'shi' qanday sandi' ko'rsetedi?

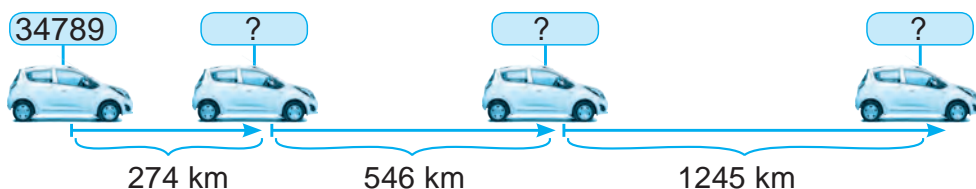

145. Qosi'li'wshi'lardi' bir-birin «qolayli'» sang'a tolti'ratug'i'n gruppalarg'a aji-rati'p, qosi'ndi'ni' yesaplan'.

- a) $3 + 3 + 7 + 8 + 2 + 7 + 9 + 1$; b) $15 + 24 + 23 + 15 + 26 + 37 + 78 + 12$;
U'lgi: $4 + 8 + 6 + 2 = (4 + 6) + (8 + 2) = 10 + 10 = 20$.

146. Qosi'wdi'n' gruppalar ni'zami'n qollani'p qosi'ndi'ni' yesaplan':

- a) $(6347 + 3747) + 6253$; b) $9999 + (4701 + 20\ 200)$;
 d) $(44\ 888 + 69\ 999) + 10\ 001$; e) $18\ 856 + (1544 + 3322)$.

U'lgi: a) $(6347 + 3747) + 6253 = 6347 + (3747 + 6253) = 6347 + 10\ 000 = 16347$.

147. Qosi'ndi'ni' qolayli' usi'lda yesaplan':

- a) $325 + 484 + 675$; e) $448 + 323 + 52 + 77$;
 b) $321 + 337 + 363$; f) $123 + 978 + 277 + 22$;
 d) $234 + 456 + 166$; g) $511 + 245 + 855 + 89$.

U'lgi: a) $325 + 484 + 675 = (325 + 675) + 484 = 1000 + 484 = 1484$.

148. ABC u'shmu'yeshliginin' AB ta'repi BC ta'repten 4 sm qi'sqa ha'm AC ta'repten bolsa 3 sm uzi'n. Yeger $AC = 17$ sm yekenligi belgili bolsa, ABC u'shmu'yeshliginin' perimetrin yesaplan'.

149. Qosi'ndi'ni' qolayli' usi'lda yesaplan':

- a) $11 + 12 + 13 + 14 + 15 + 16 + 17 + 18 + 19 + 20$;
 b) $23 + 25 + 27 + 29 + 31 + 33 + 35 + 37$;
 d) $5 + 10 + 15 + 20 + \dots + 100$;
 e) $94 + 84 + 74 + \dots + 24 + 14 + 4$.

U'lg'i: a) $11 + 12 + 13 + 14 + 15 + 16 + 17 + 18 + 19 + 20 =$

$$= (11 + 20) + (12 + 19) + (13 + 18) + (14 + 17) + (15 + 16) =$$

$$= 31 + 31 + 31 + 31 + 31 = 31 \cdot 5 = 155.$$



U'yde wori'nlanatug'i'n ma'seleler

150. Sanlar nuri'nda $M(6)$ noqati'n ha'm wonnan 8 birlik won'da N noqati'n belgilen' Sanlar nuri'nda N noqati'ni'n' koordinatasi' neshege ten' boladi'?

151. Yesaplan':

a) $2570 + 47\ 534;$

b) $67\ 423 + 24\ 137;$

d) $26507 + 1760;$

e) $8534 + 34\ 271;$

f) $51\ 700 + 9760;$

g) $39\ 523 + 6670.$

152. Sanlardi'n' qosi'ndi'si'n tabi'n':

a) 102, 56, 1324;

b) 650, 17, 2333;

d) 1003, 467, 85;

e) 449, 257, 134, 112;

f) 435, 6027, 239, 2123;

g) 260, 35070, 6306, 32.

153. Su'wrette ko'rsetilgen gilttin'uzi'ni'g'i'n ani'qlan'.



154. Asi'lbek ha'm Shohrux pomidor terdi. Asi'lbek 12 kg 750 g, Shohrux bolsa Asi'lбектен 8 kg 500 g ko'birek pomidor terdi. Wolar ja'mi qanshkg pomidor terdi?

155. Yig'indini toping:

a) $7 \cdot 10000 + 4 \cdot 1000 + 3 \cdot 100 + 4 \cdot 10 + 7 \cdot 1;$

b) $1\ 000\ 000 + 500\ 000 + 60\ 000 + 3\ 000 + 200 + 90 + 5;$

d) $600\ 000 + 6\ 000 + 700 + 30 + 1.$

156. Fermer xojali'g'i'nda birinshi ku'ni 342 t, yekinshi ku'ni birinshi ku'ndegiden 22 t ko'p piyaz terip ali'ndi'. U'shinshi ku'ni bolsa yekinshi ku'ndegiden 18 t ko'p piyaz terip ali'ndi'. U'sh ku'nde ja'mi neshe tonna piyaz terip ali'ndi'?



157. Qosi'li'wshi'lardi' bir-birin «qolayli'» sang'a tolti'ratug'i'n gruppalarg'a aji'rati'p, qosi'ndi'ni' yesaplan':

a) $16 + 21 + 13 + 24 + 19 + 27;$

b) $347 + 118 + 249 + 53 + 162 + 81.$

158. Qosi'wdi'n' gruppalaw ni'zami'n qollani'p qosi'ndi'ni' yesaplan':

a) $(374 + 712) + 626;$

b) $999 + (901 + 2200);$

d) $(3355 + 7777) + 2223.$

159. Qosi'ndi'ni' qolayli' usi'lda yesaplan':

a) $51 + 52 + 53 + 54 + 55 + 56 + 57 + 58;$

b) $122 + 124 + 126 + 128 + 130 + 132 + 134 + 136 + 138.$

8-§.

NATURAL SANLARDI' ALI'W HA'M WONI'N' QA'SI'YETLARI'

8.1. Natural sanlardi' ali'w

1- mi'sal. Shahzada kitapti'n' 48 betin woqi'g'annan keyin kitapti'n' ja'ne 24 beti woqi'lmay qaldi'. Kitap neshe betten ibarat?

Sheshiliwi. Ma'sele qosi'w a'meli ja'rdeminde sheshiledi: $48 + 24 = 72$.

Juwabi'. Kitap 72 betten ibarat.

Yendi basqa misaldi' qarayi'q.

2- mi'sal. Kitap 72 betten ibarat. Shahzada kitapti'n' 48 betin woqi'di'. Kitapti'n' ja'ne neshe beti woqi'lmay qaldi'?

Sheshiliwi. Sonday sandi' tabi'wi'mi'z kerek, wog'an 48 di qosqanda, 72 payda bolsi'n. Bunday san $- 24$, sebebi $48 + 24 = 72$.

Juwabi'. Kitapti'n' ja'ne 24 beti woqi'lmay qalg'an.

Bul jag'dayda 24 sani' 72 ha'm 48 *sanlari'ni'n' ayi'rmasi'* dep ataladi' ha'm $2 - 48$ tu'rinde an'lati'ladi'. Demek, $72 - 48 = 24$.

Qosi'ndi' ha'm bir qosi'li'wshi' boyi'nsha yekinshi qosi'li'wshi'ni' tabi'wg'a *ali'w a'meli* delinedi. Ali'natug'i'n san $- ali'ni'wshi'$, ali'ni'wshi' ali'natug'i'n san $- azayi'wshi'$ ha'm ali'w a'meli na'tiyjesi *ayi'rma* dep ataladi'.

$$\begin{array}{c} \text{ayi'rma} \\ \text{72} \quad - \quad \text{48} \quad = \quad \text{ayi'rma} \\ \text{azayi'wshi'} \quad \quad \text{alini'wshi'} \quad \quad \text{24} \end{array}$$

Natural sanlardi' ali'wda azayi'wshi' ali'ni'wshi'dan kishi boli'wi' mu'mkin yemes. 

Yeki sanni'n' ayi'rmasi' – birinshi sanni'n yekinshisinen *qanshag'a ko'p* yekenligin ya'ki yekinshi sanni'n birinshisinen *qanshag'a kem* yekenligin an'latadi'.

Natural sanlardi' ali'wdi' sanlar nuri'nda ko'rsetiw mu'mkin. Ma'selen, 8 sani'nan 5 sani'n ali'w talap yetilsin. Sanlar nuri'nda $A(8)$ noqati'n belgileyemiz (1-su'wret).

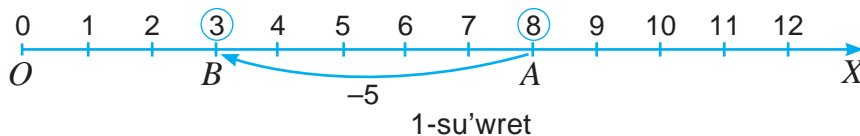

Won'nan shepke qarap 5 birlik kesindi sanaymi'z ha'm $B(3)$ noqatti' tabami'z. Demek, $8 - 5 = 3$.

Sanlar nuri'nda A ha'm B noqatlari' arasi'nda 5 birlik kesindi jaylasqan. Demek, A ha'm B *noqatlari' arasi'ndagi' arali'q* 5 ke ten' boladi'. Bul $AB = 5$ tu'rinde jazi'ladi'.

Yeger yeki noqatti'n' koordinatalari' berilgen bolsa, wonda wolar arasi'ndagi' arali'qti' tabi'w ushi'n noqatlar koordinatalari'ni'n' u'lkeninen kishisi ali'nadi', yag'ni'y

$$AB = 8 - 3 = 5.$$

8.2. Natural sanlardi' ali'wdi'n' qa'siyetleri

1. Sannan qosi'ndi'ni' ali'w qa'siyeti

1-mi'sal. Yesaplan': $314 - (114 + 77)$.

1-usil': $314 - (114 + 77) = 314 - 191 = 123$.

Bul a'mellerdi to'mendegi «sannan qosi'ndi'ni' ali'w» qa'siyetinen paydalani'p ta wori'nlaw.



Sannan qosi'ndi'ni' ali'w ushi'n sannan aldi'n birinshi qosi'li'wshi'ni' ali'w, son' ayi'rmadan yekinshi qosi'li'wshi'ni' ali'w jetkilikli.

2-usil': a) $314 - (114 + 77) = (314 - 114) - 77 = 200 - 77 = 123$.

b) $314 - (114 + 77) = (314 - 77) - 114 = 237 - 114 = 123$.

2. Qosi'ndi'dan sandi ali'w qa'siyeti

2-mi'sal. Yesaplan': $(374 + 231) - 174$.

1-usil': $(374 + 231) - 174 = 605 - 174 = 431$.

Bul a'mellerdi to'mendegi «qosi'ndi'dan sandi ali'w» qa'siyetinen paydalani'p ta wori'nlaw mu'mkin.



Qosi'ndi'dan sandi ali'w ushi'n sandi qosi'li'wshilardan birinen ali'p, payda bolg'an ayi'rmag'a yekinshi qosi'li'wshi'ni' qosi'p qoyi'w jetkilikli.

2-usil': $(374 + 231) - 174 = (374 - 174) + 231 = 431$.

A'llette, bul qa'siyetti qollaw ushi'n ayri'latug'i'n san qoshi'li'wshi'lardi'n' birinen u'lken bolmawi' kerek.

3. Ali'wda no'ldin' qa'siyetleri

3-mi'sal. $7 + 0 = 7$ bolsa, wonda, ali'w a'meli ma'nisine qaray, $7 - 0 = 7$ ha'm $7 - 7 = 0$ boladi'.

Demek, to'mendegi ali'wda no'ldin' qa'siyetleri wori'ni' boladi'.



Sannan nol ali'ng'anda ayirma usi' sannin' wo'zi boladi. Kemeyuwshi ha'm ayiriluvchi o'zara ten' bolsa, ayirma no'lge ten' bo'ladi'.



Sorawlarg'a juwap berin'!

1. Yeki sannin' ayi'rmasi' dep nege ayti'ladi'?
2. Azayi'wshi' ali'ni'wshi'dan kishi boli'wi' mu'mkin be?
3. Yeki sannin' ayi'rmasi' neni an'latadi'?
4. Sannan qosi'ndi'ni' ali'w qag'i'ydasin sanlar nuri'nda tu'sindirin'.



Klasta wori'nlanatug'i'n shi'ni'g'i'wlar

160. Sanlar nuri'nda $M(15)$ noqati'n belgilen' ha'm wonnan 7 birlik shepte T noqati'n belgilen'. T noqati'ni'n' sanlar nuri'ndagi' koordinatasi'n tabi'n'.

- 161.** Ali'wdi' worinlawg'a bolama? Ne ushi'n?
 a) $342 - 424$; b) $654 - 444$; d) $399 - 0$; e) $0 - 42$; f) $23\ 451 - 23\ 456$.
U'lgi: Ali'wdi' worinlawg'a ushi'n azayi'wshi' ali'ni'wshi'dan kishi bolmawi' kerek. a) jag'dayda $324 < 424$. Demek, ali'wdi' a'melge asi'ri'p bolmaydi'.
- 162.** Qosi'w a'meli ja'rdeminde to'mendegi ten'liklerdi tekserin':
 a) $2158 - 599 = 1559$; b) $2601 - 765 = 1836$; d) $10\ 032 - 2255 = 7777$;
 e) $11431 - 5316 = 6115$; f) $2201 - 345 = 1856$; g) $12\ 209 - 4533 = 7676$.
U'lgi: a) $1559 + 599 = 2158$. Demek, ten'lik duri's.
- 163.** Ali'wdi' wori'nlan' ha'm na'tiyjeni qosi'w a'meli menen tekserin':
 a) $1\ 584 - 239$; e) $65\ 432 - 12\ 345$;
 b) $4\ 000 - 798$; f) $18\ 644\ 538 - 7\ 974\ 683$;
 d) $75\ 319 - 8\ 642$; g) $200\ 000\ 000 - 88\ 748\ 345$.
- 164.** «Lasetti» avtomobili «Neksiya» avtomobilinen a) qanshag'a uzi'n?
 b) qanshag'a biyik? (1- su'wret).



1- su'wret



- 165.** Plastik kartochkada 125 500 swm bar yedi. Du'ka'nnan 25 950 swmli'q sawda a'melge asi'ri'ldi'. Kartochkada neshe swm pul qaldi'?
- 166.** Avtomobil 1050 km arali'qti' basi'p wo'tiwi kerek. Yeger wol birinshi ku'ni 685 km ju'rigen bolsa, ja'ne neshe km jol ju'riwi kerek?



- 167.** A ha'm B noqatlar arasi'ndag'i' arali'qti' tabi'n'.

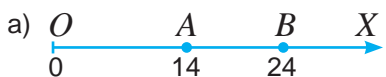

- 168.** Sanlar nuri'nda belgilengen noqatlardi'n' koordinatalari'n' tabi'n'. AB , BC , CA , BE ha'm DB kesindiler uzi'nli'g'i'n' yesaplan'.



- 169.** C noqati' AB kesindide jatadi'. Yeger $AB = 48$ sm ha'm $CB = 29$ sm yekenligi belgili bolsa, AC kesindisinin' uzi'nli'g'i'n' tabi'n'.
- 170.** 1 litr suwdi'n' massasi' 1 kg g'a ten'. 1 litr benzinnin' massasi' wodan 270 g kem. 1 litr benzinnin' massasi' qanshas?
- 171.** Bir saat dawami'nda birinshi robot (avtomatlasti'ri'lg'an u'skene) 1745, yekinshi robot bolsa 2100 detalga islew berdi. Yekinshi robot birinshisina qarag'anda qansha ko'p detalg'a islew bergeni?



172. Ali'w a'melinin' qa'siyetlerinen paydalani'p qolayli' usi'lda yesaplan':
 a) $(6\ 642 + 1\ 956) - 956$; b) $95\ 947 - (95\ 447 - 225)$;
 d) $(1\ 813 + 874) - 1\ 713$; e) $(7\ 563 + 1\ 437) - 999$.

U'lg'i: a) $(6642 + 1956) - 956 = 6642 + (1956 - 956) = 6642 + 1000 = 7642$.

173. A'mellerdi wori'nlan':

- a) $5478 - 4368 + 3479$; b) $5475 + 3011 - 1716$;
 d) $2789 + 3576 - 2428$; e) $7591 - 2439 + 3698$.

174. 2010-jil'li' du'nyada boyi' yen' uzi'n adam turkiyal'i'q 27 jasli' Sul-tan Kozen boli'p, woni'n' boyi' 2 m 46 sm, yen' kishkene adam bolsa Qi'tayli'q 20 jasli' Xi Ping Ping boli'p, woni'n' boyi' bar jog'i' 74 sm di quraydi' (2-su'wret). Sultan Xidan qansha uzi'n?

175. AB kesindisining' uzi'nli'g'i' 43 sm. C ha'm D noqatlari' AB ke-sindide jatadi'. D noqati' bolsa C ha'm B noqatlari'ni'n' ara-si'nda jatadi'. Yeger a) $AC = 15$ sm, $DB = 19$ sm; b) $AD = 28$ sm, $CB = 20$ sm bolsa, CD kesindisining' uzi'nli'g'i'n' tabi'n'?

176. $ABCD$ to'rtmu'yeshliktin' perimetri 100 sm. AB ta'repi 44 sm, BC ta'repi AB ta'repinen 15 sm qi'sqa, biraq CD ta'repten 8 sm uzi'n. AD ta'repinin' uzi'nli'g'i'n' tabi'n'.



2- rasm



U'yde wori'nlanatug'i'n ma'seleler

177. Sanlar nuri'nda $C(18)$ noqati'n belgilen' ha'm wonnan 9 birlik shepte D ha'm 5 birlik won'da E noqati'n belgilen'. D ha'm E noqatlari'ni'n' sanlar nuri'ndag'i' koordinatasi'n tabi'n'.

178. Ali'wdi' wori'nlan' ha'm na'tiyjeni qosi'w a'meli menen tekserin':

- a) $4\ 487 - 923$; b) $3\ 010 - 2318$; d) $19\ 334 - 15\ 722$.

179. «Kobalt» avtomobili «Lasetti» avtomobilinen a) qanshag'a qi'sqa? b) qanshag'a biyik? (3- su'wret).

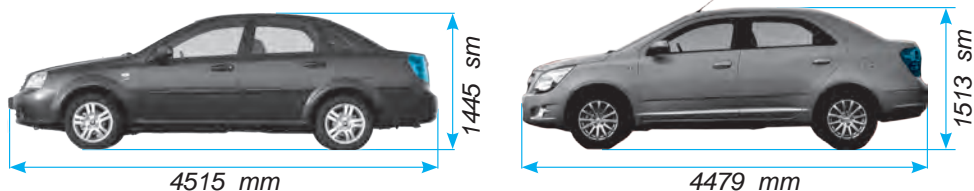

3- su'wret

180. Jirafati'n' boyi' 430 sm. Zebrani'n' boyi' bolsa wonnan 274 smge qi'sqa. Zebrani'n' boyi'n tabi'n'?



181. Sanlar nuri'nda belgilengen noqatlardi'n' koordinatalari'n ani'qlan'. a) A ha'm D ; b) C ha'm B lar arasi'ndag'i' arali'qti' tabi'n'.



182. C noqati' AB kesindisinde jataadi'. Yeger $AB = 24$ sm ha'm $CB = 15$ sm yekenligi belgili bolsa, AC kesindinin' uzi'nli'g'i'n tabi'n'.
183. Bir ha'ptede birinshi jumi'sshi' 1745, yekinshi jumi'sshi' bolsa 3421 detal jasaki'. Yekinshi jumi'sshi' birinshisine qarag'anda qansha ko'p detal jasag'an? 
184. Ali'w a'meli qa'siyetlerinen paydalani'p, qolayli' usi'da yesaplan':
 a) $(3\ 426 + 2\ 345) - 345$; b) $(3\ 453 + 898) - 2\ 353$;
 d) $12\ 387 - (12\ 187 - 887)$; e) $(6\ 578 + 1\ 437) - 1578$.
185. A'mellerdi wori'nlan':
 a) $12\ 478 - 12\ 378 + 7934$; b) $38\ 709 + 13\ 576 - 21\ 709$;
 d) $28\ 676 + 1111 - 21\ 776$; e) $41\ 512 + 13\ 924 - 23\ 412$.
186. Tuwri'mu'yeshlik formasi'ndag'i' mektep ha'wlisinin' uzi'nli'g'i' 216 m, yeni bolsa uzi'nli'g'i'nan 45 m qi'sqa. Mektep ha'wlisinin' perimetrin yesaplan'.
187. «Lasetti» avtomobili massasi' 1246 kg, «Kobalt» avtomobili massasi' bolsa 1149 kg (4- su'wret). «Kobalt» avtomobili «Lasetti» avtomobilinen neshe kilogrammg'a jen'il?



4- su'wret

Bilimin'izdi si'nap ko'rin'!



Bul bapti'n' materiallari'n u'yrenip shi'g'i'p, to'mendegi ma'selelerdi sheshe ali'wi'n'i'z sha'rt! Qadag'alaw jumi'si' aldi'nan wo'zin'izdi si'nap ko'rin'!

2-qadag'alaw jumi'si' u'lgisi

- A'mellerdi wori'nlan':
 a) $249\ 638 + 83\ 554$; b) $665\ 247 - 8296$.
- a) 28 763 sani'nan 9338 ge u'lken bolg'an sandi' tabi'n'.
 b) 59 345 sani' 53 568 sani'nan qansha u'lken?
 d) 59 345 sani' 69 965 sani'nan qansha kishi?
- Birinshi yashikte 62 kg alma bar boli'p, bul yekinshi yashiktegi almadan 18 kg g'a ko'p. Yekinshi yashikte qansha alma bar??
- MFK u'shmu'yeshliginin' FK ta'repi 62 sm. FK ta'repinen KM ta'repi 1 dm uzi'n, MF ta'repi bolsa 16 sm qi'sqa. U'shmu'yeshliktin' perimetrin tabi'n' ha'm woni' dm de an'lati'n'.
- Tuwri' si'zi'qli' jol boylap 15 na'l yegildi. Na'ller arasi'ndag'i' arali'q birdey. Yeger da'slepki ha'm son'g'i' na'ller arasi'ndag'i' arali'q 210 dm bolsa, qon'si'las na'ller arasi'ndag'i' arali'qti' tabi'n'.

9.1. Sanli' an'latpalar

1- su'wrette ko'rsetilgen, ta'repleri 4 sm ha'm 6 sm bolg'an tuwri' to'rtmu'yeshtin' perimetri nege ten'?

Bizge belgili, usi' to'rtmu'yeshtin' perimetri $2 \cdot 4 + 2 \cdot 6$ ko'rinisidagi an'latpa penen ani'qlanadi'.

Sanlar, arifmetikali'q a'meller ha'm qawi'slardan du'zilgen bunday *an'latpalar sanli'* an'latpalar dep ataladi'.

Ma'selen, $23 - (12 + 45)$ ha'm $12 \cdot 40 - 450 : 9$ an'latpalar sanli' an'latpalar.

Sanli' an'latpada a'meller belgilengen ta'rtipte wori'nansa, *sanli' an'latpani'n' ma'nisi* payda boladi'.

Joqari'dag'i' sanli' an'latpani'n' ma'nisi, yag'ni'y tuwri' to'rtmu'yeshtin' perimetri $2 \cdot 4 + 2 \cdot 6 = 20$ (sm) ge ten'.

Ta'repleri 4 sm ha'm a sm bolg'an tuwri' to'rtmu'yeshtin' perimetri nege ten' boladi'? Bu sorawg'a juwap – $2 \cdot 4 + 2 \cdot a$ ko'rinisidagi an'latpa boladi'.

Sanlar, arifmetikali'q a'melle, qawi'slar menen bir qatarda ha'ripler de qatnasqan an'latpa *ha'ripli ya'ki ha'ripli an'latpa* dep ataladi'.

$a \cdot 40 - a \cdot b$ ha'm $23 - (a : c + 45)$ ha'ripli an'latpalar.

A'dette, ha'ripli an'latpalarda san ha'm ha'ripli ya'ki ha'ripler wortasi'ndag'i' ko'beytiw a'meli belgisi jazi'lmaydi'. Sonday-aq, ha'ripli an'latpada ko'beytiwshiler san ha'm ha'rip bolsa, sandi' ha'ripten aldi'n yazi'wg'a kelisilgen.

Ma'selen, joqari'dag'i' $a \cdot 40 - a \cdot b$ ha'ipli an'latpada $40a - ab$ tu'rinde jazi'ladi'.

Ha'ripli an'latpadag'i' ha'rip warni'na tu'rli sanlardi' qoyi'w mu'mkin. Bul sanlar *ha'riptin' ma'nisleri* dep ataladi'. Ha'rip an'latpadag'i' ha'rip warni'na san qoyi'p yesaplang'anda shiqqan na'tiyjege *ha'rtipli an'latpani'n' ma'nisi* delinedi'.

1-mi'sal. Jumi'sshi' 2 saat isledi. Wol birinshi saatta 12 dana, yekinshi saatta bolsa wonnan 6 dana ko'p detal tayarladi'. Jumi'sshi' yeki saatta ja'mi neshe dana detal tayarlag'an.

Sheshiliwi. Aldi'n sanli' an'latpa du'zemiz. Ma'sele sha'rtine baylani'sli', jumi'sshi' yekinshi saatta $12 + m$ dana detal tayarlag'an. Demek, wol yeki saat ishinde $12 + (12 + m)$ dana detal tayarlag'an.

a) $12 + (12 + m)$ ha'ripli an'latpani'n' $m=4$ bo'lg'endegi ma'nisi: $12 + (12 + 4) = 28$;

b) $12 + (12 + m)$ ha'ripli an'latpani'n' $m = 8$ bo'lg'endegi ma'nisi: $12 + (12 + 8) = 32$;

Javob. $12 + (12 + m)$; a) 28; b) 32.

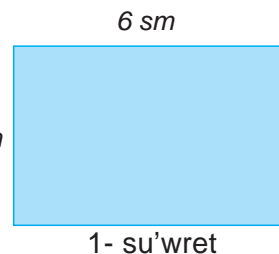

4 sm

6 sm

1- su'wret



Sorawlarg'a juwap berin'!

1. Sanli' an'latpalarg'a mi'sallar keltirin'.
2. Sanli' an'latpani'n' ma'nisi qalay tabi'ladi'?
3. Ha'ripli an'latpa dep qanday an'latpag'a ayti'ladi'?
4. Ha'ripli an'latpani'n' ma'nisi dep nege ayti'ladi'?

Klasta wori'nlanatug'i'n shi'ni'g'i'wlar



188. Sanli' an'latpani'n' ma'nisin tabi'n':
 a) $13 \cdot 5 + 98$; b) $127 + 108 : 3 - 24$; d) $12 \cdot 8 + 98 - 35$;
 e) $23 \cdot 4 + 121 : 11$; f) $5 \cdot 23 + 6 \cdot 41$; g) $455 : 5 - 13 \cdot 7 + 43$.

189. Ha'ripli an'latpani'n' ma'nisin tabi'n':
 a) $128 - b$, bunda $b = 31$; 43; 59. b) $b - 18$, bunda $b = 39$; 124; 215.
 d) $35 + x$, bunda $x = 0$; 10; 100. e) $125 - x$, bunda $x = 0$; 110; 98.

U'lgi: a) $b = 31$ bolg'anda, $128 - b = 128 - 31 = 97$.

190. Ha'ripli an'latpani'n' ma'nisin tabi'n':
 a) $(128 - 12b) + (14b - 18)$, yeger $b = 3$; 4; 5.
 b) $(30y - 25) - (20y + 10)$, yeger $y = 4$; 8; 10.

U'lgi: a) $b = 3$ bolg'anda, $(128 - 12b) + (14b - 18) =$
 $= (128 - 12 \cdot 3) + (14 \cdot 3 - 18) = (128 - 36) + (42 - 18) = 92 + 24 = 116$.



191. Azizada b dana CD disk bar yedi. Wog'an doslari' ja'ne 5 disk sawg'a yetti. Azizada ja'mi qansha disk boldi'?
192. Ajag'asi' x jasta, u'kesi wannan 8 jas kishi. U'kesi neshe jasta? Ajag'asi'ni'n' jasi' a)10; b)14; d)16 g'a ten' bolg'anda, u'kesi neshe jasta boladi'?
193. Ag'ash ustasi' u'sh ku'nde buyi'rtpani' wori'nlati'. Birinshi ku'ni wol 24, yekinshi ku'ni birinshi ku'ndegiden a ma'rte ko'p ha'm u'shinshi ku'ni bolsa yekinshi ku'ndegiden 4 ke kem stul jasaki'. $a = 8$; 10; 12 ma'nislerinde ag'ash ustasi' jasag'an barli'q stullar sani'n yesaplan'.

U'yde wori'nlanatug'i'n ma'seleler



194. Sanli' an'latpalardi'n' ma'nisin tabi'n':
 a) $81 : 9 + 12 \cdot 5$; b) $127 \cdot 2 + 145 : 5$; d) $22 \cdot 4 + 180 : 15 + 43$.

195. Ha'ripli an'latpani'n' ma'nisin tabi'n'.
 a) $28 - c$, bunda $c = 12$; 24. b) $d - 109$, bunda $d = 139$; 523.

196. Ha'ripli an'latpani'n' ma'nisin tabi'n'.
 a) $(19 - 7b) + (9b - 8)$, bunda $b = 1$; 2.
 b) $(5a - 3) + (8a + 16)$, bunda $a = 1$; 2; 3.



197. Shaxja'hende a sandag'i' kitap bar yedi. Wol dosti'si'na 3 kitapti' woqi'wg'a berdi. Shaxja'hanni'n' kitapxanasi'nda qansha kitap qaldi'?
198. Birinshi qa'lem i'di'sta 12, yekinshisinde bolsa birinshisinen m dana kem qa'lem bar. Yekinshi qa'lem i'di'sta neshe qa'lem bar? $m = 6$; 8 bolg'anda ma'seleni sheshin'.
199. Alisher u'sh ku'nde kitapti' woqi'p boldi' ha'm wol birinshi ku'ni 56 bet, yekinshi ku'ni birinshi ku'ndegiden c bet ko'p ha'm u'shinshi ku'ni bolsa yekinshi ku'ndegiden 24 bet kem woqi'di'. Kitap neshe betten ibarat? $c = 21$; 16 bolg'anda ma'seleni sheshin'.

10-§. QOSI'W HA'M ALI'WDI'N' QA'SI'YETLERININ' HA'RIPLI AN'LATPASI'

Qosi'w ha'm ali'w a'mellerinin' sizge tani's qa'siyetlerin ha'ripler ja'rdeminde to'mendegishe an'lati'w mu'mkin:

10.1. Qosi'w a'melinin' qa'siyetleri

a) qosi'wdi'n' wori'n almasti'ri'w ni'zami': $a + b = b + a,$

bul ten'llikte a ha'm b qa'legen natural san ha'm 0 ma'nisilerin qabi'l qi'li'wi' mu'mkin.

b) qosi'wdi'n' gruppalam ni'zami': $a + (b + c) = (a + b) + c,$

bul jerde a, b ha'm c qa'legen natural san ha'm 0 ma'nislerin qabi'l yetedi.

d) qosi'wda noldin' qa'siyeti: $a + 0 = 0 + a = a,$

bul jerde a – qa'legen natural san ha'm 0 ma'nisilerin qabi'l qi'li'wi' mu'mkin.

10.2. Ali'w a'melinin' qa'siyetleri

a) sannan qosi'ndi'ni' ali'w qa'siyeti: $a - (b + c) = a - b - c,$

bul jerde a, b ha'm c sanlari' $b + c < a$ yamasa $b + c = a$ sha'rtin qanaatlandi'ri'wshi' qa'legen natural sanlar.

b) qosi'ndi'dan sandi' ali'w qa'siyeti:

Eger a, b ha'm c sanlar $c < b$ yamasa $c = b$ sha'rtin qanaatlandi'ri'wshi' qa'legen natural sanlar bolsa, $(a + b) - c = a + (b - c).$

Eger a, b ha'm c sanlar $c < a$ yamasa $c = a$ sha'rtti qanaatlandi'ri'wshi' qa'legen natural sanlar bolsa, $(a + b) - c = (a - c) + b.$

d) ali'wda noldin' qa'siyeti: $a - 0 = a; \quad a - a = 0,$

bul jerde a – qa'legen natural san ha'm 0 ma'nislerin qabi'l yetiwi mu'kin.

10.3. Qa'siyetlerdin' an'latpalardi' a'piwayi'lasti'ri'wda qollani'li'wi'

Qosi'w ha'm ali'w a'mellerinin' qa'siyetlerin qollani'w – ha'ripli an'latpalardi' a'piwaylasti'ri'wg'a imkaniyat beredi. Buni' to'mendegi mi'sallarda ko'rsetemiz:

1- mi'sal. $34 + x + 23$ ha'ripli an'latpani' a'piwaylasti'ri'n'.

Sheshiliwi:

Qosi'wdi'n' wori'n almasti'ri'w ni'zami' boyi'nsha	$34 + x = x + 34$
Bunnan paydalansaq	$34 + x + 23 = x + 34 + 23 = x + (34 + 23) = x + 57.$

Juwabi': $x + 57.$

2- mi'sal. $67 - (23 + x)$ an'latpani' a'piwaylasti'ri'n'.

Sheshiliwi:

Sannan qosi'ndi'ni' ali'w qa'siyeti boyi'nsha:	$67 - (23 + x) = (67 - 23) - x = 44 - x.$
--	---

Juwabi': $44 - x.$

3- mi'sal. $y - 82 - 55$ ha'ripli an'altpani' a'piwaylasti'ri'n'.

Sheshiliwi:

Sannan qosi'ndi'ni' ali'w qa'siyeti boyi'nsha:	$y - 82 - 55 = y - (82 + 55) = y - 137.$
--	--

Juwabi': $y - 137.$

4- mi'sal. $184 - x - 14$ an'latpani' a'piwaylasti'ri'n'.

Sheshiliwi:

Sannan qosi'ndi'ni' ali'w qa'siyeti boyi'nsha:	$184 - x - 14 = 184 - (x + 14).$
Qosi'wdi'n'wori'n almasti'ri'w ni'zami' boyi'nsha:	$x + 14 = 14 + x$ $184 - (x + 14) = 184 - (14 + x).$
Sannan qosi'ndi'ni' ali'w qa'siyeti boyi'nsha:	$184 - (14 + x) = 184 - 14 - x = 170 - x.$

Juwabi': $170 - x.$

5- mi'sal. $(78 + x) - 44$ an'latpani' a'piwaylasti'ri'n'.

Sheshiliwi:

Qosi'ndi'dan sandi' ali'w qa'siyeti boyi'nsha:	$(78 + x) - 44 = (78 - 44) + x = 34 + x.$
--	---

Juwabi': $34 + x.$

6- mi'sal. $y - 62 + 91$ an'latpani' a'piwaylasti'ri'n'.

Sheshiliwi:

An'latpani' qosi'ndi' ko'rinisinde jazami'z:	$y - 62 + 91 = (y - 62) + 91 =$
Qosi'ndi'dan sandi' ali'w qa'siyeti boyi'nsha:	$= (y + 91) - 62 = y + (91 - 62) = y + 29.$

Juwabi': $y + 29.$

Sorawlarg'a juwap berin'!



- $a + (b + c) = (a + b) + c$ ten'lik qosi'wdi'n' qaysi' ni'zami'n an'latadi'?
- Qosi'wdi'n' wori'n almasti'ri'w ni'zami'n so'zler menen bayan yetin'.
- To'mendegi sannan qosi'ndi'ni' ali'w qa'siyeti duri's jazi'lg'anba?

$$a - (b + c) = a - b + c$$

- Ali'wda noldin' qa'siyetin ayti'n'.



Klasta wori'nlanatug'i'n shi'ni'g'i'wlar

200. Ha'ripli an'latpani' a'piwayi'lasti'ri'n':
 a) $76 + x + 45$; b) $19 + 89 + x$; d) $x + 123 + 453$; e) $324 + x + 745$.

U'lg'i: Joqari'da ko'rilgen 1-mi'sal.

201. Ha'ripli an'latpani' aldi'n a'piwayi'lasti'ri'p, wonnan son' ma'nisin tabi'n':
 a) $23 + m + 19$, bul jerde $m = 3$; b) $37 + 71 + y$, bul jerde $y = 12$.

202. Abdirahman du'kannan 4000 swmg'a qumsheker ha'm qumshekerden a swm ko'p pulg'a sari'may sati'p aldi' ha'm wol ja'mi neshe swm sawda qi'lg'an?

203. Ha'ripli an'latpani' a'piwayi'lasti'ri'n':
 a) $34 - (12 + x)$; b) $89 - (9 + x)$; d) $y - 671 - 90$; e) $z - 280 - 251$.

U'lg'i: Joqari'da ko'rilgen 2- ha'm 3- mi'sallar.

204. Ha'ripli an'latpani' aldi'n a'piwayi'lasti'ri'p, wonnan son' woni'n' ma'nisin tabi'n':
 a) $65 - (22 + n)$, bul jerde $n = 30$; b) $p + 15 + 69$, bul jerde $p = 12$;



205. Ha'ripli an'latpani' a'piwayi'lasti'ri'n'.
 a) $128 - x - 89$; b) $29 - x - 27$; d) $671 - y - 90$; e) $280 - z - 251$.

U'lg'i: Joqari'da ko'rilgen 4-mi'sal.

206. An'latpani' a'piwaylasti'ri'n':
 a) $(91 + x) - 48$; b) $(66 + x) - 53$; d) $y - 39 + 72$; e) $y - 27 + 83$.

U'lg'i: Joqari'da ko'rilgen 5- ha'm 6- mi'sallar.

207. Ha'ripli an'latpani' aldi'n a'piwaylasti'ri'p, wonnan son' ma'nisin tabi'n':
 a) $(651 + x) - 480$, bul jerde $x = 13$; b) $y - 93 + 21$, bul jerde $y = 125$.

208. Zafar yeki g'arbi'z sati'p aldi'. Birinshi g'arbi'zdi'n' massasi' 3 kg, yekinshisniki wonnan m kg awi'r. Yeki g'arbi'zdi'n' massalari'ni'n' qosi'ndi'si'n an'lati'wshi' ha'ripli an'latpa du'zin'. An'latpani' a'piwayi'lasti'ri'n' ha'm a) $m = 2$; b) $m = 3$ bolg'andag'i' ma'nisin tabi'n'.



U'yde wori'nlanatug'i'n ma'seleler

209. $76 + x + 45$ an'latpani' a'piwayi'lasti'ri'n'.
 210. $19 + 89 + x$ an'latpani' a'piwayi'lasti'ri'p, wonnan son' $x = 12$ bolg'andag'i' ma'nisin tabi'n'.

211. Hadiysha gu'lzarg'a kirip, birinshi ku'ni 56 tu'bektegi gu'llerge suw quydi'. Yekinshi ku'ni bolsa birinshi ku'ndegiden p dana ko'p gu'lge suw quydi'. Hadiysha ja'mi neshe gu'lge suw quyg'an? Juwapti' a'piwayi'lasti'ri'p jazi'n'.

212. Ha'ripli an'latpani' a'piwayi'lasti'ri'n':
 a) $435 - (x + 45)$; b) $y - 671 - 90$.

213. $128 - x - 89$ an'latpani' a'piwayi'lasti'ri'n'.

214. $29 - x + 27$ an'latpani' a'piwayi'lasti'ri'n', wonnan son' $x = 32$ bolg'andag'i' ma'nisin tabi'n'.

215. An'latpani' a'piwayi'lasti'ri'n': a) $(91 + x) - 48$; b) $p - 47 + 78$.

216. Qabaqlardi'n birinin' massasi' 9 kg, yekinshisinin' massasi' bolsa birinshisikiniken n kg g'a kam. Qabaqlardi'n' umi'wma massasi' qansha? Juwapti' a'piwayi'lasti'ri'n' ha'm a) $n = 3$; b) $n = 5$ bolg'andag'i' ma'ni'sin tabi'n'.

11.1. Ten'leme tu'sinigi

Ma'sele sha'rti so'zler menen an'latiladi'. I'tibar bergen bolsan'i'z, ha'r bir ma'sele sha'rtinde bazi' sha'malardi'n' ma'nisi berilgen boladi', ayi'ri'mlari' bolsa belgisiz boladi' ha'm wolar arasi'nan belgisiz bolg'an birewinin' ma'nisin tabi'w talap yetiledi.

Ma'sele matematikali'q belgiler ja'rdeminde qayta an'latil'sa, belgisiz sandi' an'sat tabi'w mu'mkin boladi'. Bir neshe ma'seleni ko'reyik:

1-mi'sal. A'lisher bir da'pter sati'p ali'p ati'ri'p, sati'wshi'g'a 500 swm berdi. Sati'wshi' wog'an 200 swm qaytardi'. Da'pter neshe swm turadi'?

Sheshiliwi. Bul ma'selede A'lisherdin' sati'wshi'g'a bergan puli' (500 swm) ha'm sati'wshi'ni'n' A'lisherge qaytarg'an qayti'mi' (200 swm) belgili, da'pterdin' bahasi' bolsa belgisiz. Kelin' belgisiz shama – da'pter bahasi'n x penen belgileyik.

Wonda $x + 200 = 500$ an'latpag'a iye bolami'z.

Bul ma'sele sha'rtinin' matematikali'q belgileri ja'rdeminde jazi'lg'an an'latpa-si' boladi'.

Bul jazi'w ten'likten ibarat boli'p, woni'n' sol ta'repindegi ha'ripli an'latpa $x + 200$, won' ta'repinde bolsa 500 sani' turi'pti'. Soni'n' menen birgelikte wonda belgisiz sha'ma x qatnasadi'i.

x ha'ribinin' woni'na ha'r qi'yli' sanlardi' qoyi'p ko'riw mu'mkin. Na'tiyjede x ti'n' ayri'm ma'nislerinde ten'lik duri's, ayri'm ma'nislerinde naduri's boladi'.

Ma'selen, $x + 200 = 500$ ten'lik $x = 300$ bolg'anda duri's, $x = 200$ bolg'anda naduri's boladi'. Biz x ti'n' sonday ma'nisin tabi'wi'mi'z kerek, woni' ten'likke qoyg'anda, duri's ten'lik payda bolsi'n. Sonda g'ana ma'sele sheshilgen boladi'.

Belgisiz ma'nisti tabi'w talap yetilip ati'rg'an ha'rip qatnasqan ten'likke **ten'leme** dep ataladi'.

Belgisiz ha'ripti'n' duri's ten'likke aylandi'ratug'i'n ma'nisi **ten'lemen'in' kozeni (sheshimi)** dep ataladi'.

Ten'lemeni sheshiw – dep, woni'n' barli'q sheshimlerin tabi'wg'a (yamasa woni'n' hesh bir sheshimi joqli'g'i'n ani'qlawg'a) ayti'ladi'.

Ma'selen, $x + 200 = 500$ ten'lemenin' sheshimi 300 boladi'.

2-mi'sal. Belgisiz sang'a 12 qosi'lg'anda 23 payda boldi. Belgisiz sandi' tabi'n'.

Sheshiliwi. Belgisiz sandi' x penen belgileymiz. Wonda ma'sele sha'rtine ko're $x + 12 = 23$ ten'likke iye bolami'z.

Ali'w a'meli ma'nisinen kelip shi'g'atug'i'n bolsaq, bul san 23 ha'm 12 sanlari'ni'n' ayi'rmasi'nan ya'ki $23 - 12 = 11$ sani'nan ibarat boladi'.

Demek, $x + 12 = 23$ ten'lemenin' sheshimi $x = 11$, yag'ni'y belgisiz san 11 ge ten'.

11.2. Belgisiz qosi'li'wshi'ni' tabi'w

3- mi'sal. $x + 23 = 57$ ten'lemeni sheshin'.

Sheshiliwi. Ma'selenin' sha'rti boyi'nsha yeki qosi'li'wshi'ni' qosi'ndi'si' 57 ge ten'. Qosi'li'wshi'lardan biri belgisiz ha'm woni' tabi'w talap yetiledi.

$$\begin{aligned} x + 23 &= 57 \\ x &= 57 - 23 \\ x &= 34 \end{aligned}$$

Ali'w a'melinin' ma'nisi boyi'nsha belgisiz qosi'li'wshi', qosi'ndi' ha'm yekinshi qosi'li'wshi' ayi'rmasi'na ten'.

Demek, $x = 57 - 23$, yag'ni'y $x = 34$.

34 sani' haqi'yqati'nda da $x + 23 = 57$ ten'lemenin' sheshimi boladi', sebebi bul sandi' x ti'n' worni'na qoysaq, ten'leme $34 + 23 = 57$ duri's ten'likke aylanadi'.

Juwabi': $x = 34$.



Belgisiz qosi'li'wshi'ni' tabi'w ushi'n qosi'ndi'dan belgili qosi'li'wshi'ni' ali'w kerek.

11.3. Belgisiz azayi'wshi'ni' tabi'w

4- mi'sal. $y - 9 = 16$ ten'lemeni sheshin'.

Sheshiliwi. Ma'selenin' sha'rti boyi'nsha yeki san ayi'rmasi' 16 g'a ten'. Azayi'wshi' bolsa belgisiz ha'm woni' tabi'w talap yetiledi.

$$\begin{aligned} y - 9 &= 16 \\ y &= 16 + 9 \\ y &= 25 \end{aligned}$$

Ali'w a'melinin' ma'nisi woyi'nsha, y ti'n' ma'nisi 16 ha'm 9 sanlari'ni'n qosi'ndi'si'na ten'.

Demek, $y = 16 + 9$, yag'ni'y $y = 25$.

25 sani' haqi'yqati'nda da $y - 9 = 16$ ten'lemenin' sheshimi, sebebi $25 - 9 = 16$ duri's ten'lik

Juwabi': $y = 25$.



Belgisiz azayi'wshi'ni' tabi'w ushi'n ali'ni'wshi'ni' ayi'rmag'a qosi'w kerek.

11.4. Belgisiz ali'ni'wshi'ni' tabi'w

5-mi'sal. $38 - z = 12$ ten'lemeni sheshin'.

Sheshiliwi. Ma'selenin' sha'rti boyi'nsha yeki sani'n' ayi'rmasi' 12 ge ten'. Biraq, bul sapari' ali'ni'wshi' belgisiz ha'm woni' tabi'w talap yetiledi.

$$\begin{aligned} 38 - z &= 12 \\ z &= 38 - 12 \\ z &= 26 \end{aligned}$$

Ali'w a'melinin' ma'nisi boyi'nsha, 38 sani' z ha'm 12 sanalari'ni'n qosi'ndi'si'nan ibarat:

$$z + 12 = 38.$$

Bul ten'lemeden belgisiz qosi'li'wshi'ni' tabami'z: $z = 38 - 12$, yag'ni'y $z = 26$. 26 sani' $38 - z = 12$ ten'lemenin' sheshimi, sebebi $38 - 26 = 12$ duri's ten'lik.

Juwabi': $z = 26$.



Belgisiz ali'ni'wshi'ni' tabi'w ushi'n azayi'wshi'dan ayi'rmani' ali'w kerek.

6-mi'sal. $(x + 43) - 23 = 52$ ten'lemeni sheshin'.

Sheshiliwi. Bul ten'lemeni yeki tu'rli usi'lda sheshiw mu'mkin.

1-usul. Ten'lemenin' shep ta'repin $(x + 43)$ ha'm 23 sanlari'ni'n' ayi'rmasi' si'pati'nda ali'p, aldi'n belgisiz azayi'wshi' $(x + 43)$ ni' tabami'z:

$$(x + 43) = 52 + 23, \quad x + 43 = 75.$$

Son' aqi'rg'i' ten'lemedegi belgisiz qosi'li'wshi'ni' tabami'z:

$$x = 75 - 43 = 32.$$

Juwabi': $x = 32$.

$$(x + 43) - 23 = 52$$

$$x + 43 = 52 + 23$$

$$x + 43 = 75$$

$$x = 75 - 43$$

$$x = 32$$

2-usi'l. Aldi'n ten'lemenin' sol ta'repinde $(x + 43) - 23$ an'latpani' ali'w a'meli qa'siyetinen paydalani'p a'piwayi'lasti'rami'z:

$$(x + 43) - 23 = x + 43 - 23 = x + 20.$$

Son' woni' ten'lemege qoyami'z:

$$x + 20 = 52.$$

Bul ten'lemeden belgisiz qosi'li'wshi'ni' tabami'z:

$$x = 52 - 20,$$

Juwabi': $x = 32$.

Ko'rip turg'ani'n'i'zday, ha'r yeki jag'dayda da ten'leme sheshimi bir qi'yili shi'qti'. Bul – ten'leme sheshiminin'duri's tabi'lg'ani'n bildiredi.

$$(x + 43) - 23 = 52$$

$$x + 43 - 23 = 52$$

$$x + (43 - 23) = 52$$

$$x + 20 = 52$$

$$x = 52 - 20$$

$$x = 32$$

Sorawlarg'a juwap berin'!



1. Ten'lemenin' sheshimi degen ne?
2. Ten'lemenin' sheshimi duri's tabi'lg'anli'g'i' qalay tekseriledi'?
3. Belgisiz qosi'li'wshi' qalay tabi'ladi'?
4. Belgisiz azayi'wshi' qalay tabi'ladi'?
5. Belgisiz ali'ni'wshi'ni' tabi'w ushi'n ne qi'li'w yerek?

Klasta wori'nlanatug'i'n shi'ni'g'i'wlar



217. Ten'lemede ne belgili ha'm ne belgisizligin ani'qlan' ha'm woni' sheshin'.

U'lg'i: Joqari'da ko'rilgen 3-, 4- ha'm 5-mi'sallar.

a) $x + 45 = 79$;

e) $y - 3072 = 1136$;

b) $1306 + x = 2176$;

f) $796 - z = 423$;

d) $y - 463 = 361$;

g) $2609 - z = 1423$.

218. 3260 ha'm 4521 sanlari'ni'n' qosi'ndi'si' 7781 ge ten' yekenliginen paydalani'p, yesap-sanaqsi'z to'mendegi sanli' an'latpalardi'n' ma'nisin ha'm ten'lemelerdin' sheshimin ayti'n':

a) $7781 - 3260$;

e) $x - 3260 = 4521$;

b) $7781 - 4521$;

f) $y - 4521 = 3260$;

d) $4521 + 3260$;

g) $z + 3260 = 7781$.

219. Su'wretke qarap ten'leme du'zin' ha'm woni' sheshin'.

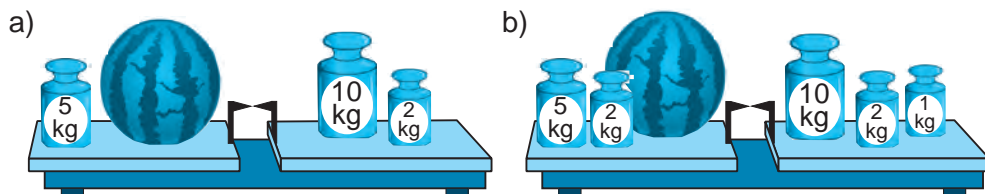

220. 23, 45, 12 sanlari'ni'n' qaysi' biri $x + 45 = 57$ ten'lemenin' sheshimi boladi'?



221. Asi'lbek ji'ynag'ani'na 26 marka qosqannan son' woni'n' markalari'ni'n' sani' 142 ge jetti. Asi'lbekte da'slep neshe marka bolg'an?

222. Skladqa 34 t ju'k keltirilgennen keyin skladta ja'mi ju'k 143 tonnag'a jetti. Skladta da'slep qansha ju'k bolg'an?

223. Su'wretke qarap ten'leme du'zin' ha'm woni' sheshin':

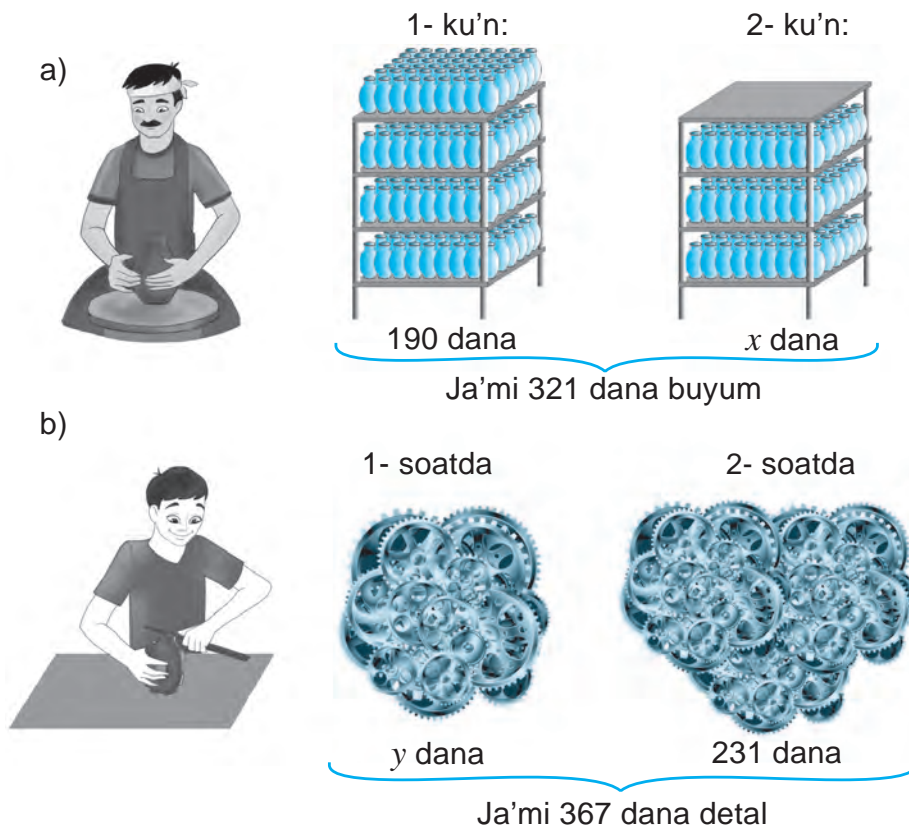

224. Quti'g'a 345 dana shokolad sali'ng'annan keyin wondag'i' ja'mi shokoladlar sani' 423 danag'a jetti. Da'slep quti'da neshe shokolad bolg'an?

225. Skladqa 89 yashik ju'zim keltirilgennen keyin, ju'zim sali'ng'an yashiklar sani' 174 ke jetti. Da'slep skladta qansha ju'zim bolg'an?

226. Bati'r bir san woyladi'. Yeger wog'an 74 ti qosi'p, payda bolg'an qosi'ndi'g'a 21 qosi'lsa 142 payda boladi'. Bati'r qaysi' sandi' woylag'an?



227. Ten'lemeni yeki usi'lda sheship, woni'n' duri's sheshilgenligin tekserin':

a) $(x + 24) - 12 = 79$;

b) $(y - 29) + 45 = 76$;

d) $(122 + x) - 291 = 157$;

e) $784 + (y - 165) = 869$;

f) $(x + 3013) + 2222 = 7162$;

g) $542 - (y - 307) = 148$.

U'lg'i: Joqari'da ko'rilgen 6-mi'sal.

228. Su'wretke qarap ten'leme du'zin' ha'm woni' sheshin'.

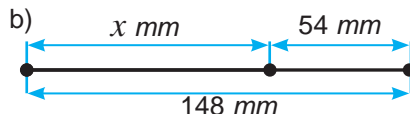
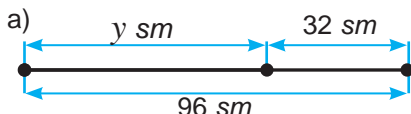

229. Ilxa'mda x dana, Bati'rda wannan 8 dana ko'p, Dilshadta bolsa Ilxa'mnan 3 dana kem da'pter bar. Ja'mi wolarda 64 da'pter bar bolsa, Ilha'mda qansha da'pter bar.

230. U'sh i'di'sta ja'mi 143 litr su't bar. Birinshi i'di'sta y litr, yekinshi i'di'sta birinshisine qarag'anda 12 litr kem, u'shinshi i'di'sta bolsa 24 litr ko'p su't bar. Birinshi i'di'sta qansha su't bar?

231. U'sh kesindinin' uzi'nli'qlari'ni'n' qosi'ndi'si' 143 dm. Birinshi kesindi uzi'nli'g'i' x dm boli'p, wol yekinshi kesindiden 23 dm qi'ssqa, u'shinshi kesindiden bolsa 21 dm uzi'n. Birinshi kesindinin' uzi'nli'g'i'n' tabi'n'.

U'yde wori'nlanatug'i'n ma'seleler



232. Ten'lemeni sheshin':

a) $x + 72 = 89$;

b) $x + 4205 = 6365$;

d) $y - 62 = 29$;

e) $y - 614 = 3112$;

f) $74 - z = 13$;

g) $1556 - z = 221$.

233. 16, 54, 22 sanlari'ni'n' qaysi' biri $x + 69 = 91$ ten'lemenin' sheshimi boladi'?

234. 55613 ha'm 2123 sanlari'ni'n' ayi'rmasi' 3490 g'a ten' yekenliginen paydalani'p, yesap-sanaqsi'z to'mendegi sanli' an'latpalardi'n' ma'nisin ha'm ten'lememlerdin' sheshimin ayti'n':

a) $5613 - 2123$;

b) $5613 - 3490$;

d) $2123 + 3490$;

e) $x - 2123 = 3490$;

f) $y - 2123 = 3490$;

g) $z + 2123 = 5613$.



235. Quti'g'a 647 dana shi'rpi' quyi'lg'annan son' wondag'i' ja'mi shi'rpi'lar sani' 1121 danag'a jetti. Da'slep quti'da neshe shi'rpi' bolg'an?

236. Boshkag'a 214 litr suw sali'ng'annan son', wondag'i' suw mug'dari' 391 litrge jetti. Das'lep i'di'sta qansha suw bolg'an?

237. Katushkada ja'mi 2495 m si'm bar yedi. Wonnan 897 m si'm kesip ali'ndi'. Katushkada qansha si'm qaldi'?

238. Su'wret boyi'nsha ten'leme du'zin' ha'm sheshin':

a)

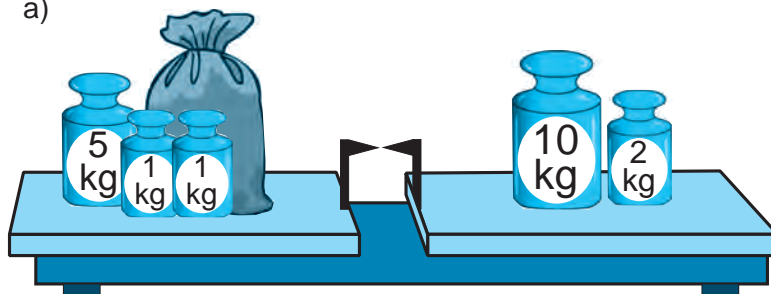

b) Bar yedi:

Sati'ldi':

Qaldi':



423 dana



165 dana



x dana

239. Xamid bir san woyladi'. Yeger wog'an 45 ti qosi'p, payda bolg'an qosi'ndi'g'a ja'ne 32 qosi'lsa, 84 payda boladi'. Xamid qaysi' sandi' woylag'an?

240. Ten'lemeni sheshin' ha'm sheshimdi tekserin':

a) $(x + 33) - 39 = 82$;

b) $(y - 37) + 21 = 69$;

d) $(12 + x) - 129 = 409$;

e) $(x + 6275) + 1231 = 9177$.

241. Azizada x dana, Nargizada wonnan 8 dana ko'p, Dilnazada bolsa Azizadan 3 dana kem kitap bar. Ja'mi apa-sin'lilerde 64 kitap bar bolsa, Azizada neshe kitap bar?

242. U'sh kesindinin' uzi'nli'qlari'ni'n' qosi'ndi'si' 243 sm. Birinshi kesindinin' uzi'nli'g'i' y sm boli'p, wol yekinshi kesindiden 13 sm uzi'n, u'shinshi kesindiden bolsa 65 sm qi'ssqa. Birinshi kesindinin' uzi'nli'g'i'n tabi'n'.

243. Su'wret boyi'nsha ten'leme du'zin' ha'm woni' sheshin'.

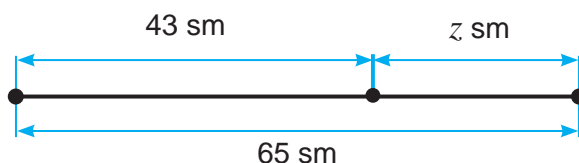

12-§.

II BAPTI' TA'KIRARLAWG'A TIYISLI MA'SELELER SHESHIW

12.1. Ma'sele sheshiw din' ten'lestiriw usi'li'

1- mi'sal Yeki baylamda ja'mi 70 da'pter bar. Yekinshi baylamda birinshisine qarag'anda 10 da'pter ko'p. Ha'r bir baylamda neshe da'pter bar?

Sheshiliwi. Woyi'mi'zda baylamdag'i' da'pterler sani'n ten'lestiremiz (1-su'wret). Buni'n' ushi'n yekinshi baylamnan 10 da'pterdi alami'z. Wonda yeki baylamda ja'mi $70 - 10 = 60$ da'pter qaladi'.

Yendi ha'r baylamdag'i' da'pterler sani' ten'lesti ha'm $60 : 2 = 30$ da'pterge ten'.

Usi'lay yetip, birinshi baylamda 30 da'pter bar yekenligin ani'qladi'q. Wonda, sha'rt boyi'nsha yekinshi baylamda birinshisinen 10 g'a ko'p $30 + 10 = 40$ da'pter boladi'.

Juwabi': Birinchi baylamda 30 ta, yekinshisinde 40 tan da'pter bar.

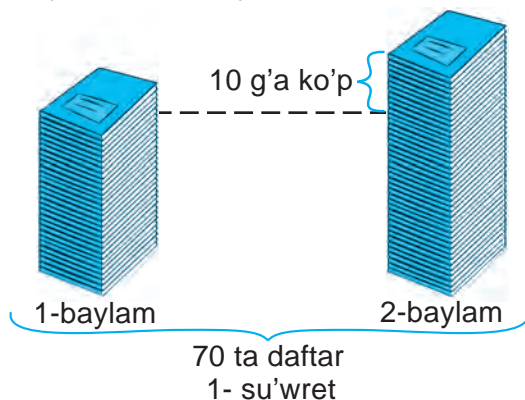

2- mi'sal. U'sh tekshede 47 kitap bar. Yekinshi tekshede birinshisinen 4 ke kem, u'shinshisinen 2 ge ko'p kitap bar. Birinshi tekshede neshe kitap bar?

Sheshiliwi. Ma'selenin' sha'rti boyi'nsha sxemali' su'wret si'zami'z (2-su'wret). U'shinshi tekshege 6, yekinshi tekshege bolsa 4 kitapti qoydi'q dep woypap, tekshedegi kitaplar sani'n ten'lestiremiz. Wonda, u'sh tekshedegi ja'mi kitaplardi'n' sani': $47 + 10 = 57$ (ta) ga teng bo'ladi.

Demek, birinshi tekshedegi kitaplar sani': $57 : 3 = 19$ boladi.

Juwabi': Birinshi tekshede 19 kitap bar.

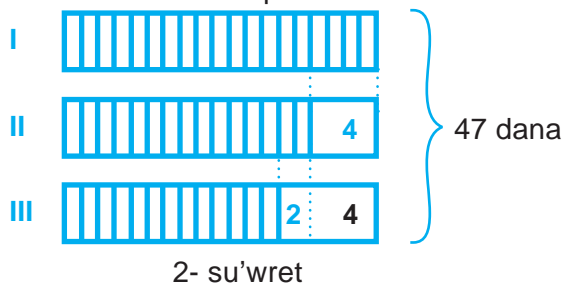

3- mi'sal. Yeki tekshede 12 kitap bar. Birinshi teksheden yekinshi tekshege, yekinshi tekshede neshe kitap bolsa, sonsha kitap ali'p qoyi'lsa, tekshedegi kitaplar sani' ten'lesedi. Da'slep tekshelerdin' ha'r birinde neshe kitaptan bolg'an? (Bul ma'seleni wo'z betinshe sheshin').

12.2. Woylaw usi'li' menen sheshiletug'i'n ma'seleler

4- mi'sal. A'yyemgi Qi'tay ma'selesi. Tor setkada tustawi'q ha'm qoyanlar bag'i'lmaqta. Wolardi'n' ja'mi baslari'ni'n' sani' 35, ja'mi ayaqlari' bolsa 94. Tor setkada neshe tus tawi'q ha'm qoyan bar?

Sheshiliwi. Tor setkani'n' joqari'si'na geshir qoyi'ldi' dep woylayi'q. Barli'q qoyanlar geshirdi jew ushi'n aldi'ng'i' ayaqlari'n ko'terip, artqi' ayaqlari'nda turi'p aladi'. Bul jag'dayda, tor setkadag'i' haywanlardi'n' neshe ayaqlari' jerde boladi'?

$35 \cdot 2 = 70$ ayaq jerde bolatug'i'ni' belgili. Biraq, sha'rt boyi'nsha, ja'mi ayaqlardi'n' sani' 94 ke ten'. Qalg'an ayaqlar qayaqta qaldi'? Yesapqa ali'nbag'an ayaqlar – bul qoyanlardi'n' jerden ko'terilip turg'an aldi'ng'i' ayaqlari' ha'm wolar neshew?

$$94 - 70 = 24 \text{ (dana)}$$

Wonda, bul 24 aldi'ng'i' ayaqlar neshe qoyang'a tiyisli?

$$24 : 2 = 12 \text{ (dana) qoyang'a tiyisli.}$$

Demek, qoyanlar sani' 12 yeken. Wonda, tustawi'qlar sani' $35 - 12 = 23$ boladi'.

Juwabi': Tor setkada 23 tustawi'q ha'm 12 qoyan bar.

5-mi'sal. Bir neshe balalarg'a da'pterlerdi bo'lip beriw kerek. Yeger ha'r bir balag'a 10 da'pterdan berilse 6 da'pter awi'si'p qaladi'. Yeger 11 danadan berilse 5 da'pter jetpey qaladi'. Balalar sani' neshew?

Sheshiliwi. Ha'r bir balag'a 10 da'pter beremiz. Sonda 6 dapter awi'si'p qaladi'. Awi'si'p qalg'an da'pterdan de birewden balalarg'a beremiz. Na'tiyjede, 6 balada 11 den, qalg'an balalarda bolsa 10 danadan dapter boladi'. Biraq, sha'rt boyi'nsha balalarg'a 11 danadan dapter berilgende 5 da'pter jetpey qalatug'i'n yedi.

Demek, qalg'an balalar sani' 5ew yeken. Wonda, barli'q balalar sani' $6 + 5 = 11$ yeken.

Juwabi'. Ja'mi 11bala bar.

6-mi'sal. Qori'qxonada ja'mi 24 tu'ye bar. Wolardi'n' bazi'lari' 1 wo'rkeshli, qalg'anlari' bolsa 2 wo'rkeshli. Yeger barli'q tu'yeler wo'rkeshlerinin' sani' 41 bolsa, 1 wo'rkeshli tu'yeler sani'n ani'qlan'.

7- mi'sal. Klasta 30 woqi'wshi' bar. Yeger klastag'i' qi'zlar 3 kg nan, ul balalar 5 kg nan makulatura (qag'az shi'g'i'ndi'lari') ji'ynasa, ja'mi klass boyi'nsha 122 kg makulatura ji'ynaladi'. Klasta neshe ul bala ha'm neshe qi'z bala woqi'ydi'?

12.3. II bapqa tiyisli ma'seleler sheshiw

244. Esaplan':

a) $1890 + 57\,743$;

b) $56\,467 + 32\,148$;

d) $27\,560 + 1760$;

e) $8534 + 34\,127$;

f) $50\,340 + 2602$;

g) $39\,253 + 6706$;

h) $63\,705 + 81\,453$;

i) $5296 + 42\,831$;

j) $35\,002 + 2326$.

245. Ati'zdan birinshi ku'ni 126 kg, yekinshi ku'ni birinshi ku'ndegiden 36 kg kem qulpi'nay terip ali'ndi'. U'shinshi ku'ni bolsa yekinshi ku'ndegiden 53 kg ko'p qulpi'nay terip ali'ndi'. U'sh ku'nde ja'mi neshe tonna qulpi'nay terip ali'ndi'?
246. Qosi'ndi'ni' qolayli' usi'lda yesaplan':

a) $237 + 484 + 763$; b) $2321 + 445 + 555$; d) $1234 + 456 + 1166$;
 e) $448 + 323 + 52 + 77$; f) $342 + 347 + 158 + 653$; g) $511 + 777 + 223 + 89$;

247. Su'wret boyi'nsha ten'leme du'zin' ha'm woni' sheshin'.

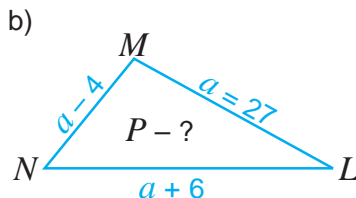
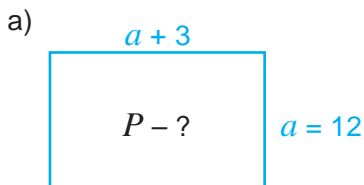

248. Ali'wdi' wori'nlan' ha'm na'tiyjeni qosi'w a'meli menen tekserin':

a) $3\ 387 - 673$; b) $5\ 812 - 1\ 919$; d) $87\ 174 - 65\ 822$;

249. Sanlar nuri'nda belgilengen noqatlardi'n' koordinatalari'n tabi'n'. MN , NL , MK , KN , NO , KM , KL , LM , ML , NL kesindilerdin' uzi'nli'g'i'n tabi'n'.



250. 3- su'wrettegi belgisiz tas massasi'n tabi'n'.

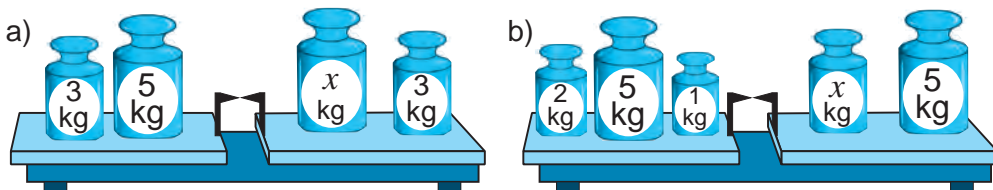

3- su'wret

251. PQ kesindide S noqati' ali'ng'an. Yeger $PQ = 43$ sm ha'm $PS = 32$ sm yekenligi belgili bolsa, SQ kesindisinin' uzi'nli'g'i'n tabi'n'.

252. Du'kanda birinshi ku'ni 1745 dana, yekinshi ku'ni bolsa 2242 dana tovar sati'ldi'. Yekinshi ku'ni birinshi ku'нге qarag'anda qansha ko'p tovar sati'lg'an?

253. Ali'w a'melinin' qa'siyetlerinen paydalani'p, qolayli' usi'lda yesaplan':

a) $(3\ 264 + 2\ 453) - 453$; b) $6\ 387 - (6\ 187 - 878)$;
 d) $(3\ 534 + 988) - 2\ 534$; e) $(26\ 785 + 1\ 437) - 11\ 785$

254. A'mellerdi wori'nlan':

a) $2478 - 2378 + 7934$; b) $8776 + 1111 - 1776$;
 d) $8709 + 3576 - 1709$; e) $4512 - 3924 + 3412$.

255. Tuwrmu'yeshlik formasi'ndagi' bo'lmenin' poli'ni'n' uzi'nli'g'i' 516 sm, yeni bolsa uzi'nli'g'i'nan 145 sm qi'sqa. Bo'lmenin' poli'ni'n' perimetrin yesaplan'.

256. An'latpani'n' ma'nisin tabi'n'.

a) $118 - y$, bunda $y = 112; 94$; b) $z - 910$, bunda $z = 1439; 5123$.

257. An'latpani'n' ma'nisin tabi'n'.

a) $(39 - 6b) + (19b - 18)$, bunda $b = 1; 2$.

b) $(15a - 13) + (18a + 16)$, bunda $a = 1; 2; 3$.

258. Birinshi qa'lem i'di'sta 24, yekinshisinde bolsa birinshisinen a dana ko'p qa'lem bar. Yeki qa'lem i'di'sta neshe qa'lem bar? $a = 4; 18$ bolg'anda ma'seleni sheshin'.

259. A'bdirahman i'ssi'xanada birinshi ku'ni 156 tu'p pomidor na'lin yekti. Yekinshi ku'ni bolsa birinshi ku'nnen p dana kem na'l yekti. A'bdirahman ja'mi neshe pomidor na'l yekken? Juwapti' a'piwaylasti'ri'p jazi'n' ha'm woni'n' $p = 34$ bolg'andagi' ma'nisin tabi'n'.

260. An'latpani' a'piwayi'lasti'ri'n': a) $2431 - (x + 247)$; b) $y - 1671 - 890$;
d) $(291 + x) - 116$; e) $y - 234 + 387$.

261. Qawi'nlar'di'n' birinin' massasi' 8 kg, yekinshisinin' massasi' bolsa birinshinikinen m kg g'a ko'p. Qawi'nlar'di'n' uli'wma massasi' qansha? Juwapti' a'piwayi'lasti'ri'n' ha'm a) $m = 2$; b) $m = 4$ bolg'andagi' ma'nisin tabi'n'.

262. 4- su'wretke qarap ma'sele du'zin' ha'm woni' sheshin'.

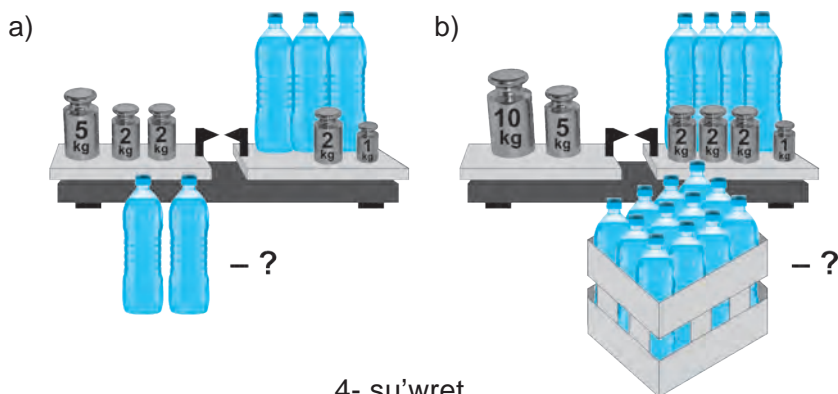

263. Ten'lemeni sheshin':

a) $x + 231 = 389$;

b) $y - 165 = 292$;

d) $275 - z = 173$;

e) $555 - z = 222$.

264. Ma'seleni ten'leme du'zip sheshin':

a) Katushkada ja'mi 329 m si'm bar yedi. Wonnan 129 m si'm kesip ali'ndi'. Katushkada qansha si'm qaldi'?

b) Qi'rmanda 4570 kg paxta bar yedi. Wog'an ja'ne 1567 kg paxta a'kelindi. Qi'rmang'a ja'mi qansha paxta wo'nimi ali'p kelingeng?

d) Munira bir san woyladi'. Yeger wog'an 61 di qosi'p, payda bolg'an qosi'ndi'dan 112 ali'nsa, 424 payda boladi'. Munira qaysi' sandi' woylag'an?

265. Ten'lemeni sheshin' ha'm sheshimin tekserin':

a) $(x + 13) - 19 = 32$;

b) $(y - 137) + 123 = 169$;

d) $(12 + x) - 12 = 40$;

e) $841 + (y - 108) = 909$.

Matematika tarixiga oid lavhalar



Al-Xorezmiydin' «Hisob al-hind» miyneti

Ulli' babami'z Al-Xorezmiy wo'zinin' «Hisob al-hind» miynetinde natural sanlardi'n' wonli'q sanaq sistemasin'nda jazi'li'wi' ha'm wolar u'stinde qosi'w, ali'w, ko'beytiw, bo'liw a'mellerin wori'nlaw qag'i'ydalari'n toli'q bayan yetken. Bul miynet XII a'sir baslari'nda lati'n tiline awdari'lg'an ha'm wonnan Yevropa universitetlerinde uzaq ji'llar dawami'nda tiykarg'i' sabaqli'q si'pati'nda paydalani'lg'an. Solay yetip, Yevropag'a wonli'q sanaq sistemasin' kirip kelgen. Yevropada Al-Xorezmiy ati' «Algarizmi», «Algaritmi», «Algaritmus» tu'rinde qollani'lg'an. Tiykari'nan, ha'zirde tilimizge teren' sin'ip ketken «algaritm» so'zi de al-Xorezmiydin' ati'nan ali'ng'an. Algaritm atamasin'in' ma'nisi-qandayda bir isti wori'nlawdin' belgili bir izbe-izligin yamasa qag'i'ydasin'an'latadi'.



Bilimin'izdi si'nap ko'rin'!



Bul baptin' materiallari'n u'yrenip shi'g'i'p, to'mendegi ma'selerdi sheshe ali'wi'n'i'z sha'rt! Qadag'alaw jumi'si' aldin'nan wo'zin'izdi si'nap ko'rin'!

Test. Duri's juwapti' ani'qlan'.

- Ma'nisi belgisiz ha'rip qatnasqan ten'lik ne dep ataladi'?
A. Sanli' an'latpa; B. Ha'ripli an'latpa; D. Sheshim; E. Ten'leme.
- 12 sani' qaysi' ten'lemenin' sheshimi?
A. $x + 3 = 12$; B. $x + 13 = 25$; D. $x + 6 = 12$; E. $x - 3 = 12$.
- Ali'ni'wshi'g'a ayi'rma qosi'lsa ne payda boladi'?
A. Qosi'ndi'; B. Ayi'rma; D. Qosi'li'wshi'; E. Azayi'wshi'.

3-qadag'alaw jumi's u'lgisi

- Ten'lemeni sheshin': a) $21 + x = 56$; b) $y - 89 = 90$.
- An'latpanin' ma'nisin tabi'n':
a) $260 + b - 160$, bunda $b = 93$; b) $a + c$, bunda $a = 20, c = 70$.
- Qolayli' usi'l menen yesaplan': a) $6485 + 1977 + 1515$; b) $863 - (163 + 387)$.
- Ten'leme du'zip sheshin':
Avtobusta 78 jolawshi' bar yedi. Avtobustan ba'ndirgide bir neshe jolawshi' tu'sti ha'm na'tiyjede avtobusta 9 jolawshi' qaldi'. Avtobustan qansha jolawshi' tu'sken?
- Uzi'nli'g'i' 20 sm bolg'an MN kesindide K ha'm F noqatlar belgilendi. Yeger $MK = 15$ sm, $FN = 13$ sm bolsa, FK kesindisinin' uzi'nli'g'in tabi'n'.

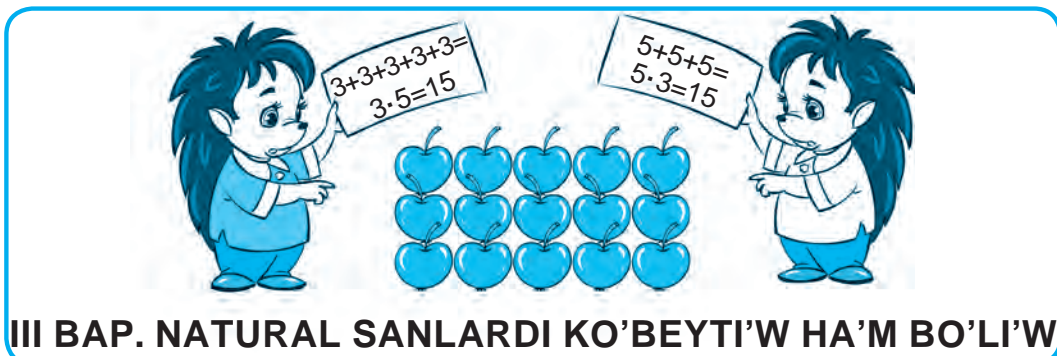

13-§. NATURAL SANLARDI KO'BEYTI'W HA' HA'M WONIN' QA'SI'YETLERI

Bag'da ha'r biri 8 tu'pten 4 qatar alma na'li yegildi. (1- su'wret). Wonda bag'da ja'mi $8 + 8 + 8 + 8$ yag'ni'y 32 tu'p alma na'li yegilgen boladi'. Demek, $8 \cdot 4 = 32$ yeken.

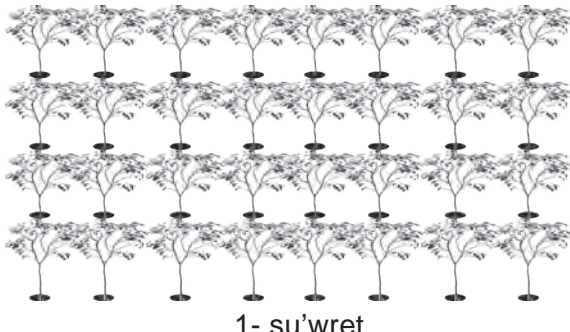

1- su'wret

! *a* sani'n *b* sani'na ko'beytiw degende, ha'r biri *a* sani'na ten' bolg'an *b* dana qosi'li'wshi'lardi'n' qosi'ndi'si'n tabi'w tu'siniledi.

$$a \cdot b = \underbrace{a + a + a + \dots + a}_{b \text{ dana qosi'li'wshi'}}$$

a ha'm *b* sanlari'ni'n' ko'beymesi $a \cdot b$. tu'rinde jazi'ladi'. Bul jerde $a \cdot b$ – ko'beyme, *a* ha'm *b* sanlari' bolsa ko'beytiwshler dep a taladi'.

$$\begin{array}{c} 8 \quad \cdot \quad 4 \quad = \quad 32 \\ \uparrow \quad \quad \uparrow \quad \quad \uparrow \\ \boxed{1\text{-ko'beytiwshi}} \quad \boxed{2\text{-ko'beytiwshi}} \quad \boxed{\text{ko'beyme}} \\ \text{5 bag'ana} \end{array}$$

Yesletip wo'temiz, 8 sani'n 4 ke ko'beytiw – woni' 4 yese artti'ri'w degeni.

1-mi'sal. Quti'g'a miywe sherbeti 4 qatar ha'm 5 bag'ana yetip jaylasti'ri'lg'an (2-su'wret). Quti'da neshe miywe sherbeti bar? Quti'dag'i' sherbetler sani'n yeki usi'lda yesaplaw mu'mkin:

Sheshiliwi. 1-usi'l. Ha'r bir qatardag'i' sherbetler sani'n qatarlar sani'na o'beytemiz:
 $5 \cdot 4 = 20$.

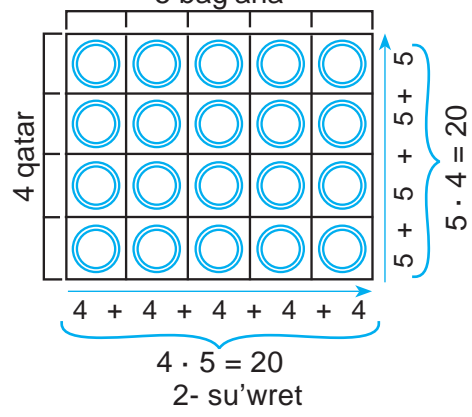

2-usi'l. Ha'r bir bag'anadag'i sherbetler sani'n bag'analar sani'na ko'beytemiz: $4 \cdot 5 = 20$. Ha'r yeki jag'dayda da bir qi'yli' na'tiyjege iye bolami'z.

Demek, $5 \cdot 4 = 4 \cdot 5$.

Ko'beytiwshilerdin' worni'n wo'zgerken menen ko'beyme wo'zgermeydi.



Bul *ko'beytiwdin' worni'n almasti'ri'w qa'siyeti* dep ataladi' ha'm wol ha'ripler ja'rdeminde to'mendegi tu'rinde jazi'ladi':

$$a \cdot b = b \cdot a$$

2-mi'sal. 3-su'wrette su'wretlengen quti'g'a 2 tu'rli sherbet jaylasti'ri'ldi'. Quti'dag'i sherbetler sani'n tabi'n'.

2-su'wrette quti'dag'i sherbetler sani'n yeki tu'rli usi'lda yesaplaw ko'rsetilgen. Ha'r yeki jag'dayda da bir qi'yli' na'tiyjege iye bolami'z. Demek, $4 \cdot (3 \cdot 2) = (4 \cdot 3) \cdot 2$.

Sandi' ko'beymege ko'beytiwde sandi' aldi'n birinshi ko'beytiwshige ko'beytiw, son' bolsa payda bolg'an ko'beymeni yekinshi ko'beytiwshige ko'beytiw jetkilikli.



Bul ko'beytiwdin' gruppalar qa'siyeti dep ataladi' ha'm ha'ripler ja'rdeminde:

$$a \cdot (b \cdot c) = (a \cdot b) \cdot c$$

tu'rinde jazi'ladi'.

Yesletip wo'temiz, sandi' 0 ha'm 1 ge ko'beytiwdin' to'mendegi qa'siyetleri bar.

Qa'legen m natural san ushi'n: $1 \cdot m = m \cdot 1 = m$, $0 \cdot m = m \cdot 0 = 0$.

San ha'm ha'riptin' ko'beymesi ko'beytiw belgisisiz jazi'ladi':

$$8 \cdot a \text{ worni'na } 8a \text{ jazi'ladi'}$$

Sog'an uqsas, qawsir'malar aldi'ndag'i ko'beytiw belgisi de a'dette jazi'lmaydi': $2 \cdot (a + b)$ worni'na $2(a + b)$ ha'm $(x + 6) \cdot (y + 3)$ worni'na $(x + 6)(y + 3)$ jazi'ladi'. Yeger ko'beymede qawsir'malar bolmasa, ko'beytiw shepten won'g'a qarap izbe-iz wori'nlanadi'.

Sorawlarg'a juwaw berin'!



1. Yeki sannin' ko'beymesi dep nege ayti'ladi'?
2. Ko'beytiletug'i'n sanlar ne dep ataladi'?
3. Ko'beytiw na'tiyjesi ne dep ataladi'?
4. Ko'beytiwdin' wori'n almasti'ri'w qa'siyetin tu'sindirin'.



Klasta wori'nlanatug'i'n shi'ni'g'i'wlar

- 266.** Ko'beyme tu'rinde jazi'n'.
 a) $18 + 18 + 18 + 18 + 18$; b) $158 + 158 + 158$; d) $a + a + a + a + a + a + a$.
- 267.** Qosi'ndi'ni' aldi'n ko'beymege keltirip, son' yesaplan':
 a) $63 + 63 + 63 + 63 + 63$; b) $425 + 425 + 425 + 425$; d) $1202 + 1202 + 1202$.
- 268.** Bir qi'yli' qosi'li'wshi'lardi' gruppalap yesaplan':
 a) $8 + 3 + 8 + 8 + 8 + 3 + 3 + 8$; b) $5 + 4 + 4 + 3 + 2 + 2 + 4 + 5 + 5 + 3 + 3 + 3$;
- 269.** Yesaplan':
 a) $14 \cdot 6$; b) $22 \cdot 1$; d) $14 \cdot 7$; e) $15 \cdot 0$;
 f) $20 \cdot 5$; g) $25 \cdot 4$; h) $8 \cdot 125$; j) $0 \cdot 2125$.
- 270.** a) 56; 854; 200 sanlari'n 36 ma'rte (yese) artti'ri'n';
 b) 306; 2301; 3904 sanlari'n 28 ma'rte (yese) artti'ri'n'.
- 271.** Ko'beymeni yesaplan':
 a) $15 \cdot 9$; b) $37 \cdot 59$; d) $63 \cdot 24$; e) $71 \cdot 86$;
 f) $712 \cdot 14$; g) $607 \cdot 35$; h) $872 \cdot 314$; i) $4\ 609 \cdot 706$;
 j) $2\ 155 \cdot 3\ 328$; k) $2\ 004 \cdot 6\ 005$; l) $37 \cdot 100$; m) $45\ 000 \cdot 83\ 000$.
- 272.** Ko'beytiw a'melinen paydalani'p an'latpani' a'piwayi'lasti'ri'n' ha'm ma'nisin tabi'n':
 a) $231 + 231 + 231 + 231 + 35$; d) $435 + 435 + 435 + 623 + 435 + 623$;
 b) $781 + 781 + 781 + 191 + 191 + 191$; e) $923 + 35 + 35 + 35 + 35 + 35 + 35$.



273. Quti'da neshe miywe sherbeti bar?

a)

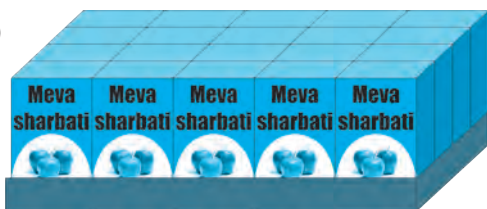

b)

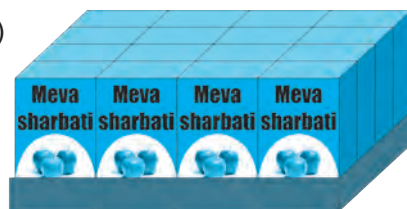

- 274.** Ko'beytiwdin' gruppalam qa'siyetinen paydalani'p ko'beymeni yesaplan':
 a) $25 \cdot (4 \cdot 815)$; b) $(111 \cdot 25) \cdot 40$; d) $8 \cdot (125 \cdot 25)$; e) $(122 \cdot 8) \cdot 25$.
U'ligi: a) $25 \cdot (4 \cdot 815) = (24 \cdot 4) \cdot 815 = 100 \cdot 215 = 81\ 500$.
- 275.** Qolayli' usi'l menen yesaplan'.
 a) $5 \cdot 342 \cdot 2$; b) $546 \cdot 5 \cdot 4$; d) $4 \cdot 987 \cdot 25$; e) $125 \cdot 777 \cdot 80$.
- 276.** Qolayli' usi'l menen yesaplan':
 a) $3 \cdot 5 \cdot 2 \cdot 7$; b) $5 \cdot 5 \cdot 6 \cdot 4$; d) $7 \cdot 2 \cdot 2 \cdot 5 \cdot 5$;
 e) $2 \cdot 9 \cdot 5 \cdot 5$; f) $8 \cdot 4 \cdot 125 \cdot 25$; g) $4 \cdot 2 \cdot 25 \cdot 5 \cdot 8 \cdot 125$.
U'ligi: a) $3 \cdot 5 \cdot 2 \cdot 7 = (5 \cdot 2) \cdot (3 \cdot 7) = 10 \cdot 21 = 210$.
- 277.** Yeger $a = 1125$, $b = 225$ bolsa, $1034a - 934b$ an'latpasi'ni'n' ma'nisin tabi'n'.

- 278.** 1 kg konfet 5800 swm turadi'. a) 23 kg; b) 15 kg; d) 8 kg; e) 2 kg Konfeta qansha turadi'?
- 279.** AB kesindisinde C noqati' ali'ng'an. Yeger $AC = 9$ sm ha'm CB kesindisi AC kesindisinen 4 ma'rte uzi'n bolsa, AB kesindisinin' uzi'nli'g'i'n tabi'n'.
- 280.** Dana sin'lisi Nargizadan 7 jas u'lken. Woni'n' jasi' atasi'ni'n' jasi'nan 3 ma'rte kishi Yeger Nargiza 5 jasta bolsa, Danani'n' ha'm woni'n' atasi'ni'n' jasi'n tabi'n'.



- 281.** Ashrab birinshi ku'n kitapti'n' 27 betin woqi'di'. Wol yekinshi ku'ni kitapti'n' birinshi ku'nge qarag'anda 3 ma'rte ko'p betin woqi'di'. Wol yeki ku'nde kitapti'n' neshe betin woqi'g'an?
- 282.** Sayaxatshi' birinshi ku'ni 12 km jol ju'rdi. Wol yekinshi ku'ni birinshi ku'nge qarag'anda 2 ma'rte ko'p, u'shinshi ku'ni bolsa birinshi ku'nge qarag'anda 3 ma'rte ko'p jol basti'. Sayaxatshi' 3 ku'nde qansha arali'qti' basi'p wo'tken?
- 283.** Velosipedshi u'yinen ma'nzilge 6 km/saat tezlik penen ha'reketlenip 4 saatta jetip keldi. Yeger wol qayti'wda 2 km/saatqa asi'rsa, u'yine qansha waqi'tta qayti'p baradi'?
- 284.** Ko'beymelerdi sali'sti'ri'n':
a) $21 \cdot 64$ ha'm $38 \cdot 79$; b) $82 \cdot 19$ ha'm $69 \cdot 39$.
- 285.** A'mellerdi wori'nlan':
a) $204 \cdot 65 - 38 \cdot (71 - 36) + 419$; b) $(547 + 4333) \cdot 35 - 205 + 70 \cdot 5$;
d) $2948 - 18 \cdot (100 - 93) + 75$; e) $100001 - 11 \cdot (38 + 16) \cdot 6$.

U'yde wori'nlanatug'i'n ma'seleler



- 286.** Ko'beyme ko'rinishde jazi'n'.
a) $65 + 65 + 65$; b) $234 + 234 + 234 + 234 + 234$; d) $y + y + y + y + y + y + y$.
- 287.** 19 sani' 15 ma'rte artti'ri'lsa, qaysi' san payda boladi'?
- 288.** Ko'beymeni yesaplan'.
a) $35 \cdot 7$; b) $23 \cdot 91$; d) $307 \cdot 15$;
e) $3 \cdot 601 \cdot 2 \cdot 230$; f) $78 \cdot 1100$; g) $390 \cdot 143$.
- 289.** An'latpani'n' ma'nisin tabi'n':
a) $540 + 540 + 540 + 540 + 153$; b) $999 + 999 + 777 + 777 + 777$;
d) $352 + 352 + 352 + 352 + 352 + 230$; e) $1289 + 53 + 53 + 53 + 53 + 1289$.



- 290.** Ko'beytiwdin' gruppalar qa'siyetinen paydalani'p ko'beymeni yesaplan'.
a) $125 \cdot (8 \cdot 9815)$; b) $(500 \cdot 5) \cdot 4$; d) $4 \cdot (25 \cdot 725)$; e) $(102 \cdot 4) \cdot 25$.
- 291.** Qolayli' usi'l menen yesaplan':
a) $50 \cdot 651 \cdot 2$; b) $424 \cdot 50 \cdot 4$; d) $40 \cdot 443 \cdot 25$; e) $125 \cdot 395 \cdot 8$.
- 292.** $213 \cdot 45$ ko'beymeni yesaplan'. Na'tiyjeden paydalani'p, to'mendegi ko'beymelerdi tabi'n':
a) $2130 \cdot 45$; b) $2130 \cdot 450$; d) $21300 \cdot 4500$; e) $21300 \cdot 45000$.

293. 1 kg si'r 8500 swm turadi'. a) 13 kg; b) 5 kg si'r qansha swm turadi'?
294. ABC u'shmu'yeshliktin' AB ta'repi 36 mm ha'm wol BC ta'repinen 3 yese qi'sqa. Yeger u'shmu'yeshliktin' perimetri 225 mm bolsa, AC ta'repinin' uzi'nli'g'i'n tabi'n'.
295. Birinshi u'skenede 1 minutta 17, yekinshisinde bolsa 19 detal'g'a islew beriw mu'mkin. Yeger birinshi u'skene 13 minut ha'm yekinshi u'skene 15 minut isletilse, ja'mi neshe detal'g'a islew beriledi?
296. Birinshi jumi'sshi' bir ku'nde 57, yekinshi jumi'sshi' bolsa birinshi jumi'sshi'dan 12 kem buyi'm tayarlaydi'. Bul jumi'sshi'lar 5 ku'nde neshe buyi'm tayarlaydi'?
297. A'mellerdi wori'nlan':
a) $42 \cdot 25 - 18 \cdot (97 - 87)$; b) $(7542 + 3343) \cdot 15 - 170 \cdot 12$.
298. U'y sharayati'nda bir lampa energiyani' u'nemlewshi lampag'a almasti'ri'lsa bir ji'lda 53 kg ko'mir u'nemlenedi ha'm 105 kg za'ha'rli gazdi'n' atmosferag'a tarqali'wi'ni'n' aldi' ali'nadi'. Yeger 6 lampa almasti'ri'lsa she?



Matematika tariyx'i'na tiyisli u'zindiler

Al-Xorazmiy woylap tapqan ko'beytiwdin' tor usi'li'

Bul usi'ldi' IX a'sirde ulli' babami'z, ataqli' matematik ali'm Muha'mmed ibn Musa al-Xorazmiy woylap tapqan. Sanlardi' bul usi'lda ko'beytiw ushi'n ko'beytiwshiler sa'ykes tu'rde tuwri'mu'yeshlikti'n' to'be ha'm won' ta'repine jazi'lg'an. Ko'beyme bolsa to'meninde payda bolg'an.

To'mendegi bir neshe sanlar sol usi'lda ko'beytilgen. Ko'beytiw bari'si'n talqi'lan' ha'm woni' wori'nlaw qag'i'ydasi'n tabi'n'. Tabi'lg'an qag'i'ydani' keyingi bir neshe mi'sallarda qollap, ko'beymeni tabi'n'.

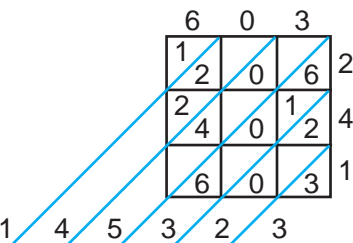
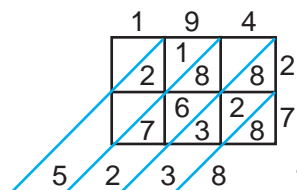
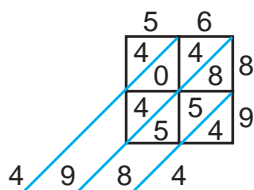

- a) $56 \cdot 89 = 4984$; b) $194 \cdot 27 = 5238$; d) $603 \cdot 241 = 145323$;
e) $28 \cdot 58 = \dots$; f) $234 \cdot 37 = \dots$; g) $593 \cdot 441 = \dots$

14- §.

NATURAL SANLARDI BO'LŠW

14.1. Natural sanlardi' bo'liw

1- mi'sal. 30 alma 6 ta'relkag'a ten' yetip bo'lindi. Ha'r bir ta'relkag'a neshe almadan sali'ng'an?

Sheshiliwi. Ha'r bir ta'relkag'a sali'ng'an almalar sani'n c penen belgileymiz. Wonda ma'sele sha'rti boyi'nsha, $c \cdot 6 = 30$ boladi'. Bizge belgili, $c = 5$ boladi', sebebi $5 \cdot 6 = 30$.

Demek, ha'r bir ta'relkag'a 5 almadan sali'ng'an.

Joqari'dag'i' ma'selede berilgen ko'beyme ha'm bir ko'beytiwshi boyi'nsha, yekinshi belgisiz ko'beytiwshini tapti'q. Bul bo'liw a'melinin' ma'nisin ashi'p beredi. Berilgen ko'beyme ha'm bir ko'beytiwshi boyi'nsha yekinshi ko'beytiwshini tabi'w a'meline *bo'liw* dep ataladi'.

Uli'wma jag'dayda

$$a : b = c$$

jazi'wda a – *bo'liniwshi*, b – *bo'liwshi* ha'm bo'liw na'tiyjesi c – *tiyindi* dep ataladi'.

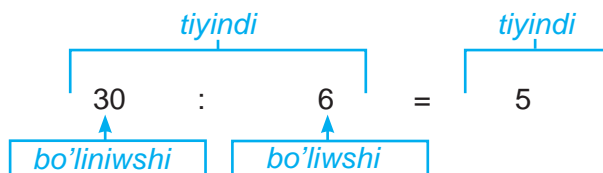

Tiyindi – bo'liniwshinin' bo'liwshiden *neshe ma'rte u'lkenligin*, ya'ki bo'liwshinin' *neshe ma'rte kishi yekenligin* bildiredi.

Ha'r qanday sandi' nolge bo'liw mu'mkin yemes!



$1 \cdot a = a$ bolg'ani' ushi'n, bo'liw a'melinin' ma'nisi boyi'nsha

$$a : 1 = a \quad \text{ha'm} \quad a : a = 1 \quad (a \neq 0).$$

Ha'r qanday sandi'1 ge bo'lgende ja'ne sol sannin' wo'zi payda boladi'



$0 \cdot a = 0$ bolg'ani' ushi'n bo'liw a'melinin' ma'nisi boyi'nsha

$$0 : a = 0.$$

Noldi ha'r qanday sang'a bo'lgende ja'ne nol payda boladi'



14.2. Bo'liw ya'ki ko'beytiwdin' duri's wori'nlang'anli'g'i'n tekseriw

Bo'liw a'meli na'tiyjesin ko'beytiw arqali tekseriw mu'mkin.

2-mi'sal. Aytayi'q bo'liw na'tiyjesinde $945 : 35 = 27$ payda bolg'an bolsi'n. Bo'liwdin' tuwri' wori'nlang'anlig'i'n bo'liw a'meli ma'nisinen kelip shi'g'i'p tekseremiz. Buni'n ushi'n bo'liwshi ha'm tiyindini wo'z ara ko'beytemiz. Yeger ko'beyme bo'liniwshige ten' bolsa, bo'liw duri's, keru jag'dayda naduri's wori'nlang'an boladi'.

Bizin' jag'dayda $35 \cdot 27 = 945$. Demek, bo'liw duri's wori'nlang'an.

Tap usi'g'an uqsas ko'beytiwdin' duri's wori'nlang'anli'g'i' ko'beymeni ko'beytiwshilerden birine bo'liw arqali' tekseriledi. Yeger tiyindi yekinshi ko'beytiwshige ten' shi'qsa, ko'beytiw duri's, kerisinshe bolsa naduri's boladi'.

Ma'selen, $24 \cdot 32 = 768$ ko'beytiwdin' duri's wori'nlang'anli'g'i' 768 di 24 ke bo'lgende 32 (ya'ki 768 di 32 ge bo'lgende 24) payda boli'wi' menen ani'qlanadi'.

14.3. Belgisiz ko'beytiwshini tabi'w

3- mi'sal. Ten'lemani sheshin': $7 \cdot x = 84$

Sheshiliwi. Bo'liw a'melinin' ma'nisi boyi'nsha $x = 84 : 7$, yag'ni'y $x = 12$.



Belgisiz ko'beytiwshini tabi'w ushi'n ko'beymeni yekinshi ko'beytiwshige bo'liw kerek.

$$\begin{aligned} a \cdot x &= b \\ x &= b : a \end{aligned}$$

14.4. Belgisiz bo'liniwshini tabi'w

4- mi'sal. Ten'lemani sheshin': $x : 12 = 7$

Sheshiliwi. Bo'liw a'melinin' ma'nisi boyi'nsha $x = 12 \cdot 7$, yag'ni'y $x = 84$.



Belgisiz bo'liniwshini tabi'w ushi'n tiyindini bo'liwshige bo'liw kerek.

$$\begin{aligned} x : c &= d \\ x &= d \cdot c \end{aligned}$$

14.5. Belgisiz bo'liwshini tabi'w

5- mi'sal. Tenglamani yeching: $96 : x = 16$

Sheshiliwi. Bo'liw a'melinin' ma'nisi boyi'nsha $x = 96 : 16$, yag'ni'y $x = 6$.



Belgisiz bo'liwshini tabi'w ushi'n bo'liniwshini tiyindige bo'liw kerek.

$$\begin{aligned} p : x &= q \\ x &= p : q \end{aligned}$$



Sorawlarg'a juwap berin'!

1. $a : b = c$ jazi'wi'ndag'i' ha'ripler qanday ataladi'?
2. Bo'liwdin' duri's wori'nlang'anli'g'i' qalay tekseriledi?
3. Bo'linma nimani anglatadi'?
4. Noma'lum bo'linuvchi qanday topiladi'?
5. Ko'beytiwdin' duri's wori'nlang'anli'g'i' qalay tekseriledi?

Klasta wori'nlanatug'i'n shi'ni'g'i'wlar



299. Yesaplan'.

- a) $9 : 3$; b) $18 : 6$; d) $30 : 2$; e) $75 : 3$;
 f) $45 : 3$; g) $54 : 2$; h) $24 : 2$; i) $24 : 3$.

300. Tu'sirip qaldi'ri'lg'an sandi' ayti'n'.

- a) $3 \cdot \dots = 36$; d) $10 \cdot \dots = 30$; f) $\dots : 3 = 13$; h) $50 : \dots = 2$;
 b) $2 \cdot \dots = 50$; e) $30 : \dots = 3$; g) $\dots : 50 = 2$; i) $99 : \dots = 9$.

301. Bo'liwdi wori'nlan'.

- a) $512 : 16$; b) $1980 : 36$; d) $1530 : 15$; e) $1050 : 15$;
 f) $3080 : 5$; g) $2106 : 39$; h) $15\ 655 : 31$; i) $31\ 108 : 44$.

302. Bo'liwdi wori'nlan'. Na'tiyjeni ko'beytiw arqali tekserin':

- a) $804 : 67$; b) $672 : 56$; d) $1224 : 12$; e) $1072 : 8$;
 f) $14 : 1$; g) $0 : 323$; h) $9450 : 18$; i) $1515 : 15$.

U'lg'i: a) Bo'liw ma'nisi boyi'nsha 67 ni 12 ge ko'beytsek, ko'beyme 804 ke ten' boli'wi' kerek. Haqi'yqati'nda da, $67 \cdot 12 = 804$. Bo'liw duri's wori'nlang'an.

303. Ko'beytiw na'tiyjesin bo'liw arqali' tekserin':

- a) $314 \cdot 75 = 23\ 550$; d) $601 \cdot 852 = 512\ 012$;
 b) $502 \cdot 104 = 52\ 208$; e) $1005 \cdot 212 = 213\ 060$.

U'lg'i: Ko'beymeni birinshi ko'beytiwshige bo'lsek, yekinshi ko'beytiwshi payda boli'wi' kerek. Haqi'yqattan da, $23\ 550 : 314 = 75$. Ko'beytiw duri's wori'nlang'an.

304. a) 441 559 sani' 109 sani'nan neshe ma'rte u'lken?

b) 306 sani' 674 730 sani'nan neshe ma'rte kishi?

305. Bir almani'n' massasi' neshe gramm? (1- su'wret)

a)

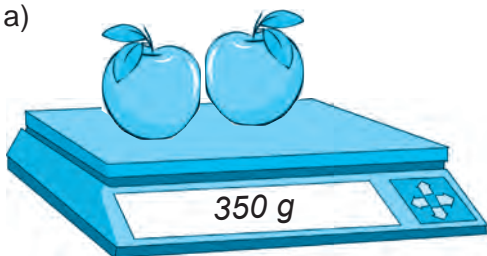

b)

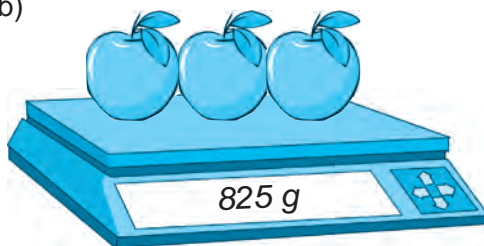

1-su'wret



306. Bo'liwdi "mu'yesh" usi'li'nan paydalanbastan wori'nlan'. Na'tiyjeni ko'beytiw ja'rdeminde tekserin':

- a) $254\ 254 : 254$; b) $363\ 636 : 36$; d) $656\ 565 : 13$;
 e) $90\ 045\ 015 : 15$; f) $600\ 900\ 300 : 30$; g) $350\ 175\ 070 : 35$.

307. $32\ 046 : 7 = 4578$ yekenliginen paydalani'p, to'mendegi tiyindilerdi tabi'n':
 a) $320\ 460 : 7$; b) $320\ 460 : 70$; d) $3\ 204\ 600 : 700$; e) $32\ 046\ 000 : 7000$.

308. Kesteni toltiri'n':

a	8	18	24		66	72	0	75
b	4	3	6	7			25	1
$a \cdot b$			144	245				
$a : b$			4		6	9		

U'ligi: $a = 24$ va $a \cdot b = 144$. Demek, $b = 144 : 24 = 6$, $a : b = 24 : 6 = 4$.

309. Yeger a) $a = 23712$, $b = 145$, $d = 31$; b) $a = 2730$, $b = 438$, $d = 412$ bolsa, $a : (b - d)$, an'latpani'n' ma'nisin tabi'n'.

310. a) 2880 sani'n ko'beytiwshilerden biri 45 bolg'an; b) 10323 sani'n ko'beytiwshilerden biri 111 bolg'an yeki san ko'beymesini ko'riniside su'wretlen'.

311. Yeki jumi'sshi' birgelikte islep 1456 stul jasadi'. Yeger birinshi jumi'sshi' bir ku'nde 32, yekinshisi bolsa 24 stul jasag'an bolsa, wolardi'n' ha'r biri ja'mi neshe stuldan jasag'an?



312. Yeger $945 : 35 = 27$ yekenligi belgili bolsa, to'mendegi an'latpalardi'n' ma'nisin tabi'n':

a) $27 \cdot 35$; b) $945 : 27$.

313. Belgisiz ko'beytiwshini tabi'n':

a) $18 \cdot x = 450$; b) $23 \cdot y = 2346$; d) $25 \cdot a = 20\ 200$; e) $356 \cdot n = 542\ 544$.

U'ligi: $30 \cdot x = 23\ 310$, $x = 23\ 310 : 30$, $x = 777$.

314. Belgisiz bo'liniwshini tabi'n':

a) $x : 4 = 207$; b) $y : 5 = 616$; d) $a : 29 = 31$; e) $b : 16 = 37$.

U'ligi: $x : 44 = 23$, $x = 44 \cdot 23$, $x = 1012$.

315. Belgisiz bo'liwshini tabi'n':

a) $360 : x = 45$; b) $861 : y = 41$; d) $1404 : m = 52$; e) $25760 : t = 230$.

U'ligi: $2052 : y = 38$, $y = 2052 : 38$, $y = 54$.

316. Ten'lemeni sheshin':

a) $21 \cdot x = 903$; b) $63 \cdot y = 2583$; d) $986 : m = 17$;

e) $8844 : n = 67$; f) $s : 824 = 437$; g) $t : 527 = 320$.

317. A'mellerdi wori'nlan':

a) $(6444 + 756) : 72$; b) $(3913 + 1313) : 13$;

d) $(1248 - 864) : 24$; e) $(9447 - 4747) : 47$.



U'yde wori'nlanatug'i'n ma'seleler

318. Bo'liwdi wori'nlan':

a) $945 : 21$; b) $345 : 15$; d) $1394 : 17$;

e) $1131 : 13$; f) $928 : 16$; g) $9234 : 38$.

- 319.** Yesaplan'. Na'tiyjeni ko'beytiw arqali' tekserin':
 a) $1140 : 76$; b) $972 : 18$; d) $4464 : 93$; e) $14280 : 21$.
- 320.** a) 23 562 sani' 231 sani'nan neshe ma'rte u'lken?
 b) 423 sani' 90 522 sani'nan neshe ma'rte kishi?
- 321.** Bir paliz wo'niminin' massasi' qansha? (2- su'wret)



2- su'wret



- 322.** Zafardi'n' qari'sii'ni'n' uzi'nli'gi' 16 sm. Uzi'nli'g'i' 192 sm bolg'an arqan Zafardi'n' qari'si' menen wo'lshense, neshe qari's shi'g'adi'?
- 323.** A'mellerdi wori'nlan':
 a) $27\ 440 \cdot 270$; b) $36\ 300 \cdot 8600$; d) $646\ 400 : 80$; e) $73\ 020\ 500 : 50$.
- 324.** 1887 sani'n ko'beytiwshilerdin' biri 37 bolg'an yeki san ko'beymesini ko'ri- nisinde su'wretlen.



- 325.** Bir banan neshe gramm?

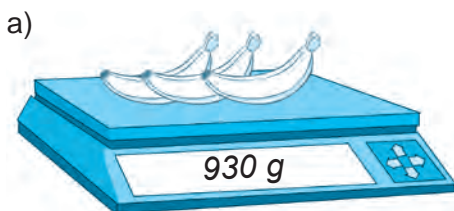

2- su'wret

- 326.** Ten'lemeni sheshin':
 a) $13 \cdot x = 208$; b) $104 \cdot a = 5720$; d) $532 \cdot m = 113\ 316$;
 e) $x : 29 = 134$; f) $a : 209 = 214$; g) $p : 103 = 871$.
- 327.** Ten'lemeni sheshin':
 a) $555 : x = 37$; b) $2730 : m = 65$; d) $30653 : s = 203$;
 e) $107 \cdot x = 4815$; f) $1904 : m = 34$; g) $s : 281 = 211$.

15- §.

QALDI'QLI' BO'LIW

14 g'ozani' u'sh kirpitikenge ten' bo'liw kerek bolsi'n. Bul jag'dayda ha'r bir kirpitikenge 4 g'ozadan tiyedi ha'm 2 g'ozada arti'p qaladi' (1-su'wret).

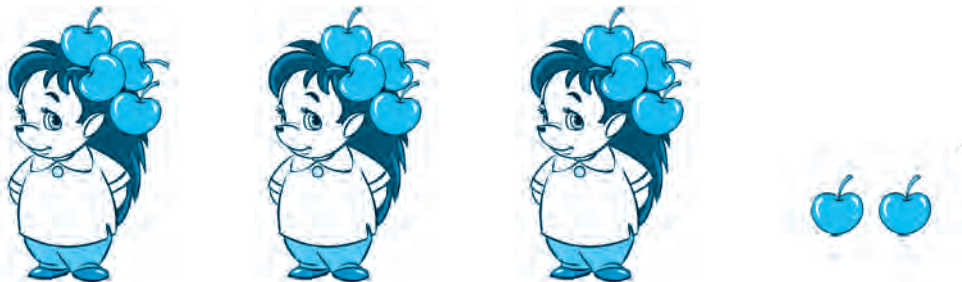

1- su'wret

Demek, 14 sani' 3 ke bo'linbeydi. Buni'

$$\begin{array}{r} -14 \overline{)3} \\ \underline{12} \\ 2 \end{array}$$

ya'ki

$$14 = 3 \cdot 4 + 2$$

ko'rinishinde an'lati'wg'a boladi'. Bul jag'dayda 14 sani' 3 ke *qaldi'qli' bo'linedi* delinedi ha'm 14 – *bo'liniwshi*, 3 – *bo'liwshi*, 4 – *toli'q emes tiyindi* ha'm 2 – *qaldi'q* dep ataladi'.

$$\begin{array}{r} -14 \overline{)3} \\ \underline{12} \\ 2 \end{array}$$

bo'liniwshi (arrow to 14)
bo'liwshi (arrow to 3)
toli'q emes tiyindi (arrow to 4)
qaldi'q (arrow to 2)

$$14 = 3 \cdot 4 + 2$$

bo'liniwshi (arrow to 14)
bo'liwshi (arrow to 3)
toli'q emes tiyindi (arrow to 4)
qaldi'q (arrow to 2)

1- su'wret



Barqulla qaldi'q bo'liwshiden kishi boladi'.

Haqi'yqati'nda da 2-su'wrette su'wretlengen qaldi'qli' bo'liwde qaldi'q 2, toli'q emes tiyindi 4 ten' kishi.

Joqari'dag'i' $14 = 3 \cdot 4 + 2$ ten'likten to'mendegi qag'i'ydani' payda yetemiz:



Qaldi'qli' bo'liwde bo'liniwshini tabi'w ushi'n, toli'q yemes tiyindini bo'liwshige ko'beytip, payda bolg'an ko'beymege qaldi'qti'qosi'w jetkilikli.

Yeger qaldi'q nolge ten' bolsa, bo'liniwshi bo'liwshige qaldi'qsi'z bo'linedi delinedi.



Sorawlarg'a juwap berin'!

1. Natural san yekinishine ha'r qashan qaldi'qsi'z bo'line me? Mi'sal keltirin'.
2. Bo'liwde qaldi'q bo'liwshiden u'lken boli'wi' mu'mkin be?
3. $27 = 6 \cdot 4 + 3$ sanli' an'latpada qatnasqan ha'r bir san qanday at penen ataladi'?
4. Qaldi'qsi'z tiyindi, bo'liwshi ha'm qaldi'qqa ko're bo'liniwshi qanday tabi'ladi'?

Klasta wori'nlanatug'i'n shi'ni'g'i'wlar



328. To'mendegi berilgen sanlardan birinshisi yekinishisine qaldi'si'z bo'lineme?
 a) 9 ha'm 3; b) 12 ha'm 5; d) 18 ha'm 6; e) 20 ha'm 8; f) 0 ha' m 34; g) 124 ha'm 5.

329. Sandi' 8 ge bo'lgende a) 0 b) 2 d) 5 e) 7 f) 12 qaldi'q qali'wi' mu'mkinbe?

330. Sanlardi' a) 2 ge; b) 7 ge; d) 11 ge; e) 15 ke bo'lgende, qaldi'q neshe boli'wi' mu'mkin?

331. Bir ko'rpeni tigiwge 6 m gezleme sari'planadi'. 200 m gezlemeden qansha ko'rpe tigiw mu'mkin? Sonda qansha gezleme arti'p qaladi'?

332. Qaldi'qli' bo'liwdi wori'nlan':

- a) 546 : 5; b) 308 : 7; d) 210 : 19;
 e) 1230 : 7; f) 12655 : 63; g) 54103 : 44.

333. Ten'likti qaldi'qli' bo'liw arqali' tekserin'. Bo'liniwshi, bo'liwshi, toli'qsi'z tiyindi ha'm qaldi'qti' ayti'n':

- a) $2053 = 84 \cdot 24 + 37$; b) $4106 = 79 \cdot 51 + 77$;
 d) $2891 = 1000 \cdot 2 + 891$; e) $1230 = 94 \cdot 13 + 8$.



334. Sonday sanlardi' tabi'n', woni':

- a) 32 ge bo'lgende, 24 payda boli'p, 13 qaldi'q qals i'n;
 b) 43 ke bo'lgende, 25 payda boli'p, 17 qaldi'q qalsi 'n;
 d) 119 g'a bo'lgende, 31 payda boli'p, 29 qaldi'q qal si'n.

U'lg'i: a) qaldi'qli' bo'liwde bo'liniwshini tabi'w ushi'n toli'q yemes tiyindini bo'liwshige ko'beytip, payda bolg'an ko'beymege qaldi'qti' qosi'w kerek yekenligi belgili. Demek, izlenip ati'rg'an san $32 \cdot 24 + 13$ ke yag'ni'y 78 1 ge ten' bol adi'.

335. Ji'ynalg'an 770 t biyday qi'rmani' temir jol arqali' un zavodqa tasi'w kerek. Ha'r bir ju'k vagong'a 60 t biyday si'yadi'. Barli'q wo'nimdi zavodqa tasi'w ushi'n neshe ju'k vagoni' kerek boladi'? Aqi'rg'i' vagong'a qansha biyday ju'klenedi?

336. Mektep ja'ma'a'ti ha'r bir pitkeriwshi woqi'wshi'g'a sawg'a yetiw ushi'n 370 dana gu'l sati'p aldi'. Ha'r bir woqi'wshi'g'a 3 danadan gu'l berildi ha'm 1 dana gu'l awi'si'p qaldi'. Mektepti pitkeriwshi woqi'wshi'lardi'n' sani' qansha?

337. Kesteni tolti'ri'n':

Bo'liniwshi	Bo'liwshi	Toli'q yemes tiyindi	Qaldi'q
837	73		
721		45	
	43	71	27

338. Bati'r kempir apasi'ni'n' 55 jasli'q yubeleyine gu'lda'ste sawg'a yetiw ushi'n gu'l bazardan 55 dana gu'l sati'p aldi'. Gu'lda'ste ushi'n Bati'r sati'wshi'g'a 10 000 swm pul berdi. Sati'wshi' bolsa wog'an 100 swm qaytardi'. Bir dana gu'ldin' bahasi' qansha?

339. Ko'beyiwdi qolayli' usi'l menen wori'nlan':

- a) $39 \cdot 25 \cdot 4$; d) $134 \cdot 5 \cdot 20$; f) $33 \cdot 125 \cdot 8$;
 b) $40 \cdot 239 \cdot 25$; e) $56 \cdot 50 \cdot 20$; g) $134 \cdot 250 \cdot 4$.

340. A'mellerdi wori'nlan':

- a) $130\ 536 : 444 - 5829 : 87 + 58\ 606$; b) $14 \cdot (3600 \cdot 18 - 239\ 200 : 46)$.



U'yde wori'nlanatug'i'n ma'seleler

341. Quti'dag'i' 10 kg shay 150 g nan yetip qadaqlanadi'. Qadaqlang'annan son' quti'da qansha shay qaldi'?
342. Shiyirinnin' 5000 swm puli' bar. Wol bul pulg'a bahasi' 450 swm bolg'an muzqaymaqtan ko'bi menen neshewin sati'p ali'w mu'mkin? Shiyirinnin' sonda ja'ne neshe swm puli' awi'si'p qaladi'?
343. Qaldi'qli' bo'liwdi wori'nlan':
- a) 398 : 13; b) 271 : 18; d) 1342 : 43;
e) 5620 : 67; f) 33 655 : 234; g) 10 354 : 233.



344. Sonday sandi' tabi'n', woni':
- a) 44 ke bo'lgende, 39 payda boli'p, 36 qaldi'q qa lsi'n;
b) 123 ke bo'lgende, 66 payda boli'p, 100 qaldi'q qalsi'n;
345. Baqshag'a mashinada 200 l su't keltirildi. Su'tti quyip ali'w ushi'n ko'lemi 32 l bolg'an bitonlardan qanshasi' kerek boladi'? Aqi'rg'i' bitong'a qansha su't quyiladi'?
346. Kesteni toltiri'n':

Bo'liniwshi	Bo'liwshi	Toli'q yemes tiyindi	Qaldi'q
3425	89		
22 340		171	
	281	77	23

347. Zavod skladi'ndag'i' 15 t 750 kg paxta 155 kg nan yetip taqlandi'. Taqlang'an paxtadan qansha dana payda boldi'? Skladta ja'ne qansha paxta awi'si'p qaldi'?
348. Qaysi' halda arzan sati'p ali'w mu'mkin?

1 kg
4 500 swm

2 kg
8 500 swm



Bilimin'izdi si'nap ko'rin'!

Bul bap materiallari'ni' u'yrenip shi'qi'p, to'mendegi ma'selelerdi sheshe ali'wi'n'i'z sha'rt. Tekseriw jumi'si' aldi'nan wo'zin'izdi si'nap ko'rin'.

4- tekseriw jumi'si' u'lgisi

- Yesaplan':
a) $67 \cdot 189$; b) $306 \cdot 805$; d) $38\ 130 : 186$.
- Ten'lemeni sheshin':
a) $x \cdot 13 = 182$; b) $187 : y = 17$.
- Qolayli' usi'l menen yesaplan':
a) $4 \cdot 283 \cdot 25$; b) $7 \cdot 137 \cdot 125$; d) $50 \cdot 31 \cdot 20$.
- Ma'seleni ten'leme du'zip sheshin':
Maryam bir san woyladi'. Woni' 4 ke ko'beytip, ko'beymege 8 di qosti'. Na'tiyjede 60 payda bo'ldi'. Maryam qanday sandi' woylag'an?
- Tenlemenin' koreni tabi'n': $y - 25 = 10$.

16- §.

AN'LATPALARDI' A'PIWAYI'LASTI'RIV

Aktivlestirivshi shi'ni'g'i'w

Mi'sal. Juwi'ni'w xanasi' poli' 4 qatar yeki tu'rli ren'degi plitkalar menen qaplandi' (1-su'wret). Ha'r bir qatarg'a 3 qi'zi'l ha'm 5 aq ren'degi plitkalar wornati'lg'an. Juwi'ni'w xanasi' poli'na neshe plitka jatqi'zi'lg'an?

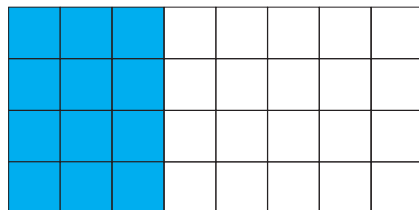

1-su'wret

Sheshiliwi. Bul ma'seleni yeki usi'l menen sheshiw mu'mkin.

1-usi'l. Aldi'n ha'r bir qatarg'a wornati'lg'an plitkalar sani'n ani'qlaymi'z: $3 + 5$. Son' qosi'ndi'ni' qatarlar sani' 4 ke ko'beytemiz:

$$(3 + 5) \cdot 4 = 8 \cdot 4 = 32.$$

1-usi'l. Aldi'n ja'mi wornati'lg'an qi'zg'i'sh ha'm aq plitkalar sani'n ani'qlaymi'z:

Qi'zg'i'sh ren'li plitkalar – $3 \cdot 4$ ta,

Aq ren'li plitkalar – $5 \cdot 4$ ta.

Son' wolardi' qosami'z:

$$3 \cdot 4 + 5 \cdot 4 = 12 + 20 = 32.$$

Ha'r yeki jag'day da juwap birdey: Juwi'ni'w xanasi' poli'na ja'mi 32 plita jatqi'zi'lg'an.

16.1. Ko'beytiwdin' qosi'wg'a qarata bo'listiriv ni'zami'

Joqari'dag'i' ma'seleni yeki usi'lda sheship

$$(3 + 5) \cdot 4 = 3 \cdot 4 + 5 \cdot 4$$

yekenligin ani'qladi'q.

Qosi'ndi'ni' sang'a ko'beytiw ushi'n qosi'li'wshi'lardi'n' ha'r birin bul sang'a ko'beytiw ha'm payda bolg'an ko'beymelerdi qosi'w jetkillikli.

Bul qa'siyet *ko'beytiwdin' qosi'wg'a qarata bo'listiriv ni'zami'* dep ayti'ladi'. Ha'ripler ja'rdeminde bul ni'zam

$$(a + b) \cdot c = a \cdot c + b \cdot c$$

ko'rinishinde an'lati'ladi'.

Ko'beytiwdin' qosi'wg'a qarata bo'listiriv ni'zami' qa'legen sandag'i' qosi'li'wshi'lar ushi'n da wori'nli' boladi'.

16.2. Ko'beytiwdin' ali'wg'a qarata bo'listiriv ni'zami'

$(8 - 3) \cdot 4$ ha'm $8 \cdot 4 - 3 \cdot 4$ an'latpani'n' ma'nisi de bird ey s ang'a ten':

$$(8 - 3) \cdot 4 = 5 \cdot 4 = 20, \quad 8 \cdot 4 - 3 \cdot 4 = 32 - 12 = 20.$$

Demek,

$$(8 - 3) \cdot 4 = 8 \cdot 4 - 3 \cdot 4.$$

Ali'wdi' sang'a ko'beytiw ushi'n azayi'wshi' ha'm ali'ni'wshi' bo'lek-bo'lek usi' sang'a ko'beytiw ha'm birinshi ko'beymeden yekinishin ali'w jetkillikli.

Bul qa'siyet *ko'beytiwdin' ali'wg'a qarata bo'listiriv ni'zami'* dep ayti'ladi'.

Woni' ha'ripler menen

$$(a - b) \cdot c = a \cdot c - b \cdot c$$

ko'riniside an'latiladi'.

Ko'beytiwdin' qosi'wg'a qarata bo'listiriv ni'zami' qa'legen sandag'i' qosi'li'wshi'lar ushi'n da wori'nli' boladi'.

- 1-mi'sal. a) $62 \cdot 7 = (60 + 2) \cdot 7 = 60 \cdot 7 + 2 \cdot 7 = 420 + 14 = 434$;
 b) $59 \cdot 6 = (60 - 1) \cdot 6 = 60 \cdot 6 - 1 \cdot 6 = 360 - 6 = 354$.

16.3. Qawsir'malardi' ashi'w qag'i'ydas'i'

Ko'beytiwdin' qosi'w ha'm ali'wg'a qarata bo'listiriv ni'zami'n $(a + b) \cdot c$ ha'm $(a - b) \cdot c$ an'latpalari'na qollap, qawsir'malar qatnaspag'an an'latpalardi' payda yetemiz. Bul jumi'sti' **qawsir'malardi' ashi'w** dep ataymi'z.

- 2- mi'sal. $4 \cdot (x + 3)$ an'latpasi'ndag'i' qawsir'mani' ashsaq:
 $4 \cdot (x + 3) = 4 \cdot x + 4 \cdot 3 = 4x + 12$ ni payda yetemiz.

16.4. Uli'wma ko'beytiwshini qawsir'madan si'rtqa shi'g'ari'w qag'i'ydas'i'

$$(a + b) \cdot c = a \cdot c + b \cdot c \quad \text{ha'm} \quad (a - b) \cdot c = a \cdot c - b \cdot c$$

ten'lemelerdin' sol bo'liminen won' bo'limine wo'tkenimizde – qawsir'ma qatnaspag'an an'latpalardi' payda yetemiz. Bul ten'likler **qawsir'malardi' ashi'w** qag'i'ydas'i'n an'latadi'.

- 3- mi'sal. $4 \cdot (x + 3)$ an'latpada qawsir'malardi' ashsaq:
 $4 \cdot (x + 3) = 4 \cdot x + 4 \cdot 3 = 4x + 12$ ni payda yetemiz.

$(a + b) \cdot c = a \cdot c + b \cdot c$ ha'm $(a - b) \cdot c = a \cdot c - b \cdot c$ ten'liklerdin' shep ha'm won' bo'limidegi an'latpalardi'n' worni'n almasti'rami'z. Na'tiyjede
 $a \cdot c + b \cdot c = (a + b) \cdot c$ ha'm $a \cdot c - b \cdot c = (a - b) \cdot c$
 tengliklerin payda yetemiz.

Bul ten'likler **uli'wma ko'beytiwshini qawsir'madan si'rtqa shi'g'ari'w** qag'i'ydas'i'n an'latadi'.

- 4- mi'sal. $5x + 2x$ an'latpa uli'wma ko'beytiwshi x ti' qawsir'madan si'rtqa shig'arsaq:

$$5x + 2x = (5 + 2) x = 7x \quad \text{payda boladi.}$$

Usi'g'an uqsag'an uli'wma ko'beytiwshini qawsir'madan si'rtqa shi'g'ari'wg'a baylani'sli' to'mendegi mi'sallardi' da keltiriv mu'mkin:

- 5- mi'sal. a) $38 \cdot 7 + 12 \cdot 7 = (38 + 12) \cdot 7 = 50 \cdot 7 = 350$;
 b) $29 \cdot 7 - 19 \cdot 7 = (29 - 19) \cdot 7 = 10 \cdot 7 = 70$;
 d) $13 \cdot 8 + 14 \cdot 18 + 17 \cdot 8 - 14 \cdot 8 = (13 + 17) \cdot 8 + 14(18 - 8) = 30 \cdot 8 + 14 \cdot 10 = 240 + 140 = 380$.

An'latpalardi' a'piwayi'lasti'ri'w ten'lemelerdi sheshiwdi an'satlasti'radi'.

- 6- misol. Ten'lemeni sheshi'n': $8x + 3x + 21 = 43$.

Sheshiliwi: $8x + 3x = 11x$ bolg'ani' ushi'n ten'lemeni to'mendegishe jazi'p ali'w mu'mkin: $11x + 21 = 43$.

Wonnan $11x = 43 - 21$ yaki $11x = 22$ ten'lemege kelemiz. Woni sheshi'p, $x = 22 : 11$ yaki $x = 2$ yekenligin tabami'z.

Soni'n' menen birge, an'latpalardi' a'piwayi'lasti'rwda ko'beytiwdin'gruppalam ni'zami'nan da paydalani'ladi'.

Ma'selen, $2x \cdot 5 \cdot 6$ an'latpani' $(2 \cdot 5 \cdot 6) x$ yaki $60x$ dep jazi'w mu'mkin.

$8x + 3x + 21 = 43,$
$11x + 21 = 43,$
$11x = 43 - 21,$
$11x = 22,$
$x = 22 : 11,$
$x = 2.$

16.5. Ma'seleler sheshiwde an'latpalardi' a'piwayi'lasti'ri'w usi'llari'nan paydalani'w

Tekstli ma'selelerdi ten'leme du'zip sheshiwde an'latpalardi' a'piwayi'lasti'ri'w usi'llari'nan ken' paydalani'ladi'. Buni' to'mendegi ma'selelerdi sheshiwde ko'riw mu'mkin:

7- mi'sal. Yeki ku'nde 220 kg qulpi'nay terildi. Yekinshi ku'ni birinshi ku'nge qarag'anda 3 ma'rte ko'p qulpi'nay terildi. Birinshi ku'ni qansha qulpi'nay terilgen?

Sheshiliwi: Birinshi ku'ni terilgen qulpi'nay massasi'n x penen belgileymiz.

Wonda ma'sele sha'rti boyi'nsha, ekinshi ku'ni terilgen qulpi'nay massasi'n $3x$ ge ten' boladi' ha'm wolardi'n' qosi'ndi'si' 220 g'a ten' boladi'.

Demek, $x + 3x = 220$ ten'lemesine iye bolami'z.

Woni' sheshemiz: $4x = 220$, $x = 220 : 4$, $x = 55$.

Juwabi': 1- ku'ni 55 kg qulpi'nay terilgen.

$$\begin{aligned} 1- \text{ kun: } & \quad x \\ 2- \text{ kun: } & \quad 3x \end{aligned} \quad \left. \vphantom{\begin{aligned} 1- \text{ kun: } \\ 2- \text{ kun: } \end{aligned}} \right\} 220 \text{ kg}$$

$$\begin{aligned} x + 3x &= 220, \\ 4x &= 220, \\ x &= 220 : 4, \\ x &= 55. \end{aligned}$$

Juwabi': 55 kg.

8- mi'sal. 2 yese sari' ha'm 3 yese ko'k boyawlar aralasti'ri'li'p, jasi'l ren'li boyaw tayarladi'. 1500 g jasi'l ren'li tayarlaw ushi'n qansha sari' ren'li boyaw kerek boladi'?

Sheshiliwi: Bir u'les boyaw massasi'n x penen belgileymiz. Wonda ma'sele sha'rtine qaray, bir yese boyaw massasi'n x penen belgileymiz. Wonda

ma'sele sha'rti boyi'nsha, jasi'l ren'li boyaw qurami'ndag'i' sari' ren'li boyaw massasi'n $2x$, ko'k ren'li boyaw massasi'n $3x$ qa ten' boli'p, wolardi'n' qosi'ndi'si' 1500 ge ten' boladi'.

Demek, $2x + 3x = 1500$ ten'lemesine iye bolami'z.

Woni' sheshemiz: $5x = 1500$, $x = 1500 : 5$, $x = 300$.

Wonda, sari' ren'nin' massasi' $2x = 2 \cdot 300 = 600$ (g) bo'ladi.

Juwabi': Sari' ren'nen 600 g kerek boladi'.

$$\begin{aligned} \text{Sari':} & \quad 2x \\ \text{Ko'k:} & \quad 3x \end{aligned} \quad \left. \vphantom{\begin{aligned} \text{Sari':} \\ \text{Ko'k:} \end{aligned}} \right\} 1500 \text{ g}$$

$$\begin{aligned} 2x + 3x &= 1500, \\ 5x &= 1500, \\ x &= 1500 : 5, \\ x &= 300, \\ 2x &= 2 \cdot 300 = 600. \end{aligned}$$

Juwabi': 600 g.

Sorawlarg'a juwap berin'!



1. Ko'beytiwdin' qosi'wg'a baylani'sli' bo'listiriv ni'zami'n mi'sallarda tu'sindirin'.
2. $(a - b) \cdot c = a \cdot c - b \cdot c$ jazi'wi' qaysi' ni'zamdi' an'latadi'?
3. Uli'wma ko'beytiwshini qawsi'rmadan si'rtqa shi'g'ari'wdi' mi'sallarda
4. tu'sindirin'.
5. $(a + b) \cdot c$ an'latpasi'nda qawsi'rmalardi' ashi'w ushi'n qaysi' ni'zamnan paydalani'w kerek?



Klasta wori'nlanatug'i'n shi'ni'g'i'wlar

349. Qaysi' yesaplaw usi'li' qolayli':

a) $(100 + 40) \cdot 9 = 140 \cdot 9 = \dots$ ya'ki $(100 + 40) \cdot 9 = 100 \cdot 9 + 40 \cdot 9 = \dots?$

b) $8 \cdot (40 - 1) = 8 \cdot 39 = \dots$ ya'ki $8 \cdot (40 - 1) = 8 \cdot 40 - 8 \cdot 1 = \dots?$

350. Yesaplan':

a) $7 \cdot (10 + 4);$

b) $9 \cdot (100 + 10);$

d) $8 \cdot (90 + 1);$

e) $4 \cdot (30 + 100);$

f) $6 \cdot (20 + 7);$

g) $5 \cdot (100 - 3).$

351. Ko'beytiwdin' bo'listiriv ni'zami'nan paydalani'p, ko'beymeni qolayli' usi'lda yesaplan':

a) $51 \cdot 7;$

b) $299 \cdot 4;$

d) $24 \cdot 11;$

e) $3 \cdot 71;$

f) $4 \cdot 701;$

g) $505 \cdot 6.$

U'lgi: a) $51 \cdot 7 = (50 + 1) \cdot 7 = 50 \cdot 7 + 1 \cdot 7 = 350 + 7 = 357.$

352. Qandayda bir sandi' 15 ke ko'beytiwdi an'sat wori'nlawg'a da boladi'. Buni'n' ushi'n sandi' 10 g'a ko'beytip, ko'beymege payda bolg'an sanni'n' yari'mi'n qosi'p qoyi'w jetkilikli:

$34 \cdot 15 = 34 \cdot (10 + 5) = 34 \cdot 10 + 34 \cdot 5 = 340 + 170 = 510.$

Bul usi'ldan paydalani'p to'mendegi ko'beymelerdi yesaplan':

a) $66 \cdot 15;$

b) $160 \cdot 15;$

d) $42 \cdot 15;$

e) $640 \cdot 15.$

353. Qawsir'malardi' ashi'n':

a) $5 \cdot (x + 3);$

b) $(6 + x) \cdot 2;$

d) $4 \cdot (x - 8);$

e) $(y - 7) \cdot 3;$

f) $12 \cdot (c + 8);$

g) $(4 - y) \cdot 5.$

354. An'latpani' a'piwayi'lasti'ri'p woni'n' ma'nisin tabi'n':

a) $23a + 13a$, bunda $a = 9;$

b) $34b - 17b$, bunda $b = 19.$

355. U'sh xanali' sandi' 1001 ge ko'beytiw ushi'n woni'n' qasi'na ja'ne sol sanni'n' wo'zin jazi'w jetkilikli. Bul ni'zamdi' a) $321 \cdot 1001;$ b) $478 \cdot 1001;$ d) $905 \cdot 1001$ mi'sallar menen tekserip ko'rin' ha'm woni'n' duri's yekenligin da'lillen'.

U'lgi: $639 \cdot 1001 = 639 \cdot (1000 + 1) = 639 \cdot 000 + 639 = 639 \cdot 639.$



356. An'latpadagi' uli'wma ko'beytiwshini qawsir'madan si'rtqa shi'g'ari'p, woni'n' ma'nisin tabi'n':

a) $81 \cdot 21 + 19 \cdot 21;$

b) $252 \cdot 80 - 252 \cdot 70;$

d) $201 \cdot 91 + 112 \cdot 91;$

e) $696 \cdot 24 - 696 \cdot 14;$

f) $53 \cdot 17 + 32 \cdot 17;$

g) $23 \cdot 99 - 23 \cdot 51.$

U'lgi: a) $81 \cdot 21 + 19 \cdot 21 = (81 + 19) \cdot 21 = 100 \cdot 21 = 2100.$

357. An'latpadagi' uli'wma ko'beytiwshini qawsir'madan si'rtqa shi'g'ari'p, woni' ko'beyme tu'rinde an'lati'n':

a) $15x + 34x;$

b) $49x - 24x;$

d) $100x - x;$

e) $89b - 39b;$

f) $999x + x;$

g) $597p - 197p.$

U'lgi: a) $15x + 34x = (15 + 34) \cdot x = 49x.$

358. An'latpani'n' ma'nisin tabi'n':

a) $72a + 32b$, bunda $a = 9$ ha'm $b = 12$;

b) $77p + 45q$, bunda $p = 23$ ha'm $q = 51$.

359. a) 54; b) 31; d) 86 sani'n 101 ge ko'beytin'. Na'tiyjelerge tiykarlani'p yeki tan'balli' sandi' 101 ge awi'zeki ko'beytiw ni'zami'n jazi'n' ha'm da'lillen'.

U'lgi: $63 \cdot 101 = 63 \cdot (100 + 1) = 63 \cdot 100 + 63 = 6300 + 63 = 6363$.

360. Yeger tuwri'mu'yeshliktin' perimetri 390 sm bolsa, 2-su'wrettegi mag'li'w-matlardan paydalani'p woni'n' ta'replerin tabi'n'.

361. An'latpani' a'piwayi'lasti'ri'n':

a) $5x + 23 + 4x + 1$;

b) $12y + 31 + 34y + 8$;

d) $72 + 23p + 30 + 44p + 1$;

e) $55d + 23 + 45 + 45d$.



362. Ten'lemeni sheshin':

a) $3x + 4x + 17 = 24$;

b) $8y + 56 + 4y = 80$;

d) $11p - 4p - 25 = 24$;

e) $18d + 5d - 23 = 23$.

363. Yeki ku'nde 2350 kg kartoshka terildi. Yekinshi ku'ni birinshi ku'nge qarag'anda 4 ma'rte ko'p kartoshka terildi. Birinshi ku'ni qansha kartoshka terilgen?

U'lgi: Joqari'da ko'rilgen 6-mi'sal.

364. 3-su'wrettegi qaysi' jag'dayda arzan sawda a'melge asi'ri'ladi'?

The diagram shows a rectangle on the left with a horizontal dimension of $8x$ and a vertical dimension of $5x$. Below it is the label "2-su'wret". To the right, there are two shirts. The first shirt has a price tag that says "1 danasi' 15 800 swm". The second shirt has a price tag that says "2 danasi' 31 000 swm". Below the shirts is the label "3-su'wret".

365. 5 yese suwg'a 2 yese duz qosi'p aralaspa payda yetildi. 14 kg aralaspa payda yetiw ushi'n qansha duz kerek boladi'?

U'lgi: Joqari'da ko'rilgen 7-mi'sal.

366. Muzqaymaqi'n' 7 bo'legi su't, 2 bo'legi sari'may ha'm 2 bo'legi qumshekerden ibarat. 1 kg 210 g muzqaymaq tayarlaw ushi'n qansha su't kerek boladi'?

367. 7 qatardi'n' ha'r birine 24 pomidor na'li yegildi. Son' bul qatarlardi'n' ha'r birine ja'ne 8 qosi'msha na'l yegildi. Ja'mi neshe tu'p na'l yegilgen?

368. Saodat bir san woyladi'. Woni' aldi'n 15 ke ko'beytti, son' woni' wo'z aldi'na ja'ne 45 ge ko'beytti. N'atijelerdi qosqanda 1500 payda boldi'. Saodat qaysi' sandi' woylag'an?



U'yde wori'nlanatug'i'n ma'seleler

- 369.** Ko'beytiwdin' bo'listiriv ni'zamlari'nan paydalani'p, ko'beymeni qolayli' usi'lda yesaplan':
 a) $71 \cdot 9$; b) $39 \cdot 9$; d) $15 \cdot 61$; e) $5 \cdot 52$; f) $3 \cdot 901$; g) $701 \cdot 12$.
- 370.** Qawsir'malardi' ashi'n':
 a) $9 \cdot (5x + 2)$; b) $7 \cdot (9x - 11)$; d) $5 \cdot (7c + 3)$;
 e) $(10 + 7x) \cdot 6$; f) $(3y - 5) \cdot 3$; g) $(9 - 5y) \cdot 8$.
- 371.** An'latpalardi'n' ma'nisin tabi'n':
 a) $12a + 51b$, bunda $a = 11$ va $b = 23$; b) $59p - 23q$, bunda $p = 13$ va $q = 22$.
- 372.** Sandi' 5 ke ko'beytiw ushi'n woni'n' won' ta'repine bir nol qoyi'w ha'm payda bolg'an sandi' 2 ge bo'liw jetkilikli. Haqi'yqattan da, buni' to'mendegi mi'salda da ko'riw mu'mkin:

$$528 \cdot 5 = 528 \cdot (10 : 2) = (528 \cdot 10) : 2 = 5280 : 2 = 2640.$$

Bul ni'zamnan paydalani'p, ko'beymeni yesaplan':

- a) $248 \cdot 5$; b) $374 \cdot 5$; d) $213 \cdot 124 \cdot 5$; e) $8 \cdot 746 \cdot 307 \cdot 5$; f) $130 \cdot 379 \cdot 5$.

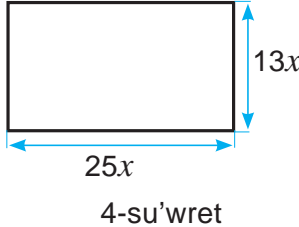

- 373.** An'latpadagi' uli'wma ko'beytiwshini qawsir'madan si'rtqa shi'g'ari'p, woni'n' ma'nisin tabi'n':
 a) $76 \cdot 29 + 14 \cdot 29$; d) $37 \cdot 13 + 28 \cdot 77 + 63 \cdot 13 - 18 \cdot 77$;
 b) $678 \cdot 88 + 678 \cdot 12$; e) $261 \cdot 12 + 29 \cdot 101 + 60 \cdot 12 - 17 \cdot 101$.
- 374.** Ko'beyme ko'rinisinde ko'rsetin':
 a) $76x + 55x$; d) $98x - 65x$; f) $1000p - p$;
 b) $13y + 65y$; e) $43b - 32b$; g) $999n + n$.
- 375.** Yeger tuwri' to'rtmu'yeshlikтин' perimetri 4712 mm bolsa, 4- su'wrettegi mag'liwmatlardan paydalani'p, woni'n' a'replerin tabi'n'.
- 
- 376.** An'latpani' a'piwayi'lasti'ri'n':
 a) $7x + 43 + 6x + 15$ b) $65y + 30 + 35y + 8$;
 d) $109 + 49p + 28 + 71p$; e) $128d + 523 + 477 + 120d$.



- 377.** Ten'lemeni sheshin':
 a) $21x + 16x + 55 = 166$; b) $81y + 60 + 9y = 960$;
 d) $59p - 19p + 125 = 565$; e) $58d + 37d + 212 = 972$.
- 378.** Biyday digirmanda tarti'lg'anda 6 u'les un ha'm 2 u'les kepek payda boladi'. 560 tonna biydaydan qansha un ali'nadi'?
- 379.** Shishe tayarlaw ushun 25 qi'sm qum, 9 qi'sm soda ha'm 5 qi'sm ha'k qollani'ladi'. 7 kg 800 g shisha tayarlaw ushun qansha qum kerek boladi'?
- 380.** Jumi'sshi' 1 saatta 17 detal, sha'kirti bolsa 12 detal tayarlaydi'. Wolar 7 saat dawami'nda birgelikte qansha detal tayarlaydi'?

17- §.

NATURAL SANLAR U'STINDE TO'RT A'MELGE TIYISLI MA'SELELER SHESHIW. A'MELLERDI WORINLAW TA'RTIBI

17.1. A'mellerdi wori'nlaw ta'rtibi

Qosi'w ha'm ali'w I basqi'sh, ko'beytiw ha'm bo'liw bolsa II basqi'sh a'melleri dep jurgiziladi.

An'latpani'n' ma'nisin tabi'wda a'mellerdi wori'nlaw ta'rtibi to'mendegi qag'i'ydalar tiykari'nda ani'qlanadi':

1- qag'i'йда. Yeger an'latpada qawsi'rmalar bolmasa, tek g'ana bir basqi'sh a'melleri qatnassa, a'meller shepten won'g'a qarap jazi'li'w ta'rtibinde izbe-iz wori'nlanadi'.

1-mi'sal. $762 - 413 + 381 - 256$ an'latpani'n' ma'nisin tabi'n'.

Sheshiliwi. Bul an'latpada qawsi'rmalar joq ha'm tek I basqi'sh a'melleri qatnasi'p ati'r. Demek, 1-qag'i'ya boyi'nsha a'mellerdi soldan won'g'a jazi'li'w ta'rtibinde izbe-iz wori'nlanadi'. A'mellerdi wori'nlaw ta'rtip cifri' a'meller u'stine jazi'lg'an:

$$\begin{array}{ccccccc} \textcircled{1} & \textcircled{2} & \textcircled{3} & & \textcircled{2} & \textcircled{3} & & \textcircled{3} \\ 762 - 413 + 381 - 256 = & \underline{349} + 381 - 256 = & \underline{730} - 256 = & 474. \end{array}$$

Juwabi': An'latpani'n' ma'nisi 474 ke ten'.

2- mi'sal. $640 : 32 \cdot 56 : 28$ an'latpani'n' ma'nisin tabi'n'.

Sheshiliwi. An'latpada qawsi'rma joq ha'm wonda tek II basqi'sh a'melleri qatnasi'p ati'r. Demek, 1-qag'i'ya boyi'nsha, a'meller shepten won'g'a jazi'li'w ta'rtibinde izbe-iz wori'nlanadi'. A'mellerdi wori'nlaw ta'rtip cifri' a'meller u'stine jazi'lg'an:

$$\begin{array}{ccccccc} \textcircled{1} & \textcircled{2} & \textcircled{3} & & \textcircled{2} & \textcircled{3} & & \textcircled{3} \\ 640 : 32 \cdot 56 : 28 = & \underline{20} \cdot 56 : 28 = & \underline{1120} : 28 = & 40. \end{array}$$

Juwabi': An'latpani'n' ma'nisi 40 qa ten'.

2- qag'i'ya. Yeger an'latpada qawsi'rmalar bolmastan, ha'r yeki basqi'sh a'melleri de qatnassa, aldi'n II basqi'sh a'melleri, son' I basqi'sh a'melleri wori'nlanadi'.

3- mi'sal. $239 - 24 : 8 + 32 \cdot 7$ an'latpani'n' ma'nisin tabi'n'..

Sheshiliwi. An'latpada qawsi'rma joq ha'm wonda ha'r yeki basqi'sh a'melleri qatnasi'pati'r. Demek, 2-qag'i'ya boyi'nsha aldi'n II basqi'sh a'melleri, son' I basqi'sh a'melleri wori'nlanadi'. A'mellerdi wori'nlaw ta'rtip cifri' a'meller u'stine jazi'lg'an:

$$\begin{array}{ccccccc} \textcircled{3} & \textcircled{1} & \textcircled{4} & \textcircled{2} & & \textcircled{3} & \textcircled{4} & & \textcircled{4} \\ 239 - 24 : 8 + 32 \cdot 7 = & \underline{239} - 3 + 224 = & \underline{236} + 224 = & 460. \end{array}$$

Juwabi': An'latpani'n' ma'nisi 460 qa ten'.

3- qag'i'ya. Yeger an'latpada qawsi'rmalar qatnasqan bolsa, aldi'n qawsi'rmalar ishindegi a'meller, son' basqa a'meller 1- ha'm 2-qag'i'ydalar boyi'nsha wori'nlanadi'.

4- misol. $(1216 + 16 \cdot 9) : 4 - 1440 : 12$ an'latpani'n' ma'nisin tabi'n'.

Sheshiliwi. An'latpada qawsi'rmalar qatnasgan. Demek, 3-jag'dayda da aldi'n qawsi'rma ishindegi a'mellerdi wori'nlaymi'z. Son', 2-qag'i'ya boyi'nsha yesaplawlardi' dawam yettirez. A'mellerdi wori'nlaw ta'rtip nomeri a'meller u'stine jazi'lg'an:

$$\begin{aligned} & \overset{\textcircled{2}}{(1216 + 16 \cdot 9)} : 4 - 1440 : 12 = \overset{\textcircled{2}}{(1216 + 144)} : 4 - 1440 : 12 = \\ & = \overset{\textcircled{3}}{1360} : 4 - \overset{\textcircled{4}}{1440} : 12 = \overset{\textcircled{5}}{340} - 120 = 220. \end{aligned}$$

Juwabi': An'latpani'n' ma'nisi 220 g'a ten'.

17.2. Qawsi'rmalardi' ali'p taslaw

Yeger an'latpalardag'i' qawsi'rmalardi' ali'p taslaw a'mellerdin' wori'nlani'w ta'rtibine ta'sir yetpese, an'latpalardag'i' qawsi'rmalardi' ali'p taslaw mu'mkin. Ma'selen, $(49 + 23) - 39$ an'latpadag'i' qawsi'rmalardi' ali'p taslaw, $49 + 23 - 39$ ko'riniside jazi'w mu'mkin, sebebi bul a'mellerdi wori'nlaw ta'rtibine ta'sir qi'lmaydi'.

An'latpalardi'n' ma'nisin yesaplag'anda qosi'w, ali'w ha'm ko'beytiw a'mellerinin' qa'siyetlerinen paydalani'w maqsetke muwapi'q bolsa, a'mellerdi wori'nlaw ta'rtibi qag'i'ydalari'nan shetke shi'g'i'w da mu'mkin.

Ma'selen, $37 \cdot 8 + 13 \cdot 8$ an'latpani'n' ma'nisin 2-qag'i'ydag'a tiykarlani'p yesaplag'annan ko're, ko'beytiwdin' qosi'wg'a qarata bo'listiriw ni'zami'nan paydalani'p yesaplag'an qolayli': $37 \cdot 8 + 13 \cdot 8 = (37 + 13) \cdot 8 = 50 \cdot 8 = 400$.



Sorawlarg'a juwap berin'!

1. I ha'm II basqi'sh a'mellerin ayti'n'.
2. Tek bir basqi'sh a'melleri qatnasgan, qawsi'rmasi'z an'latpada a'meller qanday ta'rtipte wori'nlanadi'?
3. Ha'r yeki basqi'sh a'melleri qatnasgan, qawsi'rmasi'z an'latpada a'meller qanday ta'rtipte wori'nlanadi'?
4. Qawsi'rma qatnasgan an'latpada aldi'n qaysi' a'meller wori'nlanadi'?



Klasta wori'nlanatug'i'n shi'ni'g'i'wlar

381. An'latpada a'mellerdi wori'nlaw ta'rtibin ani'qlan' ha'm woni'n' ma'nisin tabi'n':

- | | |
|--|---|
| a) $78 - 45 + 54 - 49$; | b) $231 + 112 - 223 - 109$; |
| d) $721 : 7 - 112 : 8 + 37 \cdot 22$; | e) $322 : 23 \cdot 22 - 483 \cdot 9 : 23$; |
| f) $315 : (375 - 24 \cdot 15) + 98$; | g) $(24 \cdot 7 - 676 : 13) \cdot 13 - 238$. |

U'lg'i: Joqari'da ko'rilgen 1-, 2-, 3-, 4-mi'sallar.

382. Yesaplan':

- a) $(56 - 56) : 342 + (289 - 288) \cdot 122$; b) $(56 + 46) \cdot 23 + (444 - 443) \cdot 34$.

383. An'latpani'n' ma'nisin tabi'n':

a) $132 + 129 - 237 + 97$;

d) $945 : 45 \cdot 22 \cdot 12$;

f) $23 \cdot 12 + 490 : 14 - 224 : 16$;

h) $831 + 5865 : (22 \cdot 29 - 13 \cdot 19) - 87$;

b) $764 - 348 - 112 + 231$;

e) $24 \cdot 12 \cdot 25 : 100$;

g) $321 \cdot 12 : 69 + 644 : 23 - 93$;

i) $(3915 : 87 + 867) - (18 \cdot 15 - 1305 : 29)$.



384. Qosi'w ha'm ali'widi'n' qa'siyetlerine tiykarlang'an halda an'latpani'n' ma'nisin qolayli' usi'lda yesaplan':

a) $1278 + 432 + 568$;

b) $123 \cdot 4 \cdot 25$;

d) $2132 + 231 - 132$;

e) $32 \cdot 17 + 68 \cdot 17$;

f) $708 - 342 - 208$;

g) $786 \cdot 115 - 86 \cdot 115$.

385. $37 + 5 \cdot 7 - 3$ an'latpag'a qawsir'malardi' imkani' bar barli'q jag'daylarda qoyi'n' ha'm payda bolg'an ha'r bir an'latpani'n' ma'nisin tabi'n'.

386. An'latpa du'zin' ha'm woni'n' ma'nisin tabi'n':

a) $24 \cdot 11$ ko'beyme ha'm $96 : 3$ tiyindinin' qosi' ndi'si';

b) 510 sani'nan $236 + 128$ qosi'ndi'si'ni'n' ayi'r masi';

d) $27 + 3$ qosi'ndi'si'ni'n' $52 - 22$ ayi'rmag'a ko 'beymesi;

e) $31 + 29$ qosi'ndi'si'ni'n' 30 sani'na tiyindisi.



387. Yesaplan':

a) $97 + 13 662 : 27 + 36 944 - 43 \cdot 809$;

b) $988 + 1530 : (12 \cdot 6 - 38) \cdot 15$;

d) $4080 - (35 2719 - 57 837) : 98 + 307 \cdot 107$;

e) $40 \cdot (207 \cdot 54 - 793) - 270 000 : 18$;

f) $215 \cdot (368 - 274) + 68 \cdot (127 + 128)$;

g) $(8222 - 4781) : 37 - (1519 - 637) : 42$.

388. A'mellerdi wori'nlan':

a) $703 - 21 \cdot (361 - 349)$;

b) $23 460 : (209 - 186) \cdot 15$;

d) $6422 - 24 \cdot (372 : 12)$;

e) $2678 : (506 - 480) + 297$;

f) $77 \cdot (452 - 348) - 99$;

g) $874 - (27 \cdot 90 - 1999)$;

h) $(1593 : 27 + 326) \cdot 60$;

i) $6720 : 12 \cdot 35 - 898$.

389. An'latpani'n' ma'nisin tabi'n':

a) $(410 + 96) \cdot (1010 - 31 248 : 62) - 170 \cdot 1500$;

b) $(174 208 - 208 \cdot (563 + 44)) : 333 + 2079 : 77$;

d) $(18 \cdot 331 - (46 348 + 67 892) : 21) : 14 + 143 \cdot 26$;

e) $(201 \cdot (400 100 - 397 964) + 5392) : 24 - 8154$;

f) $(7470 : 18 - 319) + (2060 - 24 \cdot 45) : 28$.



390. An'latpani' a'piwayi'lasti'ri'n':

a) $2a + 612 + 7a + 324$;

b) $12y + 29y + 781 + 219$;

391. Avtomobil 240 km joldi' 4 saatta basi'p wo'tiwi kerek yedi. Biraq avtomobil tezligi 20 km/saat qa asi'ri'ldi'. Avtomobil ma'nzilge qansha waqi't aldi'n jetip keledi?

- 392.** Ali, Sali ha'm Vali ta'reziden wo'z salmaqlari'n wo'lshedi. Ma'lim boli'wi'nsha, Ali menen Salinin' awi'rli'g'i' birgelikte 55 kg, Sali menen Valinin' awi'rli'g'i' 58 kg ha'm Va'linin' awi'rli'g'i' 59 kg yeken. Ha'r bir balani'n' awi'rli'g'i' qansha yekenligin tabi'n'.



U'yde wori'nlanatug'i'n ma'seleler

- 393.** An'latpada a'mellerdi wori'nlaw ta'rtibin ani'qlan', son' woni'n' ma'nisin tabi'n':
 a) $123 - 67 + 231 - 224$; b) $445 + 333 - 369 - 206$;
 d) $824 : (399 - 23 \cdot 17) + 98$; e) $(52 \cdot 9 - 1035 : 45) \cdot 7 - 122$.
- 394.** An'latpani'n' ma'nisin tabi'n':
 a) $77 - 45 + 37 - 23$;
 b) $456 + 123 - 239 - 33$;
 d) $(31 \cdot 9 - 754 : 29) \cdot (1323 : 27 - 31)$;
 e) $(186 + 59 \cdot 6) : (19 \cdot 35 - 17 \cdot 37) - 12$.
- 395.** Qosi'w ha'm ali'w qa'siyetlerine tiykarlang'an halda a'mellerdin' wori'nlani'w ta'rtibin wo'zgartirin' ha'm qolayli' usi'lda an'latpani'n' ma'nisin yesaplan':
 a) $56 + 88 + 44$; b) $224 \cdot 4 \cdot 250$; d) $13245 + 8899 - 3245$;
 e) $87 \cdot 33 + 13 \cdot 33$; f) $1555 - 234 - 766$; g) $1199 \cdot 678 - 199 \cdot 678$.



- 396.** An'latpani' a'piwayi'lasti'ri'n':
 a) $11a + 43 + 76a + 27$; b) $332y + 211y + 999 + 677$;
 d) $234 + 35a + 725 + 16a$; e) $781 - 455 + 37n + 39n$.
- 397.** An'latpani'n' ma'nisin tabi'n':
 a) $66 \cdot 24 : 22 + 17017 : 17$; b) $(42 \cdot 25 - 36) : 39 + (800 : 40 - 18) \cdot 12$.
 d) $9 \cdot (1030 - 579) + 941$; e) $8000 - (398 + 132) \cdot 15$;
 f) $(770 - 669) \cdot (546 - 489)$; g) $136 \cdot (668 - 588) - 404 \cdot 25$;
 h) $1540 : 11 + 1890 : 9 + 982$; i) $1953 + (17432 - 56 \cdot 223) : 16$.
- 398.** Ten'lemeni sheshin':
 a) $3x + 5x + 96 = 1568$; b) $2y + 7y + 78 = 1581$;
 d) $88880 : 110 + x = 809$; e) $357y - 149y - 1843 = 11469$;
 f) $256m - 147m - 1871 = 63747$; g) $6871 + p : 121 = 7000$.



- 399.** Velosipedshiler birinshi ku'ni 154 km, yekinchi ku'ni birinshi ku'nnden 23 km ko'p, ushinshi ku'n bolsa yekinchi ku'nnden 13 km kem arali'qti' basi'p wo'tti. Velosipedshiler u'sh ku'nde qansha arali'qti' basi'p wo'tken?
- 400.** Tigiw cexi'nda ha'r biri 30 m den bolgan 9 top ha'm ha'r biri 40 m den bolgan 13 top gezleme bar yedi. Bul gezlemenin' 243 metri isletildi. Cexda neshe metr gezleme qaldi'?
- 401.** Sayxatshi' bir qaladan yekinshisine barmaqshi'. Wol aldi'n avtomobilde 70 km/saat tezlik penen 2 saat joldi basi'p o'tti. Son' piyada 4 saat 5 km/saat tezlik penen ju'rdu. Sonda yekinshi qalag'a shekem ja'ne 14 km jol qaldi'. Bul qalalar arasi'ndag'i' arali'q qansha?

18- §.

SANNI'N' DA'REJESI. SANNI'N' KVADRATI' HA'M KUBI'

Bir-birine ten' ko'beytiwshiler ko'beymesini arnawli' belgilew arqali' qi'sqasha jazi'ladi', yag'ni'y $3 \cdot 3 \cdot 3 \cdot 3 \cdot 3$ worni'na 3^5 tu'rinde jazi'ladi' ha'm «3 tin' 5 – da'rejesi» dep woqi'ladi'.

Bul jazi'wda 3 – *da'reje tiykari'*, 5 – *da'reje ko'rsetkishi*. 3^5 an'latpasi'ni'n' wo'zi bolsa *da'reje* dep ataladi.

To'mendegi ko'beymeni da'reje ko'riniside jazi'n' ha'm wolardi'n' ma'nisin tabi'n':

a) $2 \cdot 2 \cdot 2 \cdot 2 = 2^4 = 16$; b) $5 \cdot 5 \cdot 5 = 5^3 = 125$; c) $3 \cdot 3 \cdot 3 \cdot 3 \cdot 3 = 3^5 = 243$.

Sanni'n' yekinshi ha'm u'shinshi da'rejesi arnawli' atama menen ataladi'.

$3 \cdot 3$ ko'beyme 3 tin' *kvadrati'* delinedi ha'm 3^2 tu'rinde jazi'ladi'.

$4 \cdot 4 \cdot 4$ ko'beyme 4 tin' *kubi'* dep ataladi' ha'm 4^3 tu'rinde jazi'ladi'.

a ni'n' a g'a ko'beymesini *a sani'ni'n' kvadrati'* dep ataladi' ha'm a^2 ko'riniside jazi'ladi'.

Demek, $a^2 = a \cdot a$.

a^2 jazi'wi' «*a ni'n' kvadrati'*» yaki «*a kvadrat*» dep woqi'ladi.

Ma'selen, $12^2 = 12 \cdot 12 = 144$.

$a \cdot a \cdot a$ ko'beymesini *a sani'ni'n' kubi'* dep ataladi' ha'm a^3 ko'riniside jazi'ladi'.

Demek, $a^3 = a \cdot a \cdot a$.

a^3 jazi'wi' «*a ni'n' kubi'*» yaki «*a kub*» dep woqi'ladi'.

Ma'selen, $6^3 = 6 \cdot 6 \cdot 6 = 216$.

1 den 10 g'a shekem bolg'an natural sanlar kvadrati'ni'n' kestesini:

n	1	2	3	4	5	6	7	8	9	10
n^2	1	4	9	16	25	36	49	64	81	100

1 den 10 g'a shekem bolg'an natural sanlar kubi'ni'n' kestesini:

n	1	2	3	4	5	6	7	8	9	10
n^3	1	8	27	64	125	216	343	512	729	1000

Sanni'n' birinshi da'rejesi sol sanni'n' wo'zine ten' dep ali'nadi': $8^1 = 8, 13^1 = 13, 1^1 = 1$. A'dette, 1-da'reje ko'rsetkishi jazi'lmaydi'.

Yeger an'latpada da'rejeler de qatnasqan bolsa, aldi'n da'reje ma'nisleri jazi'ladi'. Son' basqa a'mellerdi wori'nlawg'a kirisiledi.

1- mi'sal. $(6^3 + 13) \cdot 2 - 2^4 \cdot 3^2$ an'latpasi'ni'n' ma'nisin tabi'n'.

Sheshiliwi. A'meller to'mendegi ta'rtipte wori'nlanadi':

$$\textcircled{1} \textcircled{4} \quad \textcircled{5} \quad \textcircled{7} \textcircled{2} \textcircled{6} \textcircled{3}$$

$$(6^3 + 13) \cdot 2 - 2^4 \cdot 3^2$$

Aldi'n da'rejeni yesaplaymi'z: $6^3 = 216, 2^4 = 16, 3^2 = 9$.

Wolardi' an'latpag'a qoyami'z ha'm yesaplawlardi' dawam yettirez:

$$(216 + 13) \cdot 2 - 16 \cdot 9 = 229 \cdot 2 - 16 \cdot 9 = 458 - 144 = 314.$$

Juwabi'. An'latpani'n' ma'nisi 314 g'a ten'.



Sorawlarg'a juwap berin'!

1. Sanni'n' a) kvadrati'; b) kubi' dep ne ayti'ladi'?
2. Da'reje, da'reje ko'rsetkishi, da'reje tiykari' atamalarin' qandayda bir mi'sal menen tu'sindirir'.
3. Natural sanni'n' birinshi da'rejesi nege ten' boladi'?



Klasta wori'nlanatug'i'n shi'ni'g'i'wlar

402. Da'reje tu'rinde jazi'n':

- a) $8 \cdot 8 \cdot 8 \cdot 8 \cdot 8 \cdot 8 \cdot 8$; b) $24 \cdot 24 \cdot 24 \cdot 24$; d) $x \cdot x \cdot x \cdot x \cdot x \cdot x$;
 e) $5 \cdot 5 \cdot 5 \cdot 5 \cdot 5$ f) $13 \cdot 13 \cdot 13 \cdot 13$; g) $m \cdot m \cdot m \cdot m$.
 h) $(x + 3) \cdot (x + 3) \cdot (x + 3) \cdot (x + 3)$; i) $(6 - z) \cdot (6 - z) \cdot (6 - z)$.

403. Yesaplan': 2^2 ; 5^2 ; 1^5 ; 7^2 ; 6^2 ; 1^6 ; 2^4 ; 4^3 ; 10^3 .

404. Yesaplan':

- a) $3^2 \cdot 11$; b) $5 + 6^2$; d) $(3 + 5)^2$; e) $(7^3 - 3^3) : (7 - 3)$;
 f) $(7 + 1)^3$; g) $(8 - 5)^3 : (8 - 5)$; h) $6^3 - 16$; i) $(9^2 - 2^6) : 17 + 4^2$.

405. To'mendegi an'latpalardi'n' ma'nisi ten'be?

- a) 6^2 ha'm $6 \cdot 2$; b) 3^4 ha'm $3 \cdot 4$; d) 3^2 ha'm 2^3 ; e) 5^3 ha'm 3^5 .

406. Ten'lemenin' korenin tabi'n':

- a) $x \cdot x = 36$; b) $p \cdot p = 81$; d) $y \cdot y \cdot y = 64$;
 e) $z \cdot z \cdot z \cdot z \cdot z = 1$; f) $m \cdot m \cdot m = 8$; g) $n \cdot n \cdot n \cdot n = 81$.

U'igi: a) $x \cdot x = 36$, $x \cdot x = 6 \cdot 6$, $x = 6$.

407. Da'rejenin' ma'nisin tabi'n': a) 5^2 ; b) 10^2 ; d) 100^3 ; e) 11^3 ; f) 12^3 ; g) 15^3 .

408. 11 den 20 g'a shekemgi bolg'an sanlardi'n' kvadratlari'ni'n' kestesin du'zin'.

409. An'latpani'n' ma'nisin tabi'n':

- a) 4^2 ; b) $23 + 3^2$; d) $(10^2 - 2^6) : 6 + 1^{10}$; e) $3^2 + 6^2$;
 f) $6^3 - 5^3$; g) $5^2 \cdot 2^3$; h) $(40 : 4)^5 - 100^2$; i) $(3 + 4)^2$.



410. Sanni'n' kvadrati' ha'm kubi' kestelerinen paydalani'p, n ni'n' ma'nisin tabi'n':
 a) $n^2 = 169$; b) $n^2 = 10000$; d) $n^3 = 729$; e) $n^3 = 343$.

411. Sandi' 10 ni'n' da'rejeleri ko'riniside jazi'n': 10, 100; 1000; 1 000 000;
 10 000 000.

412. 10 ni'n' da'rejelerinen paydalani'p, sandi' tan'ba birliklerinin' qosi'ndi'si'
 tu'rinde jazi'n':

- a) 432; b) 328; d) 3451; e) 20 450; f) 213 709.

U'igi: a) $432 = 400 + 30 + 2 = 4 \cdot 100 + 3 \cdot 10 + 2 \cdot 1 = 4 \cdot 10^2 + 3 \cdot 10^1 + 2 \cdot 1$.

413. Yesaplan':

- a) $2 \cdot 10^3$; b) $(2 \cdot 10)^3$; d) $3 \cdot 2^2$; e) $(3 \cdot 2)^2$; f) $12 : 2^2$; g) $(12 : 2)^2$.

414. Ten'likti tekserip ko'rin':

- a) $2^3 + 2^5 + 2^6 + 2^7 + 2^8 + 2^9 = 1000$; b) $11^3 + 12^3 + 13^3 + 14^3 = 8000$;
d) $41^2 + 43^2 + 45^2 = 5555$.

415. An'latpani'n' ma'nisin tabi'n':

- a) $15^2 + 2^3 \cdot 11$; f) $9^3 : (49 - 22)$;
b) $125 + 5^3 \cdot 3$; g) $2^5 \cdot (12 + 2^3)^2$;
d) $4^3 \cdot 13 + 3^4 \cdot 12$; h) $(13 \cdot 11 - 43)^3$;
e) $1500 : 5^3 + 693 : 3^2$; i) $(13 - 4 \cdot 2)^3 : (2^2 + 1)^2$.

416. To'mendegi sanni'n' kvadrati' qanday san menen tamamlanadi'?

- a) 122; b) 923; d) 225; e) 211.

U'yde wori'nlanatug'i'n ma'seleler



417. Da'reje ko'riniside jazi'n':

- a) $3 \cdot 3 \cdot 3 \cdot 3 \cdot 3 \cdot 3$; b) $32 \cdot 32 \cdot 32 \cdot 32 \cdot 32 \cdot 32 \cdot 32$;
d) $d \cdot d \cdot d \cdot d \cdot d \cdot d$; e) $(x + y) \cdot (x + y) \cdot (x + y) \cdot (x + y)$.

418. Yesaplan':

- a) $4^2 \cdot 33$; b) $7 + 5^2$; d) $(4+3)^3$; e) $7^2 + 5^2$;
f) $(5 + 7)^2$; g) $(9 - 6)^4$; h) $(40 : 8)^3 + 24$; i) $(9^2 - 5^2) \cdot 5 - 35$.

419. Da'rejenin' ma'nisin tabi'n': a) 7^2 ; b) 11^2 ; d) 10^3 ; e) 16^3 ; f) 13^3 ; g) 19^3 .

420. Yesaplan':

- a) $5 \cdot 6^3$; b) $(3 \cdot 10)^2$; d) $4 \cdot 5^2$; e) $(4 \cdot 5)^2$; f) $3 \cdot 9 : 3^2$; g) $(39 : 3)^2$.



421. An'latpani'n' ma'nisin tabi'n':

- a) $8^2 \cdot 6 + 15^2 : 5$; b) $(16 - 7)^3 - 4^2$; d) $5 \cdot 3^3 - 16^2 : 8$;
e) $(3 \cdot 2)^3 - (36 : 9)^2$; f) $(4 \cdot 6^2 : 2^3 + 16) \cdot 5$; g) $(7^3 + 11^2 \cdot 5) - 512$.

422. To'mendegi sanni'n' kubi' qanday san menen tamamlanadi'?

- a) 544; b) 1111; d) 5222; e) 77 777.

423. Yesaplan'.

- a) $3 \cdot 10^4 + 2 \cdot 10^3 + 7 \cdot 10^2 + 9 \cdot 10 + 4$;
b) $6 \cdot 10^5 + 1 \cdot 10^3 + 9 \cdot 10^2 + 5$.

Qizig'arli' matematikag'a tiyisli ma'seleler



Sanli' krossvordti' sheshin':

- Tigine: a) 564 676 : 938;
f) 527 809 + 36 895;
j) 460 015 - 36296;
h) 411 510 : 473.

- Kesesine: a) 7 003 294 - 435 926;
b) 40 320 : 672;
d) 357 992 : 4 904;
e) 590 \cdot 5 047.

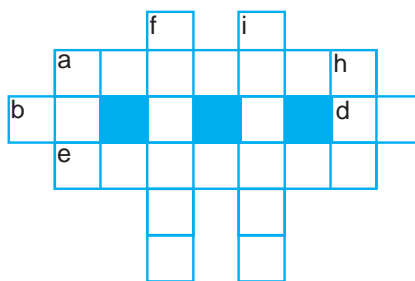

19- §.

III BAPTI' TA'KIRARLAWG'A TIYISLI MA'SELELER SHESHIW

19.1. Ha'reketg'e tiyisli ma'selelerdi sheshiw.

Aldi'ng'i' sabaqlarda ha'reketke tiyisli tu'rli ma'selelerge dus keldik. Bul ma'selelerde a'dette bir-biri menen baylani'ni'sli' u'sh shama: *tezlik*, yag'ni'y waqi't birligi ishinde basi'p wo'tken jol, *ha'reket waqti'* ha'm *basi'p wo'tilgen jol* qatnasadi'.

1-mi'sal. A punktten birdey waqi'tta qarama-qarsi' bag'i'tta yeki jolawshi' jolg'a shi'qti'. Birinshi jolawshi'ni'n' tezligi 6 km/saat, yekinshisiniki 4 km/saat. 2 saattan keyin jolawshi'lar arasi'ndag'i' arali'q qansha boladi'?

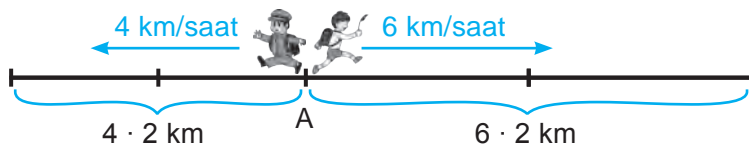

Sheshiliwi. 1-usi'l. 2 saatt dawami'nda ha'r bir jolawshi' basi'p wo'tken joldi' tabami'z:

1- jolawshi': $6 \cdot 2 = 12$ (km). 2- jolawshi': $4 \cdot 2 = 8$ (km).

Demek, 2 saattan keyin wolar arasi'ndag'i' arali'q $12 + 8 = 20$ (km) ge ten' boladi'.

2-usi'l. Bir saattan keyin jolawshi'lar arasi'ndag'i' arali'q $4 + 6 = 10$ (km) ge ten' boladi'. Bul jag'dayda, jolawshi'lardi'n' bir-birinen *uzaqlasi'w tezligi* 10 km/saatqa ten' boladi'.

Demek, jolawshi'lar 2 saattan keyin bir-birinen $2 \cdot 10 = 20$ (km) uzaqli'qta boladi' (km).

Juwabi': 20 km.

2-mi'sal. Yeki jolawshi' birdey waqi'tta yeki punktten bir-birine qarap jolg'a shi'qti'. Yeki punkt arasi'ndag'i' arali'q 27 km. Birinshi jolawshi'ni'n' tezligi 5 km/saat, yekinshisiniki bolsa 4 km/saat. Jolawshi'lar qansha waqi'ttan keyin bir-biri menen ushi'rasadi'?



Sheshiliwi. Jolawshi'lardi'n' bir-birine *jaqi'nlas'i'w tezligin* tabami'z: $5 + 4 = 9$ (km/saat). Jolawshi'lar arasi'ndag'i' arali'q 27 km boli'p, wolar 1 saatta bir-birine m ge jaqi'nlasadi'.

Demek, jolawshi'lar $27 : 9 = 3$ (saat) tan keyin ushi'rasadi'.

Juwabi': 3 saat.

19.2. Da'ryada ha'reketleniwge tiyisli ma'selelerdi sheshiw

Da'rya boyi'nsha ha'reketke tiyisli ma'selelerde *da'rya ag'i'mi' boyi'nsha* ha'reket tezligin, *da'rya ag'i'mi'na qarsi'* ha'reket tezliginen pari'qlay ali'wi' kerek boladi'.

Aytayi'q, qayi'qti'n' wo'z tezligi, yag'ni'y woni'n' turg'i'n (aqpaytug'i'n) suwdag'i' tezligi – 8 km/saat, da'rya ag'i'mi'ni'n' tezligi bolsa 2 km/saat bolsi'n.

Wonda qayi'qti'n' da'rya ag'i'mi' boyi'nsha ha'reketleniw tezligi – woni'n'

wo'z tezligi ha'm da'rya ag'i'mi' tezliklari qosi'ndi'si'nan ibarat boladi':
 $8 + 2 = 10$ (km/saat).

$$U_{ag'i'm\ boyi'nsha} = U_{qayi'q} + U_{ag'i'm}$$

Qayi'qti'n' da'rya ag'i'mi'na qarsi' ha'reket tezligi - woni'n' wo'z tezligi ha'm da'rya ag'i'mi' tezligi ayi'rmasi'nan ibarat: $8 - 2 = 6$ (km/saat).

$$U_{ag'i'mg'a\ qarsi'} = U_{qayi'q} - U_{ag'i'm}$$

3-mi'sal. Kater da'rya ag'i'mi' boyi'nsha ju'zbekte. Da'rya ag'i'mi'ni'n' tezligi 3 km/saat. Yeger katerdin' wo'z tezligi 18 km/saat bolsa, wol 2 saatta qansha arali'qti' basi'p wo'tedi?

Sheshiliwi. Kater ag'i'm boyi'nsha ju'zgeni ushi'n woni'n' ha'reket tezligi woni'n' wo'z tezligi ha'm da'rya ag'i'mi' tezliginin' qosi'ndi'si'nan ibarat boladi': $18 + 3 = 21$ (km/saat). Kater bul tezlik penen 2 saatta: $21 \cdot 2 = 42$ (km) arali'qti' basi'p wo'tedi.

Juwabi': 42 km.

19.3. U'shinshi bapqa tiyisli ma'selelerdi sheshiw

424. An'latpani'n' ma'nisin tabi'n':

- a) $210 + 210 + 210 + 210 + 4571$; b) $88 + 88 + 88 + 333 + 333 + 333$;
 d) $523 + 523 + 3278 + 523 + 3278$; e) $6530 + 153 + 153 + 6530 + 153 + 153$.

425. Gruppalaw ni'zami'nan paydalani'p, ko'beymeni yesaplan'.

- a) $25 \cdot (4 \cdot 7709)$; b) $(200 \cdot 13) \cdot 5$; d) $8 \cdot (125 \cdot 333)$; e) $(1010 \cdot 4) \cdot 25$.

426. Qolayli' usi'l menen yesaplan'.

- a) $40 \cdot 331 \cdot 25$; b) $424 \cdot 25 \cdot 4$; d) $8 \cdot 550 \cdot 125$; e) $50 \cdot 539 \cdot 20$.

427. Yeger $a = 21$, $b = 36$ bolsa, $55a - 3b$ an'latpasi'ni'n' ma'nisin tabi'n'.

428. Jip uzi'nli'g'i' 14 dm den bolg'an 13 bo'lekke bo'lingen. Jiptin' uzi'nli'g'i'n tabi'n'.

429. ABC u'shmu'yeshliktin' AB ta'repi 234 mm ha'm wol AC ta'repinen 5 ma'rte qi'sqa. Yeger u'shmu'yeshliktin' perimetri 2450 mm bolsa, BC ta'repinin' uzi'nli'g'i'n tabi'n'.

430. A'mellerdi wori'nlan':

- a) $24 \cdot 52 - 18 \cdot (117 - 97)$; b) $(2574 + 4333) \cdot 25 - 110 \cdot 14$.

431. Avstraliya materiginde jasaytug'i'n kenguru 12 m uzi'nli'qqa sekiriwi mu'mkin. Bul a'jayi'p haywan 100 ma'rte sekirse qansha arali'qti' basi'p wo'tedi? Wol 1500 metr arali'qti' neshe ma'rte sekirip basi'p wo'tiwi mu'mkin?

432. Kenguru saati'na 48 km tezlikte juwi'ri'wi' mu'mkin. a) Kenguru 1 saatta neshe metr juwi'ri'wi' mu'mkin? 1 minutta-ne? b) Wol 12 km arali'qti' qansha waqi'tta basi'p wo'tedi? d) Wol 30 sekundta qansha arali'qti' basi'p wo'tedi? 5 minutta-ne?

433. Yesaplan'. Na'tiyjeni ko'beytiw arqali' tekserin':

- a) $10\ 092 : 116$; b) $7728 : 138$; d) $9379 : 83$;
 e) $12\ 432 : 111$; f) $11\ 704 : 77$; g) $30\ 015 : 145$.

434. Zahid kompyuterde saati'na 987 belgi kirite aladi'. Wol 12 831 belgili tekstti qansha waqi'tta kirite aladi'?
435. A'mellerdi wori'nlan':
 a) $33 \cdot x = 1386$; b) $454 \cdot a = 55\ 842$; d) $x : 19 = 13$;
 e) $a : 119 = 314$; f) $26\ 289 : x = 127$; g) $42\ 745 : m = 415$.
436. Qaldi'qli' bo'liwdi wori'nlan':
 a) $983 : 18$; b) $3273 : 16$; d) $4213 : 34$;
 e) $5620 : 67$; f) $55\ 337 : 134$; g) $54\ 103 : 439$.
437. Sonday sandi' tabi'n', woni':
 a) 17 ga bo'lgende, 88 payda boli'p, 11 qaldi'q qalsi'n;
 b) 231 ga bo'lgende, 121 payda boli'p, 133 qaldi'q qalsi'n.
438. Uli'wma ko'beytiwshini qawsi'rma si'rti'na shi'g'ari'p yesaplan':
 a) $66 \cdot 112 + 34 \cdot 112$; b) $356 \cdot 97 - 56 \cdot 97$; d) $867 \cdot 74 + 867 \cdot 26$;
 e) $11 \cdot 54 + 89 \cdot 54$; f) $473 \cdot 164 - 473 \cdot 64$; g) $329 \cdot 251 - 129 \cdot 251$.
439. Yeki ku'nde 294 yashik ju'zim terildi. Yekinshi ku'ni birinshi ku'nge qarag'anda 6 ma'rte ko'p ju'zim terildi. Birinshi ku'ni qansha ju'zim terilgen?
440. Birinshi konveyerde 1 saatta 25, yekinshi konveyerde bolsa 31 televizor ji'ynaladi'. Yeki konveyerde 8 saat dawami'nda qansha televizor ji'ynaladi'?
441. An'latpadagi' a'mellerdi wori'nlaw ta'rtibin ani'qlan', son' ma'nisin tabi'n':
 a) $2448 + 666 - 1291 - 1067$; b) $26 \cdot 27 : 18 \cdot 22$;
 d) $2080 : (1222 - 26 \cdot 27) + 128$; e) $(25 \cdot 19 - 1800 : 75) \cdot 11 - 221$.
442. An'latpani' a'piwaylasti'ri'n':
 a) $109d + 443 + 273d + 279$; b) $332t + 211t + 999 + 677$;
 d) $34 + 139c + 257 + 61c$; e) $1786 - 903 + 430q + 453q$.
443. Ten'lemeni sheshin':
 a) $7x + 6x + 1000 = 1975$; b) $57y - 14y - 111 = 3200$;
 d) $20838 : 453 + x = 91$; e) $875 + p : 121 = 1999$;
 f) $381 + 126 : y = 395$; g) $k + 11\ 571 : 133 = 487$.
444. Su'wretten paydalani'p ten'leme du'zin' ha'm belgisiz ma'nisti tabi'n':

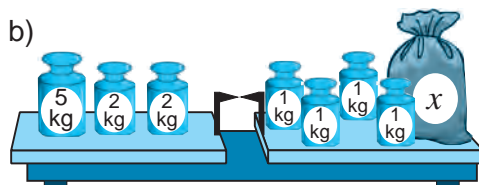
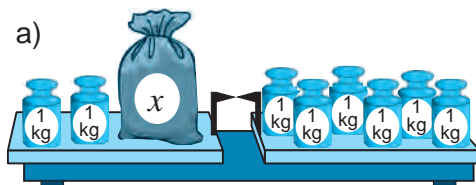

445. Yesaplan':
 a) $(129 - 116)^4$; b) $(11^2 - 8^2) \cdot 23 - 87$; d) $7^2 \cdot 52$; e) $(7+6)^3$;
 f) $44^2 + 33^2$; g) $(81:9)^3 + 111$; h) $(15+12)^2$; i) $8^2 + 13^2$.
446. An'latpani'n' ma'nisin tabi'n':
 a) $1562 - 16^2 : 8$; b) $(12 + 169 : 13)^2$; d) $(127 - 77)^2 \cdot 9$; e) $11^2 \cdot (114 - 98)$.
447. A'piwayi' lampani'n' xizmet mu'ddeti 1500 saat. Energiyani' u'nemlewshi lampa bolsa apiwayi' lampag'a qarag'anda 7 ma'rte uzag'i'raq waqi't xizmet qi'ladi'. Energiyani' tejewshi lampani'n' xizmet mu'ddetin tabi'n'.

Qi'ziqli' matematikag'a tiyisli ma'seleler



Sanli' krossvordtii sheshin':

- Tigine: a) $870 \cdot 706$;
 h) $100\ 000 - 43\ 535$;
 j) $1412 \cdot 435$.
- Kesesine: a) $12 \cdot 5303$; b) $820\ 820 : 9020$;
 d) $143\ 412 : 7548$; e) $148 \cdot 159$;
 f) $50\ 381 : 83$; g) $460\ 312 : 652$.

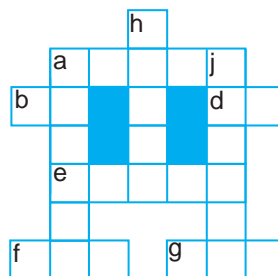

U'lken sanlar

Million ha'm milliard sanlari' menen tani'spi'z. Arnawli' at penen atali'wshi' wolardan da u'lken sanlar bar. Biraq, wolar ju'da' kem qollani'ladi'. Mine wolardi'n' bazi' birewleri menen tani'si'n':

$10^6 =$	1 000 000	million
$10^9 =$	1 000 000 000	milliard
$10^{12} =$	1 000 000 000 000	trillion
$10^{15} =$	1 000 000 000 000 000	kvadrillion
$10^{18} =$	1 000 000 000 000 000 000	kvintillion
$10^{21} =$	1 000 000 000 000 000 000 000	seksillion
$10^{24} =$	1 000 000 000 000 000 000 000 000	septillion
$10^{27} =$	1 000 000 000 000 000 000 000 000 000	oktallion

Bilimin'izdi si'nap ko'rin'!



Bul bapti'n' materillari'n u'yrenip shi'g'i'p, to'mendegi ma'selelerdi sheshe ali'wi'n'i'z sha'rt! Qadag'alaw jumi'si' aldi'nan wo'zin'izdi si'nap ko'rin'!

Test. Duri's juwapti' ani'qlan':

- Tiyindi bo'liwshige ko'beytilse ne payda boladi'?
 A. Bo'liniwshi; B. Ko'beyme; D. Ko'beyti wshi; E. Tiyindi.
- An'latpani'n' ma'nisin yesaplawda qosi'w a'meli neshinshi wori'nda wori'nlanadi' $(6^3 + 13) \cdot 2 - 11$?
 A. Birinshi; B. Yekinshi; D. U'shinshi; E. To'rtinshi.
- Ko'beytiwshiler worni' almasti'ri'lsa, ko'beyme haqqi'nda ne ayti'w mu'mkin?
 A. Wo'zgeredi; B. Ko'beyedi; D. Azayadi'; E. Wo'zgermeydi.

5-qadag'alaw jumi's u'lgisi

- An'latpani'n' ma'nisin tabi'n':
 a) $58 \cdot 196$; b) $4600 \cdot 1760$; d) $405 \cdot 208$; f) $36\ 490 : 178$; e) $17\ 835 : 145$.
- Ten'lemeni sheshin':
 a) $14 \cdot x = 112$; b) $133 : y = 19$; d) $t : 15 = 90$.
- Qolayli' usi'l menen yesaplan':
 a) $25 \cdot 197 \cdot 4$; b) $8 \cdot 567 \cdot 125$; d) $50 \cdot 23 \cdot 40$.
- Ma'seleni ten'leme du'zip sheshin': Kamil bir san woyladi'. Woni' 3 ke ko'beytip, ko'beymeden 7 ni aldi'. Na'tiyjede 50 payda boldi'. Ka'mil qanday san woylag'an?
- Ten'lemenin' sheshimin tabi'n': $x + x - 20 = x + 5$.



$$V = 10 \text{ dm}^3$$

IV BAP. MAYDAN HA'M KO'LEMLER

20- §.

FORMULALAR

Matematikada ko'p g'ana qag'i'yda formula menen an'latilg'an dep aytiladi'. Ushu waqitqa shekem qosiw ha'm ko'beytiw qag'i'ydalari'n *formulalar* menen an'latatug'in yedik.

1-mi'sal. Avtomobil 60 km/saat tezlik penen 4 saat ju'rdu. Avtomobil neshe km jol ju'rgen?

Sheshiliwi. Qag'i'yda boyinsha basi'p wo'tilgen joldi' tabi'w ushi'n tezlik ha'reket waqti'na ko'beytiledi:

$$\text{Basi'p wo'tilgen jol} = \text{Tezlik} \cdot \text{Waqi't}$$

Wog'an tiykarlansa, $60 \cdot 4 = 240$ yag'i'y avtomobil 240 km jol ju'rgen.

Yendi basi'p wo'tilgen joldi' tezlik ha'm waqi't boyinsha tabi'w formulasi'n jazayi'q. Buni'n ushi'n joldi' – S , tezlik – v , waqi'tti' – t ha'ripleri menen belgileymiz.

Wonda:

$$S = v \cdot t$$

Qandayda bir qag'i'ydani'n ha'ripler ja'rdeminde jazi'lg'an an'latpasi'na *formula* dep ataladi'.

Ma'selen, ta'repleri a ha'm b bolg'an tuwri' to'rtmu'yeshlik perimetri to'mendegi formula ja'rdeminde an'latiladi' (1- su'wret):

$$P = 2a + 2b$$

Ta'repi a bolg'an kvdratti'n perimetri bolsa to'mendegi formula ja'rdeminde an'latiladi' (2- su'wret):

$$P = 4a$$

Wolardi'n duri'sli'g'i'n wo'z betin'izshe tekserip ko'rin'.

$$\begin{array}{c}
 a \\
 \boxed{P = 2a + 2b} \\
 b \\
 \text{1- su'wret}
 \end{array}$$

$$\begin{array}{c}
 a \\
 \boxed{P = 4a} \\
 a \\
 \text{2- su'wret}
 \end{array}$$

Formularlar an'latpasi'nda wo'lshem birlikleri jazi'lmaydi'. Biraq, juwap jazi'lg'anda a'l'bette wo'lshem birliklerin yesten shi'g'armaw kerek.

2-mi'sal. Poezd 70 km/saat tezlik penen ha'reketlenbekte. Wol 350 km arali'qti' qansha saatta basi'p wo'tedi?

Sheshiliwi. $S = v \cdot t$ formuladag'i' ha'ripler worni'na ma'selede berilgen belgili ma'nislerdiqoyami'z. Na'tiyjede, $350 = 70 \cdot t$ ten'lemani paydayetemiz. Woni' sheship $t = 350 : 70$ yamasa $t = 5$ yekenligin tabami'z.

Demek, poezd 350 km arali'qti' 5 saatta basi'p wo'tedi.

Ma'selenin' sha'rti ha'm sheshimi da'pterge to'mendegishe jazi'ladi':

Berilgen:

$$v = 70 \text{ km/saat}$$

$$S = 350 \text{ km}$$

$$t = ?$$

Sheshiliwi:

$$S = v \cdot t,$$

$$350 = 70 \cdot t,$$

$$t = 5.$$

Juwap: 5 saatta.

Sorawlarg'a juwap berin'!



1. Formula dep nege ayti'ladi'? Mi'sallar keltirin'.
2. Basi'p wo'tilgen joldi' tabi'w formulasi'n jazi'n'. Wonda qatnasqan ha'ripler menen ne belgilenedi?
3. Basi'p wo'tilgen jol ha'm tezlik boyi'nsha waqi't qalay tabi'ladi'?
4. Basi'p wo'tilgen jol ha'm waqi't berilgen bolsa, tezlik qalay tabi'ladi'?

Klasta wori'nlanatug'i'n shi'ni'g'i'wlar



- 448.** $S = v \cdot t$ formula boyi'nsha:
- a) 986 km/min tezlik penen 34 minutta;
 - b) 15 km/saat tezlik penen 5 saatta basi'p wo'tilgen joldi' tabi'n'.
- 449.** Basi'p wo'tilgen joldi' tabi'w formulasi'nan paydalani'p, t – waqi'tti' tabi'n':
- a) $S = 72 \text{ km}$, $v = 12 \text{ km/saat}$; b) $S = 360 \text{ m}$, $v = 90 \text{ m/saat}$.
- 450.** Tuwri'mu'yeshliktin' a) ta'repleri $a = 8 \text{ dm}$, $b = 12 \text{ dm}$ bolsa, woni'n' perimetrin; b) perimetri 46 sm ha'm ta'replerinin' biri 12 sm bolsa yekinshi ta'repin tabi'n'.
- 451.** Kvadratti'n' a) ta'repi $a = 32 \text{ mm}$ bolsa, woni'n' perimetrin; b) perimetri 96 dm bolsa, woni'n' ta'repin tabi'n'.
- 452.** Motociklshi' 75 km/saat tezlik penen 4 saatta qansha jol basi'p wo'tedi?
- 453.** Sportshi' 200 m arali'qti' 25 s ta basi'p wo'tedi. Sportshi'ni'n' tezlighin tabi'n'. 
-
- 454.** Jer Quyash a'tirapi'nda 30 km/s tezlik penen aylanadi'. 1 saat dawami'nda Jer qansha arali'qti' basi'p wo'tedi? 1 minutta she?
- 455.** Tuwri'mu'yeshliktin' ta'repleri 18 dm ha'm 22 dm. Perimetri tuwri'mu'yeshliktin' perimetrine ten' bolg'an kvadratti'n' ta'repin tabi'n'.

456. $S = v \cdot t$ yamasa $P = 2a + 2b$ formuladan paydalani'p kesteni toltiri'n';

a)

S	3150 km	672 km	600 m	45 km
v		56 km/saat		5 m/s
t	7 soat		40 s	

b)

a	12 sm	8 dm	35 m
b	6 sm	6 dm	
P			220 m

457. 3- su'wrette keltirilgen ko'pmu'yeshliktin' ta'replerin si'zgi'sh ja'rdemide wo'lshen' ha'm woni'n' perimetrin tabi'n':



458. 4- su'wrette keltirilgen ko'pmu'yeshliktin' perimetrin berilgen mag'li'wmatlar tiykari'nda tabi'n':

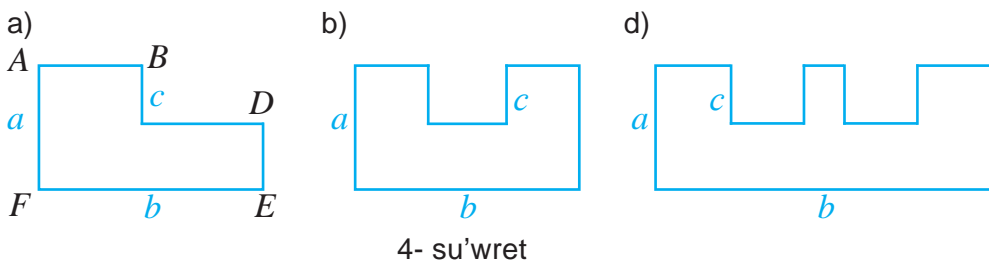

U'lgi: a) $AB + CD = b$ ha'm $BC + DE = a$ bolg'ani' ushi'n $P = 2a + 2b$.



U'yde wori'nlanatug'i'n ma'seleler

459. Basi'p wo'tilgen joldi' tabi'w formulasi'nan paydalani'p, v – tezliktin' ma'nisin tabi'n':

a) $S = 450$ km, $t = 90$ saat; b) $S = 280$ m, $t = 7$ s.

460. Tuwri'mu'yeshliktin' perimetrin tabi'w formulasi' tiykari'nda tuwri'mu'yeshliktin' a) ta'repleri $a = 230$ sm, $b = 12$ dm bolsa, woni'n' perimetrin; b) perimetri 320 m ha'm ta'replerinin' biri 122 m bolsa, yekinshi ta'repin tabi'n'.

461. Kvadratti'n' a) $a = 134$ dm bolsa, woni'n' perimetrin; b) perimetri 288 m bolsa, woni'n' ta'repin tabi'n'.



462. Piyada 70 m/min tezlik penen 25 minutta qansha jol basadi'?

463. Tez juwi'ri'w jari'si'nda sportshi' 10 km arali'qti' 5 m/s tezlik penen basi'p wo'tti. Sportshi' qansha waqi't juwi'rg'an?

464. Tuwri'mu'yeshliktin' bir ta'repi 24 sm, yekinshi ta'repi birinshisinen 3 ma'rte uzi'n. Tuwri'mu'yeshliktin' perimetrin tabi'n'.

21- §.

MAYDAN. TUWRI'MU'YESHLIK HA'M KVADRAT MAYDANI FORMULALARI

To'mendegi su'wrette su'wretlengen shokolad neshe kvadrat ko'rinishidagi bo'leklerden ibarat?



a)

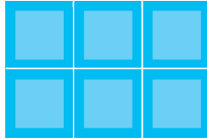

b)

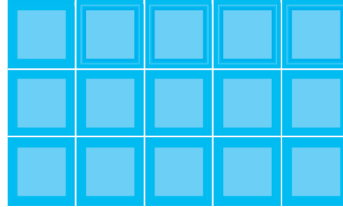

21.1. Maydan haqqi'nda tu'sinik

Ko'p g'ana a'meliy ma'selelerde qa'legen jer maydani', diywal, pol maydani'n wo'lshewge tuwra keledi. Bunday jag'dayda aldi'n maydan wo'lshe m birligin tan'law lazi'm. Maydan wo'lshe m birligi si'pati'nda ta'repi uzi'nli'q birligine ten' bolg'an kvadrat ali'nadi'. Ma'selen, yeger ta'repi 1 m ge ten' kvadrat ali'nsa, maydan wo'lshe m birligi 1 m² (1 kvadrat metr) boladi'. yeger ta'repi 1 sm ge ten' kvadrat ali'nsa, maydan wo'lshe m birligi 1 sm² (1kvadrat santimetr) boladi'.

Qa'legen figurani'n' maydani'n yesaplaw degende, woni'n' neshe birlik kvadrat penen qaplaw mu'mkinligin tabi'w tu'siniledi.



Ma'selen, 1- su'wrette su'wretlengen birinshi figura maydani' 1sm² qa ten' bolg'an 6 ta, yekinshi figura 8 kvadratlardan ibarat.

Demek, woni'n' maydani' 6 sm² ha'm 8 sm² qa ten' boladi'.

a)

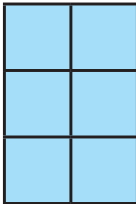

1- su'wret

b)

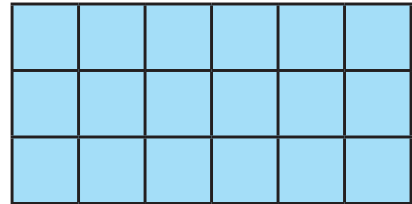
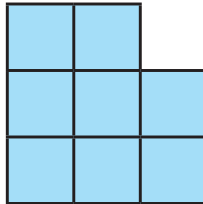

2- su'wret

21.2. Tuwri'mu'yeshlikin' maydani'

Yeni 3 sm, uzunligi 6 sm bolgan tuwri'mu'yeshlikti qaraytug'i'n bolsaq.

Tuwri'mu'yeshlik bolsa, $6 \cdot 3 = 18$ birlik kvadratlardan du'zilgen. Demek, tuwri'mu'yeshliktin' maydani' 18 sm² qa ten' (2- su'wret).

Yeger tuwri'mu'yeshliktin' maydani'n – S , uzi'nli'g'i'n – a , yenin bolsa – b ha'ripleri menen belgilesek,

$$S = ab$$

ko'rinishidagi tuwri'mu'yeshliktin' maydani'n yesaplaw formulasi'na iye bolami'z.

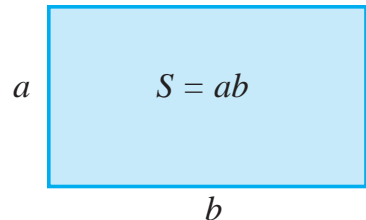



Tuwri'mu'yeshliktin' maydani'n tabiw ushin woni' uzi'nli'g'i'n yenine ko'beytuw kerek.

Bizge belgili, kvadrat ta'repleri ten' bolg'an tuwri'mu'yeshlik. 3-su'wrette su'wretlengen kvadratti'n' ta'repi 5 sm ge ten'. Wol $5 \cdot 5 = 25$ birlik kvadratlari'nan ibarat.

Demek, woni'n' maydani' 25 sm^2 qa ten'.

Kvadratti'n' ta'replerin a dep belgilesek, kvadratti'n' maydani'

$$S = a^2$$

formula menen an'lati'ladi'.

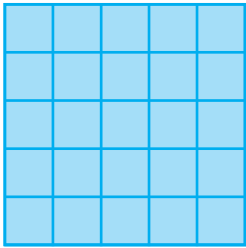
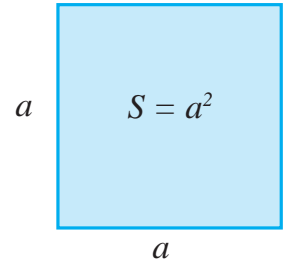

3- su'wret

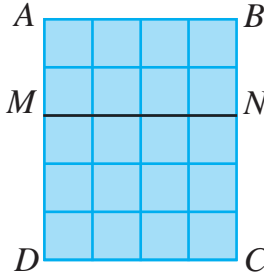

4- su'wret

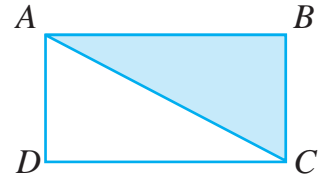

5- su'wret

Birinin' u'stine yekinhisi qoyilg'anda u'stpe-u'st tu'setug'i'n figuralar *ten' figuralar* dep ataladi'.



Ten' figuralardi'n' maydani' da ten' boladi'.

4-su'wrette maydani' 20 sm^2 qa ten' bolg'an $ABCD$ tuwri'mu'yeshlik su'wretlengen. Woni' MN kesindi yeki $ABNM$ ha'm $MNCD$ tuwri'mu'yeshlikke aji'ratadi'. Birinshi tuwri'mu'yeshliktin' maydani' 8 sm^2 qa, yekinhisiniki bolsa 12 sm^2 qa ten'.

Soni'n' menen birge $20 = 8 + 12$.

Demek, to'mendegi qa'siyetke iyemiz:



Figurani'n' maydani' woni' payda yetken bo'leklerdin' maydani'ni'n' qosi'ndi'si'na ten'.

5-su'wrette AC kesindisi $ABCD$ tuwri'mu'yeshlikti yeki ten' u'shmu'yeshlikke aji'ratadi'. Demek, ha'r bir u'shmu'yeshliktin' maydani' tuwri'mu'yeshliktin' maydani'ni'n' yari'mi'na ten'.



Sorawlarg'a juwap berin'.

1. Maydan wo'lshem birligi si'pati'nda ne ali'nadi'?
2. Figurani'n' maydani' degende ne tu'siniledi'?
3. Tuwri'mu'yeshliktin' maydani'n tabi'w formulasi'n jazi'n'.
4. Qanday figuralar ten' delinedi'?
5. Ten' figuralardi'n' maydani' haqqi'nda ne ayti'w mu'mkin'?
6. Bo'leklerdin' maydani'na qarap, pu'tin figurani'n' maydani' qalay tabi'ladi'?

Klasta wori'nlanatug'i'n shi'ni'g'i'wlar



465. Bir kishi kvadratti'n' maydani' 1 sm² qa ten' yekenligi belgili bolsa, 6-su'wrettegi figurani'n' maydani'n ayti'n'.

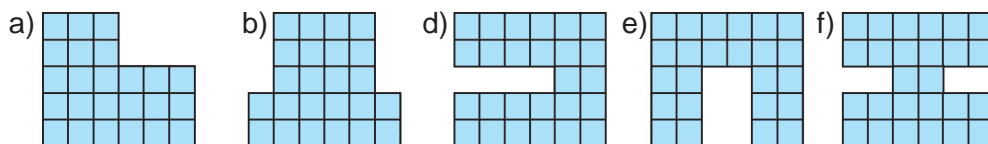

6- su'wret

466. Tuwri'mu'yeshliktin' maydani'n yesaplaw formulasi'nan paydalani'p, woni'n' maydani'n tabi'n'.

- a) $a = 5$ m, $b = 3$ m;
- b) $a = 4$ dm, $b = 360$ sm;
- d) $a = 12$ sm, $b = 43$ sm;
- e) $a = 12$ m, $b = 56$ dm.

Ko'rssetpe: Yesaplawdan aldi'n berilgenlerdi birdey wo'lshem birligine wo'tkerin'.

467. $S = a \cdot b$ formulasi' boyi'nsha kesteni tolti'ri'n':

a	16 sm	130 m		43 m	240 sm
b	14 sm	80 m	24 dm		12 dm
S			432 dm ²	2322 m ²	

468. Si'zg'i'sh ja'rdeminde tiyisli kesindilerdi millimetrlerde wo'lshap, 7- su'wrette keltirilgen figuralardi'n' maydani'n yesaplan'.

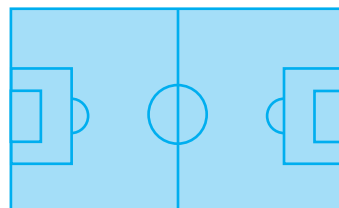

7- su'wret

8- su'wret

469. Ta'repi 8 sm bolg'an kvadratti'n' maydani' 4 sm² bolg'an neshe kvadratshag'a bo'liw mu'mkin?

470. Futbol maydani'ni'n' uzi'nli'g'i' 110 m, yeni bolsa 75 m ge ten' (8- su'wret). Futbol maydani'ni'n' maydanin yesaplan'.



471. Tuwri' to'rtmu'yeshi'n' uzi'nli'g'i' 34 sm, yeni bolsa uzi'nli'g'i'nan 12 sm qisqa bo'lsa, woni'n' maydanin tabi'n'.

472. Tuwri' to'rtmu'yeshi'n' yeni 12 sm, uzi'nli'g'i' bolsa yeninen 3 ma'рте uzun bolsa, woni'n' maydanin tabi'n'.

478. $S = ab$ formulasi'nan paydalani'p woni'n' maydani'n tabi'n';

a	22 sm	333 m		71 m	423 sm
b	54 sm	11 m	32 dm		9 dm
S			3232 dm ²	3692 m ²	



479. Ta'repi 8 dm bolg'an kvadrat formasi'ndagi'i qag'az ta'repi 1 sm bolg'an kvadrat formasi'ndagi'i bo'leklerge bo'lindi. Na'tiyjede neshe bo'leksheler payda boldi'?

480. Ta'repi 12 sm bolg'an kvadratti' maydani' 36 sm² bolg'an neshe kvadratlarga bo'liw mu'mkin.

481. 13-su'wrette boyap ko'rsetilgen figurani'n' maydani'n tabi'n':

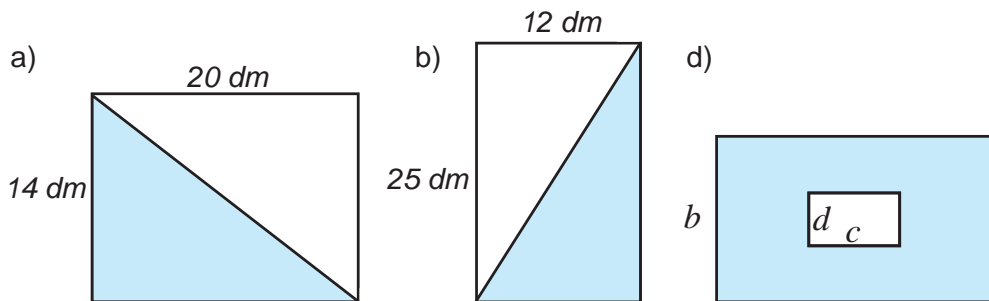

13- su'wret

Qi'ziqli' matematikag'a tiyisli ma'seleler



14.a-su'wrettegi 5 sho'ptin' worni'n sonday yetip almasti'ri'n', na'tiyjede 3 kvadrat payda bolsi'n.

14.b-su'wrettegi 2 sho'ptin' worni'n sonday yetip almasti'ri'n', na'tiyjede 5 ten'dey kvadrat payda bolsi'n.

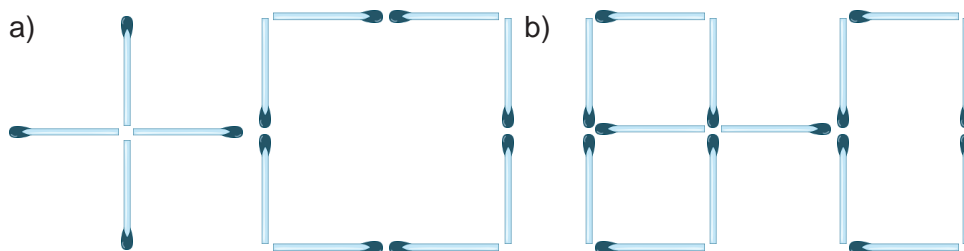

14- su'wret

22- §.

MAYDAN WO'LSHEM BI'RLI'KLERI'

Figuralardi'n' maydani'n wo'lshew ushi'n tu'rli wo'lshe**m** birliklerinen paydalaniladi'. Siz maydanni'n' kvadrat millimetr (mm^2), kvadrat santimetr (sm^2), kvadrat detsimetr (dm^2), kvadrat metr (m^2) wo'lshe**m** birliklerin bilesiz.

Qishloq xo'jaligida katta yer maydonlari yuzini o'lchash uchun **gektar** (ga) dan foydalaniladi. 1 gektar deb tomoni 100 m bo'lgan kvadrat yuzi qabul qilingan.

Demak, 1 ga = 100 · 100 kvadrat metr yamasa

$$1 \text{ ga} = 10\,000 \text{ m}^2.$$

Kishi jer maydanlari'ni'n' maydani' **ar** (*sotix*) da wo'lshe**n**edi. 1 ar bul ta'repi 10 m bolg'an kvadrat maydan.

Demek, 1 ar = 10 · 10 kvadrat metr, yamasa

$$1 \text{ ar} = 100 \text{ m}^2.$$

Joqari'dag'i'lardan to'mendegige iye bolami'z:

$$1 \text{ ga} = 100 \text{ ar}.$$

Yeger tuwri'mu'yeshliktin' uzi'nli'g'i' ha'm yeni metrlerde berilgen bolsa, woni'n'maydani' kvadrat metrlerde an'latiladi'. Yeger tuwri'mu'yeshliktin' ta'repleri tu'rl wo'lshe**m** birliklerde berilgen bolsa, aldi'n wolardi' birdey (a'dette yen' kishi) wo'lshe**m** birliklerge keltirip, son' maydan yesaplanadi'..

1-mi'sal. Yeger tuwri'mu'yeshliktin' yeni 25 sm, uzi'nli'g'i' bolsa, 1 m 20 sm bolsa, woni'n' maydani'n tabi'n'.

Sheshiliwi. Aldi'n tuwri'mu'yeshliktin' uzi'nli'g'i'n sm de an'latami'z:

$$1 \text{ m } 20 \text{ sm} = 120 \text{ sm}.$$

Wonda tuwri'mu'yeshliktin' maydani'

$$S = a \cdot b = 120 \cdot 55 = 6600 \text{ (sm}^2\text{)}.$$

55 sm

S - ?

1 m 20 sm

Juwap: 3000 sm^2 .



Sorawlarg'a juwap berin'!

1. Maydan wo'lshe**m** birliklerin ayti'n'.
2. Gektar ha'm ar ne?
3. Maydan wo'lshe**m**lerin bir-biri menen baylani'sti'ratug'i'n qatnaslardi' jazi'n'.



Klasta wori'nlanatug'i'n shi'ni'g'i'wlar

482. To'mendegi sxema tiykari'nda sorawlarg'a juwap berin':

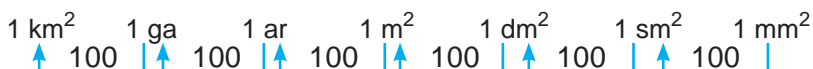

- a) 1 sm^2 neshe mm^2 ?
- d) 1 m^2 neshe dm^2 ?
- f) 1 ga neshe sm^2 ?

- b) 1 dm^2 neshe mm^2 ?
- e) 1 ar neshe sm^2 ?
- g) 1 km^2 neshe ar?

483. Maydani': a) 1 sm²; b) 1 dm²; d) 1 m²; e) 1 ar; f) 1 ga bolg'an kvadratti'n' ta'repinin' uzi'nli'g'i' qansha boladi'?
484. Kvadrat santimetrde an'lati'n': 7 dm², 12 dm², 400 mm², 1 dm² 35 sm².
485. Tuwri'mu'yeshlik formasi'ndag'i' ati'zdi'n' yeni 25 m ha'm uzi'nli'g'i' 80m. Woni'n' maydani'n tabi'n' ha'm arda an'lati'n'.
486. Tuwri'mu'yeshlik formasi'ndag'i' jer maydani'ni'n' wo'lishemi 500 m ha'm 380 m. Woni'n' maydani'n tabi'n' ha'm gektarda an'lati'n'..
487. $S = v \cdot t$ yamasa $P = 2a + 2b$ formulalardan paydalani'p kesteni tolti'ri'n:

a)

a	22 sm 8 mm	9 dm 3 sm
b	4 sm 9 mm	
P		2 m 3 dm

b)

S	3150 km	672 km	
v		56 km/saat	3 m/s
t	7 soat		3 min

488. Tuwri'mu'yeshliktin' uzi'nli'g'i' 4 sm 8 mm, yeni bolsa uzi'nli'g'i'nan 2 sm 4 mm uzi'n bolsa, woni'n' maydani'n tabi'n'.
489. Yeger bir ketek maydani' 1 sm² bo'lsa, 1- su'wrette su'wretlengen tuwri' to'rtmu'yeshler maydani'n tabi'n'.

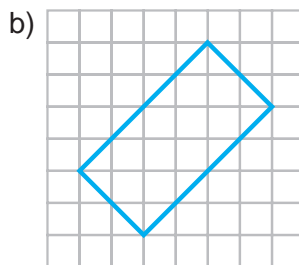
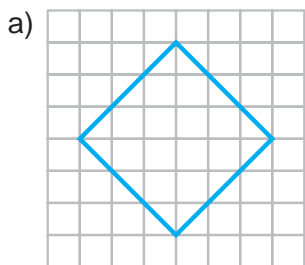

1- su'wret



490. Tuwri' to'rtmu'yeshstin' yeni 13 dm 5 sm, uzi'nli'g'i' bolsa yeninen 3 ma'rte uzi'n bolsa, uwoni'n' maydani'n tabi'n'.
491. Tuwri' to'rtmu'yeshstin' yeni 13 dm 5 sm, uzi'nli'g'i' bolsa yeninen 3 ma'rte uzi'n bolsa, uwoni'n' maydani'n tabi'n'?
492. (*A'meliy jumi's*) Tiyisli wo'lishew jumi'slari'n wori'nlap, da'pter beti, parta, klass doskasi'n, klass poli'n, sport maydانشasi'ni'n' maydani'n tabi'n'.
493. 2-su'wrette jer sxemasi' su'wretlengen. Wonnan paydalani'p jerdin' maydani'n tabi'n'.

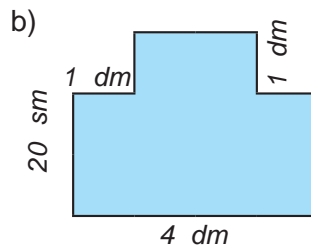
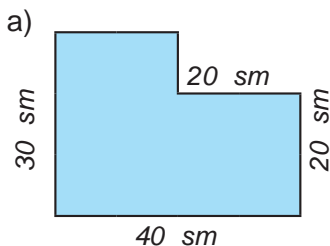

2- su'wret

494. 3.a-su'wrettegi u'shmu'yeshliktin' maydani'n yesaplaw formulasi'n jazi'n'. Wonnan paydalani'p qalg'an u'shmu'yeshliklerdin' maydani'n tabi'n'.

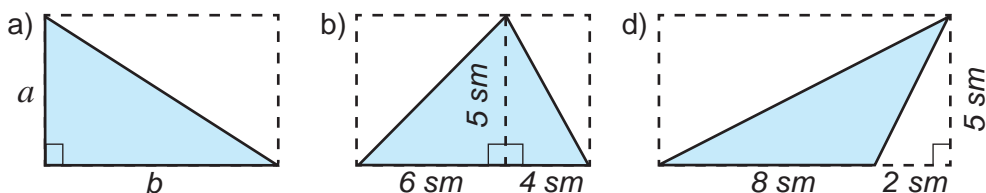

2- su'wret



U'yde wori'nlanatug'i'n shi'ng'i'wlar

495. Maydani': a) 4 sm^2 ; b) 16 dm^2 ; d) 81 m^2 ; e) 9 ar; f) 25 ga bolg'an kvadratti'n ta'repinin' uzi'nli'g'i' qansha boladi'?
496. Kvadrat metrde an'lati'n': a) 5 km^2 ; b) 800 dm^2 ; d) 9 ar.
497. Tuvri'mu'yeshlik formasi'ndag'i' ati'zdi'n' yeni 60 m, uzi'nli'g'i' 70 m. Woni'n' maydani'n tabi'n' ha'm arda an'lati'n'.
498. Tuvri'mu'yeshlik formasi'ndag'i' jer maydani'ni'n' wo'lshemleri 750 m ha'm 440 m.



499. Tuvri'mu'yeshliktin' uzi'nli'g'i' 32 dm 9 sm, yeni bolsa uzi'nli'g'i'nan 22 sm qi'sqa bolsa, woni'n' maydani'n tabi'n'.
500. Tuvri'mu'yeshliktin' yeni 45 dm 8 sm, uzi'nli'g'i' bolsa yeninen 2 yese uzi'n' bolsa, woni'n' maydani'n tabi'n'.
501. 4-su'wrettegi u'shmu'yeshliktin' maydani'n tabi'n'.

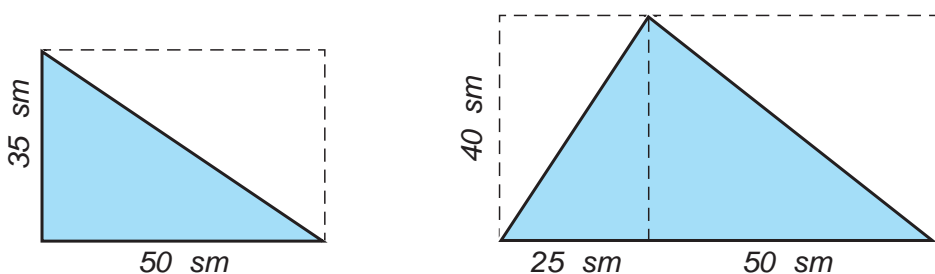

4- su'wret

23- §.

TUWRI MU'YESHLI' PARALLELEPI'PED HA'M KUB

1-su'wrettegi miywe ishimliginin' i'di'si', wo'shargish, gerbish ha'm taxta bo'legi ko'rinishine qarap, *tuwri'mu'yeshli parallelepiped* haqqi'nda tu'sinikka iye boli'w mu'mkin.



1- su'wret

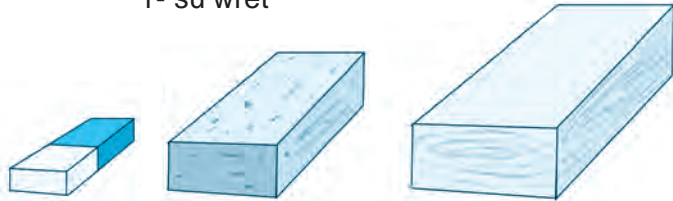

Tuwri'mu'yeshli parallelepipedtin' si'rti' 6 tuwri' to'rtmu'yeshsten ibarat (2-su'wret). Wolar tuwri'mu'yeshli parallelepipedtin' *jaqlari'* dep ataladi'.

Tuwri'mu'yeshli parallelepipedtin' qarama-qarsi' jaqlari wo'zaro ten' boladi'.

Tuwri'mu'yeshli parallelepiped si'rti'ni'n' maydani' woni'n' barli'q jaqlari' maydanlari'ni'n' ji'yi'ndi'si'nan ibarat boladi'.

Tuwri'mu'yeshli parallelepiped jaqlari'ni'n' ta'repleri parallelepipedtin' *qi'rlari'*, ushlari' bolsa parallelepipedtin' *ushlari'* dep ataladi'.

Tuwri'mu'yeshli parallelepipedtin' 8 ushi', 12 qi'ri' ha'm 6 jag'i' bar.

Tuwri'mu'yeshli parallelepipedtin' ha'r bir ushi'nan woni'n' u'sh qi'ri' shiqsa tuwri'mu'yeshli parallelepipedtin' ha'r bir to'besinen wowni'n' 3

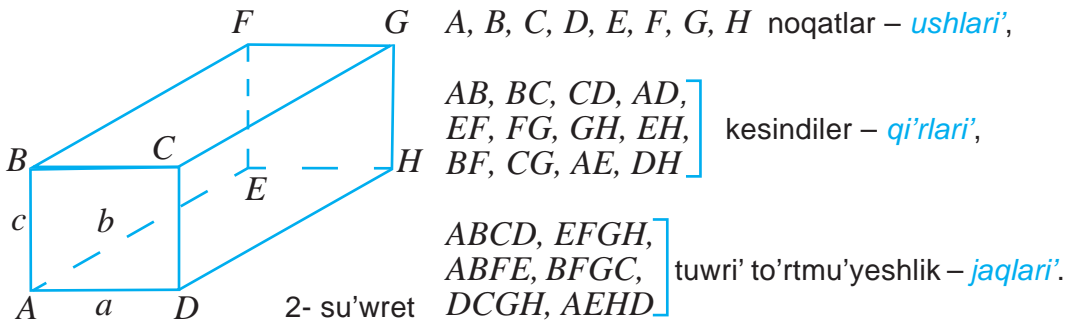

qi'ri' shi'g'adi'. 2-su'wrette A to'besinen shi'g'i'wshi' qi'rlar uzi'nli'g'i' *a, b, c* ha'ripler menen belgilengen. Bul qi'rlar sa'ykes tu'rde tuwri'mu'yeshli parallelepipedtin' *yeni, uzi'nli'g'i'* ha'm *biyikligi* dep ataladi'. Solay yetip, ha'r qanday tuwri'mu'yeshli parallelepiped u'sh wo'lishemge: *a* – yeni, *b* – uzi'nli'g'i' ha'm *c* – biyikligine iye.

Shunday qilib, har qanday to'g'ri burchakli parallelepiped uch o'lchamga: *a* – eni, *b* – bo'yi va *c* – balandligiga ega.

Barli'q qi'rlari'ten' bolg'an tuwri'mu'yeshli parallelepiped *kub* dep ataladi' (3- su'wret).

Bizge belgili, kubti'n' barli'q jaqlari' bir-birine ten' bolg'an kvadratlardan ibarat boladi'.

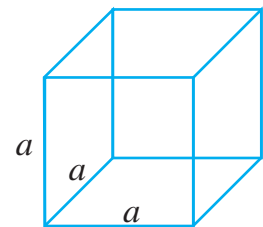

3- su'wret

1- mi'sal. 4.a-su'wrette su'wretlengen tuwri'mu'yeshli parallelepipedtin' wo'lshemleri: 5 sm, 3 sm ha'm 2 sm. Bul parallelepiped betinin' maydani'n tabi'n'.

Sheshiliwi. Bizge belgili, tuwri'mu'yeshli parallelepiped betinin' maydani' woni'n' barli'q jaqlari' uzi'nli'qlari'ni'n' qosi'ndi'si'na ten'. Berilgen tuwri' mu'yeshli parallelepipedtin' jaqlari' $ABCD$, $EFGH$, $ADGH$, $BEFC$, $ABEH$, $CFGD$ tuwri'mu'yeshliklerinen ibarat.

Soni'n' menen birge, qarama-qarsi' jatqan jaqlari' wo'z ara ten' boladi'. Buni' tuwri' mu'yeshli parallelepiped jayi'lmasi'nan da ko'riw mu'mkin (4.b- su'wret).

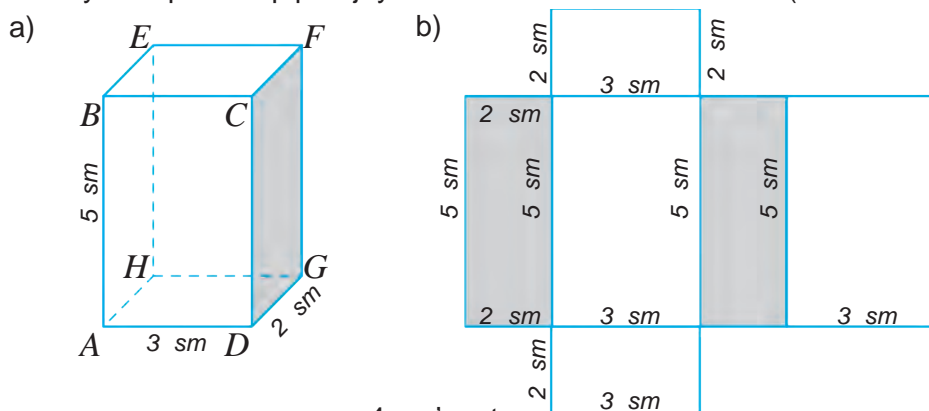

4- su'wret

Haqiyqattan da, $ABCD$ ha'm $EFGH$ jaqlar – ta'repleri 3 sm ha'm 5 sm bolg'an tuwri'mu'yeshlikten ibarat. Bul to'rtmu'yeshliktin' maydani' $3 \cdot 5 = 15$ (sm^2) ke ten'.

$ADGH$ ha'm $BEFC$ jaqlar – ta'repleri 3 sm ha'm 2 sm bolg'an tuwri'mu'yeshlikten ibarat. Bul to'rtmu'yeshliktin' maydani' $3 \cdot 2 = 6$ (sm^2) qa ten'.

$ABEH$ ha'm $CFGD$ jaqlar – ta'repleri 2 sm ha'm 5 sm bolg'an tuwri'mu'yeshlikten ibarat. Bul to'rtmu'yeshliktin' maydani' $2 \cdot 5 = 10$ (sm^2) g'a ten'.

Demek, berilgen tuwri'mu'yeshli parallelepiped betinin' maydani'

$$2 \cdot 15 + 2 \cdot 6 + 2 \cdot 10 = 30 + 12 + 20 = 62 \text{ (sm}^2\text{) ge ten' boladi'.$$

Juwap. 62 sm^2 .

Uli'wma jag'dayda, wo'lshemleri a , b ha'm c bolg'an tuwri' mu'yeshli parallelepiped betinin' maydani':

$$S = 2(ab + bc + ac)$$

formulasi' menen an'lati'ladi'.

Qabi'rg'asi' a bolg'an kub betinin' maydani':

$$S = 6a^2$$

formula menen ani'qlanadi'.



Sorawlarg'a juwap berin'!

1. Tuwri'mu'yeshli parallelepipedtin' formasi'ndag'i'larg'a mi'sal keltirin'.
2. Tuwri'mu'yeshli parallelepipedtin' neshe jag'i', qi'ri' ha'm to'besi bar?
3. Tuwri'mu'yeshli parallelepipedtin' qi'rlari' qanday figuradan barat boladi'?
4. Tuwri'mu'yeshli parallelepipedtin' jaqlari' qanday figuradan ibarat boladi'?
5. Kub dep nege ayti'ladi'?

Klasta wori' nlanatug'i'n shi'ni'g'i'wlar



502. (*A'meliy shi'ni'g'i'w*) 5- su'wrette berilgen u'lgi boyi'nsha da'pterin'izge tuwri'-mu'yeshli parallelepiped si'zi'n'. Tuwri'mu'yeshli parallelepipedtin' to'belerin belgilen'. Woni'n' barli'q to'beleri, qi'rlari' ha'm jaqlari'n jazi'n'. Woni'n' qaysi' qi'rlari' o'z ara ten' boladi'? woni'n' qaysi' jaqlari' wo'z ara ten' boladi'?

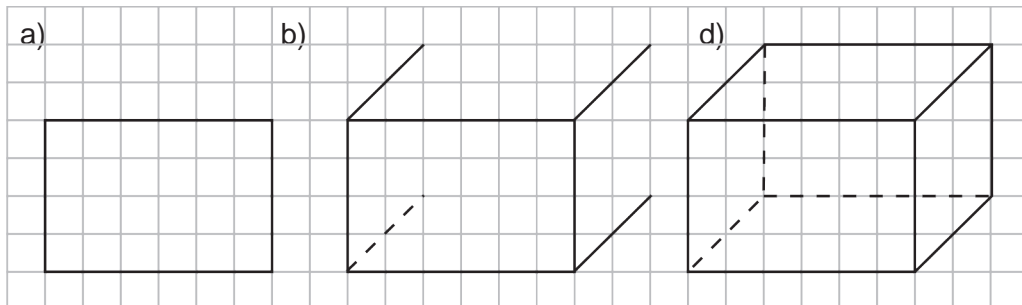

5- su'wret

503. Yeni 24 sm, uzi'nli'g'i' 32 sm ha'm biyikligi 18 sm bolg'an tuwri'mu'yeshli parallelepipedtin' qi'rlari' si'mnan jasaldi'. Buni'n' ushi'n qansha si'm isletilgen?

504. Quti'ni' 5-su'wrette su'wretlengendey yetip baylaw ushi'n qansha jip kerek boladi'?

505. Tuwri'mu'yeshli parallelepipedtin' wo'lshemleri a , b ha'm c bolsa, woni'n' qi'rlari' uzi'nli'qlari'ni'n' qosi'ndi'si'n yesaplaw formulasi'n jazi'n'.

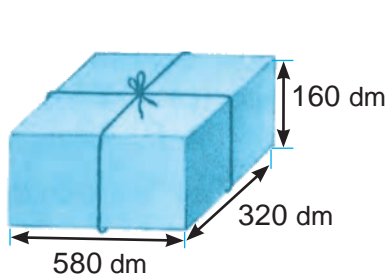

6- rasm

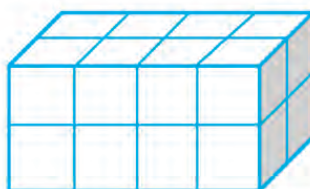

7- rasm

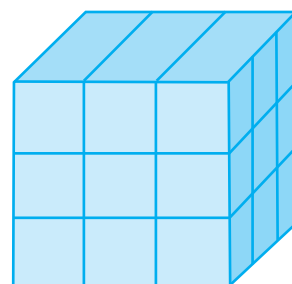

8- rasm



506. Qi'ri' 3 sm bolg'an kublardan 7- su'wrettegi parallelepiped jasaldi'. Payda bolg'an parallelepipedtin' yeni, uzi'nli'g'i' ha'm biyikligin tabi'n'. Bul parallelepiped neshe kubtan du'zilgen?

507. Qi'ri' 3 dm bolg'an ag'ash kub beti qi'zi'l ren'ge boyaldi' (8- su'wret). Sonnan son' wol qi'ri' 1 dm bolg'an kublarga bo'lip kesildi.

a) Na'tiyjede neshe kub payda boldi'?

b) Wolardi'n' arasi'nda neshewinin' bir jag'i', neshewinin' yeki jag'i' ha'm neshewinin' u'sh jag'i' boyalg'an boladi'? Hesh bir jag'i' boyalmag'an kublarda payda boladi' ma?

508. Wo'lshemleri 12 dm, 21 dm ha'm 14 dm bolg'an tuwri'mu'yeshli parallelepipedtin' betinin' maydani'n yesaplan'.

U'lg'i: Joqari'da ko'rilgen 1-mi'sal.

509. 9- su'wrette su'wretlengen tuwri'mu'yeshli parallelepiped formasi'ndag'i u'sti ashi'q akvariumdi' sog'i'w ushi'n neshe ha'm qanday wo'lsheemdegi ayna bo'lekleri kerek boladi'?

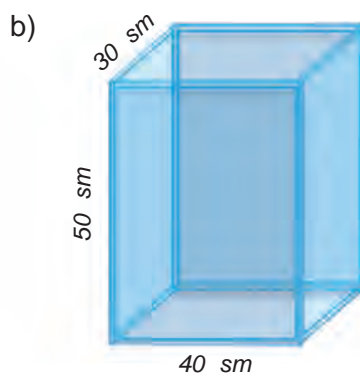
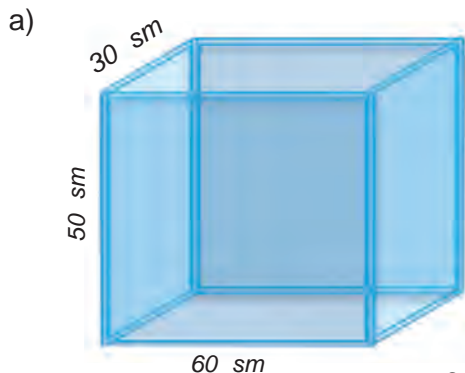

9- su'wret



510. Qi'ri' 6 sm bolg'an kubti' boyaw kerek. Buni'n' ushi'n qanday u'lkenliktegi maydandi' boyaw kerek boladi'?

511. 10-su'wrettegi dene neshe kubtan quralg'an?

512. Ren'li qag'azdi'n' wo'lshemleri 16 sm ha'm 6 sm. Bul qag'az qi'ri' 4 sm bolg'an kubti' qaplaw ushi'n jeterli bolama?

513. Ren'li qag'az wo'lshemleri 12 sm ha'm 8 sm. Bul qag'az yeni 3 sm, uzi'nli'g'i' 4 sm ha'm biyikligi 5 sm bolg'an parallelepipedti qaplaw ushi'n jeterli bolama?

514. Tuwri'mu'yeshli parallelepipedtin' wo'lshemleri a) 6 sm; 9 sm ha'm 13 sm; b) 8 sm, 12 sm, 15 sm; d) 4 sm, 21 sm ha'm 30 sm bolsa, woni'n' betinin' maydani'n tabi'n'.

515. Wo'lshemleri 9 dm, 15 dm ha'm 18 dm bolg'an tuwri'mu'yeshli parallelepipedtin' betin boyaw kerek. yeger 1 dm² maydandi' boyaw ushi'n 2 g boyaw kerek bolsa, parallelepipedtin' betin boyaw ushi'n qansha boyaw kerek boladi'?

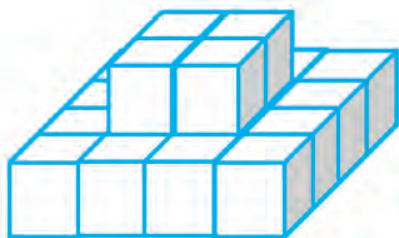

10- su'wret

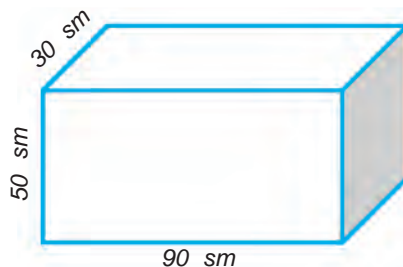

11- su'wret

U'yde wori'nlanatug'i'n shi'ng'i'wlar



- 516.** 11- su'wret tuwri'mu'yeshli parallelepiped berilgen. Woni'n' to'belerin belgilen' ha'm barli'q qi'rlari'ni'n' uzi'nli'g'i'n' tabi'n'. Bul qi'rlardi'n' qaysi'lari' wo'z ara ten' boladi'? Woni'n' barli'q jaqlari'n' jazi'n' ha'm wo'lshemlerin ani'qlan'. Bul jaqlardi'n' qaysi'lari' wo'z ara ten' boladi'?
- 517.** Yeni 12 sm, uzi'nli'g'i' 25 sm ha'm biyikligi 13 sm bolg'an tuwri'mu'yeshli parallelepipedtin' qi'rlari' si'mnan sog'i'lg'an. Buni'n' ushi'n qansha si'm jumsalg'an?



- 518.** Qi'ri' a g'a ten' bolg'an kub qi'rlari'ni'n' uzi'nli'qlari'ni'n' qosi'ndi'si'n yesapalaw formulasi'n jazi'n.
- 519.** Ren'li qag'azdi'n' wo'lshemleri 12 sm ha'm 7 sm. Bul qag'azdi'n' yeni 4 sm, uzi'nli'g'i' 6 sm ha'm biyikligi 2 sm bolg'an tuwri'mu'yeshli parallelepipedti qaplaw ushi'n jeterli bolama?



- 520.** Tuwri'mu'yeshli parallelepipedtin' wo'lshemleri a) 3 sm, 6 sm ha'm 7 sm; b) 11 dm, 13 dm ha'm 13 dm; d) 40 dm, 9 dm ha'm 6 dm bolsa, woni'n' betinin' maydani'n tabi'n'.
- 521.** O'lshemleri 40 sm, 30 sm ha'm 20 sm bolg'an tuwri'mu'yeshli parallelepiped formasi'ndag'i' taxtay bo'leginin' betin boyaw kerek. yeger 1 dm^2 maydandi' boyaw ushi'n 2 g boyaw kerek bolsa, parallelepiped betin boyaw ushi'n qansha boyaw kerek boladi'?

24- §.

**KO'LEM. KO'LEM WO'LSHEM BI'RLI'KLARI'.
TUWRIMU'YESHLI' PARALLELEPIPEDTIN' KO'LEMI**



Biri suw menen toltiri'lg'an, yekinshisi bos bolg'an yeki shiyshe i'di's alami'z (1.a- su'wret). Birinshi i'di'stag'i' suwdi' yekinshisine quyami'z. Yeger birinshi i'di'stag'i' barli'q suw yekinshi i'di'sqa si'yi'p, woni' toli'q toltirsa (1.b- su'wret), bul - yeki i'di's birdey si'yi'mli'li'qqa yamasa ko'lemge iye yekenin bildiredi.

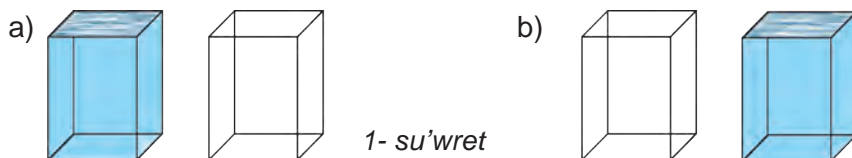

Biri suw menen toltiri'lg'an, yekinshisi bolsa bos bolg'an ja'ne basqa yeki shiyshe i'di's alami'z (2.a-su'wret).

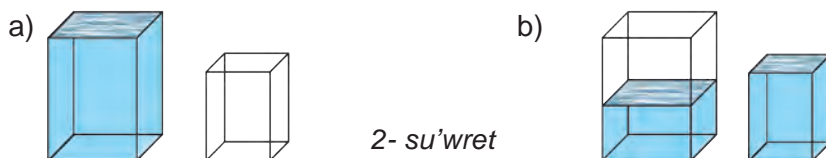

Birinshi i'di'stag'i' suwdi' yekinshi i'di'sqa quyami'z. Bul jag'dayda yekinshi i'di's toli'q tolg'annan keyin de birinshi i'di'sta suw qalsa (2.b-su'wret), bul birinshi i'di'sti'n' ko'lemi yekinshisinin' ko'lemiden u'lken yamasa yekinshi i'di'sti'n' ko'lemi birinshisikinen kishi yekenligin bildiredi.

24.1. Ko'lem tu'sinigi

Qanday da bir shamani' wo'lshew ushi'n wo'lshe m birligin tan'law lazi'm boladi'. Yadi'n'i'zda bolsa kerek, kesindinin' uzi'nli'g'i'n wo'lshe w ushi'n aldi'n uzi'nli'q wo'lshe m birligi – birlik kesindini (3.a-su'wret), tuwri'mu'yeshliktin' maydani'n wo'lshe w ushi'n bolsa maydan wo'lshe m birligi si'pati'nda kvadratti' (3.b-su'wret) tan'lag'an yedik.

Tap sog'an uqsas, qanday da bir figurani'n' ko'lemin wo'lshe w ushi'n da aldi'n ko'lem wo'lshe m birligi tan'lanadi'. Ko'lem wo'lshe m birligi si'pati'nda birlik kub ali'nadi' (3.d-su'wret).

Birlik kub dep qi'ri'ni'n' uzi'nli'g'i' birlik kesindige ten' bolg'an kubqa ayti'ladi'.

Ma'selen, *1 kub santimetr* – qi'ri' 1 sm ge ten' bolg'an kub ko'lemine ten'. Bul ko'lem birligi *sm³* ko'rinishinde jazi'ladi' ha'm *kub santimetr* dep wo'qi'ladi'.



Qanday da bir figurani'n' ko'lemin wo'lshe w degende bul figurag'a birlik kubtan neshewin jaylasti'ri'w mu'mkinligin ani'qlawg'a ayti'ladi'

4-su'wrette su'wretlengen figura qi'ri' 1 sm ge ten' bolg'an 6 kubtan ibarat. Demek, woni'n' ko'lemi 6 sm^3 qa ten'.

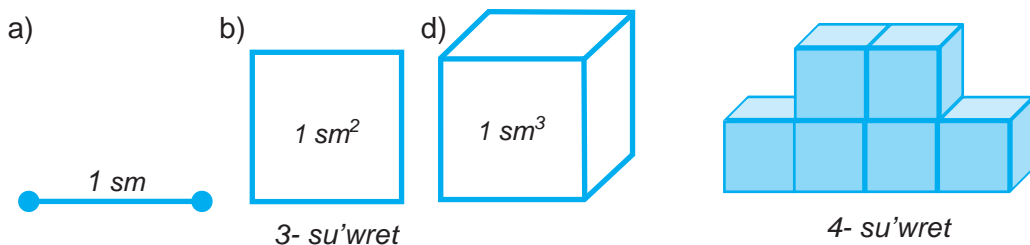

24.2. Tuwri'mu'yeshli parallelepipedtin' ko'lemi

Tuwri'mu'yeshli parallelepipedtin' ko'lemin yesaplaw qag'i'ydasin tabayi'q. Aytayi'q, tuwri'mu'yeshli parallelepiped formasi'ndag'i' quti'ni'n' uzi'nli'g'i' 3 sm, yeni 2 sm, biyikligi bolsa 5 sm bolsi'n (4.a-su'wret). Woni' qi'ri' 1 sm ge ten' bolg'an kublar menen tolti'ramiz, yag'ni'y woni'n' ko'lemin sm^3 ta wo'lsheymiz.

Wonda quti'ni'n' to'mengi ultani'na ja'mi $3 \cdot 4 = 12$ kub bir qabat boli'p jaylasadi' (4.b- su'wret). Quti'ni' kublar menen toli'q tolti'ri'w ushi'n bolsa bunday qabatlardan 5 yewin u'stpe-u'st qoyi'w kerek boladi' (5.b- rasm), sebebi woni'n' biyikligi 5 sm ge ten'. Solay yetip, quti'g'a ja'mi $(3 \cdot 4) \cdot 5 = 60$ kubti' jaylasti'ri'w mu'mkin yeken.

Demek, quti'ni'n' ko'lemi 60 sm^3 ke ten' boladi'.

I'tibar bersen'iz, tuwri'mu'yeshli parallelepiped formasi'ndag'i' bul quti'ni'n' ko'lemi woni'n' u'sh wo'lsheymi: yeni, uzi'nli'g'i' ha'm biyikliginin' ko'beymesine ten' boladi'.

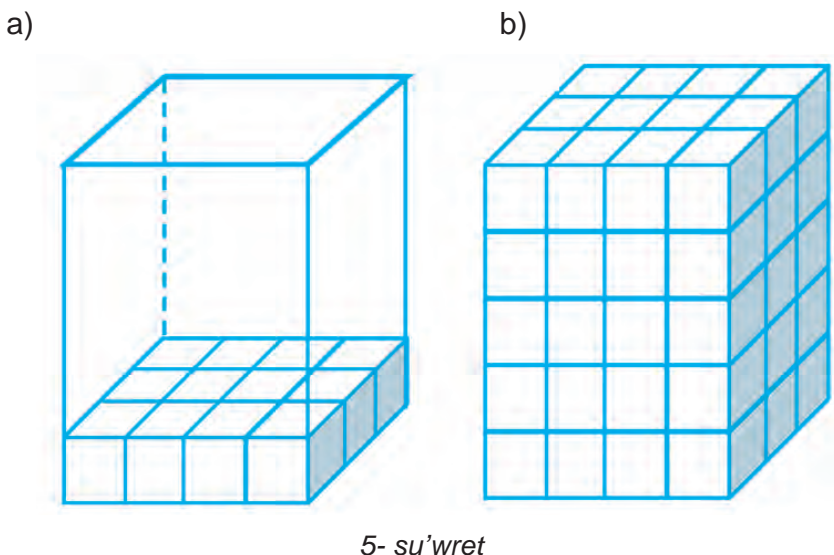

Tuwri'mu'yeshli parallelepipedtin' ko'lemi—uzi'nli'g'i', yeni ha'm biyikligi ko'beymesine ten'.



Yeger tuwri'mu'yeshli parallelepipedtin' ko'lemin – V , uzi'nli'g'i'n – a , yenin – b ha'm biyikligin – c ha'ripleri menen belgilesek (6- su'wret), wonda to'mendegi formulag'a iye bolami'z:

$$V = a \cdot b \cdot c$$

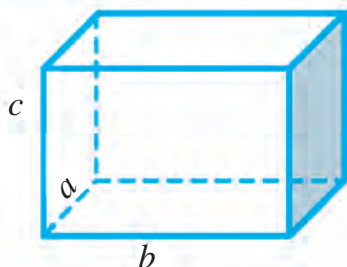

$$V = abc$$

6- su'wret

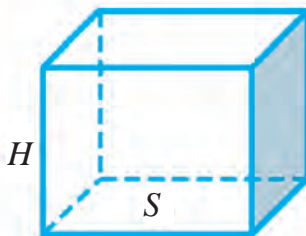

$$V = S H$$

7- su'wret

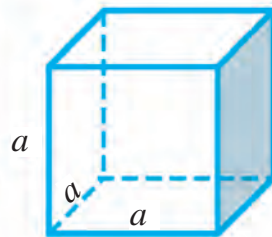

$$V = a^3$$

8- su'wret

Biraq, tuwri'mu'yeshli parallelepiped yeni ha'm uzi'nli'g'i'ni'n' ko'beymesini ($a \cdot b$) woni'n' ultani'ni'n' maydani'na ten' (7- su'wret). Soni'n' ushi'n, parallelepiped ultani'n' maydani'n – S ha'm biyikligin – H ha'ripleri menen qayta belgilesek, wonda tuwri'mu'yeshli parallelepiped ko'lemin tabi'w ushi'n taza formulag'a iye bolami'z:

$$V = S \cdot H$$

Yendi qi'ri' 5 sm ge ten' bolg'an kubtin' ko'lemin tabayi'q. Kubta tuwri'mu'yeshli parallelepiped bolg'ani' ushi'n woni'n' ko'lemi $5 \cdot 5 \cdot 5 = 125$ (sm³) qa ten' boladi'. Uli'wma jag'dayda, qi'ri' a g'a ten' bolg'an kubtin' ko'lemi a^3 ga teng bo'ladi.

Umumiy holda, qirrasi a ga teng bo'lgan kubning hajmi

$$V = a^3$$

formula menen an'latiladi' (8- su'wret).

24.3. Ko'lem wo'lishew birlikleri

Ko'lemlerdi wo'lishew ushi'n kub millimetr (mm³), kub detsimetr (dm³), kub metr(m³), kub kilometr (km³) si'yaqli' wo'lishem birliklerinen paydalani'ladi'.

Suyi'qli'qlar menen jumi's ko'rilgende 1 dm³ ti' basqasha litir (l) dep te ataydi'.

$$1 \text{ litr} = 1 \text{ dm}^3$$

Yendi ko'lem wo'lishem birlikleri arasi'ndagi' bazi' bir qatnaslardi' ani'qlayiq. Bizge belgili 1 m = 10 dm. Bunda:

$$1 \text{ m}^3 = 1 \text{ m} \cdot 1 \text{ m} \cdot 1 \text{ m} = 10 \text{ dm} \cdot 10 \text{ dm} \cdot 10 \text{ dm} = 1000 \text{ dm}^3$$

Demak,

$$1 \text{ m}^3 = 1000 \text{ dm}^3.$$

Tap usi'g'an uqsas,

$$1 \text{ dm}^3 = 1000 \text{ sm}^3, \quad 1 \text{ m}^3 = 1\,000\,000 \text{ sm}^3, \quad 1 \text{ km}^3 = 1\,000\,000\,000 \text{ m}^3$$

yekenligin de ani'qlaw mu'mkin.

Sorawlarg'a juwap berin'!



1. Yeki i'di'sti'n' si'yi'mli'li'g'i' (ko'lemi) qalay sali'sti'ri'ladi'?
2. Ko'lem wo'lshem birligi si'pati'nda ne ali'nadi'?
3. Figurani'n' ko'lemin wo'lshew degende ne tu'siniledi'?
4. Ko'lemnin' qanday wo'lshem birliklerin bilesiz'?
5. Tuwri'mu'yeshli parallelepipedtin' ko'lemin yesaplaw formulasi'n ayti'n'.

Klasta wori'nlanatug'i'n shi'ni'g'i'wlar



- 522.** 9- su'wrettegi figuralardi'n' qi'ri' 1 dm ge ten' bolg'an birlik kublardan du'zilgen. Bul figuralardi'n' ko'lemin ha'm betinin' maydani'n tabi'n'.

a)

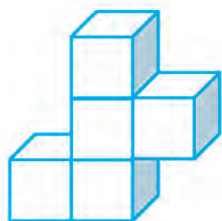

b)

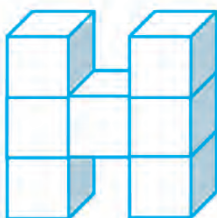

d)

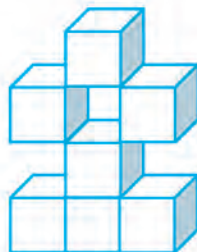

e)

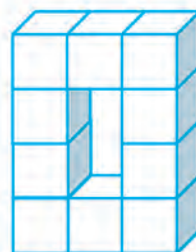

9- su'wret

- 523.** Tuwri'mu'yeshli parallelepipedte: a) $a = 12 \text{ sm}$, $b = 15 \text{ sm}$, $c = 8 \text{ sm}$;
b) $a = 18 \text{ dm}$, $b = 9 \text{ dm}$, $c = 12 \text{ dm}$. Woni'n' ko'lemin yesaplan'.
- 524.** 1 m^3 hawani'n' massasi' 1290 g . Wo'lshemleri 8 m, 6 m ha'm 3 m bolg'an klass bo'lmesinin' hawasi'ni'n' massasi'n tabi'n'.
- 525.** Ultani'ni'n' maydani' ha'm biyikligi boyi'nsha tuwri'mu'yeshli parallelepipedtin' ko'lemin tabi'n': a) $S = 15 \text{ sm}^2$, $H = 4 \text{ sm}$; b) $S = 36 \text{ dm}^2$, $H = 2 \text{ dm}$.
- 526.** Tuwri'mu'yeshli parallelepiped formasi'ndag'i' skladi'ti'n' uzi'nli'g'i' 24 m, yeni 13 m ha'm ko'lemi 3432 m^3 . Woni'n' biyikligin tabi'n'.
- 527.** Tuwri'mu'yeshli parallelepipedte: a) $V = 7290 \text{ sm}^3$, $H = 54 \text{ sm}$;
b) $V = 1170 \text{ dm}^3$, $H = 78 \text{ dm}$ bo'lsa, woni'n' ultani'n' maydani'n tabi'n'.
- 528.** Santimetrlerde an'lati'n':
a) 2 m 3 dm; || b) 18 m 7 dm; || d) 2100 mm; || e) 3 dm 30 sm 20 mm.
- 529.** Kvadrat santimetrde an'lati'n':
a) 53 dm^2 ; || b) $18\,000 \text{ mm}^2$; || d) $3 \text{ m}^2 7 \text{ dm}^2$; || e) $4 \text{ m}^2 30 \text{ dm}^2$.



530. Litrde an'lati'n':

- a) 5 dm^3 ; || b) $21\ 000 \text{ sm}^3$; || d) $3 \text{ dm}^3\ 7000 \text{ sm}^3$; || e) $2 \text{ m}^3\ 3 \text{ dm}^3$.

531. Temirden qi'ri' 20 sm bolg'an kub formasi'ndagi'i detal tayarlandi'. 10 sm^3 temir bo'leginin' massasi 78 g bolsa, detaldi'n' massasi'n tabi'n'.

532. A'tir sabi'nni'n' wo'lshemleri 8 sm, 4 sm ha'm 2 sm. Sabi'n paydalani'lg'anda ha'r ku'ni woni'n' ko'lemi 4 sm^3 qa kemeyip baradi'. Sabi'nnan neshe ku'n paydalani'w mu'mkin?

533. 10- su'wrettegi akvariumlardi'n' joqarg'i' qi'ri'ndagi'i betinen 10 sm to'men suw menen toltiri'lg'an. Ha'r bir akvariumdag'i' suw ko'lemin tabi'n'.

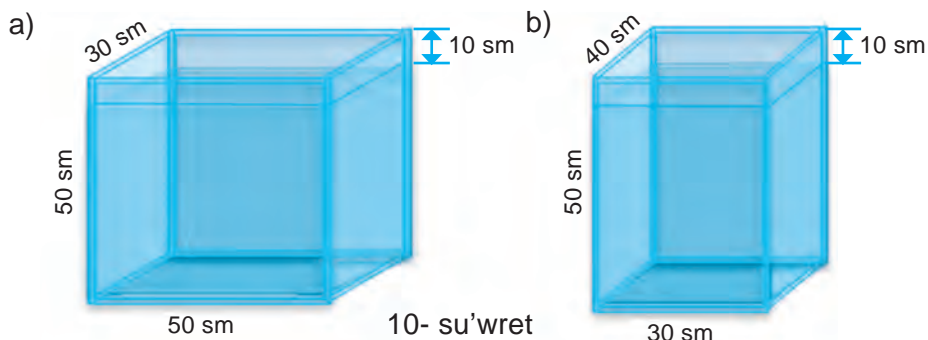

534. 11- su'wrette su'wretlengen bo'lmelerdin' wo'lshemleri boyi'nsha, poldi'n' maydani'n, diywallardi'n' maydani'n ha'm ko'lemin tabi'n'.

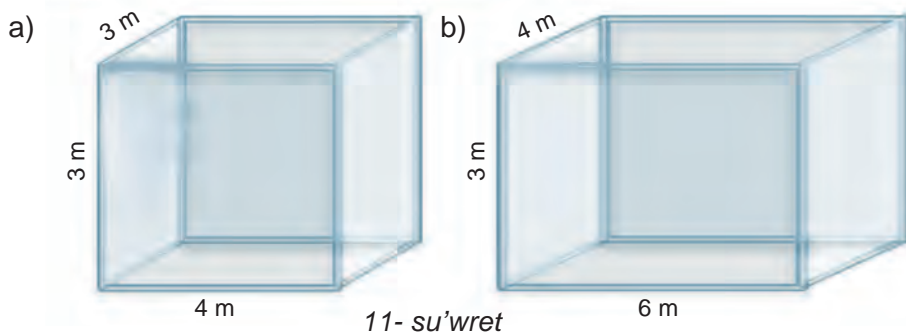

535. 12- su'wrette su'wretlengen denelerdin' ko'lemin ha'm si'rti'ni'n' maydani'n' tabi'n':

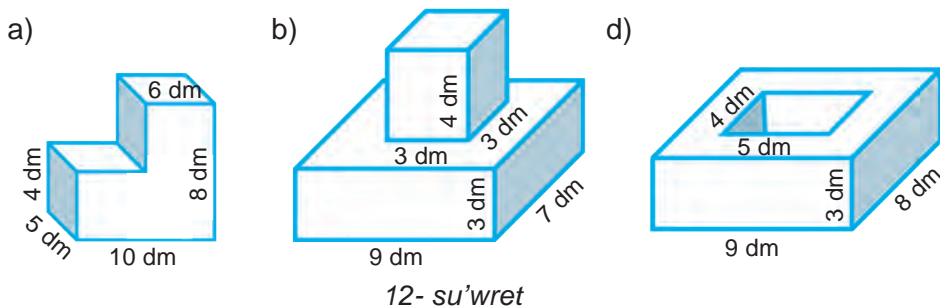

U'yde wori'nlanatug'i'n shi'ng'i'wlar



536. 13- su'wrette figuralardi'n' qi'ri' 1 dm ge ten' bolg'an birlik kublardan du'zilgen. Bul figuralardi'n' ko'lemin ha'm betinin' maydani'n' tabi'n'. Wolardi'n' arasi'ndag'i' ko'lemleri ten' bolg'an figuralardi' ani'qlan'.

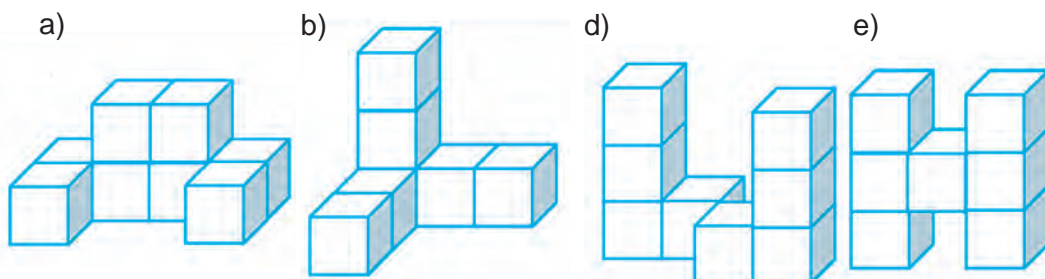

13- su'wret

537. Tuwri'mu'yeshli parallelepipedte a) $a = 6$ m, $b = 12$ m, $c = 7$ m; b) $a = 2$ dm, $b = 13$ dm, $c = 6$ dm bolsa, woni'n' ko'lemin yesaplan'.

538. Ag'ash taqtaydi'n' uzi'nli'g'i' 6 m, yeni 2 dm ha'm qali'nli'g'i' 25 sm 1 dm³. taqtaydi'n' massasi' 650 g yekenligi belgili bolsa, taqtaydi'n' massasi'n' tabi'n'.

539. Tuwri'mu'yeshli parallelepipedtin' ko'lemi 3 366 sm² ha'm biyikligi 33 sm bolsa, ultani'ni'n' maydani'n' tabi'n'.



540. Yeger bir kubikti'n' ko'lemi 1 dm³ bolsa, 14- su'wrette ko'rsetilgen denelerdi'n' ko'lemin ani'qlan'.

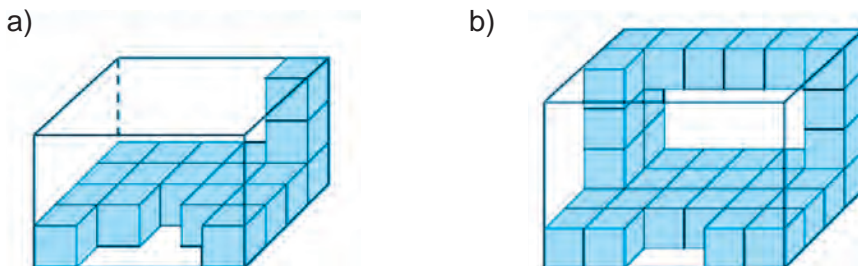

14- su'wret

541. Santimetrlerde an'lati'n':

- a) 5 m 8 dm; b) 11 m 9 dm; d) 6 m 3 dm;
e) 800 mm; f) 2 dm 12 sm 40 mm.

542. Kub santimetrlerde an'lati'n':

- a) 8 dm³; b) 22 dm³; d) 5 dm³ 80 sm³;
e) 120 000 mm³; f) 7 m³ 9 dm³.

543. Alyuminiyden wo'lshemleri 7 sm, 10 sm ha'm 12 sm bolg'an, tuwri'mu'yeshli parallelepiped formasi'ndag'i' detal tayarlandi'. 10 sm³ ko'lemdegi alyuminiy bo'leginin' massasi' 27 g bolsa, detaldi'n' massasi'n' tabi'n'.

25- §.

IV BAPTI' TA'KIRA'RLAWG'A TIYISLI MA'SELELER

25.1. Uleslerge tiyisli ma'seleler sheshiw

1- *mi'sal* Qulpi'nyaydan murabba tayarlaw ushi'n 3 ules qulpi'nayg'a 2 ules qumsheker aralasti'ri'w kerek. 18 kg qulpi'nayg'a qansha qumsheker kerek boladi'?

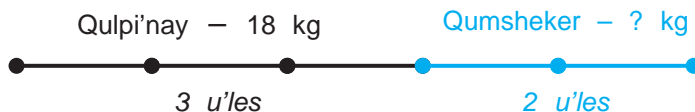

Sheshiliwi. Sha'rt boyi'nsha 18 kg qulpi'nyay 3 ulesin quraydi'. Demek, 1 ules qulpi'nyay $18 : 3 = 6$ (kg) g'a ten'. Wonda qumsheker 2 ulesin, yag'ni'y $2 \cdot 6 = 12$ (kg) quraydi'.

Juwabi'. 12 kg qumsheker aralasti'ri'w za'ru'r.

2- *mi'sal.* Biton aralaspasi'n tayarlaw ushi'n 3 ules qumg'a 2 ules tsement aralasti'ri'ladi'. 60 kg biton aralaspasi'n tayarlaw ushi'n neshe kg qum ha'm neshe kg tsement ali'w kerek?

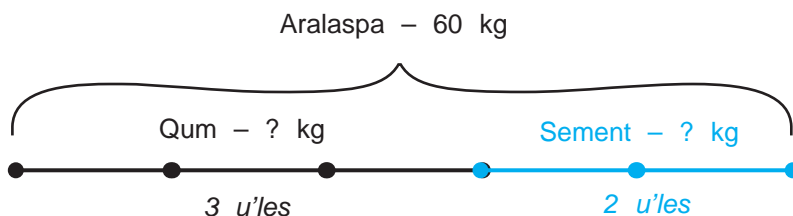

Sheshiliwi. Biton aralaspasi' ja'mi $3 + 2 = 5$ ulesinen ibarat. Wonda 1 ules aralaspasi massasi' $60 : 5 = 12$ (kg) di' quraydi'.

Demek, 60 kg biton aralaspasi' tayarlaw ushi'n qumnan 3 ules, yag'ni'y $3 \cdot 12 = 36$ (kg), tsementten bolsa 2 ules, yag'ni'y $2 \cdot 12 = 24$ (kg) kerek boladi'.

Juwabi': 36 kg qum, 24 kg tsement kerek boladi'.

25.2. IV bapti' ta'kirarlawg'a tiyisli ma'seleler

544. Basi'p wo'tilgen jol formulasi'nan paydalani'p, v – tezliktin' ma'nisin tabi'n':

a) $S = 180$ km, $t = 9$ soat; || b) $S = 140$ m, $t = 28$ s.

545. Basi'p wo'tilgen jol formulasi'nan paydalani'p, t – waqi'tti' tabi'n':

a) $S = 121$ km, $v = 11$ km/soat; || b) $S = 990$ m, $v = 11$ m/soat.

546. Tuwri'mu'yeshliktin':

a) ta'repleri $a = 302$ sm, $b = 21$ dm bolsa, woni'n' perimetri ha'm maydani'n;

b) perimetri 444 m ha'm ta'replerinen biri 120 m bo'lsa, yekinshi ta'repin tabi'n'.

547. Kvadratti'n' ta'replari 31 dm bolsa, perimetrin ha'm maydani'n tabi'n'.
548. Tuwri'mu'yeshliktin' ta'replari 56 sm ha'm 44 sm. Perimetri tuwri'mu'yeshliktin' perimetrine ten' bolg'an kvadratti'n' ta'repin tabi'n'.
549. Tuwri'mu'yeshliktin' bir ta'repi 108 sm, yekinshi ta'repi birinshisinen 4 ma'рте qisqa. Tuwri'mu'yeshliktin' perimetrin ha'm maydani'n tabi'n'.
550. Tuwri'mu'yeshlikte: a) $a = 16$ m, $b = 11$ m; b) $a = 21$ dm, $b = 430$ sm; d) $a = 20$ sm, $b = 8$ dm; e) $a = 53$ m, $b = 550$ dm bolsa, maydani' ha'm perimetrin tabi'n'.
551. Tuwri'mu'yeshlik haqqi'nda berilgen mag'li'wmatlardan paydalani'p kesteni toltiri'n';

a	23 sm	73 m		17 m
b	27 sm	19 m	23 dm	
S			1242 dm ²	1037 m ²

552. Ta'repi 2 m bolg'an kvadrat formasi'ndag'i' qali'n' qag'az ta'repi 1 dm bolg'an kishi kvadrat formasi'ndag'i' bo'lekshelerga bo'lindi. Na'tiyjede neshe bo'lekler payda boladi'?
553. Ta'repi 24 sm bolg'an kvadratti', maydani' 144 sm² bolg'an neshe kvadratlarga bo'liw mu'mkin.
554. Maydani': a) 144 sm²; b) 64 dm²; d) 576 m²; e) 121 ar; f) 169 ge bolg'an kvadratti'n' ta'repin ha'm perimetrinin' uzi'nlig'i'n tabi'n'.
555. Tuwri'mu'yeshlik formasi'ndag'i' ati'zdi'n' yeni 70 m ha'm uzi'nlig'i' 80 m. Woni'n' maydani'n tabi'n' ha'm arda an'lati'n'.
556. Tuwri'mu'yeshlik formasi'ndag'i' jer maydani'ni'n' wo'lshemleri 1500 m ha'm 2400m. Woni'n' maydani'n tabi'n' ha'm gektarda an'lati'n'.
557. Yeni 15 sm, uzi'nlig'i' 2 dm ha'm biyikligi 18 sm bolg'an tuwri'mu'yeshli parallelepipedtin' qi'rlari' si'mnan islengen. Buni'n' ushi'n qansha si'm jumsalga'n?
558. Wo'lshemleri 6 dm, 12 dm ha'm 17 dm bolg'an tuwri'mu'yeshli parallelepiped betinin' maydani'n yesaplan'.
559. Qi'ri' 25 dm bolg'an kubti' boyaw kerek. Buni'n' ushi'n qanday shamadagi' maydandi' boyaw kerek boladi'?
560. Bir kub metr hawani'n' massasi' 1290 g. Wo'lshemleri 20 m, 10 m ha'm 4 m bolg'an xanadag'i hawani'n' massasi' neshe kilogramm?
561. Tuwri' mu'yeshli parallelepiped tu'rindagi, uzi'nlig'i' 21 m, yeni 13 m ha'm teren'ligi 3 m bolg'an ura qaziw kerak. Buni'n' ushi'n qansha ko'lemdegi topi'raqti' qazi'p sh'ig'ari'w kerak boladi'?

562. Ag'ash taqtaydi'n' uzi'nlig'i' 8 m, yeni 3 dm ha'm qalin'lig'i' 30sm. 1 dm^3 taqtaydi'n' massasi' 650 g yekenligi belgili bolsa, taqtaydi'n' massasi'n tabi'n'.
563. Tuvri'mu'yeshli parallelepiped formasi'ndag'i' ji'ynali'slar zali'ni'n' uzi'nlig'i' 40 m, yeni 25 m ha'm ko'lemi 6000 m^3 . Woni'n' biyikligin tabi'n'.
564. Alyuminiyden wo'lshemleri 17 sm, 19 sm ha'm 21 sm bolg'an tuvri' mu'yeshli parallelepiped formasi'ndag'i' detal tayarlandi'. 10 sm^3 ko'lemin-degi alyuminiy bo'leginin' massasi' 27 g bolsa, detaldi'n' massasi'n tabi'n'.
565. Diywaldi'n' biyikligi 3 m, uzi'nlig'i' 30 m ha'm qalin'lig'i' 40 sm. Gerbishtin' wo'lshemleri: 30 sm, 15 sm, 10 sm. Diywaldi' quri'wg'a neshte gerbish kerek boladi'?
566. Xana poli'ni'n' yeni 6 m, uzi'nlig'i' 15 m. 1 m^2 poldi boyaw ushi'n 200 g boyaw sari'planadi. Xana poli'n boyaw ushi'n qansha boyaw kerak?



Bilimin'izdi si'nap ko'rin'!

Bul bap materiallari'n u'yrenip shi'g'i'p, to'mendegi ma'selelerdi sheshe ali'wi'n'i'z sha'rt! Qadag'alaw jumi'si'nan aldi'n wo'zin'izdi si'nap ko'rin'!

Test. Duri's juwapti' ani'qlan'

- Qanday da bir qag'i'ydani'n' ha'ripler ja'rdemindegi an'latpasi'na ne dep ataladi'?
A. Sanli' an'latpa; || **B.** Ha'ripli an'latpa; || **D.** Formula; || **E.** Ten'leme.
- Tuvri'mu'yeshli parallelepipedtin' neshe jag'i' bar?
A. 12 ta; **B.** 4 ta; **D.** 6 ta; **E.** 16 ta.
- Qaysi' juwapta kub ko'leminin' formulasi' keltirilgen?
A. $V = abc$; **B.** $V = a^3$; **D.** $S = ab$; **E.** $S = a^2$.

6- tekseriw jumi'si'ni'n' u'lgisi

- Yesaplan': a) $(5^3 + 13^2) : 21$; || b) $180 \cdot 94 - 47 \cdot 700 : 45 + 4946$.
- Tuvri'mu'yeshlik formasi'ndag'i' jer maydani'ni'n' uzi'nlig'i' 125 m, yeni 96 m. Jer maydani'ni'n' maydani'n tabi'n' ha'm woni' ar da an'lati'n'.
- Tuvri'mu'yeshli parallelepipedtin' wo'lshemleri 4 m, 3 m ha'm 5 dm. Woni'n' ko'lemin tabi'n'.
- a) Tezligi 80 km/saat bolg'an avtomashina 3 saatta qansha jol basi'p wo'tedi? b) Ko'lde 15 km/saat tezlikte 90 km ju'zgen katerdin' ju'ziw waqti'n tabi'n'.
- Qi'ri' 6 dm bolg'an kub betinin' maydani'n ha'm ko'lemin tabi'n'.

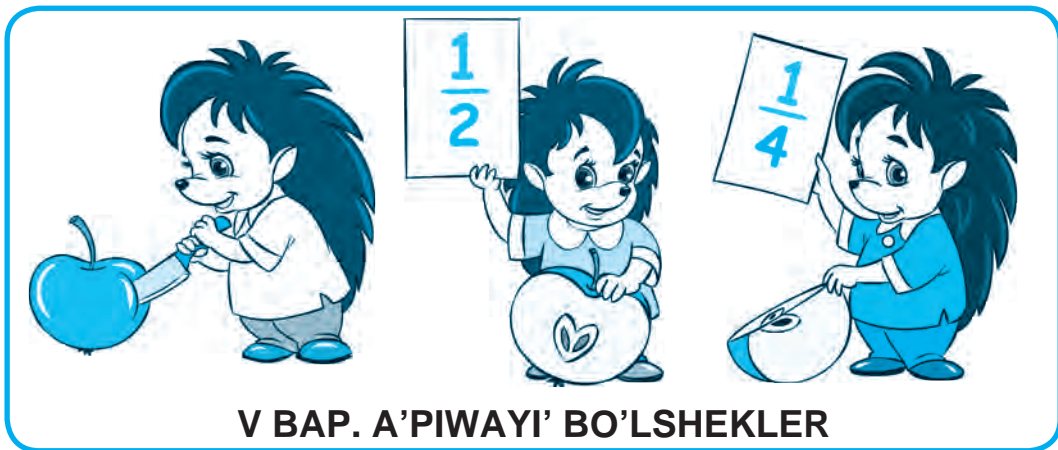

26- §. SHEN'BER HA'M DO'N'GELEK

Cirkul (parger) di'n' iyneli ushi'n O noqatqa qoyi'p, qa'lemli ushi'n usi' noqat a'tirapi'nda aylandi'ri'p si'zami'z (1- su'wret). Payda bolg'an figura *shen'ber* dep ataladi' (2- su'wret).

Shen'ber tegislikti yeki bo'lekke aji'ratadi'. Tegisliktin' shen'ber ishindegi bo'legi (shen'ber menen birgelikte) *do'n'gelek* dep ataladi' (3- su'wret).

O noqati' *shen'ber (do'n'gelek) worayi'* dep ataladi'. Shen'berdi si'zg'anda tsirkul ushlari' arasi'ndag'i' arali'q wo'zgermeydi. Soni'n' ushi'n shen'berdin' barli'q noqatlari'oni'n' worayi'nan ten'dey uzaqli'qta jatadi'.

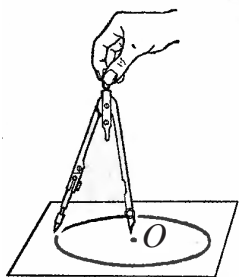

1- su'wret

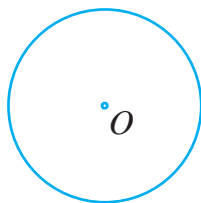

2- su'wret

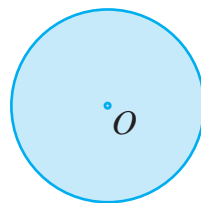

3- su'wret

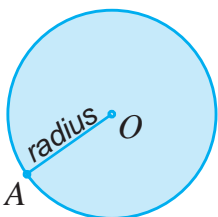

4- su'wret

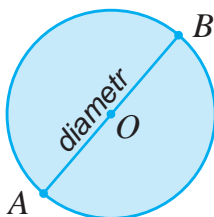

5- su'wret

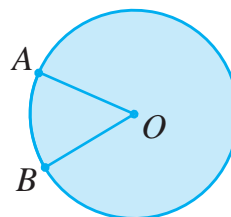

6- su'wret

Shen'berdin' O worayi'ni woni'n'qandayda bir A noqati' menen tutasti'ratug'i'n OA kesindi *shen'berdin' radiusi'* dep ataladi' (4- su'wret). Soni'n' menen birge, shen'berdin' radiusi' wol shegaralap turg'an do'n'gelektin' radiusi' da boladi'.

Bizge belgili, shen'berdin'barli'q radiuslari' bir-birine ten' boladi'.

5- su'wrette AB kesindi shen'ber (do'n'gelek) worayi'nan wo'tip, woni'n' A ha'm B noqatlari'n tutasti'ri'p ati'r. AB kesindi *shen'ber (do'n'gelek) diametri* dep ataladi'.

Shen'berdin' AB diametri AO ha'm OB radiuslardan du'zilgen. Soni'n' ushi'n shen'ber diametri woni'n' radiusi'nan 2 ma'rte uzi'n boladi'.

6-su'wrette A ha'm B noqatlar shen'berdi yeki bo'lekke aj'rati'p ati'r. Bul bo'leklerdin' ha'r biri *shen'ber dog'asi'*, A ha'm B noqatlar bolsa dog'ani'n' *ushlari'* dep ataladi'.



Sorawlarg'a juwap berin'!

1. Tsirkul ja'rdeminde shen'ber qalay si'zi'ladi'?
2. Qanday figura do'n'gelek dep ataladi'?
3. Shen'ber radiusi' degen ne?
4. Shen'ber diametri radiusi'nan neshe ma'rte u'lken?
5. Shen'ber dog'asi' dep nege aytiladi'?



Sinfda bajariladigan mashqlar

567. Da'pterin'izge O noqati'n belgilen'. Woni' woray yetip tsirkul ja'rdeminde shen'ber si'zi'n'. Si'zg'i'sh penen shen'berdin' radiusi'n wo'lshen'. Bul shen'berdin' diametri nege te?

568. Radiusi' a) 2 sm; b) 4 sm 5 mm bolg'an shen'ber si'zi'n'. Bul shen'berdin' diametri nege ten' boladi'?

569. Worayi' O noqati'nda, radiusi' 8 sm bolg'an do'n'gelek berilgen. Woni'n' shegerasi'nda A noqati', ishki bo'leginde B noqati' ha'm si'rtqi' bo'leginde C noqati' belgilengen. Do'n'gelektin' worayi'nan A noqati'na shekem bolg'an arali'q OA kesindi uzi'nli'g'i' haqqi'nda ne ayti'w mu'mkin? OB kesindi haqqi'nda she? OC kesindi haqqi'nda she?

570. Aralari'ndag'i' arali'q 10 sm bolg'an A ha'm B noqat berilgen. A ha'm B noqatlardi' woray qi'li'p, radiusi' a) 3 sm; b) 5 sm; d) 7 sm bolg'an shen'berler si'zi'lg'an. Bul shen'berler wo'z ara kesilise me?

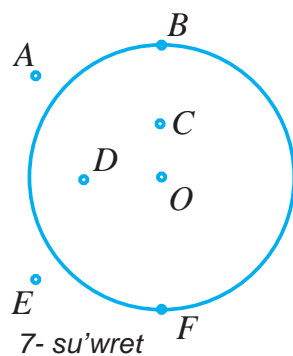

U'yde wori'nlanatug'i'n shi'ng'i'wlar

571. Da'pterin'izge O noqatti' belgilen'. Woni' woray yetip tsirkul ja'rdeminde diametri 12 sm bolg'an shen'ber si'zi'n'.

572. 7-su'wrette su'wretlengen noqatlardi'n' qaysi'lari' shen'berde, qaysi'lari' do'n'gelekte jatadi'?

573. Da'pterin'izge O noqati'n belgilen'. Bir ushi' O noqatta bolg'an uzi'nli'g'i' 3 sm bolg'an – 5 kesindi si'zi'n'. Bul kesindilerdin' yekinshi ushi' shen'berde jatadi'. Bul shen'berdi si'zi'n' ha'm diametrin ani'qlan'.

27- §.

U'LESKER. A'PIWAYI' BO'LSHEKLER HAQQI'NDA TU'SINIK

Ku'ndelikli turmi'si'mi'zda ko'binshe bir pu'tin na'rseni u'leslarga bo'liwge tuwra keledi. Yen' ko'p tarqalg'an u'lesler bul – yari'm ha'm sherek.



1- su'wret

Yari'm killogramm, sherek saat, yari'm litr si'yaqli' so'zlerdi ko'p yesitkensiz. Biraq, matematikada ja'ne basqa da u'lesler bar. Ha'zir usi' u'lesler haqqi'nda aytami'z.

Azada apa nandi' ten'dey to'rt bo'lekke bo'lip, woni'n' bir bo'legin aqli'g'i' Ha'diyshag'a berdi (1-su'wret). Bul ten' bo'lekler *u'lesler* dep ataladi'.

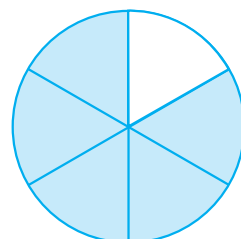

2- su'wret

Bul jag'dayda, Ha'diyshag'a nanni'n' "to'rt u'lestin' birewi", "to'rtten bir u'lesi" tiydi, dep aytami'z.

Yeger nan yeki, u'sh yaki bes ten' bo'leklerge bo'linse, yekiden bir, u'shten bir ha'm besten bir dep atali'wshi' u'lesler payda boladi'.

Segizden bir u'lesi – *yari'm sherek*, to'rtten bir u'lesi – *sherek*, yekiden bir u'lesi – *yari'm* dep te ataladi'.

Do'n'gelek 6 ten' bo'lekke bo'lingen (2-su'wret). Ha'r bir bo'lek woni'n' alti'dan bir u'lesin quraydi'. 2-su'wrette alti' u'lesten besewi boyalg'an. Bul bes u'les – do'n'gelektin' alti'dan bes bo'legi dep ataladi'.

Do'n'gelektin' alti'dan bes bo'legi — $\frac{5}{6}$ ko'riniside an'latiladi' ha'm "alti'dan bes" dep woqi'ladi'.

$\frac{a}{b}$ ko'riniside jazi'w *a'piwayi' bo'lshek* dep ataladi'.

Bo'lshek an'latpasi'ndag'i' *a* sani' bolsa *bo'lshektin' ali'mi*, *b* sani' *bo'lshektin' bo'limi* dep ataladi'. Bo'lshektin' bo'limi asti'nda, ali'mi' bolsa u'stinde jazi'ladi' ha'm wolar bo'lshek si'zi'g'i' menen ajrali'p turadi.

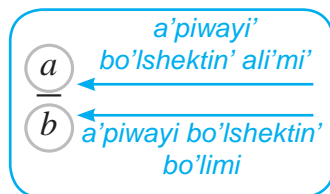

Bo'lshektin' bo'limi – pu'tin neshe u'leske bo'lingenin, ali'mi' bolsa bulu'leslerden neshewi ali'ng'ani'n bildiredi.



Bo'lsheklerdi sanlar nurinda su'wretlew mu'mkin. Ma'selen, $\frac{1}{5}$ bo'lshekti sanlar nuri'nda su'wretleyik. Buni'n' ushi'n sanlar nuri'nda birlik kesindi alami'z ha'm woni' 5 ten' kesindilerga aji'ratami'z (3- su'wret). Wol jag'dayda, *OA* kesindi birlik kesindinin' besten bir bo'legin quraydi' ha'm *A* noqati'ni'n' koordinatasi' $\frac{1}{5}$ ge ten' boladi': $A(\frac{1}{5})$.

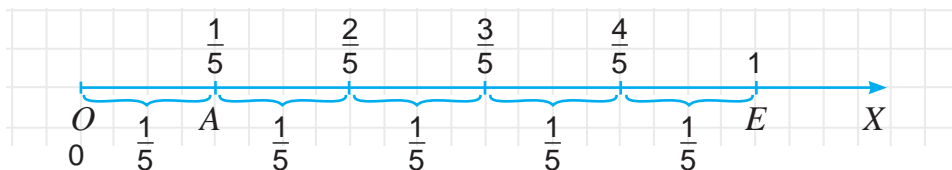

3- su'wret



Qa'legen m sani'ni'n' (shamasi'ni'n') $\frac{a}{b}$ bo'legin tabii'w ushi'n m sani'n b g'a bo'lip a g'a ko'beytiw jetkilikli.

1-mi'sal. Uzi'nli'g'i' 240 m bolg'an si'mni'n' $\frac{5}{6}$ bo'legi qir'qi'p ali'ndi' (4-su'wret). Nyeshe metr si'm qir'qi'p ali'ng'an?

Sheshiliwi. Si'mni'n' $\frac{1}{6}$ u'lesi $240 : 6 = 40$ (m) di quraydi'. Bul u'leslerdin' besewi $40 \cdot 5 = 200$ (m) ge ten' boladi',

Juwap: 200 m si'm qir'qi'p ali'ng'an.

2- mi'sal. Awi'ldan qalag'a shekem bolg'an arali'q 9 km. Ka'mil bul joldi'n' 5 km in basi'p wo'tti (5- su'wret). Ka'mil pu'tkil joldi'n' qansha bo'legin basi'p wo'tken?

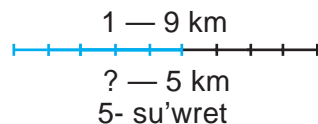

Sheshiliwi. Pu'tkil jol – 9 km. Woni'n' $\frac{1}{9}$ u'lesi yag'ni'y pu'tkil joldi' 9 ten'dey bo'lekke bo'lip, woni'n' bir u'lesin' alsaq 1 km ge ten' boladi'. Wonda 5 km pu'tkil joldi'n' $\frac{5}{9}$ bo'legin payda etedi.

Juwap: Ka'mil pu'tkil joldi'n' $\frac{5}{9}$ bo'legin basi'p wo'tken.



$\frac{a}{b}$ bo'lshek – a sani' b sani'ni'n' qanday bo'legin quraytug'i'ni'n ko'rsetedi.

Wo'lshe'm birliklerinin' kelip shi'g'i'wi' da u'lesler menen baylani'sli'. Uzi'nli'g'i' 1 m bolg'an kesindi 10 ten'dey bo'lekke bo'linse, woni'n' wonnan bir u'lesinen ibarat detsimetr payda boladi'. Demek, $1\text{dm} = \frac{1}{10}\text{m}$, yag'ni'y 1 dm metrdin' wonnan bir u'lesinen ibarat.

Tap usi'g'an uqsas, $1\text{sm} = \frac{1}{100}\text{m}$ ha'm $1\text{mm} = \frac{1}{1000}\text{m}$ yekenligin de ani'qlaw mu'mkin. Solay yetip, bo'lshekler ja'rdeminde kishi wo'lshe'm birlikler u'lken wo'lshe'm birlikleri arqali' an'lati'ladi'.

1 kg = 1000 g bolg'ani' ushi'n, $1\text{g} = \frac{1}{1000}\text{kg}$, yag'ni'y 1 gramm kilogrammi'n' mi'n'nan bir u'lesine ten'.

1 t = 1 000 000 g bolg'ani' ushi'n, $1 \text{ g} = \frac{1}{1\,000\,000} \text{ t}$, yag'ni'y 1 gramm tonnani'n' millionnan bir u'lesin quraydi'i.

Sorawlarg'a juwap berin'.



1. U'les dep nege ayti'ladi'?
2. $\frac{a}{b}$ jazi'wi' nedep ataladi'? a ne dep ataladi'? b she?
3. Bo'lshektin' bo'limi neni an'latadi'? Ali'mi' she?

Klasta wori'nlanatug'i'n shi'ni'g'i'wlar.



574. 6-su'wrette su'wretlengen figuralar ten' bo'leklerge bo'lindi. Bul bo'leklerdin' ha'r biri pu'tin figurani'n' qanday u'lesin quraydi'?

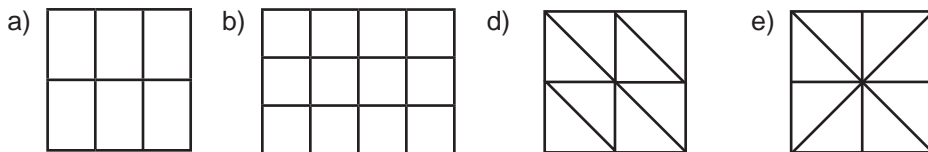

6- su'wret

575. 7- su'wrettegi figuralardi'n' qanday bo'legi boyalg'an, qanday bo'legi boyalmag'an?

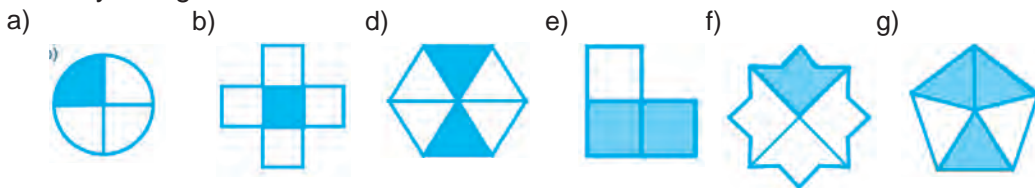

7- su'wret

576. 8- su'wrette figuralardi'n' qanday bo'legi boyalg'an?

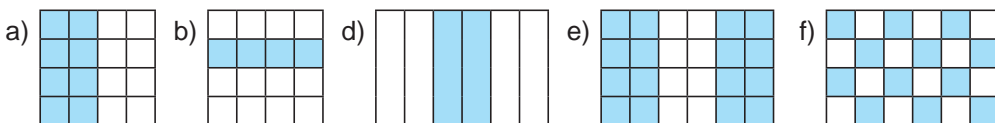

8- su'wret

577. Da'pterin'izge ta'repi 8 ketekshe uzi'nli'g'i'na ten' bolg'an kvadrat si'zi'n'. Woni' to'rt ten'dey bo'lekke bo'lin'. Kvadratti'n' to'rtten bir bo'legin qi'zi'l ren'ge, yari'mi'n ko'k ren'ge boyan'. Kvadratti'n' qanday bo'legi boyalmay qaldi'?

578. Qag'azg'a do'n'gelek si'zi'n' ha'm woni' qir'qi'p ali'n'. Woni' diametri boylap yeki ten'dey bo'lekke bo'lin'. Bul bo'leklerdin' ha'r biri qanday ataladi'? Ha'r bir bo'lekti bu'klep, ja'ne ten' yekige bo'lin'. Payda bolg'an bo'leksheler qanday ataladi'? Bul bo'lekshelerdin' ha'r birin bu'klep, ja'ne ten' yeki bo'lekke bo'lin'. Aqi'ri'nda payda bolg'an kishi bo'leksheler do'n'gelektin' qanday u'lesin quraydi'?

579. a) yari'm; b) sherek; d) yari'm sherek; e) besten bir; f) ju'zden bir; g) ju'zden seksen yeki metrde neshe santimetr bar?
580. Fermer xojali'g'i'nda 270 t paxta wo'niminin' $\frac{7}{9}$ bo'legi terildi. Qansha paxta terilgen?



U'lg'i: Joqari'da ko'rilgen 1-mi'sal.

581. U'leslerdi a'piwayi' bo'lshek ko'rinishinde an'lati'n': a) yekiden bir; a) yekiden bir; b) u'shten bir; d) besten bir; e) segizden u'sh.
582. A'piwayi' bo'lsheklerdi woqi'n'. Bo'lshektin' bo'limin ha'm ali'mi'n ayti'n' ha'm wolardi'n' neni an'lati'wi'n tu'sindirip berin'.

$$\frac{3}{7}; \frac{4}{5}; \frac{5}{6}; \frac{3}{8}; \frac{13}{15}; \frac{5}{9}; \frac{7}{31}; \frac{9}{56}; \frac{47}{112}$$

583. a) 15 tin' $\frac{3}{5}$ bo'legin; b) 219 di'n' $\frac{2}{3}$ bo'legin; d) 1035 ti'n' $\frac{7}{9}$ bo'legin tabi'n'.
584. a) 114 sani' 513 tin'; b) 1012 sani' 6223 tin' qanday qismini tashkil qiladi?
585. Ha'wiz 7 saatta suw menen toladi'. a) 1 saat; b) 3 saat; d) 5 saattan keyin woni'n' qanday bo'legi suw menen toladi'?

U'lg'i: Joqari'da ko'rilgen 3-mi'sal.

586. Kombayn 12 ku'nde ati'zdrag'i' wo'nimdi wori'p aldi'. a) 1 ku'nde; b) 3 ku'nde; d) 5 ku'nde; e) 7 ku'nde ati'zdi'n' qanday bo'legindagi wo'nim ji'ynap ali'ng'an?
587. Da'pterdin' 20 keteginin' uzi'nliig'i'n 1 km dep ali'p, uzi'nli'g'i': a) $\frac{2}{5}$ km; b) $\frac{3}{5}$ km; d) $\frac{3}{4}$ km bolg'an kesindini si'zi'n'.



U'yde wori'nlanatug'i'n shi'ni'g'i'wlar

588. 9- su'wretteg'i figuralardi'n' qanday bo'legi boyalg'an ha'm qanday bo'legi boyalmag'an?

a)

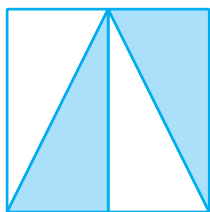

b)

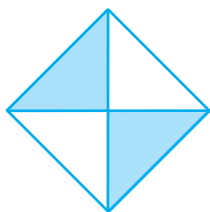

d)

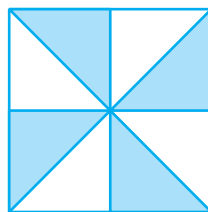

e)

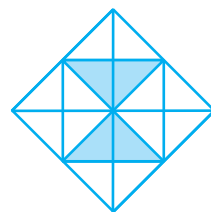

9- su'wret

589. a) Yari'm; b) sherek; d) u'shten bir; e) alpi'stan bir saatta nes he minut bar?
590. Aziza 320 betlik kitapti'n' segizden u'sh bo'legin woqi'di'. Wol kitapti'n' neshe betin woqi'g'an? Kitapti'n' ja'ne neshe beti yele woqi'lmag'an?
591. Azada apa 20 quymaq pisirdi. Aziza quymaqlardi'n' wannan u'sh bo'legin, Nargiza wannan to'rt bo'legin, Dilnaza wannan bir bo'legin jedi. Qansha quymaq qaldi'?



592. 10- su'wretegi tortti'n' massasi' 2450 g boli'p, u su'wrette ko'rsetilgenindey yeki bo'lekke bo'lindi. Tortti'in' ha'r bir bo'leginin' massasi'n ani'qlan'.



10- su'wret

a)



b)



11- su'wret

593. A'piwayi' bo'lshek ko'riniside an'lati'n':

a) u'shten bir; || b)alti'dan bes; || d) besten u'sh; || e) to'rtten bir.

594. Da'pterdin' 20 ketekshe uzi'nli'g'i'n birlik kesindi dep ali'p, uzi'nli'g'i' a) $\frac{3}{10}$;

b) $\frac{7}{10}$; d) $\frac{4}{5}$; e) $\frac{9}{10}$ g'a ten' bolg'an kesindini si'zi'n'.

595. a) 323 tin' $\frac{5}{17}$ bo'legin; b) 1820 nin' $\frac{13}{28}$ bo'legin tabi'n'.

596. a) 31 soni 56 ning; b) 112 soni 259 ning qanday bo'legin quraydi'?

597. 11- su'wrettegi pu'tin tortti'n' massasi' 1260 g bolsa, woni'n' qanshasi' qalg'an?

Qi'ziqli' matematikag'a tiyisli ma'seleler



Jasalma ten'geni ani'qlaw

1. U'sh tiyinnin' birewi jasalma. Wol basqa tiyinlerden jen'il. Tassi'z pa'lle ta'rezide bir ma'rte tarti'w arqali' jasalma tiyindi qalay ani'qlawg'a boladi'? Ta'rezinin' ha'r bir pa'llesine birewden tiyin qoyami'z. U'shinshi tiyindi bir shetke ali'p qoyami'z. Tiyinlerdi tarti'wda 2 jag'day boli'wi' mu'mkin: 1-jag'day. Ta'rezi pa'llelerine qoyil'g'an tiyinler bir qi'yli' awi'rli'qqa iye (a- su'wret); 2-jag'day. Ta'rezinin' bir pa'llesine qoyil'g'an tiyin jen'il (b- su'wret).

a)



b)



1-jag'dayda qaysi' tiyin jasalma? 2-jag'dayda she?

2. 9 tiyinnin' birewi jasalma. Wol basqa tiyinlerden jen'il. Tassi'z pa'lleli ta'rezide yeki ma'rte tarti'w arqali' jasalma tiyindi qalay ani'qlawg'a boladi'?
3. 27 tiyinnin' birewi jasalma. Wol basqa tiyinlerden jen'il. Tassi'z pa'lleli ta'rezide yen' keminde neshe ma'rte tarti'w arqali' jasalma tiyindi ani'qlawg'a boladi'?

28- §

BO'LSHEKLERDI SALI'STI'RI'W

Ja'ne sol aldi'ng'i' sabaqta ko'rilgen ma'selege qaytami'z (1- su'wret). yendi, Azada apa nandi' ten'dey to'rt bo'lekke bo'lip, aqli'g'i' Ha'diyshege yekewin bergen bolsi'n. Biraq, bul yeki bo'lek birgelikte nanni'n' yari'mi'n quraydi'.

Demek, nanni'n' $\frac{2}{4}$ ha'm $\frac{1}{2}$ bo'legi wo'z ara ten' boladi'. Bul jag'dayda $\frac{2}{4}$ ha'm $\frac{1}{2}$ bo'lsheklar ten' delinedi ha'm $\frac{2}{4} = \frac{1}{2}$ tu'rinde jazi'ladi' (2- su'wret).



1- su'wret



2- su'wret



Yeki ten' bo'lsheklar bir bo'lshek sani'ni'n' ha'r qi'yili' an'latpasi'nan ibarat.

Pa'tir 5 ten' bo'lekke bo'lindi. Bul u'leslerdin' 2 yewi bir ta'relrag'a, qalg'an u'shewi yekinshi ta'relrag'a sali'ndi' (3- su'wret). Bizge belgili, yeki u'les pa'tirdin' $\frac{3}{5}$ bo'legin, u'sh u'les pa'tirdin' $\frac{2}{5}$ bo'legin quraydi'.

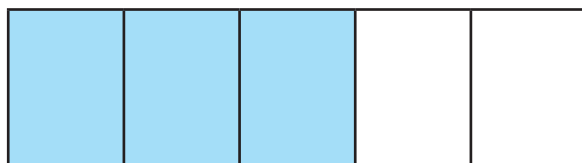

3- su'wret

Ko'rip turg'ani'n'i'zday, tuwri' to'rtmu'yeshliktin' boyalg'an bo'legi boyalmag'an bo'leginen u'lken.

Demek, $\frac{3}{5} > \frac{2}{5}$ boladi'.



Birdey bo'limli yeki bo'lshekten qaysi'si'ni'n' ali'mi' kishi (u'lken) bolsa, sol bo'lshek kishi (u'lken) boladi'.

Sanlar nuri'nda yeki bo'lsheklar qaysi' biri yekinshisine qarag'anda shepte (on'da) jatqan bolsa usi' bo'lshek kishi (u'lken) boladi'.

Haqi'yqattan da, 4- su'wrette $A(\frac{2}{5})$ noqati' $B(\frac{3}{5})$ noqati'nan shepte jatadi'.

Soni'n' ushi'n $\frac{2}{5} < \frac{3}{5}$.

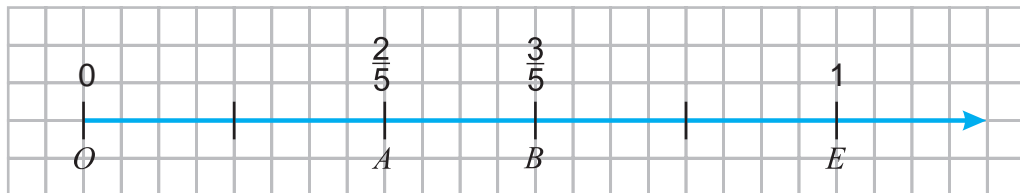

1-mi'sal. Poezd 420 km jol ju'rip, barli'q joldi'n $\frac{2}{3}$ bo'legin basi'p wo'tti. Barli'q jol neshe km?

Sheshiliwi. Sha'rt boyi'nsha, 420 km barli'q joldi'n $\frac{2}{3}$ bo'legi yag'ni'y yeki $\frac{1}{3}$ bo'legin quraydi'.

Demek, barli'q joldi'n $\frac{1}{3}$ bo'legi $420 : 2 = 210$ (km) ge ten' boladi'.

Wonda barli'q jol $210 \cdot 3 = 630$ (km) ge ten' boladi'.

Juwap: Barli'q jol 630 km.

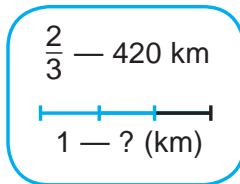

Sanni'n $\frac{a}{b}$ bo'legi m ge ten' bolsa, bul sanni'n wo'zin tabi'w ushi'n m di' b g'a ko'beytip, a g'a bo'liw jetkilikli.



Sorawlarg'a juwap berin'



1. Ten' bo'lshekler sanlar nuri'nda qanday su'wretlenedi?
2. Bo'limi birdey bolg'an bo'lsheklerden qaysi' biri u'lken boladi'?
3. Sanlar nuri'nda yeki bo'lshektin' qaysi' biri u'lken ya'ki kishi yekenligin qalay ani'qlawg'a boladi'?

Klasta wori'nlanatug'i'n shi'ni'g'i'wlar



598. To'mendegi ten'likti su'wret ja'rdeminde tu'sindirir'n:

a) $\frac{1}{4} = \frac{2}{8}$;



b) $\frac{1}{3} = \frac{2}{6}$.



599. Da'pterin'izge 12 ketekshe uzi'nli'g'i'na ten' bolg'an kesindi si'zi'n'. Usi' kesindiden paydalani'p, to'mendegi ten'likti ta'riplen':

a) $\frac{2}{3} = \frac{8}{12}$;

b) $\frac{5}{6} = \frac{10}{12}$.

600. Da'pterdan 12 ketekshe uzi'nli'g'i'na ten' bolg'an birlik kesindi ali'p sanlar nuri'nda koordinatalari' $\frac{1}{4}$, $\frac{2}{3}$, $\frac{3}{4}$, $\frac{3}{12}$, $\frac{4}{6}$, $\frac{8}{12}$, $\frac{3}{6}$, $\frac{1}{2}$ bolg'an noqatlardi' belgilen'. Wolar arasi'ndag'i' ten' bo'lsheklerdi' ani'qlan'.

601. Da'pterden 18 ketekshe uzi'nli'g'i'na ten' bolg'an birlik kesindi ali'p, sanlar nuri'nda koordinatalari' $\frac{1}{2}, \frac{2}{3}, \frac{5}{6}, \frac{4}{9}, \frac{1}{6}, \frac{7}{9}$ bolg'an noqatlardi' belgilen'. Bul noqatlardan qaysi' biri sanlar ko'sherinde yen' shepte, qaysi' biri yen' won'da jaylasqanli'g'i'n ani'qlan'.

602. To'mendegi bo'lsheklerdi: a) kemeyiw; b) wo'siw ta'rtbinde jaylasti'ri'n'.

$$\frac{5}{9}; \frac{4}{9}; \frac{1}{9}; \frac{7}{9}; \frac{8}{9}; \frac{6}{9}; \frac{2}{9}.$$



603. Juldi'zsha worni'na tiyisli u'lken (>) yamasa kishi (<) belgisin qoyi'n':

a) $\frac{5}{9} * \frac{4}{9}$; || b) $\frac{1}{8} * \frac{7}{8}$; || d) $\frac{2}{5} * \frac{3}{5}$; || e) $\frac{2}{7} * \frac{6}{7}$.

601. Qaysi' bo'lshek kishi? Ne ushi'n?

a) $\frac{11}{19}$ yamasa $\frac{7}{19}$; || b) $\frac{17}{38}$ yamasa $\frac{23}{38}$;
d) $\frac{4}{51}$ yamasa $\frac{23}{51}$; || e) $\frac{23}{100}$ yamasa $\frac{67}{100}$.

605. a) $\frac{3}{5}$ bo'legi 315 ke; b) $\frac{3}{7}$ bo'legi 219 g'a; d) $\frac{5}{17}$ bo'legi 15 ke ten' bolg'an sandi' tabi'n'.

U'lgi: Joqari'da ko'rilgen 1-mi'sal.

606. *b* ni'n' qanday ma'nislerinde $\frac{5}{12}$ bo'lshek $\frac{b}{12}$ bo'lshekten u'lken boladi'? Bunday bo'lsheklerdin' barli'g'i'n jazi'n'.

607. *c* ni'n' qanday ma'nislerinde $\frac{c}{17}$ bo'lshek $\frac{6}{17}$ bo'lshekten u'lken, biraq $\frac{13}{17}$ bo'lshekten kishi boladi'? Bunday bo'lsheklerdin' barli'g'i'n jazi'n'.

608. Jumi'sshi' 24 detal tayarladi'. Bul ku'nlik rejeninin' $\frac{3}{8}$ bo'legin quraydi'. Jumi'sshi' bir ku'nde reje boyi'nsha neshe detal tayarlawi' kerek?

U'lgi: Joqari'da ko'rilgen 1-mi'sal.

609. Da'pterin'izge sanlar nuri'n si'zi'n'. Wonda 18 ketekshe uzi'nli'g'i'na ten' bolg'an birlikkesindi ali'p, $A(\frac{2}{9})$ ha'm $B(\frac{4}{18})$ noqatlari'n belgilen' ha'm juwmaq shi'g'ari'n'.



U'yde wori'nlantug'i'n shi'ni'g'i'wlar

610. Dapterin'izge sanlar nuri'n si'zi'n'. Wonda 18 ketekshe uzi'nli'g'i'na ten' bolg'an birlik kesindi ali'p, koordinatalari' $\frac{2}{3}, \frac{3}{18}, \frac{4}{6}, \frac{6}{18}, \frac{1}{6}, \frac{1}{3}, \frac{3}{9}$ bolg'an noqatlardi' belgilen'. Wolar arasi'nan ten' bo'lsheklerdi ani'qlan'.

611. 606- ma'selede berilgen bo'lsheklarda a) kemeyiw; b) wo'siw ta'rtibinde jaylasti'ri'n'.

612. Juldi'zsha worni'na tiyisli u'lken (>) yamasa kishi (<) belgisin qoyi'n':

a) $\frac{5}{11} * \frac{8}{11}$; || b) $\frac{9}{13} * \frac{7}{13}$; || d) $\frac{7}{15} * \frac{2}{15}$; || e) $\frac{23}{31} * \frac{6}{31}$.



613. 4- su'wrette ko'rsetilgen si'zi'lmalardi'n' qanday bo'legi boyalg'an?

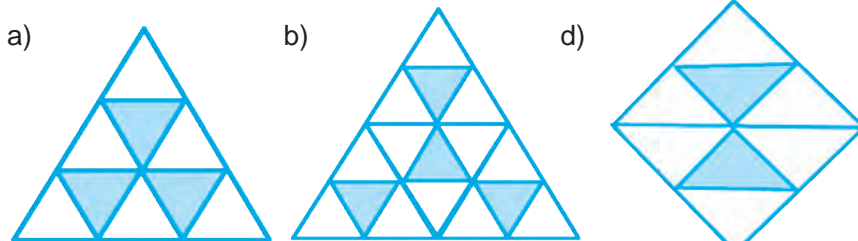

4- su'wret

614. Qaysi' bo'lshek u'lken? Ne ushi'n?

a) $\frac{8}{11}$ yaki $\frac{7}{11}$; || b) $\frac{17}{28}$ yaki $\frac{13}{28}$; || d) $\frac{237}{1000}$ yaki $\frac{367}{1000}$.

615. a) $\frac{7}{9}$ bo'legi 21 ge; b) $\frac{5}{13}$ bo'legi 65 ke ten' bolg'an sandi' tabi'n'.

616. c ni'n' qanday ma'nislarinde $\frac{c}{13}$ bo'lshek $\frac{4}{13}$ bo'lshekdan u'lken, biraq $\frac{10}{13}$ bo'lshekten kishi boladi'? Bunday bo'lsheklerdin' barli'g'i'n' jazii'n'.

Qi'ziqli' matematikag'a tiyisli ma'seleler



Sati'wshi' pi'shaq penen to'rt ma'rte kesip si'rdi 8 ten' bo'lekke bo'ldi. Buni' wol qanday a'melge asi'rg'an?

Matematika tarixiga oid lavhalar



A'yyemde jerdi wo'lshew isleri a'hmiyetli wori'nda turg'an. Jerdi wo'lshewge bolg'an insanni'n' mu'tajlikleri sebepli matematikani'n' a'jayi'p bo'limi-geometriya pa'ni payda bolg'an. "Geometriya" atamasi'ni'n' "jer wo'lsheyman" degen so'zlik ma'nisi de buni' tasti'yi'qlap turi'pti'.

Matematika, tiykari'nan geometriya iliminen jaqsi' xabardar bolg'an, ulli' jerlesimiz Ahmad al-Ferg'aniy Mi'srda Nil da'ryasi' suwi'ni'n' i'yi'mli'li'g'i'n' ha'm teren'ligin wo'lsheyug'i'n' imarat quri'li'si'na basshi'li'q qi'lg'an. Bul imarat ha'zirde de Qahi'ra qalasi'nda jaqsi' saqlani'p qalg'an.

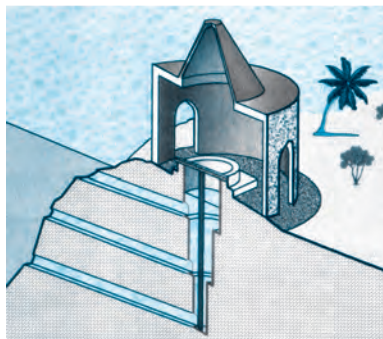

29- §

DURIS HA'M NADURIS BO'LSHEKLER

Shokolad plitkasi' 12 bo'lekten (won yekiden bir u'lesten) ibarat (1.a-su'wret). Woni'n' 5 bo'legi si'ndi'ri'p ali'ni'p, tarelkag'a qoyi'ldi'. Na'tiyjede tarelkag'a shokoladi'n' $\frac{5}{12}$ bo'legi qoyi'lg'an boladi' (1.b-su'wret).

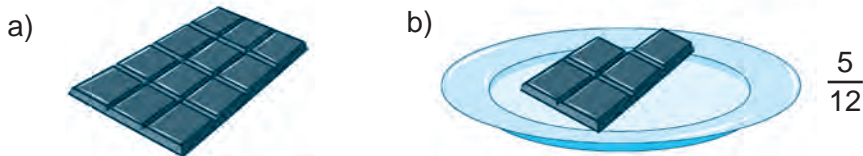

1- su'wret

Yeger ta'relkag'a 12 bo'lektin' ha'mmesi qoyi'lg'anda, ta'relkada shokoladi'n' $\frac{12}{12}$ bo'legi qoyi'lg'an bolar yedi (2.b-su'wret).

Demak, $\frac{12}{12} = 1$ ekan.

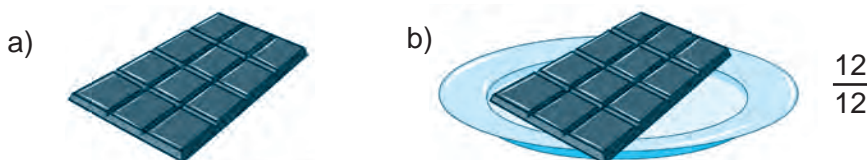

2- su'wret

Yendi 2 shokolad plitkasi'n alamiz (3.a-su'wret). Tarelkag'a 17 shokolad bo'legin qo'yami'z. Wonda tarelkag'a shokoladi'n' $\frac{17}{12}$ bo'legi qoyi'lg'an boladi' (3.b-rasm).

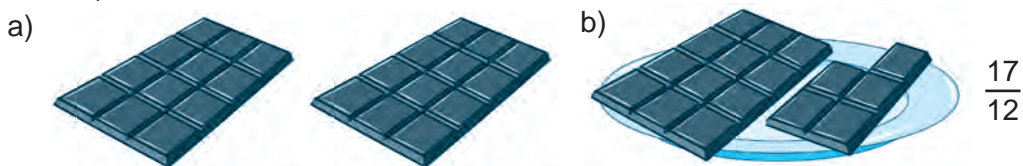

3- su'wret

$\frac{5}{12}$ bo'lshektin' ali'mi' bo'liminen kishi.

Ali'mi' bo'liminen u'lken bo'lshekler *duri's bo'lshekler* dep ataladi'.

$\frac{12}{12}$ bo'lshektin' ali'mi' bo'limine ten', $\frac{17}{12}$ bo'lshektin' bolsa ali'mi' bo'liminen u'lken.

Ali'mi' bo'liminen u'lken yamasa ten' bolg'an bo'lshekler *naduri's bo'lshekler* dep ataladi'.



Duri's bo'lshekler 1 den kishi boladi'. Naduri's bo'lshekler bolsa 1 den u'lken yamasa 1 ge ten' boladi'.

Sorawlarg'a juwap berin'



1. Qanday bo'lshek duri's bo'lshek dep atladi'?
2. Bo'lshektin' naduri's bo'lshek yekenligin qanday ani'qlawg'a boladi'?
3. Qanday bo'lshekler 1 den kishi boladi'?
4. Naduri's bo'lshek 1 den kishi boli'wi' mu'mkin be?

Klasta wori'nlanatug'i'n shi'ni'g'i'wlar



- 617.** To'medegi bo'lsheklerden qaysi' biri duri's, qaysi' biri naduri's bo'lshek yekenligin ani'qlan':

$$\frac{1}{4}; \frac{5}{3}; \frac{3}{4}; \frac{17}{12}; \frac{4}{6}; \frac{8}{8}; \frac{23}{22}; \frac{209}{999}.$$

- 618.** To'mendegi bo'lsheklerden qaysi' biri: a) 1 den u'lken; b) 1 ge ten'; d) 1 den kishi?

$$\frac{5}{9}; \frac{4}{3}; \frac{8}{13}; \frac{17}{9}; \frac{81}{79}; \frac{7}{7}; \frac{2}{9}; \frac{51}{90}; \frac{42}{42}; \frac{1}{19}.$$

- 619.** Bo'limi 11 bolg'an a) 3 duri's; b) 3 naduri's bo'lshek jaz i'n'.

- 620.** Da'pterin'izge sanlar nuri'n si'zi'n'. Wonda 8 ketekshe uzi'nli'g'i'na ten' bolg'an birlik kesindi ali'p, koordinatalari $\frac{1}{8}, \frac{4}{8}, \frac{5}{8}, \frac{3}{8}, \frac{9}{8}, \frac{11}{8}, \frac{8}{8}, \frac{13}{8}$ bolg'an noqatlardi' belgilen'. Bul bo'lsheklerdin' qaysi'lari': a) 1 den u'lken; b) 1 ge ten'; d) 1 den kishi?

- 621.** 4- su'wretke qarap: a) EM kesindi KD kesindinin'; b) KD kesindi EM kesindinin' qanday bo'legin quraytug'i'ni'n tabi'n'.

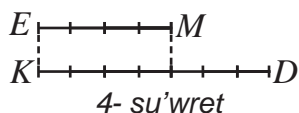

- 622.** a ni'n' qanday ma'nislerinde: a) $\frac{a}{13}$ duri's bo'lshek; b) $\frac{15}{a}$ naduri's bo'lshek boladi'?

- 623.** a) Yari'mi' 12 qa; b) shereki 19 g'a; d) u'shten yeki bo'legi 24 ke ten' bolg'an sandi' tabi'n'.



- 624.** 1 kg tonnani'n' qanday bo'legin quraydi'? 1 centner she?

- 625.** Minut saatti'n' qanday bo'legin quraydi'? 19 minut she? 30 minut she? 48 minut she?

- 626.** a) $\frac{1}{4}$; b) $\frac{3}{4}$; d) $\frac{3}{10}$; e) $\frac{13}{10}$ tonnada neshe kg bar?

- 627.** a) $\frac{2}{5}$; b) $\frac{3}{5}$; d) $\frac{7}{10}$; e) $\frac{9}{2}$ saatta neshe minut bar?

- 628.** 1 kg boyaw menen 7 m² maydandi' boyaw mu'mkin 4 m², 9 m², 18 m² maydandi' boyaw ushi'n qansha boyaw kerek boladi'?

629. a) $\frac{1}{3}$ bo'legi 18 ge; b) $\frac{1}{6}$ bo'legi 12 ge; d) $\frac{1}{12}$ bo'legi 4 ke ten' bolg'an sandi' tabi'n'.
630. Sayaxatshi' 24 km joldi' 2 ku'nde basi'p wo'tiwi kerek yedi. Biraq, wol birinshi ku'nipu'tkil joldi'n' $\frac{7}{12}$ bo'legin basi'p wo'tti. Sayaxatshi' yekinshi ku'ni ja'ne neshe km jol basi'wi' kerek?



U'yde wori'nlantug'i'n shi'ni'g'i'wlar

631. Ali'mi' 7 bolg'an a) 3 duri's; b) 3 naduri's bo'lshek jazi'n'.
632. Shaxmat taxtasi'ni'n' qanday bo'legi qara ren'ge boyalg'an?
633. 5- su'wretke qarap: a) AB kesindi CD kesindinin'; b) CD kesindi AB kesindinin' qanday bo'legin quraytug'i'ni'n tabi'n'.

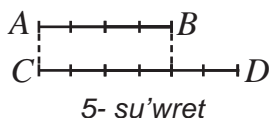

634. a ni'n' qanday ma'nislerinde: a) $\frac{a}{8}$ duri's bo'lshek; b) $\frac{21}{a}$ naduri's bo'lshek.

635. a) $\frac{2}{3}$ s; b) $\frac{3}{12}$; s d) $\frac{24}{15}$ saatta neshe minut bar?
636. Azang'i' saat 7 de sutkani'n' qanday bo'legi wo'tken boladi'?
637. a) $\frac{2}{3}$ bo'legi 24 ga; b) $\frac{3}{5}$ bo'legi 9 g'a ten' bolg'an sandi' tabi'n'.
638. Sayaxatshi' 27 km jol ju'rди. Bul pu'tkil joldi'n' $\frac{3}{5}$ bo'legin quraydi'. Sayaxatshi' ma'nzilge jetip bari'wi' ushi'n ja'ne neshe km jol ju'riwi kerek?



Bilimin'izdi si'nap ko'rin'!

7-qadag'alaw jumi's u'lgisi

- Da'pterdin' 8 ketekshe uzi'nli'g'i'n birlik kesindi dep ali'p, sanlar nuri'nda $A(\frac{3}{8})$, $B(\frac{1}{2})$, $C(\frac{7}{8})$, $D(\frac{1}{4})$, $E(\frac{11}{8})$ noqatlardi' belgilen'.
- Sanlardi' sali'sti'ri'n': a) $\frac{5}{13}$ ha'm $\frac{7}{13}$; b) 1 ha'm $\frac{7}{6}$; d) $\frac{11}{15}$ ha'm $\frac{8}{15}$; e) $\frac{8}{9}$ ha'm $\frac{16}{18}$.
- 30 di'n' $\frac{3}{5}$ bo'legin 14 tin' $\frac{2}{7}$ bo'legine qosi'n'.
- a) 9 sm^2 detsimetr kvadratti'n'; b) 17 dm^3 metr kubti'n' qanday ma'nisin quraydi'; d) 13 kg centnerdin' qanday bo'legin quraydi'?
- Tuwri'mu'yeshliktin' yeni 48 sm boli'p, wol perimetrinin' $\frac{3}{16}$ bo'legin quraydi'. Tuwri'mu'yeshliktin' uzi'nli'g'i'n tabi'n'.

30- §

BO'LI'MLERI' BI'RDEY BOLG'AN BO'LSHEKLERDI' QOSIW

Bo'lshek sanlardi' natural sanlar si'yaqli' qosi'w, ali'w, ko'beytiw ha'm bo'liw mu'mkin. 6-klasta bo'lshekler u'stinde qa'legen a'mellerdi wori'nlawdi' u'yrenesiz. Ha'zirshe birdey bo'limge iye bo'lsheklerdi qosi'w ha'm ali'w u'stinde to'qtalami'z.

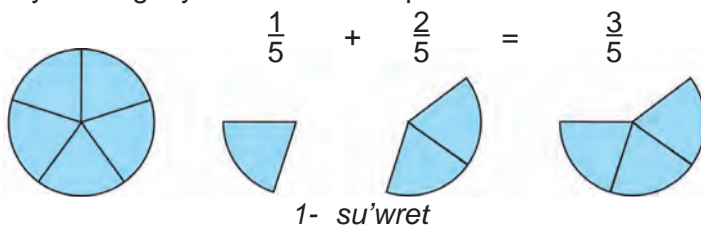

1- su'wrette do'n'gelek 5 ten'dey bo'lekke bo'lingen. Do'n'gelek bo'leklerinin' biri ($\frac{1}{5}$ bo'legi) ali'ni'p, wog'an bul bo'leklerdin' yekewi ($\frac{2}{5}$ bo'legi) qo'si'lsa, do'n'gelektin' u'sh bo'legi ($\frac{3}{5}$ bo'legi) payda boladi'. Bul to'mendegishe jazi'ladi': $\frac{1}{5} + \frac{2}{5} = \frac{1+2}{5} = \frac{3}{5}$.

Birdey bo'limge iye bo'lsheklerdi qosi'wda, qosi'li'wshi'lardi'n' ali'mlari' qosi'li'p, na'tiyjede qosi'ndi'ni'n' ali'mi'na, bo'limin bolsa wo'zgerissiz qaldi'ri'p, qosi'ndi'ni'n' bo'limine jazi'ladi'.



Bul ni'zam ha'ripler ja'rdeminde to'mendegishe jazi'ladi': $\frac{a}{b} + \frac{c}{b} = \frac{a+c}{b}$.

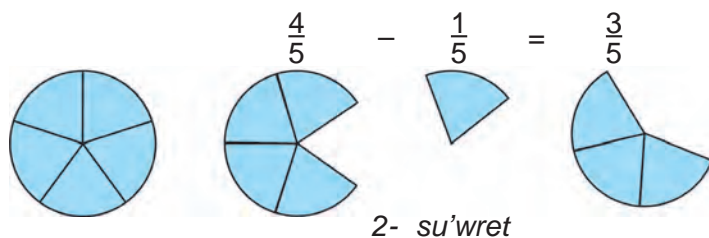

2-su'wrette do'n'gelek bo'leklerinin' to'rtewi ($\frac{4}{5}$ bo'legi) ali'ni'p, wonnan bul bo'leklerdin' biri ($\frac{1}{5}$ bo'legi) ali'nsa, do'n'gelektin' u'sh bo'legi ($\frac{3}{5}$ bo'legi) qaladi':

$$\frac{4}{5} - \frac{1}{5} = \frac{4-1}{5} = \frac{3}{5}$$

Birdey bo'limge iye bo'lsheklerdi ali'wda, kemeyiwshinin' ali'mi'nan ali'ni'wshi'ni'n' ali'mi' ali'nadi', na'tiyjeni ayi'rmani'n' ali'mi'na, bo'limi bolsa wo'zgerissiz qaldi'ri'li'p, ayi'rmani'n' bo'limine jazi'ladi'.



Bul ni'zam ha'ripler ja'rdeminde to'mendegishe jazi'ladi': $\frac{a}{b} - \frac{c}{b} = \frac{a-c}{b}$.

Bo'lsheklerdi qosi'w ha'm ali'wdi' sanlar nuri' ja'rdeminde de tu'sindiriy mu'mkin.

2- su'wrette OA ha'm AB kesindilerdi san nuri'nda qosi'w su'wretlengen.

Su'wret boyi'nsha OA kesindinin' uzi'nli'g'i' $\frac{3}{7}$ ga, AB kesindi uzi'nli'g'i' $\frac{2}{7}$ ge ten'. OB kesindinin' uzi'nli'g'i' bolsa $\frac{5}{7}$ ge ten'. Bizge belgili, $OB = OA + AB$.

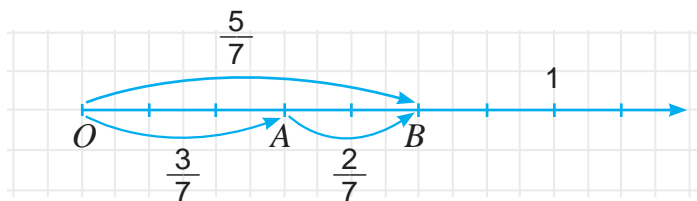

2- su'wret

Demek, $\frac{5}{7}$ bo'lshek $\frac{3}{7}$ ha'm $\frac{2}{7}$ bo'lsheklerinin' qosi'ndi'si'nan ibarat boladi' ha'm bul $\frac{3}{7} + \frac{2}{7} = \frac{5}{7}$ ko'riniside jazi'ladi'.

$$OA = OB - AB \text{ ten'likten } \frac{5}{7} - \frac{2}{7} = \frac{3}{7},$$

$$AB = OB - OA \text{ ten'likten bolsa } \frac{5}{7} - \frac{3}{7} = \frac{2}{7} \text{ ge iye bolami'z.}$$

1- mi'sal. Bo'lsheklerdi qosi'n':

$$a) \frac{3}{10} + \frac{4}{10} = \frac{3+4}{10} = \frac{7}{10}$$

$$b) \frac{5}{11} + \frac{2}{11} + \frac{3}{11} = \frac{5+2+3}{11} = \frac{10}{11}.$$

2- mi'sal. Bo'lsheklerdi ali'n':

$$a) \frac{5}{9} - \frac{1}{9} = \frac{5-1}{9} = \frac{4}{9}$$

$$b) \frac{9}{17} - \frac{4}{17} = \frac{9-4}{17} = \frac{5}{17}.$$



Sorawlarg'a juwap berin'

1. Birdey bo'limge iye bo'lshekler qalay qosi'ladi'?
2. Birdey bo'limge iye bo'lshekler qalay ali'nadi'?
3. Birdey bo'limge iye bo'lsheklerdi qosi'wdi' sanlar nuri'nda tu'sindirin'.



Klasta wori'nlanatug'i'n shi'ni'g'i'wlar

639. Bo'lshekler u'stinde a'mellerdi wori'nlan':

$$a) \frac{3}{5} + \frac{4}{5}; \quad b) \frac{3}{12} + \frac{4}{12}; \quad d) \frac{13}{25} + \frac{14}{25}; \quad e) \frac{8}{19} + \frac{11}{19} + \frac{1}{19};$$

$$f) \frac{5}{7} - \frac{3}{7}; \quad g) \frac{9}{13} - \frac{7}{13}; \quad h) \frac{46}{125} + \frac{34}{125}; \quad i) \frac{118}{219} + \frac{110}{219}.$$

640. Massasi $\frac{4}{15}$ kg bolg'an pomidorg'a, $\frac{7}{15}$ kg qi'yar ha'm $\frac{2}{15}$ kg pi'yaz qosi'p salat tayarladi'. Salatti'n' massasi'n tabi'n'?

641. Jumi'sshi'llar birinshi ku'ni buyi'rtpani'n $\frac{4}{9}$ bo'legin, yekinshi ku'ni bolsa $\frac{3}{9}$ bo'legin wori'nлади'. Yeki ku'nde jumi'sshi'lar buyi'rtpani'n' qansha bo'legin wori'nлади'?

642. Begzad puli'ni'n $\frac{4}{7}$ bo'legine kitap ha'm $\frac{2}{7}$ bo'legine da'pter sati'p aldı'. Begzadta puli'ni'n' qansha bo'legi qaldi'?

643. I'di'sta $\frac{5}{7}$ l yeritpe bar yedi. $\frac{4}{7}$ l yeritpe isletilgennen son', wog'an ja'ne $\frac{3}{7}$ litr yeritpe quyi'ldi'. Idi'sta qansha yeritpe qaldi'?



644. Bo'lshekler u'stinde a'mellerdi wori'nlan':

$$\begin{array}{llll} \text{a) } \frac{2}{9} + \frac{5}{9}; & \text{b) } \frac{13}{17} - \frac{2}{17}; & \text{d) } \frac{5}{9} - \frac{1}{9}; & \text{e) } \frac{15}{39} + \frac{13}{39}; \\ \text{f) } \frac{1}{7} + \frac{5}{7}; & \text{g) } \frac{27}{100} + \frac{43}{100}; & \text{h) } \frac{100}{101} - \frac{91}{101}; & \text{i) } \frac{657}{1143} + \frac{342}{1143}. \end{array}$$

645. a ni'n' qanday ma'nisinde ten'lik wori'nli' boladi'??

$$\text{a) } \frac{a}{9} + \frac{5}{9} = \frac{10}{9}; \quad \text{b) } \frac{a}{17} + \frac{2}{17} = \frac{14}{17}; \quad \text{d) } \frac{a}{9} - \frac{1}{9} = \frac{4}{9}; \quad \text{e) } \frac{15}{39} + \frac{a}{39} = \frac{24}{39}.$$

646. Yeger $b = \frac{5}{14}; \frac{9}{14}; \frac{13}{14}$ bolsa, $b - \frac{2}{14}$ an'latpani'n' ma'nisin tabi'n'.

647. Malika 14 ku'nlik qi'sqi' dem ali'sti'n' 5 ku'nin kempir apasi'ni'n' u'yinde, qalg'an bo'legin u'yinde wo'tkerdi. Wol dem ali'si'ni'n' qansha bo'legin u'yinde wo'tkergen?

648. Yeger 1 kg pistenin' $\frac{1}{5}$ bo'legin may qurasa, 20 kg piste mayi'n ali'w ushi'n neshe kg piste kerek boladi'?

649. Agar a) $a = \frac{3}{13}; b = \frac{7}{13}; c = \frac{5}{13};$ || b) $a = \frac{5}{21}; b = \frac{15}{21}; c = \frac{9}{21};$

d) $a = \frac{23}{75}; b = \frac{34}{75}; c = \frac{41}{75}$ bolsa, $a + b - c$ an'latpasi'ni'n' ma'nisin tabi'n'.



650. 24 woqi'wshi'ni'n' 13 i u'lgili ha'm 8 i jaqsi' bahalarg'a woqi'ydi'. Klastag'i' u'lgili ha'm jaqsi' bahalarg'a woqi'ytug'i'n woqi'wshi'lardi'n' ja'mi woqi'wshi'lar sani'na qatnasi'ni'n' u'lesin tabi'n'?

651. 200 ga yegin maydani'ni'n' $\frac{6}{10}$ bo'legine kartoshka ha'm $\frac{3}{10}$ bo'legine piyaz yegildi. Neshe gektar yegin maydani' bos qaldi'?

652. A'mellerdi wori'nlan':

$$\begin{array}{lll} \text{a) } \frac{19}{21} - \frac{16}{21} + \frac{7}{21}; & \text{b) } \frac{9}{11} + \frac{8}{11} - \frac{10}{11}; & \text{d) } \frac{100}{101} + \frac{1}{101} - \frac{99}{101}; \\ \text{e) } \frac{19}{34} - \left(\frac{21}{34} - \frac{7}{34} \right); & \text{f) } \frac{39}{45} - \left(\frac{43}{45} - \frac{41}{45} \right); & \text{g) } \frac{198}{233} - \left(\frac{101}{233} + \frac{87}{233} \right). \end{array}$$



653. Yeger $\frac{3}{14} + \frac{8}{14} = \frac{11}{14}$ yekenligi belgili bolsa, to'mendegi ten'leminin' sheshimin tabi'n':

$$\text{a) } x - \frac{3}{14} = \frac{8}{14}; \quad \text{b) } \frac{11}{14} - y = \frac{8}{14}; \quad \text{d) } z + \frac{3}{14} = \frac{11}{14}; \quad \text{e) } \frac{11}{14} - p = \frac{3}{14}.$$

654. Ten'lemeni sheshin':

$$\text{a) } x - \frac{3}{34} = \frac{5}{34}; \quad \text{b) } \frac{36}{77} - y = \frac{19}{77}; \quad \text{d) } z + \frac{15}{24} = \frac{23}{24}; \quad \text{e) } \frac{14}{87} + p = \frac{80}{87}.$$

655. Bag'tan ja'mi 3 ts 60 kg miywe terildi. Miywelerdin' $\frac{7}{12}$ bo'legin alma, $\frac{4}{12}$ almurt ha'm qalg'ani'n ayba quraydi'. Terilgen almalar almurttan neshe kg ko'p?

656. Kitapti'n' birinshi bo'limi kitapti'n' $\frac{5}{13}$ bo'legin, yekinshi bo'limi bolsa woni'n' $\frac{2}{13}$ bo'legin quraydi'. Yeger birinshi bo'lim yekinshi bo'limnen 12 bet ko'p bolsa, kitap neshe betten ibarat?

657. Ten'lemeni sheshin':

$$\text{a) } \frac{17}{35} - x = \frac{8}{35} + \frac{3}{35}; \quad \text{b) } y - \frac{17}{21} = \frac{19}{21} - \frac{16}{21}; \quad \text{d) } z + \frac{35}{49} = \frac{41}{49} + \frac{39}{49}.$$



U'yde wori'nlantug'i'n shi'ni'g'i'wlar

658. Yesaplan':

$$\begin{array}{llll} \text{a) } \frac{1}{8} + \frac{5}{8}; & \text{b) } \frac{5}{9} + \frac{3}{9}; & \text{d) } \frac{13}{21} + \frac{4}{21}; & \text{e) } \frac{8}{27} + \frac{15}{27} + \frac{13}{27}; \\ \text{f) } \frac{5}{12} - \frac{1}{12}; & \text{g) } \frac{11}{23} - \frac{7}{23}; & \text{h) } \frac{360}{500} - \frac{234}{500}; & \text{i) } \frac{68}{100} - \frac{54}{100}. \end{array}$$

659. Jasi'l boyaw payda yetiw ushi'n massasi' $\frac{7}{12}$ kg bolg'an sari' boyawg'a massasi' $\frac{4}{12}$ kg bolg'an ko'k boyaw qosi'p aralasti'ri'ladi'. Jasi'l boyawdi'n' massasi'n tabi'n'.

660. Yegilgen 150 pomidor na'linin' 120 si' wo'sip shi'qti'. Na'ldin' qanday bo'legi wo'sip shi'qpag'an?

661. Qaymaqti'n' $\frac{1}{5}$ bo'legin may quraydi'. 20 kg qaymaqta qansha may bar?



662. Yeki ku'nde bag'da yeriktin' $\frac{11}{12}$ bo'legi terildi. yeger birinshi ku'ni yeriktin' $\frac{5}{12}$ bo'legi terilgen bolsa, yekinshi ku'ni ja'mi qansha bo'legi terilgen?

663. Bo'lshekler u'stinde a'meller wori'nlan':

a) $\frac{3}{7} + \frac{4}{7}$; b) $\frac{19}{27} + \frac{2}{27}$; d) $\frac{157}{439} + \frac{213}{439}$;
 e) $\frac{113}{117} - \frac{75}{117}$; f) $\frac{234}{2161} - \frac{227}{2161}$; g) $\frac{1200}{1501} - \frac{912}{1501}$.

664. Yanvar ayi'nda 11 ku'n qar, 6 ku'n jawi'n jawdi'. Aydi'n' qanday bo'leginde hawa ashi'q bolg'an?

665. Yeger muzqaymaqti'n' $\frac{4}{5}$ bo'legin su't qurasa, 2 kg muzqaymaq tayarlaw ushi'n qansha su't kerak boladi'?



666. a ni'n' qanday ma'nisinde ten'lik wori'nli' boladi'?

a) $\frac{a}{22} + \frac{9}{22} = \frac{34}{22}$; b) $\frac{a}{47} + \frac{23}{47} = \frac{43}{47}$; d) $\frac{a}{79} - \frac{17}{79} = \frac{44}{79}$.

667. Yeger $b = \frac{11}{64}$ bo'lsa, $b - \frac{9}{64}$ an'latpani'n' ma'nisin tabi'n'.

668. 130 ar yegin maydani'n' $\frac{3}{10}$ bo'legine kartoshka ha'm $\frac{5}{10}$ bo'legine piyaz yegildi. Neshe ar yegin maydani' bos qaldi'?



669. Yeger $\frac{8}{24} + \frac{15}{24} = \frac{23}{24}$ yekenligi belgili bolsa, to'mendegi ten'lemeni sheshin':

a) $x - \frac{15}{24} = \frac{8}{24}$; b) $z + \frac{15}{24} = \frac{23}{24}$; d) $\frac{23}{24} - p = \frac{8}{24}$.

670. Ten'lemeni sheshin':

a) $z + \frac{15}{24} = \frac{23}{24}$; b) $\frac{27}{45} - x = \frac{18}{45} + \frac{3}{45}$; d) $y - \frac{7}{13} = \frac{12}{13} - \frac{3}{13}$.

671. Klasta 30 woqi'wshi' bar. Matematikadan wo'tkerilgen qadag'alaw jumi'si'nda woqi'wshi'lardi'n' $\frac{7}{15}$ bo'legi - «5», $\frac{5}{15}$ bo'legi - «4» ha'm qolgeni - «3» baha baha aldi'. Qansha woqi'wshi' «3» baha alg'an?

Usi' waqi'tqa shekem 2 ni 3 ke bo'lip bolmaydi', dep kelgen yedik. Sebebi, ha'r qanday natural sandi' 3 ke ko'beytkende 2 payda bolmaydi'. Bo'lshek sanlardi'n' barli'g'i'n bilip alg'annan son' buni'n' ila'ji tabi'ldi'. Buni' to'mendegi ma'sele mi'sali'nda tu'sindiriwge ha'reket yetemiz.

1- mi'sal. Yeki birdey almani' u'sh balag'a ten'dey bo'lip berin' (1-su'wret).

Sheshiliwi. Buni'n' ushi'n ha'r bir almani' ten' 3 bo'lekke bo'lemiz. Na'tiyjede 6 u'les (yag'ni'y almani'n' $\frac{1}{3}$ bo'legi) payda boladi'. Yendi bul u'leslerdi u'sh balag'a yekewden bo'lip bere alami'z.

Sonda, ha'r bir balag'a almani'n $\frac{1}{3} + \frac{1}{3} = \frac{2}{3}$ bo'legi tiyedi. $\frac{2}{3}$ bo'lshek 2 almani' 3 ten' bo'lekke bo'lgende payda boldi'.

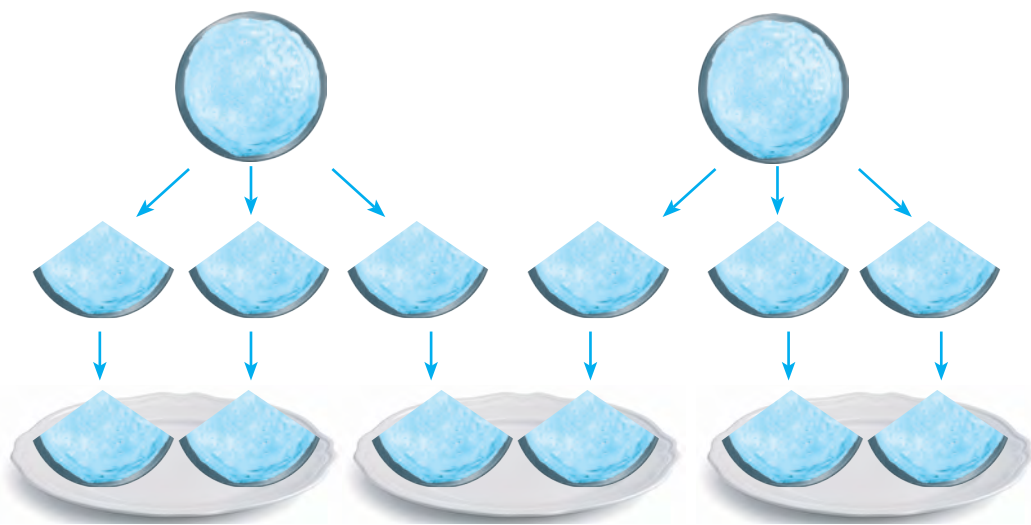

1- su'wret

Demek, $2 : 3 = \frac{2}{3}$ dep jazi'w mu'mkin. Soni'n' ushi'n bo'lshek si'zi'g'i'n bo'liw belgisi dep tu'siniw mu'mkin.



Ha'r qanday natural sanlardi' bo'liw na'tiyjesin bo'lshekler ja'rdeminde an'lati'w mu'mkin.

Eger bo'liw qaldi'qsi'z wori'n'lansa tiyindi natural sannan ibarat boladi'. Yeger bo'liw qaldi'qli' wori'n'lansa, tiyindi bo'lshek sannan ibarat boladi'.

Ma'selen, $32 : 4 = \frac{32}{4} = 8$, $5 : 1 = \frac{5}{1} = 5$, $4 : 7 = \frac{4}{7}$, $13 : 5 = \frac{13}{5}$.

2- mi'sal. 4 sani'n bo'limi 6 bolg'an bo'lshek ko'riniside an'lati'n'.

Sheshiliwi: Buni'n' ushi'n aldi'n sonday san tabi'wi'mi'z kerek, woni' 6 g'a bo'lgende 4 payda bolsi'n. Bul san-4 ha'm 6 sanlari'ni'n' ko'beymesinen ibarat boladi': $4 \cdot 6 = 24$.

Demek, $4 = \frac{24}{6}$.

Uli'wma alg'anda ha'r qanday natural sandi' bo'limi qa'legen natural san bolg'an bo'lshek ko'riniside an'lati'w mu'mkin. Bul bo'lshekti'n' ali'mi' berilgen natural san ha'm bo'limnin' ko'beymesinen ibarat boladi'.

Bo'limleri birdey bo'lsheklerdi qosi'w qag'i'ydas'i' an'lati'lg'an $\frac{a}{c} + \frac{b}{c} = \frac{a+b}{c}$ formulani' basqasha $a : c + b : c = (a + b) : c$ yamasa $(a + b) : c = a : c + b : c$ ko'riniside jazi'p ali'w mu'mkin.

Aqi'rg'i' jazi'w qos'i'ndi'ni' sang'a bo'liw qag'i'ydas'i'n an'latadi':

Qosi'ndi'ni' sang'a bo'liwde ha'r bir qosi'li'wshi'lardi' wo'z aldi'na bul sang'a bo'lip, son' payda bolg'an tiyindilerdi qosi'w jetkilikli.



Ma'selen:

$(1236 + 642 + 18) : 3 = 1236 : 3 + 642 : 3 + 18 : 3 = 412 + 214 + 6 = 632$.

Sorawlarg'a juwap berin'



1. Ha'r qanday natural sanlardi' bo'liw na'tiyjesin bo'lshek ja'rdeminde an'lati'w mu'mkin be?
2. Yeger bo'liw qaldi'qsi'z wori'n'lansa, tiyindi qanday san boladi'?
3. Yeger bo'liw qaldi'qli' wori'n'lansa, tiyindi qanday san boladi'?
4. Qosi'ndi'ni' sang'a bo'liw qag'i'ydas'i'n jazi'n' ha'm mi'sallarda tu'sindirin'?

Klasta wori'nlanatug'i'n shi'ni'g'i'wlar



672. Tiyindilerdi a'piwayi' bo'lshek ko'riniside an'lati'n':

- a) $3 : 7$; || b) $2 : 10$; || d) $14 : 23$; || e) $9 : 1$; || f) $25 : 5$; || g) $87 : 19$.

673. Su'wretten paydalani'p, natural sandi' bo'lshek ko'riniside jazi'n'.

a)  $2 = \frac{\quad}{8}$ || b)  $3 = \frac{\quad}{6}$

674. Bo'lshekti tiyindi ko'riniside an'lati'n' ha'm woni'n' ma'nisin tabi'n':

- a) $\frac{21}{3}$; || b) $\frac{24}{6}$; || d) $\frac{35}{7}$; || e) $\frac{2525}{25}$.

675. 5 bala 4 almani' ten' bo'lip aldi'. Wolardi'n' ha'r birine qansha alma tiydi?
676. Bir ha'ptede bir shan'araqta 18 nan jelindi. Bir kun'de shan'araqta qansha nan jelingeni'n bo'lshek ko'riniside an'lati'n'.
677. 2 pitsa 5 ta'relkag'a ten' qi'li'p bo'listirildi. Ha'r bir ta'relkige qansha pitsa qoyi'lg'ani'n bo'lshek ko'riniside an'lati'n'.
678. Ha'lima 35 minutta 2 km ju'rди. Wol 1 minutta qansha jol ju'rgeni'n bo'lshek ko'riniside an'lati'n'.
679. Poezd 15 minutta 20 km jol basi'p wo'tti. Wol 1 minutta qansha jol basi'p wo'tkeni'n bo'lshek ko'riniside an'lati'n'.



680. Qosi'ndi'ni' sang'a bo'liw ni'zami'na qollani'p an'latpani'n' ma'nisin tabi'n':
 a) $(34 + 51) : 17$; b) $(3434 + 68) : 34$; d) $156 : 26 + 364 : 26$;
 e) $(133 + 228) : 19$; f) $(952 + 3528) : 56$; g) $1107 : 123 + 1353 : 123$.
681. Kvadratti'n' perimetri 7 dm. Woni'n' ta'repin tabi'n'.
682. Tuvri'mu'yeshliktin' maydani' 19 sm^2 , bir ta'repi bolsa 7 sm. yekinshi ta'repin bo'lshek ko'riniside an'lati'n'.
683. 46 l su't 5 i'di'sqa ten'dey yetip quyi'ldi'. Ha'r bir i'di'sqa qansha su't quyi'lg'ani'n bo'lshek ko'riniside an'lati'n'.
684. 112 m si'm 23 ten' bo'lekke bo'lindi. Bir bo'lektin' uzi'nli'g'i'n bo'lshek ko'riniside an'lati'n'.



U'yde wori'nlanatug'i'n shi'ng'i'wlar

685. Tiyindilerdi a'piwayi' bo'lshek ko'riniside an'lati'n':
 a) $4 : 5$; b) $7 : 19$; d) $24 : 80$; e) $92 : 31$; f) $102 : 750$; g) $384 : 3490$.
686. Bo'lshek tiyindi ko'riniside an'lati'n' ha'm woni'n' ma'nisin tabi'n':
 a) $\frac{32}{8}$; b) $\frac{72}{18}$; d) $\frac{96}{8}$; e) $\frac{3131}{101}$.
687. 99 bir qi'yli' g'arbi'zdi'n' ja'mi massasi' 39 kg. Bir g'arbi'zdi'n' massasi'n bo'lshek ko'riniside an'lati'n'?



688. Velosipedshi 25 minutta 12 km jol basi'p wo'tti. Wol 1 minutta qansha jol basi'p wo'tkeni'n bo'lshek ko'riniside an'lati'n'.
689. Qosi'ndi'ni' sang'a bo'liw ni'zami'na qarap an'latpani'n' ma'nisin tabi'n':
 a) $(204 + 408) : 17$; b) $(516 + 2193) : 43$; d) $462 : 33 + 528 : 33$.
690. Kvadratti'n' perimetri 54 dm. Woni'n' ta'repin bo'lshek ko'riniside an'lati'n'.
691. Tuvri'mu'yeshliktin' maydani' 232 sm^2 , bir ta'repi bolsa 47 sm. Yekinshi ta'repin bo'lshek ko'riniside an'lati'n'.

32- §

ARALAS SANLAR

1- mi'sal. 4 almani' u'sh balag'a ten' bo'lip berin' (1.a-su'wret).

Sheshiliwi. Ma'seleni yeki tu'rli usi'da sheshiw mu'mkin.

1- usul. Ha'r bir almani' 3 ten'dey bo'lekke bo'lemiz (1.b-su'wret) ha'm ha'r bir balag'a 3 bo'lekten beremiz. Na'tiyjede ha'r bir balag'a almani'n' $\frac{3}{2}$ bo'legi tiyisedi.

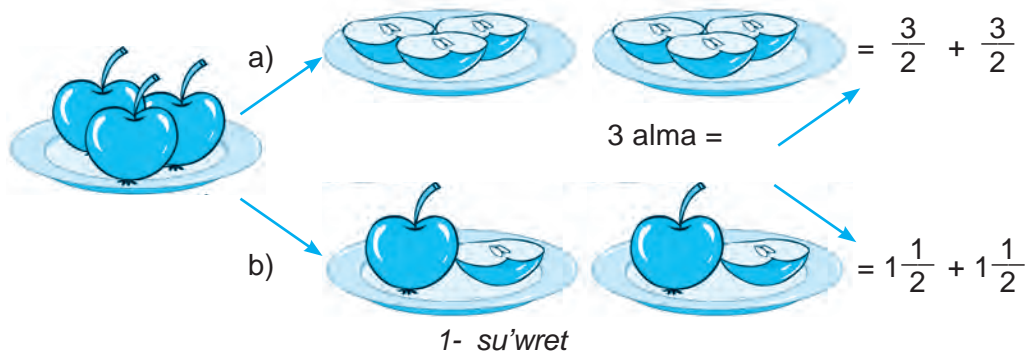

2- usi'l. Aldi'n balalarg'a bir pu'tin almadan beremiz, son' qalg'an bir almani' 3 bo'lekke bo'lip, ha'r bir balag'a bir bo'lekten beremiz. Na'tiyjede, ha'r bir balag'a bir pu'tin alma ha'm almani'n' $\frac{1}{2}$ bo'legin, ja'mi $1 + \frac{1}{2}$ bo'legi tiyisedi (1.b- su'wret).

Demek, ha'r yeki halda da balalarg'a bir qi'yli' mug'dardag'i' alma tiyisedi, yag'ni'y $\frac{3}{2} = 1 + \frac{1}{2}$ boladi'.

$1 + \frac{1}{2}$ qosi'ndi'ni' qi'sqasha $1\frac{1}{2}$ tu'rinde jazi'w qabi'l yetilgen ha'm wol «bir pu'tin yekiden bir» dep woqi'ladi'.

Solay yetip, $\frac{3}{2} = 1\frac{1}{2}$ an'latpag'a iyemiz.

$1\frac{1}{2}$ aralash sanni'n' an'latpasi' boli'p, 1 – woni'n' pu'tin bo'legi, $\frac{1}{2}$ bolsa bo'lshek bo'legi dep ju'ritiledi.

Pu'tin ha'm bo'lshek bo'limleri aji'rati'li'p jazi'lg'an sanlar, aralas sanlar dep ataladi'.

32.1. Naduri's bo'lshekli aralas san ko'riniside an'lati'w

9 di' 4 ke qaldi'qli' bo'liwdi yesleyik (2- su'wret):

Bunda 4 – bo'liwshi, 2 – toli'q yemes tiyindi, to'mendegi 1 sani' bolsa qaldi'q.

Demek, $\frac{9}{4} = 2 + \frac{1}{4} = 2\frac{1}{4}$



Demek, aralas sannin' pu'tin bo'legi toliq yemes tiyindiden, bo'lshek bo'leginin' ali'mi' bolsa qaldiqtan ibarat boladi'.

Naduri's bo'lshektin' aralas san ko'riniside an'latiw (yag'ni'y woni'n' pu'tin bo'legin aji'rati'w) ushi'n:

- 1) bo'lshektin' ali'mi' bo'limine qaldiqli' bo'linedi;
- 2) toliq yemes tiyindi aralas sannin' pu'tin bo'legi boladi';
- 3) qaldi'q (eger bar bolsa) aralas san bo'lshek bo'leginin' ali'mi', bo'liwshi bolsa bo'limi boladi'.

2- mi'sal. $\frac{23}{7}$ naduri's bo'lshektin' pu'tin bo'legin $\frac{23}{7} \begin{matrix} | 7 \\ \hline 21 \\ \hline 2 \end{matrix}$ \leftarrow bo'limi
 aji'rati'n'. $\frac{21}{3} \leftarrow$ pu'tin bo'legi
 $\frac{2}{2} \leftarrow$ ali'mi'

Sheshiw. 23 ti 7 ge bo'lemiz. Na'tiyjede toliq yemes tiyindi 3, qaldi'q bolsa 2 yekenligin tabami'z (3- su'wret).

3- su'wret

Demek, $\frac{23}{7} = 3 \frac{2}{7}$.

32.2. Aralas sandi' naduri's bo'lshek ko'riniside an'latiw

3- mi'sal. $2 \frac{3}{5}$ aralas sandi' naduri's bo'lshek ko'riniside an'lati'n'.

Sheshiw. Bizge belgili, $2 \frac{3}{5} = 2 + \frac{3}{5}$. 2 sani'n bolsa bo'limi 5 ke ten' bolg'an bo'lshek ko'riniside an'latiw mu'mkin: $2 = \frac{2 \cdot 5}{5} = \frac{10}{5}$.

Demek, $2 \frac{3}{5} = 2 + \frac{3}{5} = \frac{10}{5} + \frac{3}{5} = \frac{13}{5}$ (4- su'wret).

$$2 \frac{3}{5} = \frac{13}{5}$$

4- su'wret

Aralas sandi' naduri's bo'lshek ko'riniside su'wretlew ushi'n:

- 1) sannin' pu'tin bo'legin bo'limge ko'beytiw kerek;
- 2) payda bolg'an ko'beymege ali'mdi' qosi'w kerek;
- 3) naduri's bo'lshek ali'mi'na payda bolg'an qosi'ndi'ni', bo'limine bolsa bo'lshek bo'lek bo'limin jazi'w kerek (4- su'wret).

Aralas sandi' naduri's bo'lshekke aylandiri'w qag'i'ydasin' 5- su'wret tiykari'nda da tu'sindiriv mu'mkin.

$$3 \frac{1}{2} = \frac{1}{2} + \frac{1}{2} + \frac{1}{2} + \frac{1}{2} + \frac{1}{2} + \frac{1}{2} + \frac{1}{2} + \frac{1}{2} = \frac{7}{2}$$

$$3 \frac{1}{2} = \frac{2 \cdot 3 + 1}{2} = \frac{7}{2}$$

5- su'wret

Sorawlarg'a juwap berin'



1. Aralas san dep qanday sang'a ayti'ladi'?
2. Aralas sannin' pu'tin ha'm bo'lshek bo'legi qalay tabi'ladi'?
3. Naduri's bo'lshek aralas san ko'riniside qalay an'lati'ladi'?
4. Aralas san naduri's bo'lshekke qalay aylandi'ri'ladi'?

Klasta wori'nlanatug'i'n shi'ni'g'i'wlar



692. Cifrlar menen jazi'n':

a) yeki pu'tin segizden bes; b) alti' pu'tin u'shten jети; d) bir pu'tin jigirma u'shten won to'rt; e) segiz pu'tin woti'z u'shten jigirma yeki.

693. Sandi' pu'tin ha'm bo'lshek bo'lekleri qosi'ndi'si' ko'riniside an'lati'n':

a) $2\frac{5}{14}$; || b) $1\frac{3}{4}$; || d) $4\frac{9}{11}$; || e) $12\frac{9}{31}$; || f) $3\frac{18}{44}$; || g) $103\frac{1}{101}$.

694. Figuralardi' da'pterin'izge si'zi'n'. Wolardi' tiyisli bo'leklerge bo'lin' ha'm ten'liklerde tu'sirip qaldi'ri'lg'an sanlardi' jazi'n'.

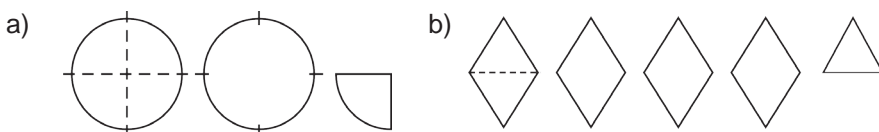

$$2\frac{1}{4} = 2 + \frac{1}{4} = \frac{4}{4} + \frac{1}{4} = \frac{5}{4};$$

$$4\frac{1}{2} = 4 + \frac{1}{2} = \frac{2}{2} + \frac{1}{2} = \frac{3}{2}.$$

695. Qosi'ndi'ni' aralas san ko'riniside an'lati'n':

a) $4 + \frac{5}{24}$; || b) $5 + \frac{31}{34}$; || d) $14 + \frac{5}{11}$; || e) $42 + \frac{19}{301}$; || f) $23 + \frac{485}{844}$; || g) $143 + \frac{134}{1015}$.

696. Tiyindini aralas san ko'riniside an'lati'n':

a) $23 : 6$; || b) $37 : 11$; || d) $121 : 35$; || e) $56 : 23$; || f) $223 : 126$.

697. Naduri's bo'lshekti aralas sang'a aylandi'ri'n:

a) $\frac{77}{14}$; || b) $\frac{37}{24}$; || d) $\frac{89}{11}$; || e) $\frac{94}{31}$; || f) $\frac{180}{44}$; || g) $\frac{1001}{101}$.

698. Su'wretten paydalani'p $2\frac{3}{5}$ aralas sandi' naduri's bo'lshekke aylanti'ri'n'.

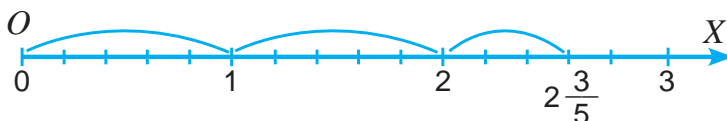

699. Sandi' naduri's bo'lshek ko'riniside an'lati'n':

a) $1\frac{5}{7}$; || b) $3\frac{3}{4}$; || d) $2\frac{9}{15}$; || e) $7\frac{9}{316}$; || f) $12\frac{218}{494}$; || g) $112\frac{451}{1001}$.

700. Da'pterin'izge sanlar nuri'n si'zi'n'. Birlik kesindi si'pati'nda uzi'nli'g'i' 4 ketekshe uzi'nli'g'i'na ten' bolg'an kesindini ali'n'. Sanlar nuri'nda to'mendegi sanlardi' su'wretlen':

- a) $1\frac{1}{2}$; || b) $2\frac{3}{4}$; || d) $3\frac{1}{4}$; || e) $2\frac{1}{2}$; || f) $2\frac{1}{4}$; || g) $3\frac{1}{2}$.



701. Qosi'wdi' wori'nlan' ha'm na'tiyjeni aralas san ko'riniside an'lati'n':

- a) $\frac{3}{7} + \frac{6}{7}$; || b) $\frac{11}{12} + \frac{4}{12}$; || d) $\frac{11}{13} + \frac{9}{13}$; || e) $\frac{23}{29} + \frac{14}{29}$; || f) $\frac{13}{17} + \frac{11}{17} + \frac{8}{17}$.

702. Saatlarda an'lati'n':

- a) 2 saat 34 minut; || b) 4 saat 43 minut; || d) 6 saat 14 minut.

U'lg'i: a) 2 saat 34 minut = $(2 + \frac{34}{60})$ saat = $2\frac{34}{60}$ saat.

703. Shan'araqta bir ha'ptede 12 kg kartoshka jelindi. Shan'araqta bir ku'nde wortasha neshe kg kartoshka jelingeligin tabi'n? Juwapti' aralas san ko'riniside an'lati'n'.

704. Uzi'nli'g'i' $2\frac{9}{15}$ m bolg'an si'm, ha'rbiri $\frac{1}{15}$ m bolg'an si'm, ha'r biri neshta bo'lek si'm payda boldi'?

705. Su'wretten paydalani'p, naduri's bo'lshekti aralas san ko'riniside jazi'n'.

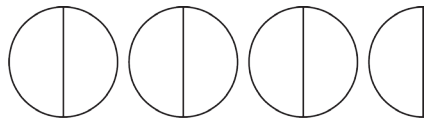

a) $\frac{7}{2} = 3\frac{1}{2}$;

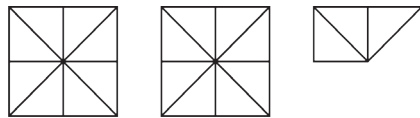

b) $\frac{19}{8} = \underline{\hspace{2cm}}$;

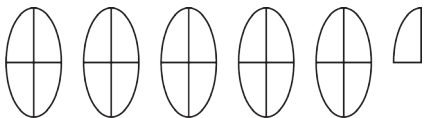

d) $\frac{21}{4} = \underline{\hspace{2cm}}$;

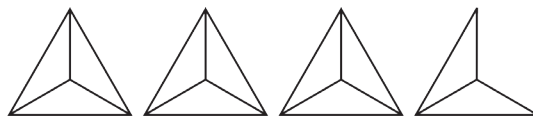

e) $\frac{11}{3} = \underline{\hspace{2cm}}$.

706. Ali'm: "Boyi'm $\frac{9}{6000}$ km, salmag'i'm bolsa $\frac{2}{50}$ t" dep aytti'. Wol aljasi'p ati'rg'an joq pa?



U'yde wori'nlanatug'i'n shi'ng'i'wlar

707. Qosi'ndi'ni' aralas san ko'riniside an'lati'n':

- a) $2 + \frac{5}{14}$; || b) $7 + \frac{3}{41}$; || d) $3 + \frac{9}{131}$; || e) $2 + \frac{9}{311}$.

708. Naduri's bo'lshekti aralas sang'a aylandi'ri'n':

a) $\frac{56}{17}$; || b) $\frac{77}{34}$; || d) $\frac{99}{12}$; || e) $\frac{394}{86}$.

709. Sandi' naduri's bo'lshek ko'rinishinde an'lati'n':

a) $3\frac{5}{8}$; || b) $2\frac{4}{9}$; || d) $12\frac{17}{25}$; || e) $12\frac{55}{87}$.



710. Qosi'wdi' wori'nlan' ha'm na'tiyjeni aralas san ko'rinishinde an'lati'n':

a) $\frac{3}{5} + \frac{4}{5}$; || b) $\frac{9}{12} + \frac{14}{12}$; || d) $\frac{7}{8} + \frac{5}{8}$; || e) $\frac{13}{25} + \frac{14}{25}$; || f) $\frac{13}{19} + \frac{11}{19} + \frac{7}{19}$.

711. Kilometrde an'lati'n':

a) 6 km 200 m; || b) 18 km 750 m; || d) 11 km 925 m.

712. Avtomobil 250 km arali'qti' 3 saatta basi'p wo'tken bolsa avtomobildin' tezligin tabi'n'? Juwapti' aralas san ko'rinishinde an'lati'n'.

713. Jumi'sshi' 8 saatta 145 dana metal tayarladi'. Wol 1 saatta neshe detal tayarlag'an? Juwapti' aralas san ko'rinishinde an'lati'n'.

Qi'ziqli' matematikag'a tiyisli ma'seleler



“Bo'lshekli keste” jumbag'i

“Noller ha'm krestler” woyi'ni'n bilsen'iz kerek. Wonda kvadrat ko'rinishidegi kestenin' qandayda qatari', bag'anasi' yamasa diaganali' boyi'nsha tek “0” yamasa “x” belgisi jazi'lsa, woyi'n tamamlanadi'. Usi' woyi'ng'a uqsas, “bo'lshekli keste” jumbag'i'n sheshin'.

0	x	
x	0	x
0	x	0

To'mende berilgen kestelerden sonday qatar, bag'ana yamasa dioganali'n tabi'n', wolarda turg'an sanlar qosi'ndi'si' kestenin' to'besine jazi'lg'an bo'lshekke ten' bolsi'n.

$$6\frac{5}{9}$$

$\frac{4}{9}$	$5\frac{3}{9}$	4
$4\frac{1}{9}$	$1\frac{4}{9}$	$1\frac{5}{9}$
$2\frac{4}{9}$	$\frac{2}{9}$	$3\frac{8}{9}$

$$7\frac{3}{5}$$

$4\frac{3}{5}$	$1\frac{3}{5}$	$2\frac{1}{5}$
$3\frac{1}{5}$	$3\frac{4}{5}$	4
$1\frac{3}{5}$	$4\frac{1}{5}$	$\frac{2}{5}$

$$8\frac{3}{8}$$

$4\frac{1}{8}$	$1\frac{3}{8}$	$1\frac{5}{8}$
$\frac{7}{8}$	$2\frac{6}{8}$	$4\frac{2}{8}$
$2\frac{3}{8}$	$3\frac{7}{8}$	$2\frac{4}{8}$

33- §

ARALAS SANLARDI QOSIW HA'M ALIW

Aralas sanlardi' qosi'w ha'm ali'w bul a'mellerdin' qa'siyetleri tiykari'nda wori'nlanadi'.

1- mi'sal. $5\frac{2}{7}$ ha'm $3\frac{1}{7}$ sanlardi'n' qosi'ndi'si'n tabi'n'.

Sheshiw: $5\frac{2}{7} = 5 + \frac{2}{7}$ ha'm $3\frac{1}{7} = 3 + \frac{1}{7}$ bolg'ani' ushi'n

$$5\frac{2}{7} + 3\frac{1}{7} = 5 + \frac{2}{7} + 3 + \frac{1}{7} = 5 + 3 + \frac{2}{7} + \frac{1}{7} = 8 + \frac{3}{7} = 8\frac{3}{7}.$$

Bul qi'sqasha to'mendegi ko'riniste jazi'ladi':

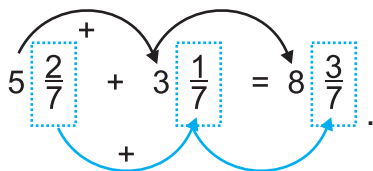

2- mi'sal. $3\frac{3}{5}$ ha'm $1\frac{1}{5}$ sanlari'ni'n' ayi'rmasi'n tabi'n'.

Sheshiw:

$$3\frac{3}{5} - 1\frac{1}{5} = 3 + \frac{3}{5} - (1 + \frac{1}{5}) = 3 + \frac{3}{5} - 1 - \frac{1}{5} = (3 - 1) + (\frac{3}{5} - \frac{1}{5}) = 2 + \frac{2}{5} = 2\frac{2}{5}.$$

Bul qi'sqasha to'mendegi ko'riniste jazi'ladi':

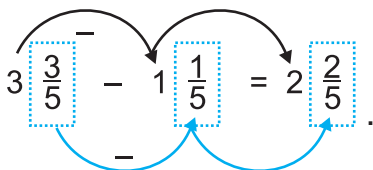

Aralas sanlardi' qosi'wda (ali'wda) wolardi'n' pu'tin ha'm bo'lshek bo'lekleri wo'z aldi'na qosi'ladi' (ali'nadi').

Geyde aralas sanlardi' qosi'wda bo'lshek bo'lekleri qosi'ndi'si' naduri's bo'lshek boli'wi' mu'mkin. Bunday jag'daylarda naduri's bo'lshekin' pu'tin bo'legi aji'rati'ladi' ha'm pu'tin bo'lekler qosi'ndi'g'a qosi'ladi'.

3- mi'sal. $2\frac{5}{7} + 3\frac{4}{7} = 5\frac{9}{7} = 5 + \frac{9}{7} = 5 + 1\frac{2}{7} = 5 + 1 + \frac{2}{7} = 6\frac{2}{7}$

Geyde, aralas sanlardi' ali'wda azayi'wshi'ni'n' bo'lshek bo'legi, ali'ni'wshi'ni'n' bo'lshek bo'leginen kishi boli'wi' mu'mkin. Bunday jag'daylarda 1 pu'tin «maydalanadi'».

Buni' to'mendegi mi'sallarda ko'riw mu'mkin:

$$4\text{- misol. } 5\frac{2}{9} - 2\frac{4}{9} = (5 + \frac{2}{9}) - 2\frac{4}{9} = (4 + 1 + \frac{2}{9}) - 2\frac{4}{9} = (4 + 1\frac{2}{9}) - 2\frac{4}{9} = (4 + \frac{11}{9}) - 2\frac{4}{9} = 4\frac{11}{9} - 2\frac{4}{9} = 2\frac{7}{9}.$$

Bul qi'sqasha $5\frac{2}{9} - 2\frac{4}{9} = 4\frac{11}{9} - 2\frac{4}{9} = 2\frac{7}{9}$ ko'risinde jazi'ladi'.

Pu'tin sannan bo'lshek san ali'ng'anda da tap sonday jol tuti'ladi', yag'ni'y 1 pu'tin «maydalanadi».

Buni' to'mendegishe mi'sallarda ko'riw mu'mkin:

$$5\text{- misol. } 6 - \frac{3}{7} = 5\frac{7}{7} - \frac{3}{7} = 5\frac{4}{7}; \quad 7 - 2\frac{1}{3} = 6\frac{3}{3} - 2\frac{1}{3} = 4\frac{2}{3}.$$

Sorawlarg'a juwap berin'



1. Aralas sanlar qalay qosi'ladi'?
2. Aralas sanlardi' qosi'wda bo'lshek bo'limlerinin' qosi'ndi'si' naduri's bo'lshek boli'p qalsa, qanday jol tuti'ladi'?
3. Azayi'wshi'ni'n' bo'lshek bo'legi ali'ni'wshi'nikinen kishi bolg'anda aralas sanlar bir-birinen qalay ali'nadi'?
4. Pu'tin qanday "maydalanadi"? Mi'sal menen tu'sindirir'.

Klasta wori'nlanatug'i'n shi'ni'g'i'wlar



714. (Awi'zeki) yesaplan' ha'm qosi'ndi'ni' qalay tapqani'n'i'zdi' tu'sindirir'.

a) $2\frac{1}{3} + 1;$

b) $3\frac{2}{3} + 2;$

d) $4 + 2\frac{2}{5};$

e) $3\frac{1}{5} + \frac{2}{5};$

f) $7\frac{1}{4} + \frac{1}{4};$

g) $4\frac{2}{7} + \frac{3}{7}.$

715. Qosi'ndi'ni' tabi'n'.

a) $1\frac{1}{12} + 2\frac{1}{12};$

b) $3\frac{5}{9} + 1\frac{1}{9};$

d) $4\frac{2}{9} + 1\frac{1}{9};$

e) $3\frac{3}{8} + 1\frac{1}{8};$

f) $4\frac{3}{10} + 6\frac{1}{10};$

g) $12\frac{1}{15} + 3\frac{4}{15}.$

U'lg'i: Joqari'da sheshilgen 1- mi'sal.

716. Qosi'ndi'ni' tabi'n' ha'm na'tiyjeni aralas san ko'risinde su'wretlen':

a) $\frac{3}{8} + \frac{7}{8};$

b) $\frac{6}{11} + \frac{8}{11};$

d) $\frac{2}{3} + \frac{2}{3};$

e) $\frac{11}{12} + \frac{7}{12}.$

U'lg'i: Joqari'da sheshilgen 3- mi'sal.

717. Qosi'ndi'ni' tabi'n':

a) $3\frac{1}{2} + \frac{1}{2}$; || b) $\frac{3}{4} + 1\frac{1}{4}$; || d) $4\frac{1}{3} + 1\frac{2}{3}$; || e) $2\frac{3}{8} + 3\frac{5}{8}$.

U'lgj: Joqari'da sheshilgen 3- mi'sal.

718. Qosi'ndi'ni' tabi'n'.

a) $\frac{1}{5} + \frac{2}{5} + 7$; || b) $\frac{1}{8} + 2 + \frac{3}{8}$; || d) $10 + \frac{1}{8} + \frac{3}{8}$; || e) $5\frac{1}{13} + \frac{4}{13} + \frac{5}{13}$.



719. Qosi'ndi'ni' tabi'n':

a) $5\frac{4}{5} + 2\frac{2}{5}$; || b) $2\frac{7}{16} + 2\frac{3}{16}$; || d) $10\frac{5}{8} + 1\frac{3}{8}$; || e) $5\frac{3}{5} + 3\frac{4}{5}$.

U'lgj: Joqari'da sheshilgen 3-mi'sal.

720. (Awi'zeki) Ayi'rmani' tabi'n':

a) $3\frac{1}{2} - 2$; || d) $5\frac{7}{9} - 3$; || f) $6\frac{1}{7} - 1$;
 b) $5\frac{2}{3} - 4$; || e) $12\frac{1}{4} - 9$; || g) $7\frac{3}{4} - 4$.

721. (Awi'zeki) Pu'tindi maydalaw usi'li' menen ayi'rmani' yesaplan':

a) $1 - \frac{1}{2}$; || b) $1 - \frac{2}{5}$; || d) $1 - \frac{1}{3}$; || e) $1 - \frac{3}{10}$;
 f) $1 - \frac{3}{4}$; || g) $1 - \frac{7}{9}$; || h) $1 - \frac{11}{20}$; || i) $1 - \frac{15}{25}$.

U'lgj: Joqari'da sheshilgen 5-mi'sal.

722. Ayirmani tabi'n':

a) $3 - \frac{1}{3}$; || b) $6 - \frac{3}{7}$; || d) $4 - \frac{1}{9}$; || e) $8 - \frac{2}{3}$;
 f) $5 - \frac{2}{5}$; || g) $7 - \frac{5}{8}$; || h) $6 - \frac{1}{3}$; || i) $2 - \frac{5}{6}$.

U'lgj: Joqari'da sheshilgen 5- mi'sal.

723. Ayi'rmani' tabi'n':

a) $5 - 2\frac{1}{2}$; || b) $6 - 1\frac{1}{2}$; || d) $6 - 3\frac{2}{5}$; || e) $4 - 2\frac{3}{5}$;
 f) $7 - 5\frac{3}{7}$; || g) $7 - 1\frac{2}{3}$; || h) $8 - 3\frac{2}{4}$; || i) $4 - 1\frac{1}{6}$.

U'lgj: Joqari'da sheshilgen 5-mi'sal.

724. Paraxodti'n' ti'ni'q suwdag'i' tezligi 22 km/saat. Da'rya ag'i'mi'ni'n' tezligi bolsa $2\frac{2}{3}$ km/saat, paraxodti'n' ag'i'mg'a qarsi' tezligin tabi'n'.

725. Du'kandag'i' 12 t kartoshkani'n' $7\frac{3}{5}$ t nasi' sati'ldi'. Du'kanda qansha kartoshka qaldi'?



726. Ayi'rmani' tabi'n':

a) $5\frac{2}{3} - \frac{1}{3}$;

d) $4\frac{5}{7} - \frac{3}{7}$;

f) $2\frac{3}{5} - \frac{3}{5}$;

b) $7\frac{5}{8} - \frac{1}{8}$;

e) $10\frac{8}{9} - \frac{2}{9}$;

g) $1\frac{3}{4} - \frac{1}{4}$.

727. Ayi'rmani' tabi'n':

a) $6\frac{3}{4} - 2\frac{1}{4}$;

d) $3\frac{2}{5} - 1\frac{1}{5}$;

f) $7\frac{3}{5} - \frac{3}{5}$;

b) $4\frac{7}{8} - 2\frac{1}{8}$;

e) $9\frac{2}{11} - 8\frac{1}{11}$;

g) $4\frac{2}{5} - 4\frac{1}{5}$.

U'lgi: Joqari'da sheshilgen 2- mi'sal.

728. Ayi'rmani' tabi'n':

a) $1\frac{5}{9} - \frac{8}{9}$;

b) $1\frac{1}{12} - \frac{5}{12}$;

d) $8\frac{3}{7} - 5\frac{5}{7}$;

e) $4\frac{1}{8} - 1\frac{5}{8}$.

U'lgi: Joqari'da sheshilgen 4- mi'sal.

729. Su'wretlerdi toltiri'n' ha'm wolar ja'rdeminde ayi'rmani' tabi'n'.

$\square \square \square - \square \square = \underline{\hspace{2cm}}$

$3 - 1\frac{3}{4} = 2\frac{3}{4} - 1\frac{3}{4} = \underline{\hspace{2cm}}$.

$\bigcirc \bigcirc \bigcirc \bigcirc - \bigcirc \bigcirc = \underline{\hspace{2cm}}$

$4\frac{1}{3} - 2\frac{2}{3} = 3\frac{2}{3} - 2\frac{2}{3} = \underline{\hspace{2cm}}$.

730. Da'rya ag'i'mi'ni'n' tezligi $2\frac{3}{4}$ km/saat, qayi'qti'n' ti'ni'q suwdag'i' tezligi bolsa $14\frac{1}{4}$ km/saat. Qayi'qti'n' ag'i'mg'a qarsi' tezligin tabi'n'.

731. Tuwri'mu'yeshliktin' yeni $12\frac{5}{8}$ sm, uzi'nli'g'i' bolsa wonnan $7\frac{3}{8}$ sm uzi'n. Tuwri'mu'yeshliktin' biykli'g'i'n tabi'n'.

732. A'mellerdi wori'nlan':

a) $5\frac{5}{9} + 2\frac{8}{9}$;

d) $7\frac{1}{12} - 4\frac{5}{12}$;

f) $8\frac{3}{7} + 5\frac{5}{7}$;

h) $4\frac{1}{8} - 1\frac{5}{8}$;

b) $5\frac{5}{9} - \frac{8}{9}$;

e) $7\frac{11}{12} + 4\frac{5}{12}$;

g) $8 - 5\frac{5}{7}$;

i) $6\frac{1}{22} - 2\frac{5}{22}$.

733. Tuwri'mu'yeshliktin' yeni $12\frac{5}{8}$ sm, uzi'nli'g'i' bolsa wannan $7\frac{3}{8}$ uzi'n. Tuwri'mu'yeshliktin' biyikli'g'i'n tabi'n'.

734. Su'wretten paydalani'p aralas sanlar u'stinde a'mellerdi wori'nlan':

a)  = _____
 $2\frac{1}{4} + 1\frac{2}{4} =$ _____ .

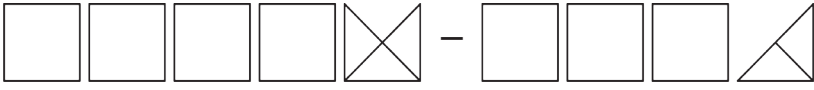
b)  = _____
 $4\frac{3}{4} - 3\frac{2}{4} =$ _____ .

d)  = _____
 $3\frac{5}{6} - \frac{3}{6} =$ _____ .

e)  = _____
 $2\frac{1}{2} + 3 =$ _____ .

735. An'latpani'n' ma'nisin tabi'n':

a) $5\frac{5}{9} + 2\frac{1}{9} + 1\frac{2}{9}$; d) $7\frac{1}{3} + 4\frac{1}{3} + \frac{2}{3}$; f) $8\frac{3}{8} + 5\frac{5}{8} - 2\frac{7}{8}$;
 b) $8\frac{5}{11} - 3\frac{8}{11} + 4\frac{9}{11}$; e) $5\frac{11}{21} + 4\frac{5}{21} - 6\frac{7}{21}$; g) $8\frac{3}{7} - 3\frac{5}{7} - 2\frac{6}{7}$.

736. U'lgige qarap ayi'rmani' tabi'n' ha'm yesaplaw usi'li'n tu'sindirir':

a) $3\frac{5}{9} - \frac{7}{9}$; b) $4\frac{8}{15} - \frac{14}{15}$; d) $9\frac{1}{19} - 2\frac{18}{19}$; e) $5\frac{19}{53} - 3\frac{36}{53}$.

U'lgij: a) $\frac{7}{9} = 1 - \frac{2}{9}$ yekenciliginen paydalanami'z. Aldi'n ali'ni'wshi'ni' wog'an yen' jaqi'n turg'an pu'tin san (1) menen almasti'rami'z ha'm ayi'rma wo'zgermewi ushi'n $\frac{2}{9}$ di' qqosi'p qoyami'z $3\frac{5}{9} - \frac{7}{9} = (3\frac{5}{9} - 1) + \frac{2}{9} = 2\frac{5}{9} + \frac{2}{9} = 2\frac{5+2}{9} = 2\frac{7}{9}$.

737. Tuwri'mu'yeshliktin' yeni $4\frac{5}{11}$ dm, uzi'nli'g'i' bolsa $6\frac{7}{11}$ dm. Tuwri'mu'yeshliktin' perimetritin' tabi'n'.

U'yde wori'nlantug'i'n shi'ni'g'i'wlar



738. Qosi'ndi'ni' tabi'n'.

a) $3\frac{1}{11} + 2\frac{3}{11}$; || b) $6\frac{5}{7} + 9\frac{1}{7}$; || d) $3\frac{7}{13} + 2\frac{5}{13}$.

739. Qosi'ndi'ni' tabi'n'.

a) $5\frac{1}{3} + \frac{2}{3}$; || b) $\frac{5}{7} + 1\frac{2}{7}$; || d) $5\frac{1}{5} + 2\frac{4}{5}$; || e) $1\frac{3}{4} + 5\frac{1}{4}$.

740. Qosi'ndi'ni' tabi'n'.

a) $\frac{4}{9} + \frac{2}{9} + 1$; || b) $\frac{4}{11} + 3 + \frac{3}{11}$; || d) $1\frac{5}{12} + \frac{1}{12} + \frac{1}{12}$; || e) $12 + \frac{5}{6} + \frac{1}{6}$.

741. Qosi'ndi'ni' tabi'n'.

a) $3\frac{8}{17} + 2\frac{13}{17}$; || b) $6\frac{9}{14} + 2\frac{13}{14}$; || d) $1\frac{5}{7} + 1\frac{6}{7}$; || e) $5\frac{7}{8} + 3\frac{3}{8}$.

U'lgi: Joqari'da sheshilgen 2-mi'sal.



742. Ayi'rmani' tabi'n':

a) $1 - \frac{1}{5}$; || b) $2 - \frac{1}{8}$; || d) $3 - \frac{5}{6}$; || e) $7 - \frac{3}{7}$.

743. Ayi'rmani' tabi'n':

a) $5\frac{1}{4} - 3$; || b) $11\frac{3}{8} - 5$; || d) $3\frac{5}{8} - 2$.

744. Ayi'rmani' tabi'n':

a) $5 - 1\frac{2}{3}$; || b) $11 - 7\frac{11}{15}$; || d) $12 - 8\frac{5}{8}$; || e) $3 - 1\frac{13}{14}$.

745. Da'rya ag'i'mi'ni'n' tezligi $2\frac{5}{7}$ km/saat, qayi'qti'n' ti'ni'q suwdag'i' tezligi $15\frac{3}{7}$ km/saat. Qayi'qti'n' ag'i'm boylap tezligin tabi'n'.



746. Ayi'rmani' tabi'n':

a) $6\frac{2}{7} - \frac{1}{7}$; || b) $5\frac{5}{11} - \frac{2}{11}$; || d) $3\frac{7}{12} - \frac{7}{12}$.

747. Ayi'rmani' tabi'n':

a) $3\frac{3}{5} - 2\frac{1}{5}$; || b) $13\frac{8}{15} - 1\frac{7}{15}$; || d) $4\frac{4}{7} - 1\frac{2}{7}$.

748. Ayi'rmani' tabi'n':

a) $5\frac{6}{13} - \frac{9}{13}$; || b) $9\frac{3}{14} - \frac{5}{14}$; || d) $12\frac{13}{23} - 5\frac{21}{23}$; || e) $3\frac{67}{83} - 1\frac{75}{83}$.

749. Du'kandag'i' 15 t kartoshkani'n $3\frac{5}{8}$ tonnasi' sati'ldi'. Du'kanda qansha kartoshka qaldi'?

750. Tuvri'mu'yeshliktin' uzi'nli'g'i' $5\frac{5}{13}$ dm, yeni bolsa wonnan $2\frac{7}{13}$ dm qi'sqa. Tuvri'mu'yeshliktin' yenin tabi'n'.



751. A'mellerdi wori'nlan':

a) $4\frac{5}{7} + 3\frac{6}{7}$; || b) $7\frac{1}{13} - 5\frac{5}{13}$; || d) $18\frac{12}{17} + 5\frac{15}{17}$; || e) $24\frac{5}{9} - 21\frac{7}{9}$.

752. An'latpani'n' ma'nisin tabi'n':

a) $1\frac{5}{7} + 2\frac{3}{7} + 1\frac{4}{7}$; || b) $13\frac{4}{7} + 5\frac{5}{7} - 2\frac{6}{7}$; || d) $5\frac{1}{5} - 3\frac{3}{5} + 4\frac{4}{5}$;
 e) $7\frac{11}{16} + 2\frac{5}{16} - 8\frac{7}{16}$; || f) $24\frac{1}{15} - 12\frac{4}{15} - 2\frac{3}{15}$; || g) $8\frac{2}{5} - 1\frac{4}{5} - 2\frac{3}{5}$.

753. U'shmu'yeshliktin' ta'replari $15\frac{8}{10}$ dm, $2\frac{9}{10}$ dm ha'm $11\frac{1}{10}$ dm. Woni'n' perimetrin tabi'n'.



Qi'ziqli' matematikag'a tiyisli ma'seleler

Figuralar belgili ni'zam tiykari'nda qatarg'a jaylasti'ri'lg'an. Qatardi'n' gezektegi figurasi'n si'zi'n'.

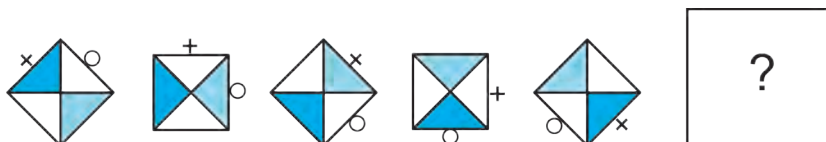

34- §

V BAPTI TA'KIRARLAWG'A TIYISLI MA'SELELER

754. 1 t biydaydan 780 kg un, 25 kg, 195 kg kepek ali'nadi'. 50 t biydaydan qansha un, usaq ha'm kepek ali'nadi'?
755. a) Tashkent teleminarasi'ni'n' biyikligi 375 m. Teleminara diywali'ni'n' biyikligi woni'n' $1/33$ bo'legin quraydi'. Diywaldi'n' biyikligin tabi'n'.
b) Tashkent teleminarasi'ni'n' uzi'nli'g'i' 93 m bolg'an ayaqlar uslap turadi'. Ayaqlar minara biyikliginin' qanday biyikligin quraydi'?
756. To'mendegi su'wretlerde do'n'gelektin' alti'dan bir u'lesleri berilgen. Wolardi' bo'lshek ko'rinishide an'lati'n'. Bul bo'lsheklerdin' qaysi'lari' 1 ge ten'? 1 den u'lken? 1 den kishi'?

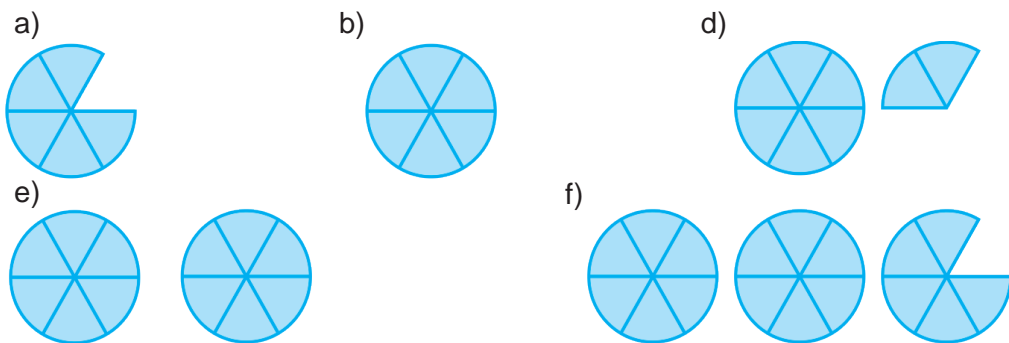

757. Su'wretke qarap AB , CD ha'm EF kesindilerdin' ha'r biri basqalarni'n' qanday bo'legin quraydi':

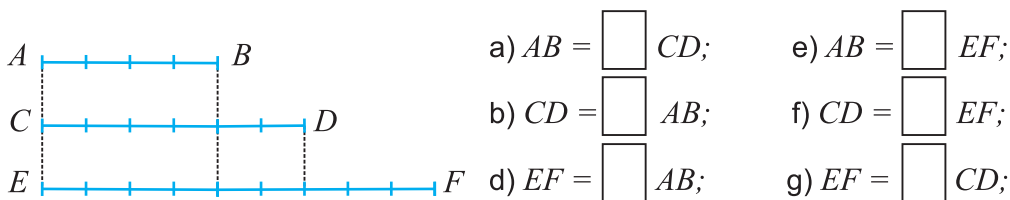

758. Yeger yeki ketekshe 1 di an'lati'p ati'rg'an bolsa, to'mendegi figuralar qanday sandi' an'latadi'?

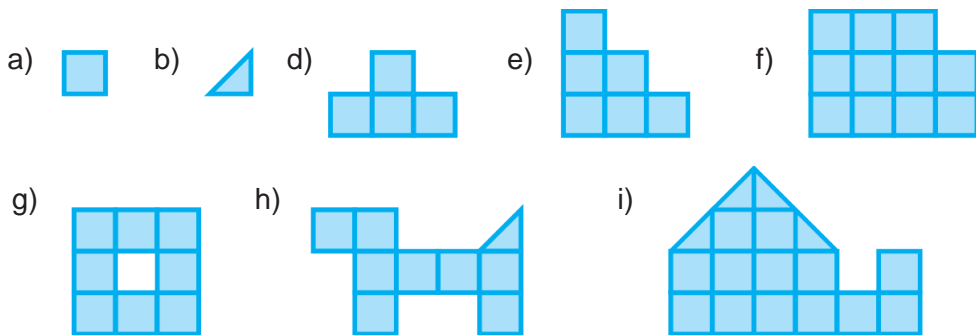

- 759.** Dilnaza 168 betlik tekstin' jetiden to'rt bo'legin kompyuterde terdi. Wol teksttin' neshe betin kompyuterde tergen? Ja'ne neshe betlik tekst qalg'an?
- 760.** Juldi'zshalar worni'na tiyisli u'lken (>) yamasa (<) belgisin qoyi'n':
- a) $\frac{8}{13} * \frac{7}{13}$; b) $\frac{17}{21} * \frac{3}{21}$; d) $\frac{12}{19} * \frac{17}{19}$; e) $\frac{83}{121} * \frac{116}{121}$.
- 761.** c ni'n' qanday ma'nislerinde $\frac{c}{17}$ bo'lshek $\frac{7}{17}$ bo'lshekten u'lken, biraq $\frac{16}{17}$ bo'lshekten kishi boladi'? Bunday bo'lsheklerdin' barli'g'i'n jazi'n'.
- 762.** Su'wretke qarap: a) AB kesindi CD kesindinin'; b) CD kesindi AB kesindinin' qanday bo'legin quraydi'.

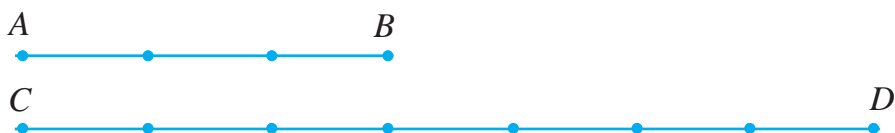

- 763.** Dem ali'w xanasi'ni'n' maydani' 18 m² boli'p, wol imarat maydani'ni'n' $\frac{1}{9}$ bo'legin quraydi'. Imaratti'n' maydani'n tabi'n'.
- 764.** Si'bawshi'lar 6 saatta jumi'sti'n' $\frac{3}{8}$ bo'legin wori'n'ladi'. Jumi's qansha waqi'tta wori'nlanadi'?
- 765.** a) $\frac{5}{9}$ bo'legi 125ke ten'; b) $\frac{7}{12}$ bo'legi 14 ke ten' bolg'an sandi' tabi'n'.
- 766.** Sayaxatshi' 5 ku'n jol basi'p wo'tti. Bul pu'tkil joldi'n' $\frac{1}{5}$ bo'legin quraydi'. Sayaxatshi' ma'nzilge jetip bari'w ushi'n usi' tezlikte qansha ku'n ju'riwi kerek?
- 767.** Yegilgen 2500 qi'yar na'linin' 2300 danasi' wo'sip shi'qti'. Na'ldin' qansha bo'legin wo'sip shi'qpag'an?
- 768.** Qaymaqti'n' $\frac{3}{20}$ bo'legin may quraydi'. 102 kg qaymaqta qansha may bar?
- 769.** Mobil baylani's tarmag'i'na birinshi ji'ldan qala xalqi'ni'n' $\frac{2}{7}$ bo'legi, yekinshi ji'li' bolsa $\frac{3}{7}$ bo'legi qosi'ldi'. Qala xalqi'ni'n' qansha bo'legi mobil baylani's tarmag'i'na qosi'lg'an? Yeger qalada 87 500 adam jasaytug'i'n bolsa, ha'zirde wolardi'n' qanshasi' mobil baylani's xi'zmetinen paydalanbaydi'?
- 770.** Bo'lshekler u'stinde a'mellerdi wori'nlan':
- a) $\frac{5}{12} + \frac{11}{12}$; b) $\frac{55}{86} - \frac{48}{86}$; d) $\frac{254}{391} + \frac{288}{391}$;
- e) $\frac{113}{247} - \frac{79}{247}$; f) $\frac{534}{1613} - \frac{327}{1613}$; g) $\frac{156}{2306} + \frac{1212}{2306}$.

771. Ten'lemeni sheshin':

a) $x - \frac{5}{17} = \frac{10}{17}$; b) $\frac{66}{71} - y = \frac{34}{71}$; || d) $z + \frac{17}{27} = \frac{25}{27}$; e) $\frac{234}{583} + p = \frac{489}{583}$.

772. Ten'lemeni sheshin':

a) $\frac{25}{51} - x = \frac{2}{51} + \frac{3}{51}$; || b) $y - \frac{27}{132} = \frac{129}{132} - \frac{35}{132}$;
d) $z + \frac{12}{45} = \frac{14}{45} + \frac{19}{45}$; || e) $p + \frac{171}{492} = \frac{411}{492} - \frac{116}{492}$.

773. Sandi' naduri's bo'lshek ko'riniside an'lati'n':

a) $5\frac{5}{13}$; || b) $7\frac{7}{39}$; || d) $2\frac{56}{125}$; || e) $14\frac{121}{210}$.

774. Saatta an'lati'n':

a) 2 saat 30 minut; || b) 8 saat 53 minut; || d) 7 saat 32 minut.

775. Kilometrde an'lati'n':

a) 16 km 350 m; || b) 2 km 889 m; || d) 29 km 561 m.

776. Qosi'ndi'ni' tabi'n'.

a) $7\frac{5}{17} + 2\frac{11}{17}$; || b) $6\frac{19}{34} + 4\frac{13}{34}$; || d) $3\frac{5}{26} + 6\frac{6}{26}$; || e) $5\frac{17}{18} + 3\frac{13}{18}$.

777. Da'rya ag'i'mi'ni'n' tezligi $2\frac{7}{9}$ km/saat, qayi'qti'n' turg'an suwdag'i' tezligi bolsa $17\frac{4}{9}$ km/saat. Qayi'qti'n' ag'i'm boylap ha'm ag'i'mg'a qarsi' tezligin tabi'n'.

778. A'mellerdi wori'nlan':

a) $1\frac{15}{17} + 2\frac{6}{17}$; || b) $6\frac{1}{19} - 3\frac{5}{19}$; || d) $8\frac{1}{27} + 15\frac{25}{27}$; || e) $4\frac{5}{18} - 1\frac{7}{18}$.

779. Tuvri'mu'yeshliktin' uzi'nli'g'i' $12\frac{5}{9}$ sm, yeni bolsa wonnan $6\frac{2}{9}$ sm qi'sqa. Tuvri'mu'yeshliktin' yenin tabi'n'.

780. Tuvri'mu'yeshliktin' yeni $5\frac{6}{13}$ dm, uzi'nli'g'i' bolsa $9\frac{7}{13}$ dm. Tuvri'mu'yeshliktin' perimetrin tabi'n'.

Bilimin'izdi si'nap ko'rin'!



Bul bap materialari'n u'yrenip shi'g'i'p, to'mendegi ma'selelerdi sheshe ali'wi'n'i'z sha'rt! Qadag'alaw jumi'si' aldi'nan wo'zin'izdi si'nap ko'rin'!

Test. Duri's juwapti' ani'qlan'.

- Ali'mi' bo'liminen u'lken bo'lshek qanday ataladi'?
A. Duri's bo'lshek; || B. Aralas san; || D. A'piwayi' bo'lshek; || E. Naduri's bo'lshek.
- Naduri's bo'lshektin' ma'nisi haqqi'nda ne ayti'w mu'mkin?
A. 1 den u'lken; || B. 1 den kishi; || D. 1 ge ten'; || E. 0 ge ten'.
- Birdey bo'limge iye yeki bo'lshekten qaysi'si'ni'n' ali'mi' kishi bolsa, sol bo'lshek... boladi'.
A. kishi; || B. u'lken; || D. duri's bo'lshek; || E. naduri's bo'lshek.

8-qadag'alaw jumi's u'lgisi

- A'mellerdi wori'nlan':
 - $\frac{10}{11} - \frac{4}{11} + \frac{3}{11}$; ||
 - $4\frac{5}{9} + 3\frac{8}{9}$; ||
 - $6 - 2\frac{3}{8}$; ||
 - $5\frac{6}{13} - 1\frac{11}{13}$.
- Sayaxatshi' 3 saatta 14 km ju'rdi. Woni'n' tezlugin tabi'n'.
- Garajda 45 avtomobil bar. Wolardi'n $\frac{5}{9}$ bo'legi jen'il avtomobiller. Garajda neshe jen'il avtomobiller bar?
- Ten'lemeni sheshin':
 - $5\frac{6}{7} - x = 3\frac{2}{7}$; ||
 - $y + 4\frac{8}{11} = 10\frac{7}{11}$.
- Qanday sandi' 8 ge bo'lsek, tiyindi $5\frac{7}{8}$ ge ten' boladi'?



Qi'ziqli' matematikag'a tiyisli ma'seleler

Sanli' labirint. Si'rtqi' shen'berde turg'an sanlarga' ishki shen'berde turg'an qaysi' sandi' qossa, woraydag'i' san payda boladi'?

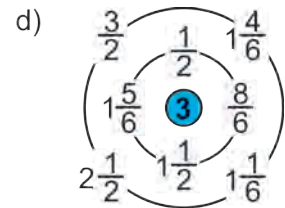
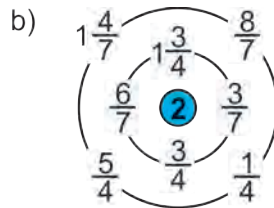
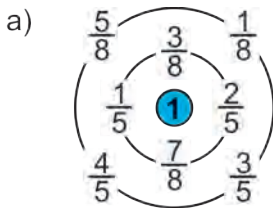

Matematika tarixi'na tiyisli u'zindiler

Yeski Axmes ma'seleli

Misrdan tabi'lg'an papirus qag'azi'nda bunnan mi'n' ji'llar aldi'n jasag'an Axmestini' matematikag'a, a'sirese, bo'lsheklerge tiyisli ko'pg'ana ma'seleleri keltirilgen.

Mine wolardan biri: 7 nandi' 8 adamg'a ten' bo'lip berin'.

Ju'da' an'sat ma'sele yeken-g'oy, dewin'iz m'umkin. Haqi'yqattan da, ha'r bir mandi' 8 bo'lekke bo'lip, ha'r bir adamg'a 7ewden u'les berip, ma'seleni sheshiw mu'mkin.

Biraq, ha'mme ga'p sonda, yeski Mi'si'rli'lar nandi' imkani' bari'nsha kem bo'leklerge bo'lip, bul ma'seleni sheshken. Siz de bul sheshimdi tabi'wg'a uri'ni'p ko'rin'!

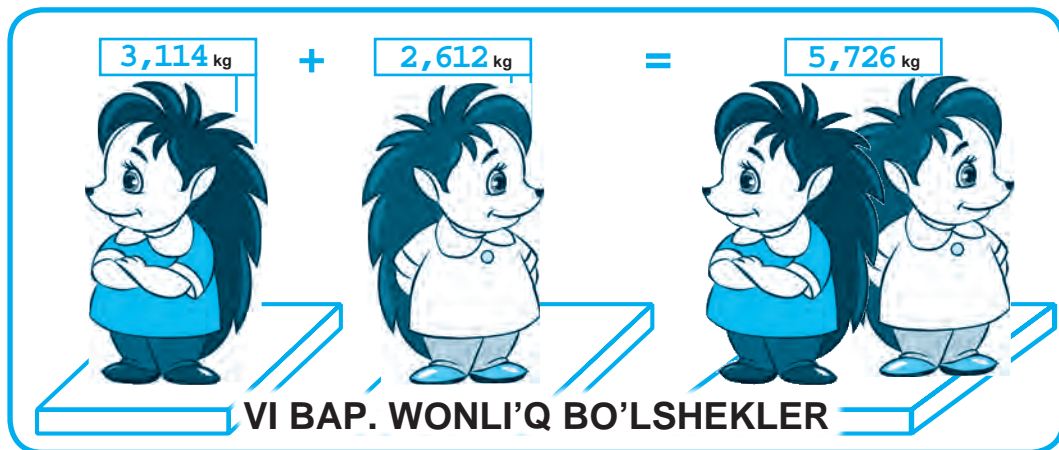

35- §.

WONLI'Q BO'LSHEKLERDIN' JAZI'LI'WI' HA'M WOQI'LI'WI'

Sunday bo'lshek sanlar bar, wolar u'stinde a'mellerdi tap natural sanlardag'i'day an'sat wori'nlaw mu'mkin. Bul bo'lshekler bo'limi 10, 100, 1000 ha'm tag'i' basqa sanlardan ibarat bolg'an sanlar. Bunday bo'lshekler *wonli'q bo'lshekler* dep ataladi'. Bul bapta wonli'q bo'lsheklerdin' jazi'li'wi' ha'm wolar u'stinde a'meller qalay wori'nlani'wi' haqqi'nda toqta'p wo'temiz.

1- mi'sal. 8 m 52 sm metrde an'latayi'q.

$$1 \text{ sm} = \frac{1}{100} \text{ m bolg'ani' ushi'n, } 52 \text{ sm} = \frac{52}{100} \text{ m boladi'.$$

$$\text{Bul jag'dayda, } 8 \text{ m } 52 \text{ sm} = 8 \text{ m} + 52 \text{ sm} = 8 \text{ m} + \frac{52}{100} \text{ m} = 8\frac{52}{100} \text{ m.}$$

$$\text{Yekinshi ta'repten, } 8 \text{ m } 52 \text{ sm} = 8 \text{ m} + 50 \text{ sm} + 2 \text{ sm} =$$

$$= 8 \text{ m} + 5 \text{ dm} + 2 \text{ sm} = 8 \text{ m} + \frac{5}{10} \text{ m} + \frac{2}{100} \text{ m.}$$

$8\frac{52}{100}$ bo'lshek u'tir ja'rdeminde bo'limisiz **8,52** ko'riniside jazi'ladi' ha'm *8 pu'tin ju'zden 52* dep woqi'ladi'. Demek,

$$8\frac{52}{100} \text{ m} = 8,52 \text{ m}$$

Bul jazi'wda u'tirdin' shep ta'repinde 8 sani' turi'pti'. Wol pu'tin metrler sani'n ko'rsetedi. U'tirdin' won' ta'repinen birinshi wori'nda turg'an 5 Cifri' – metrdin' wonnan bir u'lesleri yag'ni'y detsimetrler sani'n, yekinshi wori'nda turg'an 2 Cifri' bolsa metrdin' ju'zden bir u'lesleri, yag'ni'y santimetrler sani'n ko'rsetedi. Ko'rip turg'ani'n'i'zday bul jazi'w natural sanlardin' wonli'q jazi'wi'na ju'da' uqsap ketedi: ha'rbir xana birligi shepten wong'a qarap wo'zinen aldi'n kelgen xana birliginen 10 ma'rte kishi.

8,52 jazi'w $8\frac{52}{100}$ *bo'lshek sani'ni'n' wonli'q ko'rinisidegi an'latpasi'* yamasa *wonli'q bo'lshek* dep ataladi'.

2- misol. 4 kg 565 g di' kilogrammda an'latayiq:

$$4 \text{ kg } 565 \text{ g} = 4 \text{ kg} + 565 \text{ g} = 4 \text{ kg} + \frac{565}{1000} \text{ kg} = 4 \frac{565}{1000} \text{ kg}$$

ke yekenligin tabami'z.

$8\frac{3}{10}$ sani'ni'n' bo'lshek bo'legi bo'limi 10 ga, $8\frac{52}{100}$ sani'ni'n' bo'lshek bo'legi bo'limi 100 ge, $4\frac{565}{1000}$ sani'ni'n' bo'lshek bo'legi bo'limi bolsa 1000 g'a ten'.



Bo'limi 10, 100, 1000 ha'm basqada bolg'an sanlardi' (bo'limsiz) wonli'q bo'lshek ko'riniside to'mendegishe jazi'wg'a kelisip ali'ng'an:

- aldi'n sanni'n' pu'tin bo'legi jazi'ladi';
- son' bo'lshek bo'leginin' ali'mi' jazi'ladi' ha'm wolar bir-birinen u'tir arqali' aji'rati'ladi.

Maselen, $8\frac{3}{10}$ sani' 8,3 ko'riniside jazi'ladi' ha'm «8 pu'tin wonnan 3» dep, $4\frac{565}{1000}$ sani' bolsa 4,565 ko'riniside jazi'ladi' ha'm «4 pu'tin mi'n'nan 565» dep woqi'ladi'.

Solay yetip, $8 \text{ dm } 3 \text{ sm} = 8\frac{3}{10} \text{ dm} = 8,3 \text{ dm};$

$$4 \text{ kg } 565 \text{ g} = 4\frac{565}{1000} \text{ kg} = 4,565 \text{ kg}.$$



Bo'lshek bo'leginin' bo'limi 10, 100, 1000 ha'm basqa bolg'an ha'r qanday sandi' wonli'q bo'lshek ko'riniside an'latiw mu'mkin.

Yeger bo'lshek duri's bo'lshek bolsa, woni'n' wonli'q jazi'wi'nda pu'tin bo'legi 0 dep ali'nadi'.

Ma'selen, $\frac{35}{100}$ sani' – duri's bo'lshek. Bul bo'lshek 0,35 ko'riniside jazi'ladi' ha'm «0 pu'tin ju'zden 35» dep woqiladi. Demek, $\frac{35}{100} = 0,35$.



Wonli'q ko'riniside jazi'lip at'rg'an sanni'n' bo'lshek bo'legi bo'liminde neshe nol bolsa, ali'mda da, u'tirden keyin de sonsha san boli'wi' kerak.

Ma'selen, $5\frac{67}{1000}$ sani'ni'n' bo'lshek bo'legi ali'mi'nda yeki tsifr, bo'liminde bolsa u'sh nol bar. Soni'n' ushi'n aldi'n ali'm aldi'na bir nol qoyi'p, woni' $5\frac{067}{1000}$ tu'rinde jazi'p alami'z. Son' woni' 5,067 wonli'q bo'lshek ko'riniside an'latami'z ha'm «5 butun mingdan 67» dep oqi'yimi'z. Sog'an uqsas, $3\frac{7}{1000} = 3\frac{007}{1000} = 3,007$.



Sorawlarg'a juwap berin'

1. Qanday sanlardi' wonli'q bo'lshek ko'riniside jazi'w mu'mkin?
2. Sanlardi' wonli'q ko'riniside jazi'wdi'n' qanday abzalli'qlari' bar?
3. Wonli'q bo'lshektin' pu'tin ha'm bo'lshek bo'legi ne menen aji'rati'ladi'?

Klasta wori'nanatug'i'n shi'ni'g'i'wlar



781. Sanni'n' pu'tin ha'm bo'lshek bo'legin ayti'n':

- a) $4\frac{7}{10}$; || b) $27\frac{28}{1000}$; || d) $\frac{78}{100}$; || e) $5\frac{3}{10}$; || f) $35\frac{92}{1000}$; || g) $4\frac{332}{10\ 000}$.

782. Wonli'q bo'lsheklerdi woqi'n':

- a) 3,6; 12,5; 392,3; 77,7; 1,8; 0,9;
 b) 6,43; 38,17; 983,50; 3,910; 0,47; 0,13;
 d) 6,181; 0,018; 314,403; 5,0304; 0,2006; 0,01001.

783. (Matematika'li'q diktant) Wonli'q bo'lshek ko'riniside jazi'n':

Won u'sh pu'tin wonnan bir; nol pu'tin ju'zden qi'rq to'rt; bes pu'tin ju'zden bir; jigirma bir pu'tin mi'n'nan won segiz; u'sh pu'tin mi'n'nan bir ju'z alpi's bir; nol pu'tin mi'n'nan seksen bir; nol pu'tin won mi'n'nan yeki ju'z yeliw yeki.

784. A'piwayi' bo'lshekli wonli'q bo'lshek ko'riniside jazi'n' ha'm woqi'n'.

- a) $4\frac{7}{10}$; || b) $7\frac{318}{1000}$; || d) $\frac{67}{100}$; || e) $\frac{3}{10}$; || f) $3\frac{9}{100}$; || g) $14\frac{433}{10\ 000}$.

U'lgi: $3\frac{23}{100} = 3,23$; $7\frac{46}{1000} = 7\frac{046}{1000} = 7,046$.

785. Sanni'n' pu'tin ha'm bo'lshek bo'leklerin aji'rati'n' ha'm wonli'q bo'lshek ko'riniside jazi'n':

- a) $\frac{76}{10}$; || b) $\frac{7318}{1000}$; || d) $\frac{6721}{100}$; || e) $\frac{343}{10}$; || f) $\frac{9907}{100}$; || g) $\frac{33\ 000}{10\ 000}$.

786. A'piwayi' bo'lshek yamasa aralas san ko'riniside an'lati'n':

- a) 3,14; || b) 10,8; || d) 443,91; || e) 7,008; || f) 0,91; || g) 0,03.

U'lgi: $25,09 = 25 + \frac{9}{100} = 25\frac{9}{100}$.

787. Tiyindini wonli'q bo'lshek ko'riniside jazi'n':

- a) $435 : 10$; || b) $9803 : 100$; || d) $149 : 10000$; || e) $27 : 1000$.

U'lgi: $573 : 100 = \frac{573}{100} = 5\frac{73}{100} = 5,73$.



788. To'mendegi sxema tiykari'nda sorawlarg'a juwap berin':



- a) 1 millimetr detsimetrdin'; b) 1 millimetr metrdin'; d) 1 santimetr kilometrdin';
 e) 1 metr kilometrdin' qand ay bo'legin quraydi'?

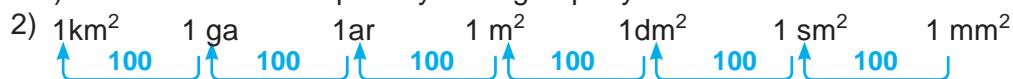

- a) 1 mm² santimetr kvadratti'n'; b) 1 sm² metr kvadratti'n';
 d) 1 dm² kilometr kvadratti'n'; e) 1 dm² ardi'n';
 f) 1 ar kilometr kvadratti'n' qanday bo'legin quraydi'?



- a) 1 g sentnerdin'; b) 1 kg tonnani'n' qanday bo'legin quraydi'?

789. Metr ha'm santimetrlerde an'lati'n': a) 6,13 m; b) 16,01 m; d) 7,10 m.

U'lg'i: $56,65 \text{ m} = 56 \text{ m} + \frac{65}{100} \text{ m} = 56 \text{ m } 65 \text{ sm.}$

790. 1) Kilogrammda an'lati'n' ha'm wonli'q bo'lshek ko'rinishide jazi'n':

- a) 5 kg 813 g; b) 457 g; d) 2307 g; e) 7 kg 97 g; f) 1 kg 2 g; g) 14 835 g.

U'lg'i: $73 \text{ kg } 278 \text{ g} = 73 \text{ kg} + \frac{278}{1000} \text{ kg} = 73 \frac{278}{1000} \text{ kg} = 73,278 \text{ kg.}$

- 2) Tonna ha'm kilogrammlarda an'lati'n': a) 2,783 t; b) 45,01 t; d) 25,019 t.

U'lg'i: $6,54 \text{ t} = 6,540 \text{ t} = 6 \text{ t} + \frac{540}{1000} \text{ t} = 6 \text{ t } 540 \text{ kg.}$

- 3) Swmda an'lati'n' ha'm wonli'q bo'lshek ko'rinishide jazi'n':

- a) 14 swm 58 tiyin; b) 5 swm 7 tiyin; d) 403 tiyin; e) 1438 tiyin.

U'lg'i: $34 \text{ swm } 45 \text{ tiyin} = 34 \text{ swm} + \frac{45}{100} \text{ swm} = 34,45 \text{ swm.}$



U'yde wori'nlantug'i'n shi'ni'g'i'wlar

791. Wonli'q bo'lshek ko'rinishide jazi'n':

- a) $3 \frac{9}{10}$; || b) $\frac{674}{1000}$; || d) $\frac{35}{100}$; || e) $8 \frac{7}{100}$; || f) $7 \frac{48}{10\ 000}$; || g) $2 \frac{889}{10\ 000}$.

792. Wonli'q bo'lshek ko'rinishide jazi'n':

won pu'tin wonnan yeki; nol pu'tin mi'n'nan bir ju'z yeliw to'rt; al ti' pu'tin ju'zden u'sh; alti' pu'tin mi'n'nan yeki ju'z bir; nol pu'tin mi'n'nan won yeki; won pu'tin mi'n'nan jeti ju'z toqsan.

793. Tiyindini wonli'q bo'lshek ko'rinishide jazi'n':

- a) 385:10; || b) 8503:100; || d) 491:10 000; || e) 75:1000; || f) 783:1000; || g) 9:10000.



794. Metrde an'lati'n' ha'm wonli'q bo'lshek ko'rinishide jazi'n': a) 34 dm; b) 78 sm; d) 301 sm; e) 17 mm; f) 43 m 1 sm; g) 9 sm 2 mm; i) 4 dm 9 mm.

795. Kvadrat metrde an'lati'n':

- a) $7 \text{ m}^2 \text{ } 61 \text{ dm}^2$; || b) 633 dm^2 ; || d) $25 \text{ m}^2 \text{ } 80 \text{ dm}^2$; || e) $32 \text{ m}^2 \text{ } 1 \text{ dm}^2$.

796. Aralari'ndag'i' arali'q 19 km 500 m bolg'an yeki punktten bir waqi'tta bir qi'yli' jo'neliste 12 km/saat tezlik penen velosipedshi ha'm 90 km/saat tezlik penen jen'il avtomobil jolg'a shi'qti'. Jen'il avtomobil qansha waqi'ttan keyin velosipedshini quwi'p jetedi?

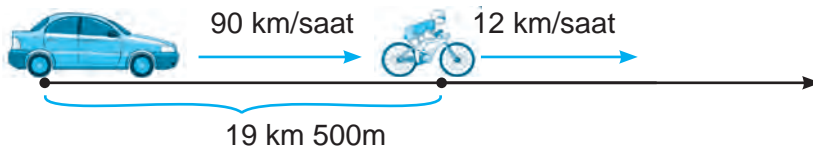

797. U'sh ku'nde du'kanda ja'mi 1 971 500 swmli'q sawda islendi. Yeger birinshi ku'ni yekinshi ku'nge qarag'anda 23 500 swm ko'p, u'shinshi ku'ni bolsa birinshi ku'nge qarag'anda 56 000 swm kaz sawda islengen bolsa, bul du'kanda ha'r qaysi' ku'nde qansha sawda qi'li'ng'an?

Matematika tariyxi'na tiyisli u'zindiler



Wonli'q bo'lshekler u'stinde a'meller wori'nlaw qag'i'ydalari'n XV a'sir basi'nda Samarqandtag'i' Ulug'bek mektebinin' ataqli' ali'mi'. Shi'g'i'sti'n' ulli' matematik ali'mi' Jamshid G'iyosiddin al-Koshiy (1385-1430) wo'zinin', "Muftoh al-hisob" ("Esap iliminin' gilti") dep atalg'an miynetinde bayan yetilgen. Al-Koshiy wonli'q bo'lshekli ha'zirde qabi'l yetilgen ko'riniste belgilegen. Tek g'ana wol u'tirden paydalanbag'an. Sanni'n' bo'lshek bo'legin qi'zi'l ren'de jazg'an ya'ki tik tayaqsha menen pu'tin bo'leginen aji'ratqan.

Bul haqqi'nda evropali'lar xabarsi'z bolg'an. Evropag'a wonli'q bo'lshekler 150 ji'ldan keyin kirip kelgen. Niderlandiyali' injener ha'm ali'm Simon Stiven wonli'q bo'lshekler jazi'wi'n qaytadan payda etken. Biraq Stiven wonli'q bo'lsheklerdi qi'yin tu'rde belgilegen. XVII a'sirge kelip wonli'q bo'lshekler ha'zirgi ko'riniside qollani'la baslag'an.

Qi'ziqli' matematikag'a tiyisli ma'seleler



Paydali' yermek. Avtobusta ketip barati'ri'p uzaq joldi' qanday jaqi'n qi'li'w mu'mkin? Bul – ju'da' an'sat. Bir paydali' jumi's penen ba'nt bolsan'i'z ma'nzilin'izge jetip kelgenin'izdi de bilmey qalasi'z. Mine, usi' yermeklerden biri:

Avtobus biletine jazi'lg'an cifrlardi'n' worni'n wo'zgartirmey, qawsir'malar ha'm to'rt arifmetikali'q a'mellerden paydalani'p 100 (yamasa wog'an yen' jaqi'n) sani'n payda yetin'.

Ma'selen, bilette alti' cifrdan ibarat 136091 sani' jazi'lg'an bolsi'n. Wonnan cifrlar worni'n wo'zgartpegen halda, qawsir'malar ha'm to'rt arifmetikali'q a'mellerden paydalani'p to'mendegi 100 sanni'n payda yetiw mu'mkin:

$$1 \cdot 3 + 6 + 0 + 91 = 100, \quad (1 + 3 + 6 + 0) \cdot (9 + 1).$$

100 di ja'ne basqa qanday usi'llar menen payda yetiw mu'mkin?

36- §.

WONLIQ BO'LSHEKLERDI' SALISTIRIW

Uzi'ni'g'i' 8 sm, yag'ni'y 80 mm bolg'an AB kesindi berilgen bolsi'n. Bul kesindi uzi'ni'g'i'ni'n' ha'r bir wo'lshechin detsimetrlerde an'lati'n'.

$$1 \text{ sm} = \frac{1}{10} \text{ dm ha'm } 8 \text{ sm} = \frac{8}{10} \text{ dm bolg'ani' ushi'n } AB = 0,8 \text{ dm boladi'}$$

$$1 \text{ mm} = \frac{1}{100} \text{ dm ha'm } 80 \text{ mm} = \frac{80}{100} \text{ dm bolg'ani' ushi'n } AB = 0,80 \text{ dm boladi'}$$

Demek, $AB = 0,8 \text{ dm} = 0,80 \text{ dm}$.

Juwmaq: 0,8 ha'm 0,80 bo'lshekler bir-birine ten': $0,8 = 0,80$



Yeger onli'q bo'lshek won' ta'repine turg'an nol ali'p taslansa, ya'ki bo'lshektin' won' ta'repine noller jazi'lsa, berilgen bo'lshekke ten' bo'lshek payda boladi'.

Ma'selen,

$$\begin{array}{l} 0,43 = 0,430 = 0,4300; \quad || \quad 6,7 = 6,70 = 6,700; \quad || \quad 18 = 18,0 = 18,000; \\ 0,900 = 0,90 = 0,9; \quad || \quad 43,200 = 43,20 = 43,2; \quad || \quad 31,00 = 31,0 = 31. \end{array}$$

1- mi'sal. 4,54 ha'm 6,9 wonli'q bo'lsheklerdi wo'z ara sali'sti'rayi'q.

Aldi'n wolardi'n' u'tirden keyingi wonli'q cifrlar sani'n ten'lestiremiz. Buni'n' ushi'n 6,9 bo'lshektin' won' ta'repine bir nol jazami'z: 4,54 ha'm 6,90 bo'lsheklerdi payda yetemiz. Wolardi' naduri's bo'lshek ko'rinishinde an'latami'z:

$$4,54 = 4 \frac{54}{100} = \frac{454}{100}, \quad || \quad 6,90 = 6 \frac{90}{100} = \frac{690}{100}.$$

Bul bo'lsheklerdin' bo'limleri bir qi'yli'.

Demek, wolardan qaysi' birinin' ali'mi' u'lken bolsa, sol bo'lshek u'lken boladi':

$$454 < 690 \quad \text{bolg'ani' ushi'n} \quad \frac{454}{100} < \frac{690}{100}.$$

Demek, $4,54 < 6,90$, yag'ni'y $4,54 < 6,9$.



Yeki wonli'q bo'lshekti wo'z ara sali'sti'ri'w ushi'n:

- aldi'n wolardan birinin' won' ta'repine noller jazi'p, wolardi'n' u'tirden keyingi tsifrlar sani' ten'lestiriledi;
- son' u'tirler tu'sirip qaldi'ri'lg'an ha'm payda bolg'an natural sanlar wo'z ara sali'sti'ri'ladi'.

2- mi'sal. 23,54 ha'm 16,9 sanlari'n sali'sti'rayi'q.

1. Sanlardi'n' u'tirden keyingi cifrlar sani'n ten'lestiremiz: 23,54 ha'm 16,90;

2. U'tirlerdi tu'sirip qaldi'rami'z ha'm sanlardi' sali'sti'rami'z: $2354 > 1690$;

Demek, $23,54 > 16,9$.

36.2. Wonli'q bo'lsheklerdi sanlar nuri'nda su'wretlew

Wonli'q bo'lsheklerdi tap a'piwayi' bo'lshekler si'yaqli' sanlar nuri'nda su'wretlew mu'mkin.

3- misol. 0,3 wonli'q bo'lshekli sanlar nuri'nda ko'rseteyik.

Buni'n' ushi'n:

- aldi'n woni' a'piwayi' bo'lshek ko'riniside an'latami'z: $0,3 = \frac{3}{10}$;
- son' birlik kesindini 10 ten' bo'lekke bo'lip, shep ta'repten bul bo'leklerden u'shewin sanaymi'z ha'm $A(0,3)$ noqati'n belgileymiz.

Bul noqat – 0,3 wonli'q bo'lshekli sanlar nuri'ndagi'i ko'rinisi boladi' (1-su'wret).

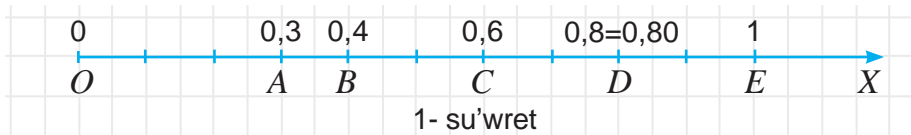

Sanlar nuri'nda ten' wonli'q bo'lshekler bir noqat penen su'wretlenedi. 

Ma'selen, 0,8 ha'm 0,80 ten' bo'lshekler bir g'ana D noqat penen su'wretlenedi.

Sanlar nuri'nda u'lken wonli'q bo'lshek kishisinen won'da, kishi wonli'q bo'lshek bolsa u'lkeninen shepte jatadi'. 

Ma'selen, $0,3 < 0,4 < 0,6$. Soni'n' ushi'n sanlar nuri'nda $B(0,4)$ noqati' $A(0,3)$ noqati'nan won'da, $C(0,6)$ noqati'nan bolsa shepte jatadi' (1-su'wret).

Sorawlarg'a juwap berin' 

1. Yeger wonli'q bo'lshekli won' ta'repide noller jazi'lsa qanday bo'lshek payda boladi'?
2. Yeger wonli'q bo'lshekli won' ta'repide turg'an nol tu'sirilip qaldi'ri'lsa, bo'lshek wo'zgereme?
3. Wonli'q bo'lsheklerdi sali'sti'ri'w ni'zami'n tu'sindirip berin'.
4. Sanlar nuri'nda wonli'q bo'lshekler qalay su'wretlenedi?
5. Sanlar nuri'nda su'wretlengen bo'lsheklerdin' bir-birinen u'lken ya'ki kishi yekenligin qalay ani'qlaw mu'mkin?

Klasta wori'nlanatug'i'n shi'ni'g'i'wlar 

798. Sonday wonli'q bo'lshek jazi'n', wol: a) 0,95 ke ten' ha'm u'tirden keyin 4 cifri' bar bolsi' n; b) 195 ke ten' ha'm u'tirden keyin 3 cifri' bar bolsi'n; d) 6,300000 g'a ten' ha'm u'tirden keyin 3 cifri' bar b olsi'n.

799. Ha'r bir qatardagi'i wo'z ara ten' sanlardi' tabi'n':

- a) 0,8; 0,08; 0,80; 0,008; 0,8000; 0,0008;
b) 5,1; 5,01; 5,010; 5,001; 5,01000; 5,00010.

800. Sanlardi' sali'sti'ri'n':

- a) 85,09 ha'm 67,99; b) 55,7 ha'm 55,7000; d) 0,908 ha'm 0,918;
e) 7,6431 ha'm 7,6429; f) 0,5 ha'm 0,724; g) 0,0025 ha'm 0,00247.

U'lgi: Joqari'da ko'rilgen 1- ha'm 2- mi'sal.

801. a) 3,456; 3,465; 8,149; 8,079; 0,453; 0,4532 sanlardi' wo'siw ta'rtibinde;
b) 0,456; 0,065; 0,009; 0,079; 0,0093; 0,0502 sanlardi' kemeyiw ta'rtibinde jaylasti'ri'n'.

802. Da'pterin'izge si'zi'lmani' ko'shirin'. Ha'r bir si'zi'qqa sa'ykes wonli'q bo'lshekti jazi'n'.

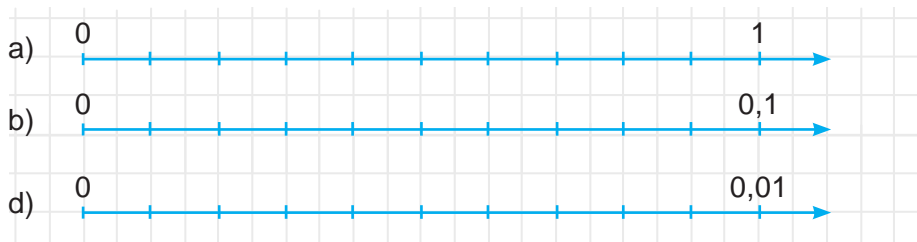

803. Da'pterdin' 10 keteshe uzi'nli'g'i'n birlik kesindi si'pati'nda ali'p, sanlar nuri'nda $A(0,2)$, $B(0,6)$, $C(0,8)$, $D(1,3)$ ha'm $F(1,5)$ noqatlari'n belgilen'.

804. Noqatlardan qaysi' biri sanlar nuri'nda solda joylasqan?



a) $A(1,3)$ ya'ki $B(1,8)$; b) $C(0,33)$ ya'ki $D(0,37)$; d) $E(5,5)$ ya'ki $F(5,45)$.

805. Shamalardi' sali'sti'ri'n'::

- | | |
|---------------------------------|---|
| a) 324,17 kg ha'm 320,78 kg; | f) 1,2 t ha'm 1643,3 kg; |
| b) 98,52 m ha'm 65,39 m; | g) 1272 m ha'm 13,888 km; |
| d) 23,5°C ha'm 13,59°C; | h) 7772,45 a ha'm 7,77248 ga; |
| e) 21,289 saat ha'm 21,29 saat; | l) 32,143 litr ha'm 32149 sm ³ . |

U'ligi: 5,78 kg ha'm 3,79 kg. U'tirlerdi tu'sirip qaldi'rami'z ha'm natural sanlardi' sali'sti'rami'z: $5,78 > 3,79$. Demek, $5,78 \text{ kg} > 3,79 \text{ kg}$.

806. Wonli'q bo'lsheklerdi sali'sti'ri'n' ha'm na'tiyjeni ten'sizlik ko'riniside jazi'n':

- | | | |
|----------------------|----------------------|-----------------------|
| a) 18,22 ha'm 5,75; | b) 3,50 ha'm 3,6; | d) 0,76 ha'm 0,8; |
| e) 0,1009 ha'm 0,19; | f) 99,22 ha'm 100,9; | g) 0,230 ha'm 0,2310. |

807. To'mendegi wonli'q bo'lshekler arasi'nda joylasqan natural sanlardi' jazi'n':

- | | | |
|-------------------------|-------------------------|------------------------|
| a) 0,9 ha'm 3,41; | b) 4,53 va 13,4; | d) 56,456 ha'm 65,609; |
| e) 209,67 ha'm 213, 03; | f) 3007,4 ha'm 3010,01; | g) 28,13 ha'm 34,09. |

808. Onli'q bo'lsheklerdi aldi'n wo'siw, keyin kemeyiw ta'rtibinde jaylasti'ri'n':

- | | | | | | | |
|-----------|-------|--------|--------|--------|---------|--------|
| a) 1,708; | 0,98; | 4,708; | 13,2; | 7,613; | 0,99; | 1,123; |
| b) 0,02; | 3,02; | 0,302; | 0,022; | 0,202; | 0,0302; | 20,3. |

809. Ten'sizlikni tekserin'.

- a) $2 > 1,75$; || b) $18,006 < 19,0001$; || d) $71,2 > 71,2005$; || e) $24,009 < 23,999$.



U'yde wori'nlanatug'i'n shi'ni'g'i'wlar

810. 2,47; 3,8; 0,0703 ha'm 231,808 wonli'q bo'lsheklerinin' won' ta'repine noller jazi'p, wolardi'n' u'tirden keyingi cifrlar sani'n ten'lestirin'.

811. Sanlardi' sali'sti'ri'n':

- | | | |
|------------------------|--------------------------|----------------------|
| a) 57,99 ha'm 58,01; | d) 1129,9 ha'm 1130, 01; | f) 91,39 ha'm 91,4; |
| b) 60,529 ha'm 60,530; | e) 34,890 ha'm 34,891; | g) 124,5 va 124,501. |

812. Ha'r bir si'zi'lmada 0,5842 sani'n belgilen':



813. Da'pterdin' 10 ketekshe uzi'nli'g'i'n birlik kesindi si'pati'nda ali'p, sanlar nuri'nda $A(0,1)$; $B(0,3)$; $C(1,2)$ ha'm $D(1,8)$ noqatlari'n belgilen'.



814. Noqatlardi'n' qaysi' biri sanlar nuri'nda won'da jaylasqan?

a) $A(2,1)$ yamasa $B(2,3)$; || b) $C(10,5)$ yamasa $D(10,509)$.

815. Duri's ten'sizlik payda yetiw ushi'n ketekshe worni'na qoyi'w mu'mkin bolg'an barli'q cifrlardi' tabi'n':

a) $0, \square 3 > 0,13$; || b) $0,1 \square < 0,18$; || d) $5,64 > 5, \square 8$; || e) $3,51 < 3, \square 1$.

816. Aralari'ndag'i' arali'q 782 km bolg'an yeki qaladan yeki poezd bir-birine qarap tu'rli waqi'tta jolg'a shi'qti'. Birinshi poezd 52 km/saat, yekinshisi 61 km/saat tezlik penen ju'rdi. Birinshi poezd 416 km ju'rgennen keyin yekinshisi menen ushrasti'?

Poezdlardi'n' biri yekinshisinen neshe saat aldi'n jolg 'a shi'qqan?

817. A'mellerdi wori'nlan':

a) $79348 - 64 \cdot 84 : 28 + 653900 : 130$;

b) $108150 : 525 + 24 \cdot (10000 - 24 \cdot 303) - 23598$.

818. Watani'mi'z a'yyemgi yesteliklerge bay. To'mendegi su'wretlerde respublikami'zdi'n' tu'rli walayatlardag'i' minaralar keltirilgen:

a) Xi'ywa qalasi'ndag'i' l'slam Xoja minarasi', biyikligi – 44,5 m;

b) Vobkent minarasi', biyikligi – 39 m;

d) Jarqorg'an minarasi', biyikligi – 21,6 m;

e) Tashkent qalasi'ndag'i' Ha'zireti l'ymam medrese minaralari', biyikligi – 59 m;

f) Xi'ywa qalasi'ndag'i' Kelte minar, biyikligi – 28 m;

g) Buxara qalasi'ndag'i' Minaroi-Kalon, biyikligi – 45,5 m.

Bul minaralardi'n' biyikliklerin kemeyiw ta'tibinde jaylasti'ri'n'.

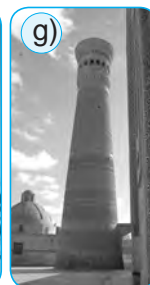

37-§

WONLI'Q BO'LSHEKLERDI QOSI'W HA'M ALI'W

1- mi'sal. 4,5 ha'm 1,451 wonli'q bo'lsheklardi qosayi'q.

Aldi'n wolardi'n' u'tirden keyingi Cifrlar sani'n ten'lestiremiz. Buni'n' ushi'n wolardan birinshisini'n won' ta'repine yeki nol jazami'z: $4,5 = 4,500$.

Son' wolardi' aralas san ko'riniside jazami'z ha'm qosami'z:

$$4,500 = 4 \frac{500}{1000}, \quad 1,451 = 1 \frac{451}{1000},$$

$$4,5 + 1,451 = 4 \frac{500}{1000} + 1 \frac{451}{1000} = 5 \frac{500 + 451}{1000} = 5 \frac{951}{1000} = 5,951.$$

$$\begin{array}{r} 4,500 \\ + 1,451 \\ \hline 5,951 \end{array}$$

Demek, 4,5 ha'm 1,451 wonli'q bo'lsheklardin' qosi'ndi'si 5,951 ge ten'.

Bul na'tiyjeni wonli'q bo'lsheklardi "bag'ana" ko'riniside qosi'p ta payda yetiw mu'mkin (1-su'wret).

2- mi'sal. Yendi usi' sanlardi'n' ayi'rmasi'n da tabayi'q:

$$4,5 - 1,451 = 4 \frac{500}{1000} - 1 \frac{451}{1000} = 3 \frac{500 - 451}{1000} = 3 \frac{49}{1000} = 3,049.$$

$$\begin{array}{r} 4,500 \\ - 1,451 \\ \hline 3,049 \end{array}$$

Bul jag'dayda da na'tiyjeni wonli'q bo'lsheklardi "bag'ana" ko'riniside ali'p, qolayli' usi'lda tabi'wi'n'i'z mu'mkin (2-su'wret).

1- su'wret

2- su'wret



Wonli'q bo'lsheklardi qosi'w (ali'w) ushi'n:

- aldi'n wolardi'n' u'tirden keyingi cifrlar sani' noller menen ten'lestiriledi;
- son' wolar "bag'ana" yetip u'tir u'tirdin' asti'na tu'setug'i'nday yetip jazi'ladi';
- u'tirge itibar bermesten qosi'w (ali'w) wori'nlanadi';
- payda bolg'an sang'a u'stindeg'i wonli'q bo'lsheklardin' u'tirleri asti'na tu'setug'i'n yetip u'tir qoyiladi'.

Ayti'w lazi'm, wonli'q bo'lsheklardi wolardi'n' u'tirden keyingi cifrlari'n noller menen ten'lestirilmestende qosi'w ha'm ali'w mu'mkin. Bul jag'dayda noller jazi'lmasa da wolar bos wori'nlarda turi'pti' dep is ko'riledi.

3- mi'sal. 0,666 wonli'q bo'lshekti to'mendegi qosi'ndi' ko'riniside an'lati'w mu'mkin: $0,666 = 0,600 + 0,060 + 0,006 = 0,6 + 0,06 + 0,006$.

Ko'rinip turi'pti', bul bo'lshek wonnan 6, ju'zden 6 ha'm mi'n'nan 6 lar qosi'ndi'si'nan ibarat.

$0,666 = 0,6 + 0,06 + 0,006$ jazi'w 0,666 *sani'ni'n' xana birlikleri boyi'nsha jayi'p jazi'li'wi' ya'ki qosi'li'wshi'lari' boyi'nsha qosi'ndi'si'* dep ataladi'.

Solay yetip, 0,666 wonli'q bo'lshektin' u'tirden keyingi birinshi 6 cifri – wonnan birler sani', yekinshisi 6 cifri – ju'zden birler sani' ha'm u'shinshi 6 cifri' bolsa mi'n'nan birler sani'n ko'rsetedi. Bo'lshektin' wonli'q jazi'wi'nda u'tirden keyingi:

- birinshi xana – *wonnan birler xanasi'*;
- yekinshi xana – *ju'zden birler xanasi'*;
- u'shinshi xana – *mi'n'nan birler xanasi'* deb ataladi va hokazo.

4- mi'sal. 346,675 bo'lshekti xana birlikleri boyi'nsha jayayi'q.

4- mi'sal. 346,675 bo'lshekti xana birlikleri boyi'nsha jayayi'q.

Woni'n' pu'tin bo'legin ju'zlik, wonli'q ha'm birlik xanasi'nan, bo'lshek bo'legi bolsa wonnan birlik, ju'zden birlik ha'm mi'n'nan birlik xanasi'nan ibarat:

$$346,675 = 300 + 40 + 6 + 0,6 + 0,07 + 0,005.$$

Bul sanni'n' jayi'p jazi'li'wi' 3 ju'zlik, 4 wonli'q, 6 birlik, 6 wonnan birlik, 7 ju'zden birlik ha'm 5 mi'n'nan birlik qosi'ndi'si'nan ibarat.

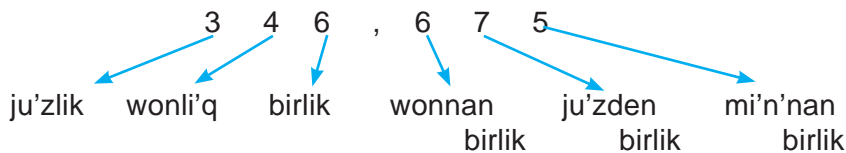

Wonli'q bo'lshektin' xana birlikleri boyi'nsha jayi'p jazi'li'wi' woni' sanlar nuri'nda ko'rsetiliwin an'satlasti'radi'.

5- mi'sal. Sanlar nuri'nda 1,36 sani'n belgileyik.

Buni'n' ushi'n bul sandi' xana birlikleri boyi'nsha jayami'z: $1,36 = 1 + 0,3 + 0,06$.

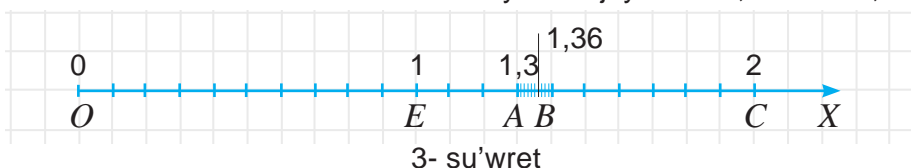

Sanlar nuri' basi'nan OE birlik kesindisin aji'ratami'z ha'm $E(1)$ noqati'n belgileyimiz (3- su'wret). EC birlik kesindini ten'dey 10 bo'lekke bo'lip, birlik kesindinin' wonnan bir u'leslerin payda yetemiz. Wolardan 3 yewin sanap, $A(1,3)$ sani'n belgileyimiz.

Son' 1,3 sani'nan keyin keliwshi birlik kesindinin' wonnan bir u'lesin ja'ne ten'dey 10 bo'lekke bo'lemiz. Na'tiyjede, birlik kesindinin' ju'zden bir u'leslerin payda yetemiz. Wolardan 6 i'n sanap $B(1,36)$ sani'n belgileyimiz.

Wonli'q bo'lsheklerdi xana birlikleri boyi'nsha da sali'sti'ri'w mu'mkin.



6- mi'sal. 4,32 ha'm 6,1 wonli'q bo'lsheklerdi sali'sti'rayi'q.

4,32 sani'ni'n' pu'tin bo'legi 6,1 sani'ni'n' pu'tin bo'leginen kishi ($4 < 6$).

Demak, $4,32 < 6,1$.

7- mi'sal. 3,491 ha'm 3,46 wonli'q bo'lsheklerdi sali'sti'rayi'q.

Bul sanlardin' pu'tin bo'legi – 3, wonnan birlik xanasi'nda turg'an cifrlar bolsa 4 ke ten' boli'p, wolar wo'z ara ten'. Biraq, birinshi bo'lshektin' ju'zden birlik xanasi'nda turg'an 9 cifri', yekinshi bo'lshektin' ju'zden birlik xanasi'nda turg'an 6 cifri'nan u'lken ($9 > 6$). Soni'n' ushi'n, $3,491 > 3,46$.

Wonli'q bo'lshekler ushi'n qosi'w ni'zamlari'

Natural sanlarda bolg'ani' si'yaqli' wonli'q bo'lshekler ushi'nda qosi'wdi'n' wori'n almasti'ri'w ha'm guri'ppalaw ni'zamlari' wori'nli' boladi'.

Onli'q bo'lshekler ushi'n qosi'wdi'n' wori'n almasti'ri'w ni'zami': $a + b = b + a$.

Onli'q bo'lshekler ushi'n qosi'wdi'n' gruppalaw ni'zami': $(a + b) + c = a + (b + c)$.

Bul ni'zamlardi' wo'z betinshe da'lillen' ha'm mi'sallarda tu'sindirip berin'.

Geyde qosi'w ni'zamlari'nan paydalani'w yesaplawlardi' an'satlasti'ri'wi mu'mkin.

8 – mi'sal. Yesaplan': $4,23 + 2,57 + 5,77$.

Wonli'q bo'lshekler ushi'n qosi'wdi'n' wori'n almasti'ri'w ni'zami'nan paydalani'p aqi'rg'i' yeki qosi'li'wshi'lardi'n' worni'n almasti'ri'p alami'z:

$$4,23 + 2,57 + 5,77 = 4,23 + 5,77 + 2,57.$$

Wonli'q bo'lshekler ushi'n gruppapaw ni'zami'nan paydalani'p qosi'li'wshi'lardi' to'mdegishe gruppapaw alami'z ha'm a'mellerdi wori'nlaymi'z:

$$4,23 + 5,77 + 2,57 = (4,23 + 5,77) + 2,57 = 10 + 2,57 = 12,57.$$



Sorawlarg'a juwap berin'

1. Wonli'q bo'lshekler qalay qosi'ladi'?
2. Wonli'q bo'lshekler qalay ali'nadi'?
3. Wonli'q bo'lsheklerdi "bag'ana" ko'riniside qosi'w ni'zami'n tu'sindirin'.
4. Sanni'n' xana birlikleri boyi'nsha jayi'lmasi' dep nege ayti'ladi'?
5. Bo'lshektin' wonli'q jazi'li'wi'nda u'tirden kiyingi: a) birinshi xana; b) yekinshi xana; d) u'shinshi xana; e) to'rtinshi xana qalay ataladi'?
6. Wonli'q bo'lshekler xana birlikleri boyi'nsha qalay sali'sti'ri'ladi'?
7. Sanlar nuri'nda wonli'q bo'lshek birlikleri qalay su'wretlenedi'?



Klasta wori'nlanatug'i'n shi'ni'g'i'wlar

819. Skladqa birinshi ku'ni 2,14 t, yekinshi ku'ni bolsa, 3,65 t ju'k tu'sirildi. Bul yeki ku'n ishinde skladqa qansha ju'k tu'sirilgen?

820. Qosi'ndi'ni' tabi'n':

- a) $3,8 + 6,1$; b) $0,02 + 0,01$; d) $1,23 + 9,77$;
e) $0,003 + 0,006$; f) $1,02 + 0,99$; g) $24,2 + 0,8$.

821. Qosi'ndi'ni' tabi'n':

- a) $8,23 + 2,18$; d) $82,12 + 54,42$; f) $10,32 + 10,01$; h) $6,79 + 2,99$;
b) $11, 35 + 6,47$; e) $4,22 + 10,82$; g) $0,321 + 0,346$; i) $94,514 + 26,465$.

822. Qosi'ndi'ni' tabi'n':

- a) $6,83 + 5,1$; d) $82,1 + 5,42$; f) $10, 52 + 10$; h) $67,9 + 2,99$;
b) $1, 3 + 6,47$; e) $4,20 + 0,8$; g) $1,3 + 0,346$ i) $4,259 + 22,64$.

823. Ayi'rmani' tabi'n':

- a) $9,5 - 6,1$; b) $12,23 - 9,12$; d) $8,9 - 3,6$; e) $24,7 - 0,3$;
f) $0,06 - 0,02$; g) $0,008 - 0,001$; h) $1,01 - 0,99$; i) $42,53 - 2,53$.

824. "Kaptiva" avtomobili "Orlando" avtomobilinen a) qanshag'a uzi'n? b) qanshag'a biyik?



825. Kestede berilgen ayi'rmani' tabi'n'.

Ha'r bir ayi'rmani' to'mendegi kestden tawi'p, woni' to'mendegi bos ketekshege mi'saldi'n' sa'ykes ha'ribin jazi'p shi'g'i'n'. (Ma'selen, 1-mi'sal (0,383- 0,158) di'n' juwabi'-0,225. Bul mi'sal ha'ribi "R" ni' to'mendegi kestdede 0,225 sani'ni'n' asti'na jazami'z).

Yeger barli'q jumi'slardi' duri's wori'nlasan'i'z, 2010-ji'li' O'zbekstan astranomlari' ta'repinen ashi'lg'an kishi planetani'n' ati'n bilip alasi'z.

R	0,383 – 0,158	Q	24,20 – 10,28	A	4,259 – 2,264
M	11, 4 – 6,7	S	0,343 – 0,051	N	6,36 – 4,34
A	8,16 – 5,82	A	67,9 – 2,9	D	5,36 – 1,39

0,292	2,34	4,7	65	0,225	13,92	1,995	2,02	3,97
				R				



826. Kesteni' tolti'ri'n':

<i>a</i>	2,1	2,2	2,3		2,6	2,7	2,9
<i>b</i>	0,4	1,5		1,7			2,8
<i>a + b</i>			4,6	4		3,2	
<i>a – b</i>					0,6		

827. A'mellerdi wori'nlan':

- a) 23,2–16,9; || e) 35,7–0,022; || h) 130,03–0,0023; || l) 2419–33,7024;
 b) 2,34+298; || f) 1,38+0,00384; || i) 0,10005+0,01022; || m) 3 – 2,7561;
 d) 76,2+112,6; || g) 0,0031–0,0017; || k) 102–100,998; || n) 1500–108,0053.

- 828.** a) Qaysi' sannan 4,67 ali'nsa, 3,23 payda boladi'?
 b) Qaysi' sang'a 2,89 qosi'lsa, 8,93 payda boladi'?
 d) 8,34 payda boli'wi' ushi'n qaysi' sandi' 3,56 g'a kemeytiw kerek?
 e) 11,08 payda boli'wi' ushi'n qaysi' sandi' 8,06 g'a arti'ri'w kerek?

829. A'mellerdi wori'nlan':

- a) 2,6 + 3,8 + 3,7 + 0,5; || b) 6,5 – 2,3 + 3,1 – 2,5;
 d) 18 – (1,5 + 0,04) – 6,56; || e) (3,09 + 4,08) – (23 – 20,7).

830. Bul qaysi' sannin' xana birlikleri boyi'nsha jayi'lmasi'?

- a) 0,4 + 0,06 + 0,009; || b) 0,1 + 0,006 + 0,0003; || d) 8 + 0,5 + 0,01 + 0,005;
 e) 4 + 0,1 + 0,02 + 0,0004; || f) 20 + 2 + 0,3 + 0,007; || g) 50 + 6 + 0,06 + 0,007.

831. Wonli'q bo'lshekti xana birlikleri boyi'nsha jayi'n': a) 8,64; b) 7,532; d) 6,2703.

U'lgi: 61,795 = 60 + 1 + 0,7 + 0,09 + 0,005.

832. Birinshi ati'zdan 95,37 t biyday ji'ynap ali'ndi'. Yekinshisinen bolsa birinshi ati'zg'a qarag'anda 16,8 t ko'p biyday ji'ynap ali'ndi'. Yeki ati'zdan ha'mmesi boli'p qansha biyday ji'ynap ali'ng'an?

833. Teploxod ko'lda 27 km/saat tezlik penen 3 saat, keyin bul ko'lge quyi'latug'i'n da'rya ag'i'mi'na qarsi' 4 saat ju'zdi'. Yeger da'rya ag'i'mi'ni'n' tezligi 3 km/saat bolsa teploxod usi' 7 saatta basi'p wo'tken arali'qti' tabi'n'.



U'yde wori'nlantug'i'n shi'ni'g'i'wlar

834. A'mellerdi wori'nlan' ha'm na'tiyjeni tekserin'.

a) $\begin{array}{r} 17,82 \\ + 24,53 \\ \hline \end{array}$	b) $\begin{array}{r} 123,87 \\ + 68,5 \\ \hline \end{array}$	d) $\begin{array}{r} 54,56 \\ - 27,37 \\ \hline \end{array}$	e) $\begin{array}{r} 27,3 \\ - 9,52 \\ \hline \end{array}$
--	--	--	--

835. A'mellerdi wori'nlan':

- a) $1,23 + 46,56$; b) $0,59 - 0,27$; d) $0,43 + 2,98$; e) $4,348 + 1,593$;
 f) $6,05 - 2,87$; g) $7,45 - 4,45$; h) $14,2 + 5,384$; i) $206,48 - 90,507$.
836. Katerdin' ag'i'm boyi'nsha tezligi 23,7 km/saat. yeger ag'i'mni'n' tezligi 3,8 km/saat bolsa, katerdin' ti'ni'q suwdag'i' tezligin ha'm ag'i'mg'a qarsi' tezligin tabi'n'.
837. "Spark" avtomobili "Matiz" avtomobilinen a) qanshag'a uzi'n? b) qanshag'a biyik?

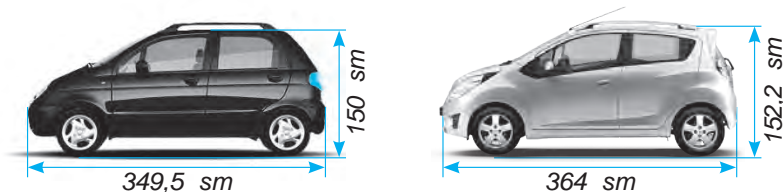

838. A'mellerdi wori'nlan:

- a) $83\ 491 - (124\ 821 : 207 + 2086) + 12\ 763$;
 b) $146\ 325 - (72\ 306 - 1693) + 75\ 014$.
839. 9,35 m uzi'nli'qtag'i' truba yeki bo'lekke bo'lindi. Birinshi bo'lektin' uzi'nli'g'i' 2,89 m. Yekinshi bo'lek birinshi bo'lekten neshe metr uzi'n?
840. A'mellerdi wori'nlan':
- a) $73,12 - (5,34 + 13,12)$; b) $101,3 + (84,7 + 34,23)$;
 d) $(47,28 - 34,98) + (55,02 + 34,98)$; e) $(46,83 + 15,77) - 16,83$.
841. Sanni'n' xana birlikleri boyi'nsha jayi'lmasi'n jazi'n':
- a) 8,36; b) 1,268; d) 0,2304; e) 10,0105.



Qi'zi'g'li' matematikag'a tiyisli ma'seleler

- a) To'mendegi sanlar qosi'ndi'si'n tabi'n': $0,01 + 0,02 + 0,03 + \dots + 0,98 + 0,99$.
 b) To'mendegi sanlar izbe-izliginde ni'zamdi' saqlag'an halda woni'n' keyingi 3 ag'zasi'n jazi'n': 0,3; 0,4; 0,6; 0,9; 1,3; ...

38-§

SANNI'N' JUWI'Q MA'NISI. SANLARDI' DO'N'GELEKLEW

1-su'wrette sa'wlelengen AB kesindinin' uzi'nli'gi' 3 sm, CD kesindinin' uzi'nli'gi' 3,1 sm ge ha'm EF kesindinin' uzi'nli'gi' bolsa 2,8 sm ge ten'. Bul kesindilerden tek AB kesindi uzi'nli'gi' pu'tin sanda an'latil'gan.

Sonday bolsa da, CD kesindinin' uzi'nli'gi' haqqi'nda "ko'bi menen 3 sm ge ten'", EF kesindinin' uzi'nli'gi' haqqi'nda bolsa "kemi menen 3 sm ge ten'" dep te ayti'w mu'mkin. Bul kesindiler uzi'nli'gi'ni'n' juwi'q ma'nisleri.

2-su'wrettegi MN kesindinin' uzi'nli'gi' 3 sm ha'm 4 sm arali'g'i'nda yekenligin ko'riw mu'mkin. Demek, 3 sm – MN kesindinin' uzi'nli'gi' kemi menen, 4 sm – bolsa ko'bi menen ali'ng'an ha'm pu'tin santimetrlerde an'latil'gan juwi'q ma'nisinen ibarat boladi'.

Yeger $a < x < b$ bolsa, a soni – x ti'n' *kemi menen ali'ng'an juwi'q ma'nisi*, b soni – x ti'n' ko'b *menen ali'ng'an juwi'q ma'nisi* dep ataladi'.

MN kesindi uzi'nli'gi' 3,8 sm ge ten' boli'p, wol 3 sm ge qarag'anda 4 ke jaqi'n (sebebi 3,8 den 4 ke bol'gan arali'q: $4 - 3,8 = 0,2$ ga, 3,8 dan 3 shekem bol'gan arali'q esa: $3,8 - 3 = 0,8$ ge ten' boli'p, $0,2 < 0,8$). Demek, MN kesindi uzi'nli'gi'n' shamalap 4 sm ke ten' dep ali'w mu'mkin.

Bul jag'dayda MN kesindinin' uzi'nli'gi' pu'tinge shekem (birlik xanasi'na shekem) do'n'geleklenedi dep ataladi' ha'm bul $MN \approx 4$ smtu'rinde jazi'ladi'. Bul jerde " \approx " belgi – "shama menen" dep woqi'ladi'.

Sandi' wog'an yen' jaqi'n bol'gan pu'tin sang'a almasti'r'i'w - *sandi' pu'tinge shekem do'n'geleklew* dep ataladi'.

3-su'wrette bir neshe sanlardi' pu'tinge shekem do'n'geleklew ko'rsetilgen.

- a) $3,05 \approx 3$; $3,16 \approx 3$; $3,34 \approx 3$ (sebebi, bul sanlar 4 ke qarag'anda 3 ke jaqi'ni'raq),
- b) $3,68 \approx 4$; $3,81 \approx 4$; $3,92 \approx 4$ (sebebi, bul sanlar 3 ke qarag'anda 4 ke jaqi'ni'raq),
- c) $3,5 \approx 4$ (3,5 sani' 3 ha'm 4 sanlari'nan bir qi'yli' uzaqli'qta ha'm bul halda 3,5 sani'n u'lken pu'tin sang'a shekem yag'ni'y 4 ke shekem do'n'geleklewge kelisilgen).

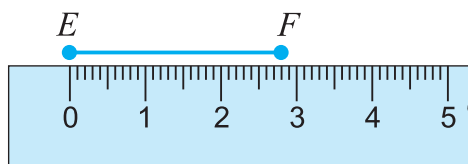
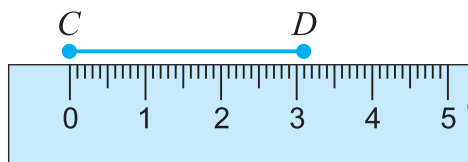
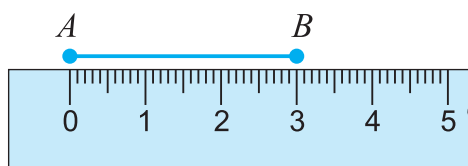

1- su'wret

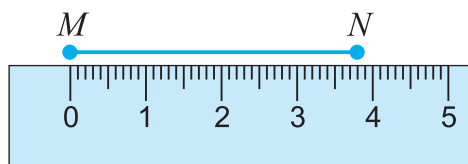

2- su'wret

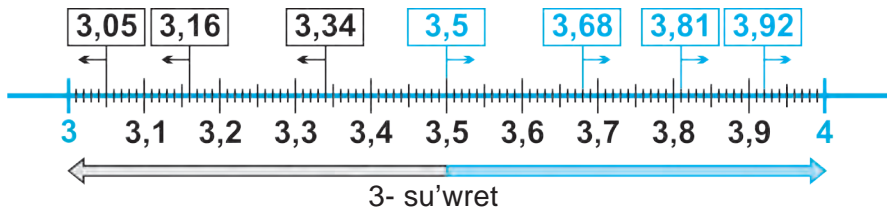

Sanlardi' tek pu'tinge shekem yemes al wonnan birler xanasi'na, ju'zden birler xanasi'na, min'nan birler xanasi'na shekem ha'm tag'i' basqa qa'legen xanag'a shekem do'n'geleklew mu'mkin.

Ma'selen,

$0,23 \approx 0,2$ (wonnan birler xanasi'na shekem do'n'geleklew), sebebi 0,23 sani' 0,3 ke qarag'anda 0,2 ge jaqi'ni'raq.

$2,337 \approx 2,34$ (ju'zden birler xanasi'na shekem do'n'geleklew), sebebi 2,337 sani' 2,33 ke qara'anda 2,34 ke jaqi'ni'raq.

$8,562384 \approx 8,562$ (mi'n'nan birler xanasi'na shekem do'n'geleklew), sebebi 8,562384 sani' 8,563 ke qara'anda 8,562 ge jaqi'ni'raq.

$238 \approx 240$ (wonlar xanasi'na shekem do'n'geleklew), sebebi 238 sani' 230 g'a qara'anda 240 qa jaqi'ni'raq.

$45\ 849 \approx 45\ 800$ (ju'zden birler xanasi'na shekem do'n'geleklew), sebebi 45 849 sani' 45 900 ge qarag'anda 45 800 ge jaqi'ni'raq.

$1\ 120\ 738 \approx 1\ 121\ 000$ (mi'n'lar xanasi'na shekem do'n'geleklew), sebebi, 1 120 738 sani' 1 120 000 ge qarag'anda 1 121 000 ge jaqi'ni'raq.

Uli'wma jag'dayda to'mendegi qag'iyda wori'ni' boladi':



Sandi' qa'legen xanag'a shekem do'n'geleklew ushi'n usi' xanadan keyin kelgen barli'q xana cifrlari' 0 menen almasti'ri'ladi'. Bunda,

- yeger bul cifrlar u'tirden keyin turg'an bolsa, wolar tu'sirilip qaldi'ri'ladi';
- yeger birinshi tu'sirilip qaldi'ri'lg'an yamasa 0 menen almasti'ri'lg'an cifr:

a) 5, 6, 7, 8 yamasa 9 bolsa, wonnan aldin kelgen cifrg'a 1 qosi'ladi';

b) 0, 1, 2, 3 yamasa 4 bolsa, wonnan aldin kelgen cifr sol ta'rizde qaldi'ri'ladi'.

2- mi'sal. 33,4623 sani'n wonnan birler xanasi'na shekem do'n'geleklen'.

Sheshiliwi. Wonnan birler xanasi'nan keyin kelgen 6, 2 ha'm 3 cifrlari'n tu'sirilip qaldi'rami'z. Sebebi, wolar u'tirden keyin turi'pti'. 33,4 ti payda yetemiz. Shep ta'repten birinshi boli'p tu'sirilip qaldi'ri'lg'an cifr 6 bolg'ani' ushi'n wonnan adi'n kelgen cifrg'a 1 di qosami'z: $4 + 1 = 5$. Na'tiyjede 33,5 sani'n payda yetemiz. Demek,, $33,4\boxed{6}23 \approx 33,5$.

3- mi'sal. 1 206 845 sani'n mi'n'lar xanasi'na shekem do'n'gelekleyik.

Sheshiliwi. Mi'n'li'q xanasi'nan keyin kelgen 8, 4, 5 cifrlari'n 0 menen almasti'rami'z. Sol ta'repten birinshi boli'p 0 menen almasti'ri'lg'an san 8 bolg'ani' ushi'n wonnan aldin cifrg'a 1 di qosami'z: $6+1=7$. Na'tiyjede, 1 207 000 sani'n payda yetemiz. Demek, $1\ 206\boxed{8}45 \approx 1\ 207\ 000$.

4-mi'sal. 2149,56 sani'n wonli'q xanasi'na shekem do'n'geleklen'.

Sheshiliwi. 214 $\boxed{9}$,56 ≈ 2150 (do'n'geleklewdi wo'z betinshe ta'riplen').

Sorawlarg'a juwap berin'!



1. Yeger $a < x < b$ bolsa, a ha'm b sanlari x ti'n' qanday ma'nisleri dep ataladi'?
2. Sandi' pu'tinge shekem do'n'geleklew degende neni tu'sinesiz?
3. Sandi' qa'legen xanag'a shekem do'n'geleklew qag'i'ydasin' mi'salda tu'sindirip berin'.
4. Natural san ha'm wonli'q bo'lsheklerdi do'n'geleklew nesi menen bir-birinen pari'qlanadi'? Nesi menen bir-birine uqsaydi'?

Klasta wori'nlanatug'i'n shi'ni'g'i'wlar



- 842.** To'mendegi juwi'q ten'sizliklerdi woqi'n'. Sanlar qaysi' xanag'a shekem do'n'geleklengenligin ani'qlan':
 a) $5,38 \approx 5,4$; b) $82,761 \approx 82,76$; d) $121,3 \approx 121$; e) $2703,98 \approx 2700$;
 f) $8,3459 \approx 8,346$; g) $6,6601 \approx 6,7$; h) $7,5001 \approx 8$; i) $16,433 \approx 16,43$.
- 843.** To'mendegi wonli'q bo'lshek qanday yeki izbe-iz kelgen natural sanlar arasi'na jaylasqan? Bo'lshek bul sanlardan qaysi'si'na jaqi'n?
 a) 3,24; b) 5,38; d) 82,71; e) 121,3; f) 101,801.
U'lgi: a) $3 < 3,24 < 4$. Bul san 3 ke jaqi'n, sebebi 3 ke shekem bolg'an arali'q: $3,24 - 3 = 0,24$, 4 ke shekem bolg'an arali'q bolsa: $4 - 3,24 = 0,76$ ha'm $0,24 < 0,76$.
- 844.** Ten'sizliklerdi woqi'n'. Wortada turg'an sanni'n' kemi menen ha'm arti'g'i' menen ali'ng'an juwi'q ma'nislerin ayti'n'. Wortada turg'an san yeki shette turg'an sanlardi'n' qaysi' birine jaqi'n?
 a) $3 < 3,46 < 4$; b) $13 < 13,9 < 14$; d) $3,2 < 3,26 < 3,3$; e) $2,23 < 2,232 < 2,24$.
- 845.** Yesaplan' ha'm na'tiyjeni birlik xanag'a shekem do'n'geleklen':
 a) $5,3 + 2,4$; b) $2,7 + 8,7$; d) $12,3 - 1,9$; e) $16,5 - 1,8$;
 f) $8,3 + 5,9$; g) $8,3 + 4,6$; h) $6,6 - 6,01$; i) $7,5 - 2,09$.
- 846.** Wonli'q bo'lsheklerdi do'n'geleklen'.
 a) wonnan birler xanasi'na shekem: 0,364; 1,23; 0,919; 4,0785;
 b) ju'zden birler xanasi'na shekem: 0,7348; 1,19105; 2,67903; 11,87412;
 d) mingdan birler xanasi'na shekem: 2,9013; 0,07454; 3,2478; 0,9093;
 e) ju'zlik xanasi'na shekem: 3242; 176082; 82352,14; 10032,983.
- 847.** Pildin' massasi' 5879 kg. Pildin' massasi' shama menen neshe tonna? 
-
- 848.** Jer shari'ni'n' yen' biyik shi'n'i' Djomalunga (Everest) shi'n'i' boli'p, woni'n' biyikligi 8848 m. Bul biyikligi kilometrge shekem do'n'geleklen'.
- 849.** Du'nyani'n' yen' teren' jeri Ti'ni'sh wokeani'ndag'i' Marian shuqi'rli'gi' boli'p yesaplanadi'. Woni'n' teren'ligi – 11 022 m. Woni' km ge shekem do'n' geleklen'.
- 850.** Du'nya xalqi' 2014- ji'lg'a kelip 7 137 577 750 adamg'a jetti. Du'nya xalqi'ni'n' sani'n a) mi'n'g'a shekem; b) milliong'a shekem; d) milliardqa shekem do'n'geleklen'.

- 851.** Do'n'geleklew duri's wori'nlang'an ba?
 a) $4,88 \approx 4,8$; || d) $8,761 \approx 8,77$; || f) $21,3 \approx 22$;
 b) $12,34 \approx 12,34$; || e) $3,6601 \approx 6,70$; || g) $3,5001 \approx 3$.
- 852.** Bo'lsheklerdi pu'tinge shekem (birlik xanasi'na shekem) do'n'geleklen':
 a) 7,265; || b) 11,638; || d) 0,23; || e) 8,5; || f) 300,499; || g) 6,5108.
U'lg'i: $45,834 \approx 46$ (Sebebi, birlik xanasi'nan keyingi tu'sirip qaldi'ri'lg'an san 8. Soni'n' ushi'n birlik sani' 5 ke 1 di qosami'z).
- 853.** Bir pud 16,38 kg g'a ten'. Yeger wol pu'tin kiliogrammg'a shekem do'n'geleklense, neshe kilogramm boladi'? Wonnan birge shekem do'n'geleklense-she?
- 854.** Bo'lsheklerdi do'n'geleklen':
 a) wannan birlik xanasi'na shekem: 2,781; 3,1423; 203,962; 62,35;
 b) ju'zden birlik xanasi'na shekem: 0,07268; 1,35506; 10,081; 76,544;
 d) wonli'q xanasi'na shekem: 167,1; 2085,04; 444,4; 300,7.
- 855.** Do'n'geleklew duri's wori'nlang'an boli'wi' ushi'n ketekshe worni'na qanday cifrlardi' qoyi'w mu'mkin:
 a) $2,38 \square \approx 2,3$; || b) $1,3 \square \approx 1,4$; || d) $2,03 \square \approx 2,04$;
 e) $0, \square \approx 0$; || f) $5,60 \square \approx 5,60$; || g) $12,08 \square \approx 12,09$.



U'yde wori'nlanatug'i'n ma'seleler

- 856.** Ten'sizliklerdi woqi'n'. Wortada turg'an sanni'n' kemi menen ha'm arti'gi' menen ali'ng'an juwi'q ma'nislerin ayti'n'. Wortada turg'an san yeki shette turg'an sanlardi'n' qaysi' birine jaqi'n?
 a) $5 < 5,32 < 6$; || b) $12,4 < 12,42 < 12,5$; || d) $1,37 < 1,378 < 1,38$.
- 857.** Bo'lsheklerdi do'n'geleklen':
 a) wannan birler xanasi'na shekem: 42,281; 0,193; 3,932; 2,38;
 b) ju'zdn birler xanasi'na shekem: 0,0708; 31,3590; 0,0891; 6,597;
 d) wonli'q xanasi'na shekem: 476,1; 1039,02; 856,2; 1000,2.
- 858.** Bo'lsheklerdi do'n'geleklen':
 a) birlik xanasi'na shekem: 1,69; 1,198; 37,444; 802,3032;
 b) wannan birler xanasi'na shekem: 0,3691; 0,8218; 0,9702; 61,3501.
- 859.** Tashkentten Buxarag'a shekem bolg'an arali'q 600 km. Bir waqi'tti'n' wo'zinde Tashkentten 90 km/saat tezlik penen ju'retug'i'n avtomobil, Buxaradan bolsa tezligi 110 km/saat bolg'an yekinshi avtomobil yolg'a shi'qti'. Wolar jolda neshe saattan keyin ushi'asadi'?



Toshkent

?



Buxoro



- 860.** To'mendegi sanlar qaysi' xanag'a shekem do'n'geleklengen? Wolar duri's do'n'geleklengen be?
- a) $54,38 \approx 54,3$; b) $23, 61 \approx 23,7$; d) $71,3 \approx 72$;
 e) $2,42 \approx 2,4$; f) $0,6601 \approx 0,70$; g) $63,901 \approx 64$.
- 861.** A'mellerdi wori'nlan': $((37,3 + 21,7) \cdot 13 + 8688) : 31 - 196$.
- 862.** Jer shari' ekvatoridi'n' uzi'nli'g'i' 40 075 696 m. Bul uzi'nli'qti' kilometrge shekem don'geleklen'.
- 863.** Du'nyada xalqi' yen' ko'p ma'mleket Qi'tay boli'p yesaplanadi'. Bul ma'mlekette 1 370 811 348 adam jasadidi'. Qi'tay xalqi' sani'n: a) minglar; b) millionlar; d) milliardlar xonasigacha yaxlitlang.

Matematika tariyxi'na tiyisli sorawlar



1. Ten'izde arali'q ten'iz milinde wo'lshenedi. 1 ten'iz mili 1,853 km ge ten'. Bul sandi' a) wannan 1 ge shekem; b) 1 ge shekem do'n'geleklen'. 1 ten'iz mili shama menen neshe km ge ten'?
2. A'yyemde yelimizde arali'q shaqi'ri'mlarda wo'lshengen. 1 shaqi'ri'm shama menen 1,0688 km ge ten' bolg'an. Bul sandi' a) ju'zden birge shekem; b) wannan birge shekem; d) birler xanasi'na shekem do'n'geleklen'. 1 shaqi'ri'm shama menen neshe km ge ten'?
3. A'yyemde da'rixanalarda da'riler arnawli' da'rixana unsiyasi'nda wo'lshengen. 1 da'rixana unsiyasi' 31,1035 grammg'a ten' bolg'an. Bul sandi': a) ju'zden birge shekem; b) wannan birge shekem; d) birler xanasi'na shekem do'n'geleklen'. 1 da'rixana unsiyasi' shama menen neshe grammg'a ten'?
4. Angliyada massa wo'lshem birligi si'pati'nda funt ta isletiledi. 1 ingliz funti 0,45359237 kg g'a ten'. Bul sadi' a) mi'n'nan birge shekem; b) ju'zden birge shekem; d) wannan birge shekem; e) birler xanasi'na shekem do'n'geleklen'. 1 funt shama menen neshe grammg'a ten'?

Qi'zi'g'li' matematikag'a tiyisli ma'seleler



- 1) $4 * 5$ jazi'wi'ndag'i' juldizsha warni'na neshe qoyi'lsa, 4 ten u'lken, biraq 5 ten kishi san payda boladi'?
- 2) $1001 \cdot 1002 \cdot 1003 \cdot 1004 \cdot 1005 \cdot 1006 \cdot 1007 \cdot 1008 \cdot 1009$ ko'beyme qanday san menen tamamlanadi'?

- 864.** U'sh qapta 1,97 c un bar. Birinshi ha'm yekinshi qaptag'i' un massasi' ten'. U'shinshi qapta bolsa birinshi qapqa qarag'anda 0,11 c ko'p un bar. Ha'r qaysi' qapta qanshadan un bar?
- 865.** Tuvri'mu'yeshliktin' yeni 14 sm boli'p, wol uzi'nli'g'i'ni'n $\frac{2}{5}$ bo'legin quraydi'. Tuvri'mu'yeshliktin' maydani'n tabi'n'.
- 866.** Stansiyadan 50 km/saat tezlik penen ju'k poezdi jolg'a shi'qti'. 3 saat wo'tkennen keyin usi' stansiyadan woni'n' izinen 80 km/saat tezlik penen Elektropoezd jolg'a shi'qti'. Elektropoezd jolg'a shi'qqannan keyin neshe saattan son' ju'k poezdi quwi'p jetedi?
- 867.** Arasi'ndag'i' arali'q 782 km bolg'an yeki qaladan yeki poezd bir-birine qarap tu'rli waqit'ta jolg'a shi'qti'. Birinshi poezd 52 km/saat, yekinshisi 61 km/saat tezlik penen ju'rdu. Birinshi poezd 416 km ju'rgennen keyin yekinshisi menen ushi'rasti'. Poezdlardan biri yekinshisinen neshe saat aldi'n jolg'a shi'qqan?
- 868.** Bir adam bazarg'a ma'yek ali'p kelip, birinshi qari'ydarg'a ma'yeklerdin' yari'mi'n ha'm ja'ne bir, yekinshi qari'ydarg'a qalg'an ma'yeklerdin' yari'mi'n ha'm ja'ne bir ma'yek satti'. Sonnan son' 14 ma'yek qaldi'. Sati'wshi' bazarg'a barli'g'i' boli'p neshe dana ma'yek ali'p kelgen?
- 869.** U'shmu'yeshliktin' bir ta'repi 83,6 sm, yekinshi ta'repi birinshisinen 14,8 sm, u'shinshisi yekinshisinen bolsa 8,6 sm arti'q. U'shmu'yeshliktin' perimetrin tabi'n'.
- 870.** Da'ryani'n' teren'ligi 5,78 m. Ko'pir quri'w ushi'n isletiletug'i'n bag'ana da'rya tu'bindegi jerge 2,1 m qag'i'lg'an boli'p, wol suw betinen 5,41 m shi'g'i'p turadi'. Bag'anani'n' uzi'nli'g'i' qansha?
- 871.** Yeki ati'zdan kartoshka wo'nimi ji'ynap ali'ndi'. Birinshi ati'zdan 195,7 t, yekinshisinen bolsa birinshi ati'zg'a qarag'anda 72,8 t ko'p kartoshka ji'ynaldi'. Yeki ati'zdan neshe tonna kartoshka ji'ynap ali'ng'an?
- 872.** Bir woram gezlemeden birinshi ku'ni 13,72 m, yekinshi ku'ni 24,3 m, u'shinshi ku'ni bolsa 18,28 m sati'ldi'. Sonda 3,7 m gezleme sati'lmay qaldi'. Woramda neshe metr gezleme bolg'an?
- 873.** Jol quri'wshi'lardi'n' bir topari' joldi' A awi'ldan, yekinshi topari' B awi'ldan birbirine qarap quri'p kelmekte. Birinshi topar 7,5 km, yekinshisi bolsa wonnan 1,3 km arti'q jol qurg'annan son' ja'ne 1,8 km jol quri'lmay qaldi'. A ha'm B awi'llar arasi'ndag'i' arali'qti' tabi'n'.
- 874.** Si'rda'rya walayati'ni'n' maydani' 5,1 mi'n'. km². Bul Nawayi' walayati'ni'n' maydani'nan 105,7 km², Qaraqalpaqstan Respublikasi'ni'n' maydani'nan bolsa 159,8 mi'n' km² qa kem. Nawayi' walayati' ha'm Qaraqalpaqstan Respublikasi' maydani' neshe mi'n' kvadrat kilometrdir quraydi'?

875. To'wendegi su'wretler boyi'nsha ha'ra'ketke tiyisli ma'seleler du'zin' ha'm wolardi' sheshin'.

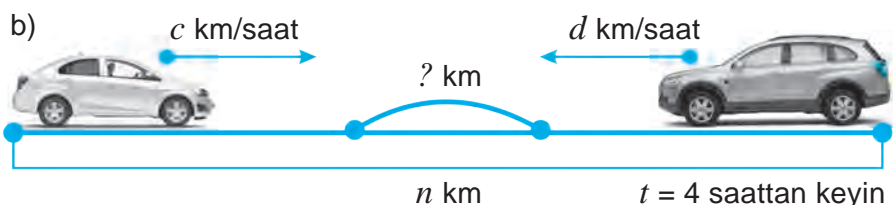
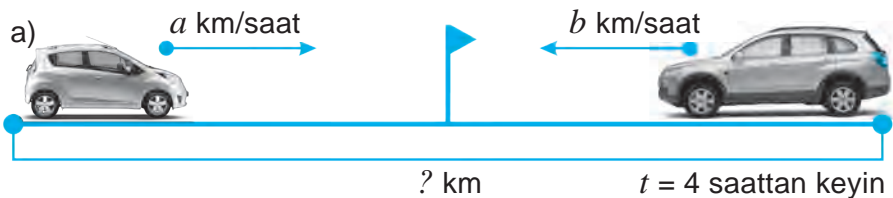

876. Vilosipedshinin' tezlighi 15 km/saat, piyadani'n' tezlighi wonnan 9,7 km/saat kem. Yeger wolar bir-birine qarap kiyati'rg'an bolsa, wolar bir-birine qanday tezlik penen jaqi'nlaspaqta?
877. Teploxodti'n' wo'z (ti'ni'sh suwdagi'i) tezlighi 21,6 km/saat. Ag'i'mni'n' tezlighi 4,9 km/saat. Teploxodti'n' ag'i'm boyi'nsha ha'm ag'i'mg'a qarsi' tezlighin tabi'n.
878. 6-klass woqi'wshi'lari' 609,8 kg, 7-klass woqi'wshi'lari' bolsa wolardan 75,5 kg ko'p alma terdi. Ha'r yeki klass woqi'wshi'lari' neshe kg alma tergen?
879. Farxad 34,8 kg, Bahram wonnan 4,7 kg ko'p, Dilshad bolsa Bahramg'a qarag'anda 5,2 kg ko'p ju'zim tergen. Balalar ja'mi neshe kg ju'zim tergen?
880. Bir sayaxatshi' yeki qala arasi'ndagi'i arali'qti' 10 saatta, yekinshisi bolsa 15 saatta basi'p wo'tedi. Yeger wolar usi' qalalardan bir-birine qarap bir waqit'ta jolg'a shi'qsa, neshe saattan keyin wolar ushi'rasadi'?
881. Suw asti' kemesi suw asti'nda suw u'stine sali'sti'rg'anda 17 ma'rte arti'q arali'qti' wo'tti. yeger wol suw u'stinde suw asti'na qarag'anda 320 km kem jol basi'p wo'tken bolsa, suw asti'nda qansha jol basi'p wo'tken?
882. Ekskovator 4 saatta 280 m³ topi'raq qazi'p shi'g'aradi'. Yeger ekskovator kovshi'ni'n' ko'lemi 2 m³ bolsa, wol ha'r saatta neshe kovsh topi'raq qazi'p shi'g'arg'an?
883. U'shmu'yeshliktin' bir ta'repi 8,65 dm boli'p, wol yekinshi ta'repinen 1,7 dm uzi'n. yeger u'shmu'yeshliktin' perimetri 23,89 dm bolsa, woni'n' u'shinshi ta'repinin' uzi'nli'g'i'n tabi'n'.
884. To'rt sanni'n' qosi'ndi'si' 16,712 ge ten'. Yekinshi san 3,062 ge ten' ha'm wol birinshi sannan 1,922 ge, u'shinshi sannan bolsa, 0,18 ge arti'q. To'rtinshi san yekinshi sannan qansha arti'q?
885. Nanbayxanada nan jabi'w ushi'n birinshi ku'ni 5,42 t, yekinshi ku'ni birinshi ku'ng'e qarag'anda 2,43 t, u'shinshi ku'ni bolsa da'slepki yeki ku'ndegige

qarag'anda 3,21 t kem un jumsaldi'. Nanbayxanada usi' u'sh ku'nde qansha un jumsalg'an?

- 886.** Woqi'wshi'g'a matematika pa'ni olimpiadasi'na tayarlani'wi' ushi'n 150 ma'sele berildi. Woqi'wshi'ni'n' sheshken ma'seleleri sheshpegenine qarag'anda 4 ma'rte arti'q bolsa, wol neshe ma'sele sheshken?
- 887.** Ha'wiz 6 saatta suw menen toladi'. 1 saat 25 minutta ha'wizdin' qansha bo'legi suw menen toladi'?
- 888.** a) Jerdin' diametri 12 756 km boli'p, bul Quyashti'n' diametrinen shama menen 109 ma'rte qi'sqa. Quyashti'n' diametrin tabi'n'.
 b) Jerdin' diametri 12 756 km, Aydiki bolsa 3474 km. Jerdin' diametri Ay diametrinen shama menen neshe ma'rte uzi'n?
 d) Jerden Quyashqa shekem bolg'an arali'q 150 000 000 km. Ayg'a deyin bolg'an arali'q bolsa 384 400 km. Ay Quyashqa qarag'anda Jerge shama menen neshe ma'rte jaqi'n?



Bilimin'izdi si'nap ko'rin'!

Bul bap materiallari'n u'yrenip shi'g'i'p, to'mendegi ma'selelerdi sheshe ali'wi'n'i'z sha'r t! Qadag'alaw jumi'si' aldi'nan wo'zin'izdi si'nap ko'rin'!

Test. Duri's juwapti' ani'qlan'.

- Sandi' do'n'geleklewde, sol ta'repten birinshi boli'p tu'sirip qaldi'ri'lg'an cifr bolsa, wannan aldi'n kelgen cifr qalay wo'zgeredi?
 A. 1 ge artadi'; || B. 1 ge kemeyedi; || D. Wo'zgermeydi; || E. 10 g'a artadi'.
- 1123,0956 sani'nin' mi'n'nan birler xanasi'nda qaysi' san turi'pti'?
 A. 1; || B. 6; || D. 5; || E. 0.
- 14,209653 sani'n ju'zden birler xanasi'n shekem do'n'geleklen'.
 A. 14,2096; || B. 14,2097; || D. 14,209; || E. 14,21.

9-qadag'alaw jumi's u'lgisi

- | | | |
|------------------------------|--|-------------------------------|
| a) Sanlardi' sali'sti'ri'n': | | b) Kilometrlerde an'lati 'n': |
| 7,195 ha'm 12,1; | | 2 km 156 m; |
| 8,276 ha'm 8,3; | | 8 km 70 m; |
| 0,76 ha'm 0,7598; | | 685 m; |
- A'mellerdi wori'nlan':
 a) $12,3 + 5,26$; || b) $79,1 - 6,08$; || d) $0,48 + 0,057$; || e) $5 - 1,63$.
- a) 3,18; 30,625; 257,51 ha'm 0,28 sanlardi' birliklerge shekem do'n'geleklen'.
 b) 0,531; 12,467; 8,5452 ha'm 0,009 sanlardi' ju'zden birlerge shekem do'n'geleklen'.
- Qayi'qti'n' wo'z tezligi 3,4 km/saat, ag'i'mg'a qarsi' tezligi bolsa 0,8 km/saat. Qayi'qti'n' ag'i'm boyi'nsha tezligin tabi'n'.
- m ning $0,71 < m < 0,74$ sha'tin qanaatlandi'ri'wshi' 4 ma'nisin jazi'n'.

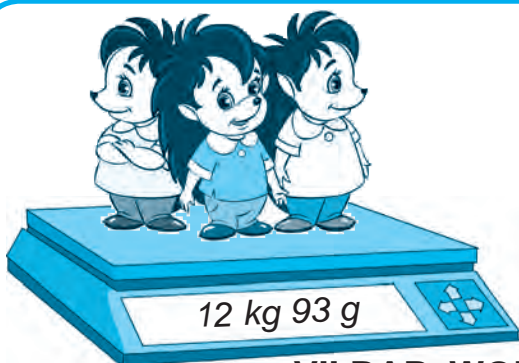

$$12,93 : 3 = 4,31$$

$$4,31 \cdot 3 = 12,93$$

$$12,93 : 4,31 = 3$$

VII BAP. WONLI'Q BO'LSHEKLERDI KO'BEYTIW HA'M BO'LIW

40-§.

WONLI'Q BO'LSHEKLERDI NATURAL SANG'A KO'BEYTIW

Paxta maydani' kvadrat formasi'nda boli'p, woni'n' ta'repi 1,14 km ge ten'. Bul maydanni'n' perimetrin tabayi'q. Bizge belgili, bul maydan perimetri to'rt ta'repinin' uzi'nli'qlari'ni'n' qosi'ndi'si: $1,14 + 1,14 + 1,14 + 1,14 = 4,56$ g'a, yag'ni'y 4,56 km ge ten' boladi'.

Ma'seleni sheshiw ushi'n ha'r biri 1,14 ke ten' bolg'an to'rt qosi'li'wshi'ni'n' qosi'ndi'si'n tapti'q. Bul qosi'ndi' 1,14 sani'ni'n' natural san 4 ke ko'beymesi dep ataladi' ha'm $1,14 \cdot 4$ ko'rinishide jazi'ladi'.

Wonli'q bo'lsheklardin' natural sang'a ko'beymesi dep ha'r biri wonli'q bo'lshekke ten', sani' bolsa berilgen natural sang'a ten' bolg'an qosi'li'wshi'lardi'n' qosi'ndi'si'na ayti'ladi'.

$1,14 \cdot 4$ ko'beyme sanlardi' "bag'ana" usi'li'nda ko'beytip te tabi'w mu'mkin.

Buning uchun vergulga e'tibor bermay, 114 va 4 sonlarini ko'paytiramiz.

$\begin{array}{r} 1,14 \\ \times 4 \\ \hline 4,56 \end{array}$	<p>Berilgen wonli'q bo'lsheklarde u'tirden keyin 2 cifr bar. Soni'n' ushi'n, payda bolg'an 456 ko'beymenin' won' ta'repinen de 2 cifri'n aji'rati'p u'tir qoyami'z.</p>
--	---

Wonli'q bo'lshekni natural sang'a ko'beytiw ushi'n

- woni'n' u'tirine itibar bermey natural sang'a ko'beytiriledi;
- wonli'q bo'lshekke u'tirden keyin neshe cifr bolsa, payda bolg'an ko'beymede de sonday cifr won' ta'repinde u'tir menen aji'raladi'.

1-mi'sal. $2,45 \cdot 12$ ko'beymeni tabayi'q.

$\begin{array}{r} 2,45 \\ \times 12 \\ \hline 490 \\ + 245 \\ \hline 29,40 \end{array}$	<p>Joqari'dagi' qag'i'yda boyi'nsha, aldi'n 245 ti 12 ge ko'beytemiz: $245 \cdot 12 = 2940$.</p> <p>Berilgen wonli'q bo'lshekke u'tirden keyin 2 cifr bar. Ko'beymenin' won' ta'repinen 3 cifrdi u'tir menen aji'ratami'z.</p> <p>Na'tiyjede $2,45 \cdot 12 = 29,40 = 29,4$ ti payda yetemiz.</p>
---	---

$$\begin{array}{r}
 6,245 \\
 \times 10 \\
 \hline
 000 \\
 + 6245 \\
 \hline
 62,450
 \end{array}$$

2-mi'sal. a) ko'beymeni tabayi'q $6,245 \cdot 10$.

Joqari'dag'i' qag'i'ya boyi'nsha, aldi'n 6245 ti 10 g'a ko'beytemiz: $6245 \cdot 10 = 62450$.

Berilgen wonli'q bo'lshekte u'tirden keyin 3 cifr bar.

Ko'beymenin' won' ta'repinen 3 cifrdi u'tir menen aji'ratami'z.

Na'tiyjede $6,245 \cdot 10 = 62,450 = 62,45$ ti payda yetemiz.

Kishi izertlew jumi'si'

a) $6,245 \cdot 10 = ?$ || b) $6,245 \cdot 100 = ?$ || d) $6,245 \cdot 1000 = ?$

tiyindilerdi tabi'n' ha'm na'tiyjeni ten'liktin' won' ta'repine jazi'n'

Payda bolg'an u'sh ten'likti jaqsi'lap ko'zden wo'tkerin' ha'm to'mendegi sorawlarg'a izbe-iz juwap berin':

1) Ha'r bir mi'salda birinshi ko'beytiwshi ha'm ko'beymedegi u'tirler jag'dayi' birbirinen qalay pari'q yetedi?

2) Yekinshi ko'beytiwshilerde neshe nol bar?

3) Birinshi mi'salda u'tir qansha tan'ba qaysi' ta'repke ji'lji'ydi'? yekinshi mi'saldane? U'shinshi mi'salda she?

4) U'tirdin' qansha tan'ba ji'lji'wi' nege baylani'sli' boladi'?

Joqari'dag'i' sorawlarg'a berilgen juwaplarg'a tiykarlani'p, wonli'q bo'lshekti 10, 100, 1000 ha'm tag'i' basqa sanlarg'a ko'beytiw qag'i'ydasini da'lillen'. Bul kishigirim izertlewlerin'iz juwmag'i' boladi'. Yeger barli'q sorawlarg'a duri's juwap berip, duri's juwmaq shi'g'arg'an bolsani'z, to'mendegi qag'i'ydan qaytadan ashqan bolasi'z:



Wonli'q bo'lshek ha'm 10, 100, 1000 ha'm tag'i' basqa (1 ha'm bir neshe nollardan ibarat) sanlardi'n' ko'beymesin tabi'w ushi'n bul sanlarda neshe nol bolsa, wonli'q bo'lshektegi u'tirdi sonshama won'g'a qaray ji'lji'ti'w jetkilikli

Bul qag'i'ya boyi'nsha to'mendegi ko'beymelerdi an'sat tabami'z:

$5,86 \cdot 10 = 58,6$ (wonli'q bo'lshektegi u'tirdi 1 tan'ba won'g'a ji'lji'tti'q),

$0,294 \cdot 100 = 29,4$ (wonli'q bo'lshektegi u'tirdi 2 tan'ba won'g'a ji'lji'tti'q),

$0,013 \cdot 1000 = 13$ (wonli'q bo'lshektegi u'tirdi 3 tan'ba won'g'a ji'lji'tti'q).

U'tirdi ji'li'sti'rg'anda wonli'q bo'lshekte jeterli cifrlar bolmasa, aldi'n wonli'q bo'lshektin' won' ta'repine jeterli noller jazi'ladi' (bilesiz, bul jag'dayda wonli'q bo'lshek wo'zgermeydi), son' u'tir ji'lji'ydi'. Buni' to'mendegi mi'salda ko'riwimiz mu'mkin:

3- mi'sal. $4,95 \cdot 1000$ ko'beymeni yesaplayi'q.

Ko'rip turg'ani'n'izday, $4,95$ tin' u'tirden keyin yeki cifri' bar, biz bolsa u'tirdi won' ta'repke u'sh tan'bag'a ji'lji'tpaqshi'mi'z. Soni'n' ushi'n, aldi'n bo'lshektin' won' ta'repine bir nol qoyi'p, son' u'tirdi u'sh tan'ba won'g'a ji'lji'tami'z:

$4,95 \cdot 1000 = 4,950 \cdot 1000 = 4950$



Sorawlarg'a juwap berin'!

1. Wonli'q bo'lshektin' natural sang'a ko'beymesi dep nege ayti'ladi'?

2. Wonli'q bo'lshekti natural sang'a ko'beytiw ni'zami'n ayti'n' ha'm woni' mi'sallarda tu'sindirip berin'.

3. Wonli'q bo'lshekti 10, 100, 1000 ha'm basqada sanlarg'a ko'beytiw qag'i'ydasini ayti'n' ha'm woni' mi'sallarda tu'sindirip berin'.

Klasta wori'nlanatug'i'n shi'ni'g'i'wlar



889. Qosi'ndi'ni' aldi'n ko'beymege keltirip yesaplan':

a) $2,7 + 2,7 + 2,7 + 2,7 + 2,7$; || b) $0,35 + 0,35 + 0,35 + 0,35 + 0,35 + 0,35$.

890. Yesaplan':

a) $0,7 \cdot 8$; || b) $0,15 \cdot 6$; || d) $3,4 \cdot 4$; || e) $2,5 \cdot 8$;
f) $5,4 \cdot 3$; || g) $0,02 \cdot 12$; || h) $3 \cdot 0,008$; || i) $4 \cdot 0,061$.

891. To'mendegi sanlar ko'beymesinde u'tirden keyin neshe cifr boladi'?

a) $2,42 \cdot 621$; || b) $12,3 \cdot 455$; || d) $12,467 \cdot 602$; || e) $0,007 \cdot 68$;
f) $5,412 \cdot 303$; || g) $52 \cdot 0,903$; || h) $0,034 \cdot 12$; || i) $1,05 \cdot 168$.

892. Ko'beymede tu'sirilib qaldi'ri'lg'an u'tirdi qoyi'n'..

a) $1,43 \cdot 62 = 8866$; || b) $32,4 \cdot 43 = 13932$; || d) $2,64 \cdot 61 = 16104$;
e) $0,033 \cdot 68 = 2244$; || f) $5,012 \cdot 33 = 165396$; || g) $62 \cdot 0,503 = 31146$;
h) $0,074 \cdot 22 = 1628$; || i) $2,03 \cdot 86 = 17458$; || j) $28 \cdot 1,002 = 28056$.

893. Ko'beytiwdi wori'nlan':

a) $0,213 \cdot 26$; || b) $0,12 \cdot 25$; || d) $12,25 \cdot 212$; || e) $1,5 \cdot 830$;
f) $0,41 \cdot 23$; || g) $1,2 \cdot 241$; || h) $2,99 \cdot 102$; || i) $13 \cdot 1,002$;
j) $790 \cdot 0,04$; || k) $52 \cdot 0,003$; || l) $1,7 \cdot 160$; || m) $233 \cdot 0,003$.

894. Yeger $6,4 \cdot 17 = 108,8$ yekenligi belgili bolsa, to'mendegi ko'beymeni tabi'n':

a) $64 \cdot 17$; || b) $6,4 \cdot 170$; || e) $640 \cdot 17$; || f) $64 \cdot 170$;

895. a) 25,1; 0, 56; 120,1; 75,9 sanlari'n 6 ma'рте artti'ri'n';

b) 13,5; 2,35; 83,52; 7,003 sanlari'n 8 ma'рте artti'ri'n'.

896. Poezd 95 km/saat tezlik penen 2,5 saatta neshe kilometr ju'redi? 0,8 saatta ne?

897. Abdullaevlar shan'arag'i'ni'n' wo'tken ji'lg'i' ja'mi da'ra'ma'ti 5 600 000 swmdi' quraydi'. Bi'yi'l bolsa bul ko'rsetkish 1,2 ma'рте asqan. Bul ji'li' Abdullaevlar shan'arag'i'ni'n' da'ra'ma'ti neshe swmdi' quraydi'?



898. Yesaplan':

a) $6,42 \cdot 10$; || $0,17 \cdot 10$; || $3,8 \cdot 10$; || $0,1 \cdot 10$; || $0,01 \cdot 10$;
b) $6,387 \cdot 100$; || $20,35 \cdot 100$; || $0,006 \cdot 100$; || $0,75 \cdot 100$; || $0,1 \cdot 100$;
d) $45,48 \cdot 1000$; || $7,8 \cdot 1000$; || $0,00081 \cdot 1000$; || $0,006 \cdot 1000$; || $0,12 \cdot 10\ 000$.

899. a) 0,4 sani' 0,04; 0,004; 0,0004 sanlari'nan neshe ma'рте u'lken?

b) 348,1 sani' 34,81; 0,3481; 0,0 3481 sanlari'nan neshe ma'рте u'lken?

d) 546 sani' 0,0546; 0,546; 54,6 sanlari'nan neshe ma'рте u'lken?

900. Tu'sirilib qaldi'ri'lg'an noller ha'm u'tirdi qoyi'n':

a) $0,008 \cdot 11 = \dots 88$; || d) $0,2 \cdot 41 = \dots 82$; || f) $0,004 \cdot 15 = \dots 60$.

b) $0,04 \cdot 2 = \dots 8$; || e) $0,05 \cdot 20 = \dots 100$; || g) $0,008 \cdot 25 = \dots 200$.

U'lgi: $0,3 \cdot 1,5 = 0,45$;

901. An'latpani' ko'beyme ko'riniside su'wretlen:

a) $7,6k + 3,4k$; || b) $25,3y + 4,11y$; || d) $8,92x - 5,92x$; || e) $64a - 0,8a$.

U'lgi: $7,6z + 3,4z = (7,6 + 3,4) \cdot z = 11z$

902. a) $x = 8$ ha'm $y = 10$ bolg'anda, $5,2x + 1,73y$ an'latpa ma'nisin tabi'n';
 b) $a = 85$ ha'm $b = 10$ bolg'anda, $16,52a + 18,1b$ an'latpa ma'nisin tabi'n'.
903. Yesaplan':
 a) $84,25 \cdot 3$; b) $0,125 \cdot 312$; d) $(4,8 + 3,5) \cdot 5$; e) $(18,6 - 9,1) \cdot 3$.
904. Ka'nshilerdin' birinshi brigadasi' 2302 t ko'mir qazi'p aldi'. Yekinshi brigada birinshisinen 1,4 ma'rte ko'p, u'shinshi bolsa yekinshisinen 540 t kem ko'mir qazi'p aldi'. U'sh brigada qansha ko'mir qazi'p alg'an?
905. Birinshi ati'zdi'n' maydani' 103,6 gektar, yekinshisinin' maydani' wonnan 32 gektar arti'q. Birinshi ati'zdi'n' ha'r gektari'nan 38 ts, yekinshisinin' ha'r gektari'nan 32 ts biyday ali'ng'an bolsa, yeki ati'zdan qansha biyday wo'nimi ali'ng'an?



U'yde wori'nlanatug'i'n ma'seleler

906. Qosi'ndi'ni' aldi'n ko'beymege keltirin' ha'm keyin yesaplan':
 a) $4,9 + 4,9 + 4,9 + 4,9 + 4,9 + 4,9 + 4,9 + 4,9 + 4,9$;
 b) $1,73 + 1,73 + 1,73 + 1,73 + 1,73 + 1,73 + 1,73 + 1,73 + 1,73$.
907. To'mendegi sanlar ko'beymesinde u'tirden keyin neshe cifr boladi'?
 a) $7,49 \cdot 691$; b) $0,003 \cdot 61$; d) $0,024 \cdot 17$;
 e) $19,463 \cdot 607$; f) $57 \cdot 0,902$; g) $11111 \cdot 1,0007$.
908. To'mendegi sanlar ko'beymesinde tu'sirliq qaldi'ri'lg'an u'tirdi qoyi'n'.
 a) $1,42 \cdot 69 = 9698$; b) $0,022 \cdot 61 = 1342$; d) $0,034 \cdot 99 = 3366$;
 e) $9,64 \cdot 61 = 58804$; f) $69 \cdot 0,502 = 34638$; g) $91 \cdot 1,007 = 91637$.
909. Ko'beytiwdi wori'nlan':
 a) $7,1 \cdot 61$; b) $0,91 \cdot 57$; d) $19,5 \cdot 1$; e) $0,4 \cdot 29$;
 f) $0,14 \cdot 3$; g) $2,9 \cdot 40$; h) $0,6 \cdot 91$; i) $0,22 \cdot 50$.
910. Ko'beytiwdi wori'nlan':
 a) $0,912 \cdot 76$; b) $17,75 \cdot 919$; d) $1,5 \cdot 120$; e) $0,41 \cdot 92$;
 f) $9,99 \cdot 107$; g) $390 \cdot 0,04$; h) $12 \cdot 1,009$; i) $1,3 \cdot 160$.



911. Yesaplan':
 a) $3,22 \cdot 10$; $0,45 \cdot 10$; $6,9 \cdot 10$; $0,3 \cdot 10$; $0,08 \cdot 10$;
 b) $1,257 \cdot 100$; $40,78 \cdot 100$; $0,005 \cdot 100$; $0,23 \cdot 100$; $0,6 \cdot 100$;
 d) $15,32 \cdot 1000$; $5,1 \cdot 1000$; $0,00029 \cdot 1000$; $0,003 \cdot 1000$; $0,72 \cdot 10\ 000$.
912. 1) 153,2 sani a) 15,32, b) 0,1532, d) 0,01532 sanlari'nan neshe ma'rte u'lken?
 2) 21,7 sani' a) 2,17, b) 0,217, d) 0,0217 sanlari'nan neshe ma'rte u'lken?
913. Yeger $8,7 \cdot 13 = 113,1$ yekenligi belgili bolsa, to'mendegi ko'beymeni tabi'n':
 a) $87 \cdot 13$; b) $8,7 \cdot 130$; d) $0,87 \cdot 13$; e) $870 \cdot 13$; f) $87 \cdot 130$; g) $0,087 \cdot 13$.
914. a) 75,1; 0,56; 190,1; 35,7 sanlari'n 7 yese arttir i'n';
 b) 12,5; 7,25; 12,59; 3,002 sanlari'n 12 yese arttir i'n'.
915. Bir qi'yl'i' jo'neliste ha'reketlenip ati'rg'an ju'k poyezdi'ni'n' tezligi 1,2 km/min, jolawshi' poyezdi'ni'n' tezligi 1,5 km/min. Yeger jolawshi' poyezdi' ju'k poyezddi'n 21 minuttan keyin quwi'p wo'tse, ha'zir wolar arasi'ndagi' arali'q qansha?
916. Wa'layat sport jari'slari'nda 5842 woqi'wshi qatnasti'. Sportshi ul balalar sani' qi'z balalar sani'nan 268 ge arti'q. Jari'slarda neshe ul bala ha'm neshe qi'z bala qatnasqan?

41-§.

WONLI'Q BO'LSHEKLERDI NATURAL SANG'A BO'LIW

1- mi'sal. Uzi'nli'g'i' 16,8 m bolg'an gezleme 6 ten' bo'lekke bo'lindi. Ha'r bir bo'lek uzi'nli'g'i'n tabi'n'.

Sheshiliwi: Ma'seleni sheshiw ushi'n da'slep gezleme uzi'nli'g'i'n decimetrlerde an'latami'z: 16,8 m = 168 dm.

168 : 6 = 28 bolg'ani' ushi'n gezlemenin' bir bo'leginin' uzi'nli'g'i' 28 dm, yag'ni'y 2,8 m ge ten' boladi'.

Tekseriw: 2,8 di 6 g'a ko'beytsek 16,8 payda boladi'. Demek, tiyindi duri's tabi'lg'an.

Juwabi': Ha'rbir bo'lektin' uzi'nli'g'i' 2,8 m ge ten'.

Solay yetip, 16,8 di 6 g'a bo'lgende tiyindi 2,8 ge ten' boldi'.

Bul 16,8 : 6 = 2,8 ko'rinishinde jazi'ladi'.

Wonli'q bo'lshekti natural sang'a bo'liw dep, sonday sandi' tabi'wg'a ayti'ladi', woni' natural sang'a ko'beytkende berilgen bo'lshek payda bolsi'n.

Joqardag'i' ma'seledegi berilgenlerdi decimetrlerge wo'tkermesten de sheshiw mu'mkin.

2- mi'sal. 16,8 di 6 g'a "mu'yesh" usi'li'nda bo'leyik.

Buni'n ushi'n u'tirge itibar bermesten, 168 di 6 g'a "mu'yesh " usi'li'nda bo'lshek ha'm sannin' pu'tin bo'legin bo'liw tamamlang'annan son' tiyindige u'tir qoyi'w kerek boladi'. Son' bo'liwdi dawam yettiriw kerek boladi',

$$\begin{array}{r|l} 16,8 & 6 \\ \hline 12 & 2 \\ \hline 4 & \end{array}$$

Haqi'yqati'nda da, sannin' pu'tin bo'legin bo'liw tamamlandi'. Tiyindi de turg'an sannan keyin u'tir qoyami'z ha'm bo'liwdi dawam yetemiz.

$$\begin{array}{r|l} 16,8 & 6 \\ \hline 12 & 2,8 \\ \hline -48 & \\ \hline 48 & \\ \hline 0 & \end{array}$$

Wonli'q bo'lshekti natural sang'a bo'liw ushi'n

- woni'n' u'tirine itibar bermey natural sang'a bo'linedi;
- pu'tin bo'legin bo'liw tamamlang'annan son' tiyindige u'tir qoyi'ladi' ha'm bo'liw dawam yettiriledi.



Yeger wonli'q bo'lshektin' pu'tin bo'legi natural sannan kishi bolsa, tiyindinin' pu'tin bo'legi nolden ibarat boladi'.

Buni' to'mendegi mi'salda da ko'riw mu'mkin.

3- mi'sal. 1,84 ti 8 ge "mu'yesh" usi'li'nda bo'leyik.

Tu'sindiriw. Bo'liniwshinin' pu'tin bo'legi 1 ge ten' boli'p, wol bo'liwshiden kishi. Soni'n' ushi'n tiyindige

0 pu'tin qoydi'q ha'm woni' u'tir menen ajratti'q.

Son' bo'liwdi a'dettegidey dawam yettirdik ha'm

1,84 : 8 = 0,23 na'tiyjege keldik.

4- mi'sal. 41,85 ti 18 ge "mu'yesh" usi'li'nda bo'leyik.

Tu'sindiriw. Bo'liwshinin' barli'q cifrlari'n to'menge ali'p tu'sirgenimizden keyin de qaldi'qta 0 payda bolmadi'. Biraq, biz woni' bo'lshektin' won' ta'repine qansha 0 jazg'an menen bo'lshek wo'zgermesligin bilemiz. Sonnan kelip shi'g'i'p, bo'liwdi

$$\begin{array}{r|l} 1,84 & 8 \\ \hline 1,6 & 0,23 \\ \hline -24 & \\ \hline 24 & \\ \hline 0 & \end{array}$$

$$\begin{array}{r}
 41,850 \overline{) 18} \\
 \underline{36} \\
 58 \\
 \underline{54} \\
 45 \\
 \underline{36} \\
 90 \\
 \underline{90} \\
 0
 \end{array}$$

dawam yettiring ushi'n bo'liwshinin' won' ta'repine izbe-iz 0 lerd qoyi'p barami'z ha'm tiyindinin' keyingi cifrlari'n tawi'p barami'z. Keyingi sanlari'n tawi'p barami'z.

Bizning holda bitta 0 ni qo'yish yetarli bo'ldi.

Na'tiyjede $41,85 : 18 = 2,325$ yekenligin tapti'q.

5- mi'sal. 38,3 ti 10 g'a bo'leyik.

Bizge belgili, bo'liw a'meli ma'nisi boyi'nsha tiyindini 10 g'a ko'beytkende bo'liniwshi payda boli'wi' kerek. Sonday-aq, wonli'q bo'lshekti 10 g'a ko'beytkende bir

tan'ba won'g'a ji'lji'ydi'.

Demek, wonli'q bo'lshekti 10 g'a bo'lgende bir tan'ba shepk e ji'lji'ydi' yeken: $38,3 : 10 = 3,83$.

Kishi izertlew jumi'si'

- a) $21,9 : 10 = ?$ b) $21,9 : 100 = ?$ d) $21,9 : 1000 = ?$

tiyindilerdi tabi'n' ha'm na'tiyjeni ten'liktin' won' ta'repine jazi'n'.

Payda bolg'an u'sh ten'likti jaqsi'lap ko'zden wo'tkerin' ha'm to'mendegi sorawlarg'a izbe-iz juwap berin':

1) Ha'rbir mi'salda bo'liniwshi ha'm tiyindide u'tirler jag'dayi' bir-birinen qalay pari'q qi'ladi'?

2) Bo'liwshilerde neshe nol bar?

3) Birinshi mi'salda u'tir neshe tan'ba qaysi' ta'repke ji'lji'g'an? yekinshi mi'salda ne? U'shinshi mi'salda ne?

4) U'tirdin' neshe tan'ba ji'lji'wi' nege baylani'sli' boladi'?

Joqardag'i' sorawlarg'a berilgen juwaplarg'a tiykarlani'p, wonli'q bo'lshekti 10, 100, 1000 ha'm tag'i' basqa sanlarg'a bo'liw qag'i'ydasin da'lillen'. Bul – kishi izertlewin'iz juwmag'i' boladi'.

Yeger barli'q sorawlarg'a duri's juwap berip, duri's juwmaq shi'g'arg'an bolsan'i'z, to'mendegi ani'qlamani' qayta ashqan bolasi'z:



Wonli'q bo'lshekti 10, 100, 1000... ha'm tag'i' basqa sanlarg'a bo'liw ushi'n bo'liwshide birden keyin neshe nol bolsa, wonli'q bo'lshekkegi u'tirde de sonsha tan'ba shepke ji'lji'ti'w jetkilikli.

Bul qag'i'ya boyi'nsha to'mendegi tiyindilerdi an'sat tabami'z:

$35,6 : 10 = 3,56$ (onli'q bo'lsheklerdegi u'tirdi **1** tan'ba shepke ji'lji'tti'q),

$527,4 : 100 = 5,274$ (onli'q bo'lsheklerdegi u'tirdi **2** tan'ba shepke ji'lji'tti'q),

$2167,1 : 1000 = 2,1671$ (onli'q bo'lsheklerdegi u'tirdi **3** tan'ba shepke ji'lji'tti'q).

Wonli'q bo'lshekkin' pu'tin bo'legine u'tirdi ji'lji'ti'wda cifrlar jeterli bolmasa, aldin wonli'q bo'lshekkin' shep ta'repine jeterli noller jazi'ladi' (bilesiz, bul jag'dayda wonli'q bo'lshek wo'zgermeydi), son' u'tir ji'lji'ydi'. Buni' to'mendegi mi'salda ko'iwimiz mu'mkin:

6- mi'sal. $24,5 : 1000$ bo'liwdi yesaplayi'q.

Ko'rip turg'ani'n'izday $24,5$ tin' pu'tin bo'leginde 2 cifr bar, biz bolsa u'tirdi shep ta'repke 3 tan'ba ji'lji'tpaqshi'mi'z. Soni'n' ushi'n, aldin bo'lshekkin' shep

ta'repine bir nol qoyi'p, son' u'tirdi 3 tan'ba shepke ji'lji'tami'z. A'l'bette, bul jag'dayda tiyindinin' pu'tin bo'legi 0 ge ten' boladi': $24,5 : 1000 = 024,5 : 1000 = = 0,0245$; Geyde u'lken natural sanlar menen jumi's ko'rgende wolardi' mi'n'larda yamasa millionlarda an'lati'wg'a tuwra keledi.

7- mi'sal. 14 500 sandi' mi'n'larda an'latayi'q.

Buni'n' ushi'n 14500 sani'n 1000 g'a bo'lip, 1000 g'a ko'beytemiz (buni'n' menen sanni'n' ma'nisi wo'zgermeydi): $(14500 : 1000) \cdot 1000$. Qawsir'ma ishindegi san 14,5 ke ten'.

Demek, $14500 = 14,5 \cdot 1000$. Aqi'rg'i' ko'beytiwshi 1000 di' cifr menen yemes ati'n so'z benen jazami'z. Na'tiyjede, $14500 = 14,5$ mi'n' degen na'tiyjege kelemiz.

Tap sog'an uqsas, natural sandi' millionlarda an'latqanda da usi' usi'l qollani'ladi'. Ma'selen, $28\ 300\ 000 = (28\ 300\ 000 : 1\ 000\ 000) \cdot 1\ 000\ 000 = = 28,3 \cdot 1\ 000\ 000 = 28,3$ million.

Bazi' bir jag'daylarda berilgen a'piwayi' bo'lshekke ten' bolg'an wonli'q bo'lshekki bo'liw ja'rdeminde tabi'w mu'mkin. Basqasha yetip aytqanda, bo'liw ja'rdeminde a'piwayi' bo'lshekki wonli'q bo'lshekke aylandi'ri'w mu'mkin.

8- mi'sal. $\frac{3}{5}$ bo'lshekki wonli'q bo'lshekke aylandi'ri'n'.

Sheshiliwi: Bizge belgili, $\frac{3}{5}$ bo'lshek 3 ti 5 ke bo'lgende payda bolg'an tiyindi.

3 ti 5 ke "mu'yesh" usi'li'nda bo'lip, 0,6 wonli'q bo'lshekki payda yetemiz. Demek,

$$\frac{3}{5} = 0,6.$$

Sorawlarg'a juwap berin'!



1. Wonli'q bo'lshekki natural sang'a bo'liw degende neni tu'sinesiz?
2. Wonli'q bo'lshekki natural sang'a bo'liw qag'i'ydasin' ayti'n' ha'm woni' mi'sallarda tu'sindirip berin'.
3. Yeger bo'lshekkin' pu'tin bo'legi bo'liwshiden kishi bolsa, tiyindinin' pu'tin bo'legi nege ten' boladi'?
4. Wonli'q bo'lshek 10, 100, 1000 ha'm tag'i' basqa sanlarg'a bo'liw qag'i'ydasin' ayti'n' ha'm woni' mi'sallarda tu'sindirin'.
5. U'lken natural sanlar mi'n'larda ya'ki millionlarda qalay an'lati'ladi'? Mi'sallarda tu'sindirin'?

Klasta wori'nlanatug'i'n shi'ni'g'i'wlar



917. Uzi'nli'g'i' 26,8 m bolg'an si'm 8 ten' bo'lekke bo'lindi. Ha'r bir bo'lektin' uzi'nli'g'i'n tabi'n'. Ma'seleni aldi'n berilgenlerdi santimetrlerge wo'tkerip, son' wonli'q bo'lshekki natural sang'a bo'liw qag'i'ydasin' boyi'nsha sheshin'. Na'tiyjelerdi wo'z ara sali'sti'ri'n.

918. Tiyindini tabi'n':

- a) $42,3 : 9$; b) $121,6 : 4$; d) $93,15 : 23$; e) $18,27 : 7$;
f) $172,8 : 12$; g) $1\ 59,84 : 72$; h) $14,4 : 12$; i) $44,8 : 4$.

U'lgi: Usi' bapta sheshilgen 2- mi'sal.

919. Tiyindini tabi'n':

- a) $2,34 : 9$; b) $1,68 : 4$; d) $93,15 : 23$; e) $3,57 : 7$;
 f) $10,824 : 12$; g) $36,72 : 72$; h) $4,8 : 12$; i) $3,48 : 4$.

U'lg'i: Usi' bapta sheshilgen 3-mi'sal.

920. Tiiyindini tabi'n':

- a) $5,87 : 2$; b) $10,63 : 2$; d) $3,42 : 4$; e) $10,4 : 5$;
 f) $13,8 : 15$; g) $24,4 : 8$; h) $14,7 : 12$; i) $44,5 : 4$.

U'lg'i: Usi' bapta sheshilgen 4-mi'sal.

921. a) Elektr shaynek 1 saatta 1,2 kilovatt elektr quwati'n sari'playdi'. 1 litr suw bul shaynekte 5 minutda qaynaydi'. Bug'an neshe kilovatt-saat elektr energiyasi' sari'planadi'?

b) Elektr plita 1 saatta 1,5 kilovatt elektr quwati'n sari'playdi'. 1 litr suw plitada 13 minutta qaynaydi'. Bug'an neshe kilovatt-saat elektr energiyasi' sari'planadi'?

d) Joqari'dag'i' ma'selelerde 1 litr suwdi' qaynati'w neshe swm g'a tu'siwin yesaplan' (1 kilovatt-saat elektr energiyasi' bahasi' shama menen 50 swm). Suwdi' nede qaynati'w arzan yekenligi haqqi'nda juwmaq shi'g'ari'n'.

922. Yesaplan':

- a) $4,42 : 10$; $0,57 : 10$; $8,8 : 10$; $0,5 : 10$; $0,05 : 10$;
 b) $4,387 : 100$; $26,35 : 100$; $0,002 : 100$; $0,35 : 100$; $0,2 : 100$;
 d) $55,48 : 1000$; $9,8 : 1000$; $0,00091 : 1000$; $0,003 : 1000$; $0,52 : 10\ 000$.

923. a) 0,0003 sani' 0,3; 0,03; 0,003 sani'nan neshe ma'rte kishi?

b) 0,0 2481 sani' 24,81; 0,2481; 248,1 sani'nan neshe ma'rte kishi?

d) 0,0746 sani' 746, 0,746, 74,6 sanlari'nan neshe ma'r te kishi?

924. Su'wret boyi'nsha ten'leme du'zin' ha'm woni' sheshin':

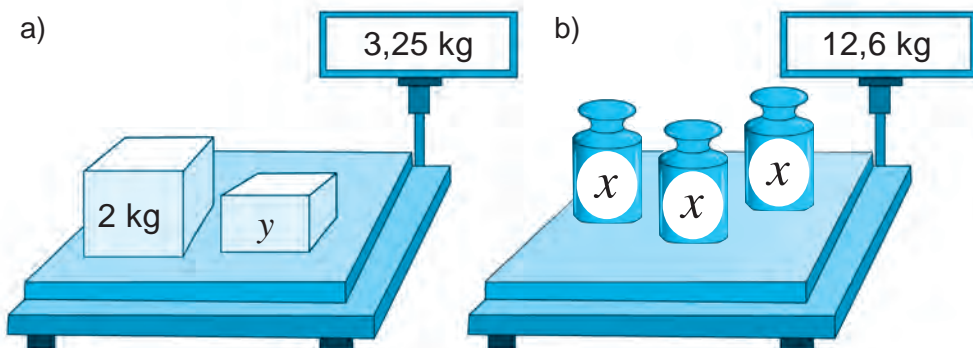

925. Bo'lshekti wonli'q ko'riniside an'lati'n':

- a) $\frac{3}{4}$; b) $\frac{5}{8}$; d) $\frac{7}{4}$; e) $\frac{83}{25}$; f) $5\frac{1}{2}$; g) $70\frac{3}{75}$.



U'lg'i: Usi' bapta sheshilgen 5-mi'sal.

- 926.** Ketekshelerdin' worni'na ko'beytiw yamasa bo'liw belgisin jazi'n'.
 a) $8,8 \square 10 = 88$; e) $44,55 \square 10 = 4,455$; h) $0,36 \square 100 = 36$;
 b) $7,5 \square 100 = 750$; f) $10,5 \square 10 = 1,05$; i) $3,78 \square 100 = 0,0378$;
 d) $3,3 \square 100 = 0,033$; g) $0,37 \square 10 = 3,7$; j) $5,18 \square 100 = 0,518$.
- 927.** Tu'sirilib qaldi'ri'Ig'an sanlardi' jazi'n'.
 a) $42,3 \cdot \dots = 423$; e) $8 : \dots = 0,08$; h) $0,007 \cdot \dots = 0,07$;
 b) $16,7 : \dots = 1,67$; f) $3,8 \cdot \dots = 380$; i) $0,6 : \dots = 0,06$;
 d) $0,05 \cdot \dots = 50$; g) $1,3 : \dots = 0,0013$; j) $1,3 : \dots = 0,13$.
- 928.** Sandi' millionlarda an'lati'n':
 a) 43 000 000; b) 8 900 000; d) 12 550 000; e) 674 345 000.
- 929.** Ten'izshiler arali'qti' ten'iz milinde yaki fudlarda wo'lsheydi. 1 ten'iz mili 6080 fud yamasa 1853,2 m ge ten'. a) 12 ten'iz mili neshe fudqa ten' boladi'?
 b) 3,6 ten'iz mili neshe m boladi'?
- 930.** A'yyemde adamlar arali'qti' shaqi'ri'mlarda wo'lshegen. Bir shaqi'ri'm 1066,78 m ge ten' bolg'an. 23 shaqi'ri'm neshe metrda quraydi'?
- 931.** Kompyuter monitori' tuwri'mu'yeshlik formasi'nda boli'p, woni'n' u'lkenligi tuwri'mu'yeshlik diaganali' uzi'nli'g'i'na sali'sti'ri'p dyumlarda wo'lshegedi. yeger 1 dyum 25,4 mm bolsa, a) 17; b) 21 dyumli' kompyuter manitori'ni'n' diaganali' neshe mm boladi'? Na'tiyjeni sm de an'lati'n'.
- 932.** Yeki quti'da 12,8 kg shay bar. Yeger birinshi quti'dan yekinshisine 0,04 kg shay ali'p sali'nsa, yeki quti'dag'i' shay massasi' ten'lesedi. Ha'r qaysi' quti'da qansha shay bar?
- 933.** Bir tuwri' to'rtmu'yeshliktin' ta'repleri 22 sm ha'm 4,8 sm. Yekinshi tuwri' to'rtmu'yeshliktin' maydani' birinshisinin' maydani'nan 11 ma'rte kishi. Yeger yekinshi tuwri' to'rtmu'yeshliktin' uzi'nli'g'i' 6 sm bolsa, woni'n' yenin tabi'n'.

U'yde wori'nlanatug'i'n ma'seleler



- 934.** Tiyindini tabi'n':
 a) $53,5 : 5$; b) $1,75 : 7$; d) $0,48 : 6$;
 e) $13,2 : 24$; f) $0,7 : 25$; g) $7,9 : 316$.
- 935.** An'latpani'n' ma'nisin tabi'n':
 a) $0,25 : 4 + 15,3 : 5 + 12,4 : 8 + 0,15 : 30$; b) $(1,24 + 3,56) : 16$;
 d) $2,28 + 3,72 : 12$; e) $3,6 + 2,4 : (11,71 - 3,71)$.
- 936.** Yesaplan':
 a) $6,387 : 100$; $226,35 : 100$; $0,005 : 100$; $0,65 : 100$; $0,9 : 100$;
 b) $85,48 : 1000$; $1,8 : 1000$; $0,00031 : 1000$; $0,004 : 1000$; $0,62 : 10\ 000$.
- 937.** a) 0,0 8431 sani' 84,31; 0,8431; 843,1 sani'nan neshe ma'rte kishi?
 b) 0,0125 sani' 1,25; 0,125; 12,5 sani'nan neshe ma'rte kishi?
- 938.** Sanlardi' mi'n'larda an'lati'n': 320 000; 75 000; 15 700; 365 240; 1 875 900.



939. Ten'lemeni sheshin':

a) $15x = 0,15$;

b) $3,08 : y = 4$;

d) $295,1 : (x - 3) = 13$;

e) $534 \cdot (x + 1,2) = 961,2$.

940. Du'kanda u'sh ku'nde 1240,8 kg un sati'ldi'. Birinshi ku'ni 543 kg, yekinshi ku'ni u'shinshi ku'ng'e qarag'anda 2 ma'rte ko'p un sati'ldi'. U'shinshi ku'ni neshe kg un sati'lg'an?

941. Bir qabaq neshe kilogramm?

a)



b)



942. U'sh wotlaqtan 28,6 t pishen jiynaldi'. Birinshi ha'm yekinshi wotlaqtan ten'dey, u'shinshi wotlaqtan bolsa aldi'ngi' yekewinin' ha'r birine qarag'anda 3,4 t artiq pishen jiynaldi'. Ha'r qaysi' wotlaqtan qansha pishen jiynalg'an?

943. Velosipedshi qaladan saati'na 13,4 km/saat tezlik penen jolg'a shi'qti'. Wonnan 2 saat keyin yekinshi velosipedshi jo'nedi ha'm 4 saatta yekinshi velosipedshige jetip aldi'. Yekinshi velosipedshinin' tezligin tabi'n'.

944. Kater ag'i'm boylap ha'reket yetip, 5 saatta 156,5 km jol basti'. Yeger katerdin' turg'i'n suwdag'i' tezligi 28,2 km/saat bolsa, da'rya ag'i'mi'ni'n tezligin tabi'n'.



Qi'ziqli' matematikag'a tiyisli ma'seleler

Bul bap materiallari'n u'yrenip shi'g'i'p to'mendegi ma'selelerdi sheshe ali'wi'n'i'z sha'rt! Qadag'alaw jumi'si' aldi'nan wo'zin'izdi si'nap ko'rin'.

- 1 2 3 = 1
- 1 2 3 4 = 1
- 1 2 3 4 5 = 1
- 1 2 3 4 5 6 = 1
- 1 2 3 4 5 6 7 = 1
- 1 2 3 4 5 6 7 8 = 1
- 1 2 3 4 5 6 7 8 9 = 1

Bilimin'izdi si'nap ko'rin'!



Bul bap materialлари'n u'yrenip shi'g'i'p to'mendegi ma'selelerdi sheshe ali'wi'n'i'z sha'rt! Qadag'alaw jumi'si' aldi'nan wo'zin'izdi si'nap ko'rin'!

10-qadag'alaw jumi's u'lgisi

1. Yesaplan':
 - a) $4,35 \cdot 18$;
 - b) $6,25 \cdot 108$;
 - d) $126,385 \cdot 10$;
 - e) $53,3 : 26$;
 - f) $6 : 24$;
 - g) $126,385 : 100$.
2. Ten'lemeni sheshin': $7y + 2,6 = 27,8$.
3. An'latpani'n' ma'nisin tabi'n': $90 - 16,2 : 9 + 0,08$.
4. Avtomobilge 8 bir qi'yli' quti' ha'm ha'r birinin' massasi' 0,28 t bolg'an 8 yashik ju'klendi. Yeger pu'tin ju'ktin' massasi' 2,4 t bolsa, bir quti'ni'n' massasi'n tabi'n'.
5. Birinshi ko'beytiwshide u'tir yeki tan'ba won'g'a, yekinshi ko'beytiwshide 4 tan'ba shepke ji'lji'ti'lsa, ko'beyme qalay wo'zgeredi?

Qi'ziqli' matematikag'a tiyisli ma'seleler



Si'yqi'rli' kvadratlar

Ra'wayat qi'li'wi'nsha, birinshi si'yqi'rli' kvadrat bunnan 7-8 mi'n' ji'l aldi'n Qi'tayda du'zilgen. Bul kvadrat tasbaqa kesesine jazi'lg'an boli'p, tasqa aylang'an tasbaqa ko'p a'sirlerden keyin tawi'p ali'ng'an (a-su'wret). Kvadrat 9 keteksheden ibarat boli'p, wonda 1 den 9 g'a shekem bolg'an cifrlar jazi'p qoyi'lg'an (b-su'wret).

Yekinshi si'yqi'rli' kvadrat bunnan mi'n' ji'l aldi'n Hindistanda du'zilgen. Woni'n' 16 ketekshesi bar boli'p, wog'an 1 den 16 g'a shekem bolg'an cifrlar jazi'lg'an (d-su'wret).

Bul kvadratlaridin' ha'rbir qatari', bag'ana ha'm diagonali'nda turg'an sanlardi' wo'z aldi'na qosi'p shi'g'i'n' ha'm wolardin' si'yqi'ri' nede yekenligin tabi'n':

a)

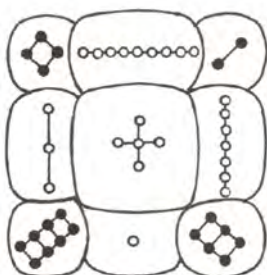

b)

4	9	2
3	5	7
8	1	6

d)

1	14	15	4
12	7	6	9
8	11	10	5
13	2	3	16

42- §.

WONLI'Q BO'LSHEKLERDI KO'BEYTIW

1- mi'sal. Tuwrimu'yeshlikтин' ta'repleri 3,6 sm ha'm 5,2 sm. Woni'n' maydani'n tabi'n'.

Sheshiliwi: Bul ma'seleni natural sanlardi' ko'beytiw qag'iydasi'nan paydalani'p sheshemiz. Buni'n' ushi'n berilgenlerdi millimetrde an'lati'p alami'z. 3,6 sm = 36 mm ha'm 5,2 sm = 52 mm. Yendi tuwri'mu'yeshlikтин' ta'replerin natural sanlarda an'lati'ladi'. Soni'n' ushi'n tuwri'mu'yeshlikтин' maydani' bul sanlardi'n' ko'beymesinen ibarat boladi': $36 \cdot 52 = 1872$ (mm²).

Payda bolg'an shamani' santimetrlerde an'latami'z:

$$1 \text{ sm}^2 = 100 \text{ mm}^2 \text{ bolg'ani' ushi'n, } 1 \text{ mm}^2 = \frac{1}{100} \text{ sm}^2 \text{ bo'ladi.}$$

$$\text{Demak, } 1872 \text{ mm}^2 = \frac{1872}{100} \text{ sm}^2 = 18\frac{72}{100} \text{ sm}^2 = 18,72 \text{ sm}^2.$$

Juwabi': Tuwri'mu'yeshlikтин' maydani' 18,72 sm² qa ten'ga teng.

Tap usi' na'tiyjeni, to'mendegi wonli'q bo'lsheklerdi ko'beytiw qag'iydasi'nan paydalani'p ta qolayli' usi'lda payda yetiw mu'mkin:



Yeki wonli'q bo'lshekti bir-birine ko'beytiw ushi'n

- u'tirlerge itibar berilmesten wolar ko'beytiledi;
- payda bolg'an ko'beymenin' won' ta'repinen, usi' yeki bo'lshekte birgelikte
- u'tirden keyin neshe cifr bolsa, sonsha cifr u'tir menen ajiri'ratiladi'.

2- mi'sal. Bul qag'iydag'a ko're 3,6 ni' 5,2 ge ko'beyteyik.

Tu'sindiriw. U'tirlerge itibar bermey 36 ha'm 52 sanlari'n ko'beytemiz:

$$\begin{array}{r} 3,6 \\ \times 5,2 \\ \hline 72 \\ + 180 \\ \hline 18,72 \end{array}$$

$36 \cdot 52 = 1872$ ni payda yetemiz.

Ha'r yeki ko'beytiwshide u'tirden keyin birewden, ja'mi 2 cifr bar.

Soni'n' ushi'n 1872 sani'ni'n' won' ta'repine

2 cifrdi' u'tir menen ajiri'ratami'z. Na'tiyjede, 18,72 ni payda yetemiz.

Ko'rip turg'ani'n'izday, ha'r yeki jag'dayda da birdey na'tiyjege keldik.

Yesletpe. Ko'beytiwshini "bag'ana" formasi'nda wori'nlawda qosi'wdag'i'day u'tir asti'na u'tir qoyi'li'wi' sha'rt yemes.

3- mi'sal. 13,12 · 1,8 ko'beymeni tabayi'q.

$$\begin{array}{r} 13,12 \\ \times 1,8 \\ \hline 10496 \\ + 1312 \\ \hline 23,616 \end{array}$$

Tu'sindiriw. Ko'beytiwshilerde u'tirden keyin ja'mi

3 cifr bar.

Soni'n' ushi'n ko'beymede de

3 cifrdi' u'tir menen ajiri'ratami'z.

Ayri'm jag'daylarda ko'beymenin' cifrlari'n u'tir menen ajirati'wda cifrlar jeterli bolmawi' mu'mkin. Bul jag'daylarda ko'beymenin' shep ta'repine kereginshe noller jazi'ladi'.



4- mi'sal. 0,034 ha'm 2,12 sanlari'n ko'beyteyik.

$$\begin{array}{r} \times 0,034 \\ \underline{2,12} \\ 68 \\ + 34 \\ \underline{68} \\ 0,07208 \end{array}$$

Tu'sindiriv.

34 ha'm 212 sanlari'ni'n' ko'beymesi 7208 ge ten'..

Ko'beytiwshilerde ja'mi u'tirden keyin

5 cifr bar bar. Ko'beymede bolsa 4 cifr bar.

5 cifrdi' u'tir menen ajrati'w ushi'n woni'n' shep ta'repine ja'ne bir 0 jazami'z ha'm u'tirdi qoyami'z. A'l'bette, bul jag'dayda tiyindinin' pu'tin bo'legi 0 ge ten' boladi'. Na'tiyjede, 0,07208 di payda yetemiz.

Wonli'q bo'lsheklarde de aldi'n u'yrenilgen ni'zamlar wori'nli' boladi'.

Wori'n almasti'ri'w ni'zami':

$$a \cdot b = b \cdot a$$

Gruppaw ni'zami':

$$(a \cdot b) \cdot c = a \cdot (b \cdot c)$$

Bo'listiriw ni'zami':

$$(a+b) \cdot c = a \cdot c + b \cdot c$$

Ko'beytiw ni'zamlari' geyde yesaplawlardi' biraz an'satlasti'radi'. Buni' to'mendegi mi'sallardan da ko'riwimiz mu'mkin:

5- mi'sal. 1) $(0,25 \cdot 7,23) \cdot 4 = (7,23 \cdot 0,25) \cdot 4 = 7,23 \cdot (0,25 \cdot 4) = 7,23 \cdot 1 = 7,23$;
2) $8,2 \cdot 3,7 + 1,3 \cdot 8,2 = 8,2 \cdot (3,7 + 1,3) = 8,2 \cdot 5 = 41$

Sorawlarg'a juwap berin'!



1. Wonli'q bo'lsheklardi ko'beytiw ni'zami'n ayti'n' ha'm woni' mi'sallarda tu'sindirip berin'.
2. Wonli'q bo'lsheklardi u'tirlerge itibar bermey ko'beytkende payda bolg'an ko'beymedegi u'tir qalay qoyi'ladi'?
3. Wonli'q bo'lsheklardi u'tirlerge itibar bermesten ko'beytkende payda olg'an ko'beymede cifrlardi' u'tir menen ajrati'wda cifrlar bolmasa ne qi'li'nadi'?
4. Wonli'q bo'lsheklarde de aldi'n u'yrenilgen ko'beytiw ni'zamlari' wori'nli' bola ma?

Klasta wori'nlanatug'i'n shi'ni'g'i'wlar



945. Qosi'ndi'ni' aldi'n ko'beymege keltirip yesaplan':

a) $4,3 + 4,3 + 4,3 + 4,3 + 4,3$; b) $1,25 + 1,25 + 1,25 + 1,25 + 1,25 + 1,25$.

946. Yesaplan':

a) $0,4 \cdot 0,6$;

b) $0,12 \cdot 0,5$;

d) $1,4 \cdot 0,2$;

e) $1,5 \cdot 0,8$;

f) $2,4 \cdot 0,3$;

g) $5,2 \cdot 0,4$;

h) $0,4 \cdot 12,6$;

i) $0,3 \cdot 1,6$;

j) $0,8 \cdot 0,12$.

947. To'mendegi sanlar ko'beymesinde u'tirden keyin neshe cifr boladi'?

a) $12,42 \cdot 0,621$;

b) $0,124 \cdot 45,5$;

d) $21,467 \cdot 6,002$;

e) $0,005 \cdot 1,8$;

f) $1,412 \cdot 0,033$;

g) $52 \cdot 0,403$;

h) $0,024 \cdot 12$;

i) $1,03 \cdot 1,68$;

j) $1,8888 \cdot 0,10002$.

948. Yeger $89 \cdot 73 = 6497$ yekenligi belgili bolsa, to'mendegi ko'beymeni yesaplan':

- a) $89 \cdot 7,3$; b) $0,89 \cdot 7,3$; d) $8,9 \cdot 73$;
 e) $8,9 \cdot 0,73$; f) $8,9 \cdot 0,073$; g) $8,9 \cdot 0,0073$;
 h) $0,89 \cdot 0,73$; i) $0,89 \cdot 73$; j) $89 \cdot 0,073$.

949. Ko'beytiwdi wori'nlan':

- a) $1,2 \cdot 1,6$; b) $0,21 \cdot 0,25$; d) $41,2 \cdot 0,2$;
 e) $0,04 \cdot 0,003$; f) $3,2 \cdot 2,4$; g) $0,99 \cdot 0,02$;
 h) $0,8 \cdot 0,12$; i) $15,2 \cdot 0,3$; j) $1,4 \cdot 1,01$.

950. Ko'beytiwdi wori'nlan':

- a) $6,25 \cdot 0,6$; b) $0,75 \cdot 1,2$; d) $0,412 \cdot 0,2$;
 e) $0,04 \cdot 0,003$; f) $0,32 \cdot 0,04$; g) $0,9 \cdot 0,02$;
 h) $0,8 \cdot 0,012$; i) $15,2 \cdot 0,003$; j) $1,4 \cdot 0,012$.

951. Yesaplan':

- a) $0,6^2$; b) $0,3^2$; d) $1,2^2$; e) $0,7^2$;
 f) $0,6^3$; g) $0,1^3$; h) $1,1^3$; i) $1,2^3$.

952. Ko'beytiwdi wori'nlan':

- a) $0,123 \cdot 1,6$; b) $0,21 \cdot 0,25$; d) $21,25 \cdot 2,21$;
 e) $0,14 \cdot 0,023$; f) $1,26 \cdot 2,41$; g) $2,99 \cdot 2,02$;
 h) $7,908 \cdot 0,4$; i) $0,752 \cdot 0,3$; j) $1,7 \cdot 1,601$.



953. Qolayli' usi'l menen yesaplan': ($0,5 \cdot 2 = 1$; $0,25 \cdot 4 = 1$; $0,125 \cdot 8 = 1$).

- a) $0,5 \cdot 5,38 \cdot 2$; b) $0,25 \cdot 12,63 \cdot 4$; d) $0,125 \cdot 0,823 \cdot 8$;
 e) $5 \cdot 57,2 \cdot 0,2$; f) $2,5 \cdot 0,23 \cdot 4$; g) $1,25 \cdot 17,2 \cdot 8$.

954. Qolayli' usi'l menen yesaplan':

- a) $1,2 \cdot 6,7 + 3,3 \cdot 1,2$; b) $21,3 \cdot 4,8 + 5,2 \cdot 21,3$; d) $3,2 \cdot 4,4 + 2,8 \cdot 4,4$;
 e) $67,2 \cdot 1,4 + 8,6 \cdot 67,2$; f) $8,9 \cdot 3,7 + 6,3 \cdot 8,9$; g) $0,2 \cdot 9,3 + 7,8 \cdot 0,2$;

955. a) 5,6; 0,854; 200; 5,8 sanlari'n 3,6 ma'rte artti'ri'n';

b) 3,06; 12,5; 23,01; 3,904 sanlari'n bolsa 2,8 ma'rte artti'ri'n'.

956. Tuwri'mu'yeshliktin' ta'repleri: a) 3,5 sm ha'm 4 sm; b) 4,3 sm ha'm 4 dm;

d) 8 m ha'm 2,66 m; e) 7,2 sm ha'm 12,9 sm bolsa, woni'n' uzi'nli'g'i'n' tabi'n'.

957. 1 kg qumsheker bahasi' 4200 swm. Ta'rezide tarti'lg'an qumsheker ushi'n neshe swm to'lengen?



958. Xana poli'ni'n' uzi'nli'g'i' 5,75 m; yeni 3,92 m. Poldi'n' maydani' nege ten'? Juwapti' kvadrat metrdin' wannan birine shekem do'n'geleklen'.

959. A'mellerdi wori'nlan':

- a) $(7 - 4,996) \cdot 20,5 - 17,993$; b) $0,18 \cdot (8,5 + 163,48) - 10,63$;
 d) $67,45 - 7,45 \cdot (3,8 + 4,2)$; e) $28,6 + 11,4 \cdot (6,595 + 3,405)$.



- 960.** 1 kg konfet 5800 swm turadi'. a) 2,3 kg; b) 1,2 kg; d) 0,8 kg; e) 0,2 kg konfet qansha turadi'?
- 961.** 1 sm³ temirdin' massasi' 7,9 g. Ko'lemi a) 4,9 sm³; b) 0,5 sm³ bolg'an temir bo'leginin' massasi'n tabi'n'.
- 962.** A'mellerdi wori'nlan':
 a) $20,4 \cdot 6,5 - 3,8 \cdot (7,16 - 3,615) + 41,9$;
 b) $(0,547 + 4,333) \cdot 0,305 - 0,205 - 70 \cdot 0,005$;
 d) $29,48 - 18,48 \cdot (10 - 9,35) + 0,75$;
 e) $100,1 - 10,1 \cdot (0,038 + 0,162) \cdot 0,69$.
- 963.** Yeger $a = 11,25$, $b = 12,25$ bolsa, $10,34a - 9,34b$ an'latpani'n' ma'nisin tabi'n'.
- 964.** Qolayli' usi'l menen yesaplan':
 a) $2,5 \cdot 1,03 \cdot 4$; b) $0,5 \cdot 79,6 \cdot 2$; d) $0,25 \cdot 0,5 \cdot 2 \cdot 4$;
 e) $0,2 \cdot 7,09 \cdot 5$; f) $2,5 \cdot 23,8 \cdot 4$; g) $1,25 \cdot 0,45 \cdot 8$.
- 965.** A'mellerdi wori'nlan':
 a) $2,5 \cdot 1,035 \cdot 4$; b) $7,5 \cdot 79,6 \cdot 0,4$; d) $3 \cdot 0,13 \cdot 0,5 \cdot 2$; e) $1,2 \cdot 7,09 \cdot 5 \cdot 10$. 
-
- 966.** Ko'beytiwdin' bo'listiriv ni'zami'n qollap, an'latpani'n' ma'nisin tabi'n':
 a) $64,52 \cdot 0,5039 + 35,48 \cdot 0,5039$; b) $6,305 \cdot 735,79 + 6,305 \cdot 264,21$;
 d) $204,56 \cdot 378,91 - 194,56 \cdot 378,91$; e) $0,87 \cdot 396,3 - 296,3 \cdot 0,87$.
- 967.** 2,5 kg konfet ha'm 2,3 kg peshenie sati'p ali'ndi'. Yeger 1 kg peshenie 1500 swm, konfettin' bahasi' peshenienikinen 1100 swm arti'q bolsa, bul sati'p ali'ng'an zatlar ushi'n qansha pul to'lengen?
- 968.** Uzi'nli'gi' 5,8 m, yeni 4,2 m ha'm biyikligi 2,85 m bolg'an bo'lme diywallari'ni'n' maydani'ni'n' qosi'ndi'si'n tabi'n'. Bo'lmenin' ko'lemin tabi'n'. Na'tiyjelerdi wonnan birge shekem do'n'geleklen'.
- 969.** Jer Quyash a'tirapi'nda 29,8 km/saat tezlikte aylanadi'. Planetami'z
 a) 4 sekundta; b) 5,8 sekundta; d) 23,4 sekundta; e) 1 minutta shama menen qansha jol basadi'?
- 970.** Qolayli' usi'l menen yesaplan:
 a) $3,4 \cdot 2,6 + 1,3 \cdot 2,6 + 5,3 \cdot 0,7 + 5,3 \cdot 1,9$;
 b) $3,6 \cdot 3,8 + 1,6 \cdot 1,6 + 2,7 \cdot 4,6 + 0,9 \cdot 4,6$;
 d) $1,7 \cdot 2,3 - 1,7 \cdot 1,5 + 0,8 \cdot 2,2 - 0,8 \cdot 0,5$;
 e) $2,5 \cdot 3,5 - 1,6 \cdot 2,5 + 1,9 \cdot 0,7 + 0,8 \cdot 1,9$.
- 971.** Yeger $8,9 \cdot 7,3 = 64,97$ yeklenligi belgili bolsa, to'mendegi ko'beymeni yesaplan':
 a) $89 \cdot 7,3$; b) $8,9 \cdot 73$; d) $8,9 \cdot 0,73$;
 e) $8,9 \cdot 0,73$; f) $8,9 \cdot 0,0073$; g) $89 \cdot 0,73$;
 h) $0,89 \cdot 0,73$; i) $890 \cdot 7,3$; j) $8,9 \cdot 730$.





U'yde wori'nlanatug'i'n shi'ni'g'i'wlar

- 972.** To'mendegi sanlar ko'beymesinde u'tirden keyin neshe cifr boladi'?
- a) $23,43 \cdot 0,632$; b) $32,464 \cdot 6,03$; d) $0,006 \cdot 2,01$;
 e) $63 \cdot 0,0403$; f) $0,034 \cdot 23$; g) $2,111 \cdot 0,20003$.
- 973.** Ko'beytiwdi wori'nlan':
- a) $42,2 \cdot 0,2$; b) $22,6 \cdot 0,01$; d) $0,66 \cdot 0,02$;
 e) $0,23 \cdot 22$; f) $2,4 \cdot 2,02$; g) $0,33 \cdot 0,003$.
- 974.** Ko'beytiwdi wori'nlan':
- a) $28,16 \cdot 7,12$; b) $2,6 \cdot 0,801$; d) $2,99 \cdot 8,02$;
 e) $0,53 \cdot 21,002$; f) $2,4 \cdot 1,605$; g) $1,33 \cdot 9,32$.
- 975.** Yeger $29 \cdot 48 = 1392$ yekenligi belgili bolsa, to'mendegi ko'beytiwdi yesaplan':
- a) $0,29 \cdot 4,8$; b) $2,9 \cdot 48$; d) $2,9 \cdot 0,048$;
 e) $2,9 \cdot 0,0048$; f) $0,29 \cdot 48$; g) $29 \cdot 0,048$.



- 976.** Tuwri'mu'yeshlik ta'repleri: a) 5,3 sm ha'm 6 sm; b) 3,4 sm ha'm 2 dm; d) 6 m ha'm 3,56 m; e) 8,5 sm ha'm 24,7 sm bo'lsa, uning yuzini toping.
- 977.** Mars planetasi' Quyash a'tirapi'nda sekundi'na 24,1 km tezlikte aylanadi'. Mars: a) 5 sekundda; b) 3,2 sekundda; d) 12,8 sekundda; e) 1 minutta qansha joldi basi'p wo'tedi?
- 978.** Mektep kolidori'ni'n' uzi'nli'g'i' 30,24 m, yeni 6,12 m. Mektep kolidori'ni'n' uzi'nli'g'i'n' tabi'n'. Juwapti' ju'zden birge shekem do'n'geleklen'.
- 979.** An'latpani'n' ma'nisin tabi'n':
- a) $308,6 \cdot 0,5 + 8,3 \cdot 4,5 - 3,5 \cdot (72 - 71,4)$;
 b) $0,625 \cdot 600 - 100 \cdot (6,1 - 3,16) + 0,92$;
 d) $125,61 - (3,67 - 2,38) \cdot (3,67 + 2,38) - 40,49$;
 e) $391,6 - 21,5 \cdot (0,38 + 0,25) \cdot 0,6 - 51,38 \cdot 3,45$.



- 980.** Hayal du'kannan 3,5 kg gu'rish ha'm 0,8 kg konfet sati'p aldi'. Yeger 1 kg gu'rish bahasi'—2800 swm, 1 kg konfet bahasi' bolsa 3850 swm bolsa, hayal sati'p alg'an zatlari' ushi'n neshe swm to'legen?
- 981.** Bir kub metr paxtani'n' massasi' 0,08 t, 1 m³ topi'raqti'n' massasi' 1,76 t. 0,75 m³ topi'raq ya'ki 15,8 m³ paxta awi'r ma?
- 982.** An'latpani'n' ma'nisin tabi'n':
- a) $2,945x + 1,549x - 20,9$, bunda $x = 22$;
 b) $6,002a - 2,25a + 8,11$, bunda $a = 16$.
- 983.** A'mellerdi wori'nlan':
- a) $2076 + 456 \cdot 532 - 185\,060 : 487$; b) $4621 - 53\,856 : 396 + 119 \cdot 244$;
 d) $2103 \cdot 84 - 89\,364 + 190\,114 : 38$; e) $81\,108 : 27 + 91\,687 - 1305 \cdot 65$.



- 984.** Qariydarda 172 000 swm bar yedi. Wol toppi' ha'm woramal sati'p aldi'. Toppi' ushi'n barli'q puldi'n' 0,1 bo'legin, woramal ushi'n bolsa barli'q puldi'n' 0,01 bo'legin sari'pladi'. Qariydarda qansha pul qaldi'?
- 985.** Yeger $2,9 \cdot 4,3 = 12,47$ yekenligi belgili bolsa, to'mendegi ko'beymeni yesaplan':
- | | | |
|-----------------------|------------------------|-----------------------|
| a) $29 \cdot 4,3;$ | b) $2,9 \cdot 43;$ | d) $2,9 \cdot 0,43 ;$ |
| e) $2,9 \cdot 0,43;$ | f) $2,9 \cdot 0,0043;$ | g) $2,9 \cdot 430;$ |
| h) $0,29 \cdot 0,43;$ | i) $290 \cdot 4,3;$ | j) $29 \cdot 0,43.$ |
- 986.** Qolayli' usi'l menen yesaplan':
- a) $3,4 \cdot 1,6 + 2,3 \cdot 1,6 + 4,3 \cdot 0,7 + 4,3 \cdot 0,9;$
 b) $5,6 \cdot 3,8 + 5,6 \cdot 1,6 + 2,7 \cdot 4,6 + 2,9 \cdot 4,6;$
 d) $0,7 \cdot 2,3 - 0,7 \cdot 1,5 + 0,8 \cdot 1,2 - 0,8 \cdot 0,5;$
 e) $6,5 \cdot 2,5 - 1,6 \cdot 6,5 + 0,9 \cdot 0,7 + 0,8 \cdot 0,9.$
- 987.** Uzi'nli'g'i' 7,2 m, yeni 5,1 m ha'm biyikligi 3,24 m bolg'an bo'lme diywallari'ni'n' maydani'ni'n' qosi'ndi'si'n tabi'n'. Bo'lmenin' ko'lemin tabi'n'. Na'tijelardi wonnan birge shekem do'n'geleklen'.
- 988.** Tashkent teleminarasi'nda tamasha maydani' 120 m biyiklikte jaylasqan. Yeger teleminara biyikligi tamasha maydani' biyikliginen 3,125 ma'rte uzi'n bolsa, imaratti'n' biyikligin tabi'n'.
- 989.** Bir a'piwayi' lampa bir ji'lda – 219 kilovatt-saat, energiyani' tejewshi ilyuminecent lampa bolsa 43,8 kilovatt-saat elektr energiyani sari'playdi'. Yeger a'piwayi' lampa worni'na energiyani tejewshi lampa isletilse, shan'araq bir ji'lda neshe swmdi' tejeydi? (1 kilovatt-saat elektr energiya bahasi' 144,3 swm).
- 990.** Yeger shan'araq kunine 4 kilovatt-saat elektr energiyani' tejeje, a) bir ayda; b) bir ji'lda bul shan'araq neshe swm tejeydi? (1 kilovatt-saat elektr energiya bahasi' 144,3 swm).



Qi'ziqli' matematikag'a tiyisli ma'seleler



U'sh birdey alma to'rt birdey almurttan awi'r. 4 alm ya'ki 5 almurt awi'r ma?

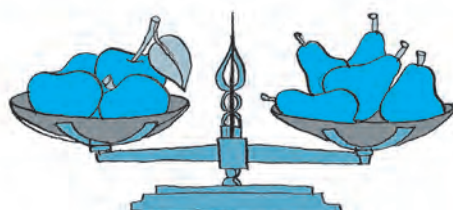
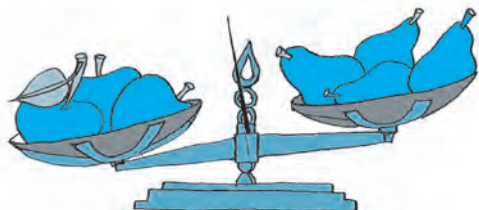

43- §.

WONLI'Q BO'LSHEKKE BO'LIW

1- *mi'sal.* Tuwri'mu'yeshliktin' maydani' 3,12 dm², uzi'nli'g'i' 2,6 dm. Tuwri'mu'yeshliktin' yenin' uzi'nli'g'i'n' tabi'n'.

Sheshiliwi. Tuwri'mu'yewshliktin' maydani'n' tabi'w ushi'n $S = a \cdot b$ formuladan paydalanami'z. Sha'rt boyi'nsha, $S = 3,12 \text{ dm}^2$, $a = 2,6 \text{ dm}$ berilgen. b ni' tabi'wi'mi'z kerek.

$3,12 \text{ dm}^2 = 312 \text{ sm}^2$ ha'm $2,6 \text{ dm} = 26 \text{ sm}$ bolg'ani' ushi'n tuwri'mu'yeshlik yeni $b = S : a = 312 : 26$ yaki $b = 12 \text{ sm} = 1,2$ ge ten' boladi'.

Biz sonday 1,2 sandi' tapti'q, woni' 2,6 g'a ko'beycek: $1,2 \cdot 2,6 = 3,12$ boladi'.

Demek, bul san 3,12 ni 2,6 g'a bo'lgende payda bolatug'i'n' tiyindiden ibarat boladi' ha'm bul $3,12 : 2,6 = 1,2$ tu'rinde jazi'ladi'.

Bul na'tiyjeni decimetrlerdi santimetrlerge wo'tkizbesten de payda yetiw mu'mkin. Buni'n' ushi'n bo'liniwshi 3,12 ni de, bo'liwshi 2,6 da 10 g'a ko'beytip (yag'ni'y wolardag'i' u'tirlerdi won'g'a bir cifrg'a ji'li'sti'ri'p) 31,2 ni 26 g'a bo'liw jeterli 31,2 wonli'q bo'lshekti natural san 26 g'a bo'lip, ja'ne aldi'n'g'i' na'tiyjeni payda yetemiz: $31,2 : 26 = 1,2$.

- ! Sandi' wonli'q bo'lshekke bo'liw ushi'n:
- bo'liwshide u'tirden keyin neshe cifr bolsa, bo'liniwshide de, bo'liwshide de u'tir sonsha tan'ba won'g'a ji'li'sti'ri'ladi';
 - son' bo'liw wonli'q bo'lshekti natural sang'a bo'lgan si'yaqli' a'melge asi'ri'ladi'.

2- *mi'sal.* 19,376 ti 3,46 g'a bo'leyik.

Bo'liwshi 3,46 da da u'tirdi won'g'a 2 tan'bag'a ji'li'sti'rami'z. Na'tiyjede, 1937,6 ha'm 346 sanlari'n' payda yetemiz. wonli'q bo'lshekti natural sang'a bo'liw jag'dayi'na keldik. Bo'liwdi wori'nlap, $1937,6 : 346 = 5,6$ yekenligin tabami'z. Demek, 19,376 ni'n' 3,46 g'a tiyindisi de 5,6 g'a ten' boladi': $19,376 : 3,46 = 5,6$.

Juwabi': 5,6.

3- *mi'sal.* 4,3 ti 0,215 ke bo'leyik.

Bul jerde bo'liniwshide de ha'm bo'liwshide de u'tirdi 3 tan'ba won'g'a ji'lji'ti'w kerek. Bo'liniwshide u'tirden keyin bir cifr bolg'ani' ushi'n woni'n' won' ta'repine yeki nol jazami'z. U'tirdi ji'lji'tqannan keyin 4300 ha'm 215 sanlardi' payda yetemiz ha'm bo'liwdi wori'nlaymi'z. $4300 : 215 = 20$ bolg'ani' ushi'n $4,3 : 0,215 = 20$ g'a ten' boladi'.

Juwabi': 20.

4- *mi'sal.* 5,248 di 0,01 ge bo'leyik.

Bo'liniwshi 55,248 de de, bo'liwshide 0,01 de de u'tirdi 2 tan'ba won'g'a ji'li'sti'ri'p, $524,8 : 1 = 524,8$ di payda yetemiz. Demek, $5,248 : 0,01 = 524,8$.

Bunnan to'mendegi qag'i'ydag'a kelemiz.

Juwabi': 524,8.

! Wonli'q bo'lshek ha'mde 0,1; 0,01; 0,001 h.t.b (bir neshe noller ha'm 1 den ibarat) sanlardi'n' tiyindisin tabi'w ushi'n wonli'q bo'lshekтеgi u'tirdi bul sanlarda birden aldi'n' neshe nol turg'an bolsa, sonday tan'ba won'g'a ji'li'sti'ri'w jetkilikli.

Yeger noller jetpese, aldi'n' wonli'q bo'lshek aqi'ri'na kereginshe nollerdi jazi'w kerek.

Mi'sali', $39,12 : 0,0001 = 39,1200 : 0,0001 = 391200$.

Wonli'q bo'lshekti 0,1; 0,01; 0,001 h.t.b sanlarga bo'liw – woni' sa'ykes tu'rde 10, 100, 1000 h.t.b sanlarga ko'betiw degeni.



Kerinshe, wonli'q bo'lshekti 10, 100, 1000 h.t.b sanlarga bo'liw – woni' sa'ykes tu'rde 0,1; 0,01; 0,001 h.t.b sanlarga ko'betiw degeni.

Sorawlarg'a juwap berin'



1. Wonli'q bo'lsheklerdi bo'liw qag'i'ydasin ayti'n' ha'm woni' mi'sallarda tu'sintirip berin'.
2. Wonli'q bo'lshekti u'tirlerge itibar bermesten bo'lgende payda bolg'an tiyindidegi u'tir qalay qoyiladi'?
3. Bo'lshek sandi' 0,1; 0,01; 0,001 h.t.b sanlarga bo'liw qalay a'melge asiri'ladi'?
4. Bo'lshek sandi' 10, 100, 1000 h.t.b sanlarga bo'liw qalay a'melge asiri'ladi'?

Klasta wori'nlanatug'i'n shi'ni'g'i'wlar



991. Yesaplan':

- | | | | |
|----------------|----------------|--------------|-----------------|
| a) $0,9 : 3$; | b) $7,5 : 3$; | d) $1 : 2$; | e) $1,8 : 6$; |
| f) $4,5 : 3$; | g) $2,4 : 3$; | h) $3 : 2$; | i) $0,54 : 2$. |

992. Tu'sirilip qaldi'ri'lg'an sanlardi' ayti'n':

- | | | |
|----------------------------|---------------------------|----------------------------|
| a) $3 \cdot \dots = 3,6$; | b) $2 \cdot \dots = 5$; | d) $\dots \cdot 2 = 0,8$; |
| e) $10 \cdot \dots = 3$; | f) $0,3 : \dots = 0,03$; | g) $\dots : 0,3 = 3$; |
| h) $\dots : 0,5 = 2$; | i) $5 : \dots = 2$; | j) $0,9 : \dots = 0,09$. |

993. Bo'liwdi wori'nlan':

- | | | |
|-------------------|--------------------|--------------------|
| a) $17,4 : 0,6$; | b) $30,6 : 0,9$; | d) $17,28 : 7,2$; |
| e) $4,95 : 1,5$; | f) $0,343 : 0,7$; | g) $1,624 : 5,6$; |
| h) $3,36 : 1,5$; | i) $8,46 : 1,2$; | j) $10,01 : 9,1$. |

994. Bo'liwdi wori'nlan':

- | | | |
|---------------------|--------------------|----------------------|
| a) $512 : 0,16$; | b) $198 : 0,036$; | d) $12,25 : 0,005$; |
| e) $15,3 : 0,015$; | f) $81,2 : 0,35$; | g) $1050 : 4,2$. |

995. Bo'liwdi wori'nlan':

- | | | |
|---------------------|--------------------|--------------------|
| a) $8,9 : 0,4$; | b) $3,08 : 0,05$; | d) $77,7 : 0,37$; |
| e) $0,2106 : 3,9$; | f) $1,23 : 0,6$; | g) $28,42 : 1,4$; |
| h) $11,1 : 0,04$; | i) $0,04 : 2,5$; | j) $3,534 : 0,5$. |

996. Bo'liwdi wori'nlan'

- | | | |
|--------------------|---------------------|-------------------|
| a) $12 : 0,3$; | b) $6 : 0,6$; | d) $15 : 0,1$; |
| e) $48 : 0,8$; | f) $0,35 : 0,007$; | g) $1,6 : 0,2$; |
| h) $0,24 : 0,12$; | i) $0,3 : 0,3$; | j) $0,15 : 0,5$. |

997. Yesaplan'. Na'tiyjeni ko'beytiw arqali' tekserin':

- | | | |
|---------------------|--------------------|---------------------|
| a) $8,04 : 6,7$; | b) $1,072 : 0,8$; | d) $0,945 : 1,8$; |
| e) $70 : 5,6$; | f) $14,23 : 0,1$; | g) $0,24 : 0,001$; |
| h) $12,24 : 0,12$; | i) $9,39 : 0,3$; | j) $15,15 : 0,5$. |



998. Abdi'rahmanni'n' qa'deminin' uzi'nli'g'i' 0,45 m. Wol 54 m jol ju'riwi ushi'n neshe qa'dem taslawi' kerek?
999. Bo'liwdi wori'nlan':
 a) $54,0204 : 4,2$; b) $0,45716 : 0,22$; d) $11,648 : 5,6$; e) $105,3535 : 3,5$;
 f) $1 : 0,8$; g) $3 : 0,75$; h) $10 : 2,5$; i) $1 : 12,5$.
1000. Yeger: a) $a = 2,3712$, $b = 1,45$, $d = 0,31$; b) $a = 0,273$, $b = 4,38$, $d = 4,12$ bolsa, $M = a : (b - d)$ formula boyi'nsha M ni'n' ma'nisin tabi'n'.

1001. A'mellerdi wori'nlan':

- a) $(131,4 - 80,8) : 2,3 - 21,84$; b) $8,16 : (1,32 + 3,48) - 0,345$.

1002. Qi'mbat bahali' taslardi' tarti'wda massa birligi – karat qollani'ladi'. Bir karat 0,2 grammg'a ten'. Yeger almaz 0,9 g bolsa, woni'n' massasi'n qarata an'lati'n'.

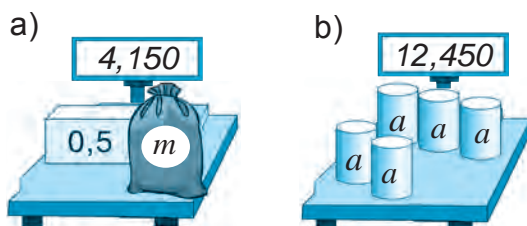

1- su'wret

1003. Ma'sh yegiwde 0,24 ga jerge 0,03 t da'n sebildi. 2 t da'ndi qanday maydang'a sebiw mu'mkin?



1004. 1-su'wretke qarap ten'leme du'zin' ha'm woni' sheshin'.

1005. Ten'lemeni sheshin':

- a) $1000 - 0,708x = 999,57166$; b) $(x + 26,1) \cdot 2,3 = 70,84$;
 d) $(x - 1,2) : 0,604 = 21,14$; e) $(10,49 - a) : 4,02 = 0,805$;
 f) $8,2x - 4,4x = 38,38$; g) $9a - 8,67a = 0,6699$.

1006. Qalayi'dan yeki buyi'm quyi'ldi'. Birinshi buyi'mg'a $6,3 \text{ sm}^3$, yekinshisine $4,9 \text{ sm}^3$ qalayi' ketti. Yeger kishi buyi'mni'n' massasi' 22,05 g bolsa, u'lken buyi'mni'n' massasi' qansha?

1007. Tashkentten Samarqandqa shekem bolg'an arali'q 300 km. Bul arali'qti' «Afrosiyob» tez ju'rer poyezdi' 2 saat 30 minutta basi'p wo'tedi. «Afrosiyob» tez ju'rer poyezdi'ni'n' tezligin tabi'n'.



1008. An'latpalardi'n' ma'nisin sali'sti'ri'n':

- a) $307,495 - 87,495 : (31,7 - 3,2)$ ha'm $29,8 \cdot 105$;
 b) $67,75 \cdot 3,81 + 32,25 \cdot 3,81$ ha'm $380 \cdot 1,976 - 380 \cdot 0,976$.

1009. Qa'teni tabi'n' ha'm duri's ten'likti jazi'n':

- a) $2,58 : 1,2 = 258 : 12$; b) $9,12 : 0,3 = 9,12 : 3$.



1010. An'latpani'n' ma'nisin tabi'n':

- a) $12,444 : (7 - 2,92) + 1,03 \cdot (13,65 - 3)$;
 b) $0,56994 : (1 - 0,195) - 0,28623 : (1 - 0,594)$;
 d) $(3,4 : 17 + 1,7 : 34) \cdot 4,2 + 8,25 : 3$;
 e) $((4,1 - 2,5 + 1,07 - 0,08) \cdot 0,41 \cdot 5) : 0,41$.

1011. Ko'lemi 50 sm^3 bolg'an alyumin shardi'n' massasi' 135 g. Yeger 1 sm^3 alyuminnin' massasi' 1 sm^3 temirdin' massasi'nan 5,2 g kem bolsa, sonday ko'lemdegi temir shardi'n' massasi' qansha bolad?

1012. Qaysi' jag'dayda arzan sawda a'melge asi'ri'ladi'?

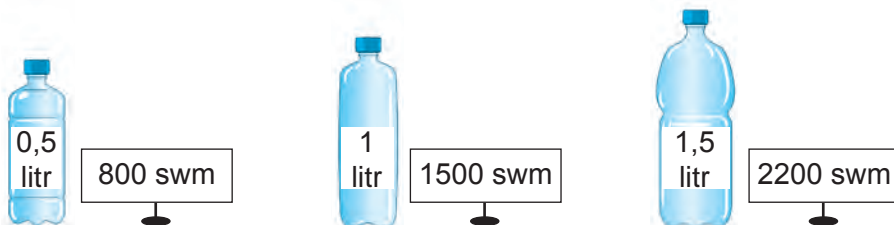

1013. Bo'liwdi wori'nlan':

- a) $37,4 : 0,1$; || b) $80,62 : 0,1$; || d) $1,981 : 0,1$; || e) $234,9 : 0,01$;
 f) $1,02 : 0,01$; || g) $15,164 : 0,01$; || h) $2,1306 : 0,001$; || i) $38,411 : 0,001$.

1014. Bo'liwdi wori'nlan':

- a) $3,7 : 0,1$; || b) $6,2 : 0,1$; || d) $191 : 0,1$; || e) $24,9 : 0,01$;
 f) $1,2 : 0,01$; || g) $15 : 0,01$; || h) $2,1 : 0,001$; || i) $8,41 : 0,001$.

1015. Tu'sirip qaldi'ri'lg'an sandi' jazi'p, tiyindini ko'beyme ko'rinisine keltirin' ha'm ko'beymeni yesaplan:

- a) $5,1 : 0,1 = 5,1 \cdot \dots$; || b) $3,1 : 0,1 = 3,1 \cdot \dots$; || d) $1,2 : 0,01 = 1,2 \cdot \dots$;
 e) $6,1 : 0,01 = 6,1 \cdot \dots$; || f) $11,2 : 0,001 = 11,2 \cdot \dots$; || g) $21,9 : 0,001 = 21,9 \cdot \dots$.

1016. Bir a'piwayi' lampa bir ji'lda – 219 kilovatt-saat, energiyani' tejewshi ilyuminecent lampa bolsa 43,8 kilovatt-saat elektr energiyani sari'playdi'. Yeger a'piwayi' lampa worni'na energiyani tejewshi lampa isletilse, shan'araq bir ji'lda neshe swmdi' tejeydi?

1017. 1 litr suwdi' elektr shaynekte qaynati'w $14,4 \text{ swmg'a}$, elektr plitkada qaynati'w – $46,8 \text{ swmg'a}$ tu'sedi. Elektr shaynekti isletiw elektr plitkag'a qarag'anda neshe ma'rte arzan?

U'yde wori'nlanatug'i'n ma'seleler



1018. Bo'liwdi wori'nlan':

- a) $47,2 : 0,2$; || b) $25,92 : 7,2$; || d) $5,55 : 1,5$;
 e) $2,688 : 5,6$; || f) $2,85 : 1,5$; || g) $13,65 : 9,1$.

1019. Bo'liwdi wori'nlan':

- a) $192 : 0,16$; || b) $684 : 0,036$; || d) $22,25 : 0,005$;
 e) $15,6 : 0,015$; || f) $45,5 : 0,35$; || g) $2142 : 4,2$.

1020. Bo'liwdi wori'nlan':

- a) $2,7 : 0,4$; b) $92,5 : 0,37$; d) $0,2184 : 3,9$;
 e) $42,42 : 1,4$; f) $21,3 : 0,04$; g) $0,536 : 0,5$.



1021. Bo'liwdi wori'nlan':

- a) $34 : 1,7$; b) $19 : 0,01$; d) $42 : 0,6$;
 e) $6,8 : 0,02$; f) $0,48 : 0,06$; g) $0,75 : 0,5$.

1022. Bo'liwdi wori'nlan':

- a) $54,0204 : 4,2$; b) $0,45716 : 0,22$; d) $105,3535 : 3,5$;
 e) $1 : 0,8$; f) $10 : 2,5$; g) $3 : 6,25$.

1023. Bo'liwdi wori'nlan':

- a) $133,111 : 2,2$; b) $2639,58 : 8,7$; d) $46,98 : 1,16$;
 e) $421 : 1,6$; f) $48 : 0,75$; g) $9 : 0,45$.



1024. Do'n'gelek shen'berinin' uzi'nli'g'i' 1,5 m. Do'n'gelek 20,5 ma'rte aylang'anda qansha arali'qti' basi'p wo'tedi? Do'n'gelek 231 m arali'qti' basi'p wo'tkende neshe ma'rte aylanadi'?

1025. Diyqan 0,35 ga jerge 0,021 t da'n septi. 0,3 t sonday da'ndi qansha maydang'a sebiw mu'mkin?

1026. Ten'lemeni sheshin':

- a) $1,936 : x = 3,2$; b) $1,48a = 30,34$; d) $b : 8,04 = 5,05$; e) $30,3 : k = 30$.



1027. Quri'li'sqa 24 000 dana gerbish keltirildi. Si'ng'an gerbishler barli'q gerbishtin' 0,015 bo'legin quraydi'. Quri'li'sqa neshe pu'tin gerbish keltirildi?

1028. Yesaplan'. Na'tiyjeni ko'beytiw arqali' tekserin':

- a) $7,65 : 1,7$; b) $3,848 : 0,8$; d) $0,414 : 1,8$; e) $84 : 5,6$;
 f) $44,56 : 0,1$; g) $0,31 : 0,001$; h) $60,24 : 0,12$; i) $15,39 : 0,3$.

1029. A'mellerdi wori'nlan':

- a) $0,21 : 5 + 3,17 : 8 - 2,22 : 16 + 3,7 : 4$;
 b) $(15,94 + 17,54) : (10,96 + 16,04) \cdot 3,72 - 1,901$.

1030. Xa'zireti Imam meshiti minarasi'ni'n' biyikligi 59 m boli'p, wol Minor meshiti minarasi'nan 1,18 ma'rte biyik. Minor meshitinin' biyikligin tabi'n'.



44- §.

ARIFMETIKALI'Q WORTASHA

Ku'ndelik turmi'sta siz gazeta ha'm jurnallardan, radio ha'm televideniyeden ha'mde internet saytlari'nan wortasha payda, wortasha ayli'q, wortasha ku'nlik basi'm, xali'qti'n' wortasha jasi', bahalardi'n' wortasha wo'siwi, wortasha miynet wo'nimdarli'gi' wortasha wo'zlestiriv siyaqli' wortasha mug'darlar haqqi'nda woqi'g'an ya yesitken boli'wi'n'i'z kerek. Bul qanday mug'darlar, wolar qalay tabi'ladi' ha'm wolardi' biliw ne ushi'n kerek? To'mende sol haqqi'nda toqtalami'z.

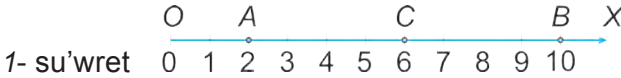

1-su'wrettegi sanlar nuri'nda $A(2)$ ha'm $B(10)$ noqatlar berilgen. Bul noqatardi'n' qaq wortasi'nda jaylasqan C noqati'ni'n' koordinatasi' 6'g'a ten' boli'p, wol A ha'm B noqatlar koordinatalari' arqali to'mendegishe tabi'ladi': $\frac{2 + 10}{2} = 6$. Bul jerde 6 sani' 2 ha'm 10 sanlari'ni'n' worta arifmetigi dep ataladi'.

Bir neshe sanlardi'n' *arifmetikal'q wortashasi'* dep, bul sanlar qosi'ndi'si'n wolardi'n' sani'na bo'liw na'tiyjesine ayti'ladi'.

U'sh a , b ha'm c *sanlari'ni'n' arifmetikal'q wortashasi'n* tabi'w ushi'n bul sanlar qosi'ndi'si' $(a + b + c)$ ni' wolardi'n' sani' 3 ke bo'liw jetkilikli:

$$\boxed{\textit{a, b ha'm c sanlari'ni'n' arifmetikal'q wortashasi'}} = \frac{(a + b + c)}{3} \begin{matrix} \leftarrow \textit{sanlar qosi'ndi'si'} \\ \leftarrow \textit{wolardi'n' sani'} \end{matrix}$$

1-mi'sal. Alisher bali'q awi'n'a shi'qti. Wol birinshi saatta 6 dana, yekinshi saatta 11 dana ha'm u'shinshi saatta 10 dana bali'q wovladi'. Alisher bir saatta wo'rtasha nesh bali'q awlag'an?

Sheshiliwi: Alisher 3 saat dawami'nda ha'mmesi boli'p $6 + 11 + 10 = 27$ bali'q awlag'an. Wol bir satta wortasha $27 : 3$, yag'ni'y 9 dan bali'q awlag'an.

Juwabi': Alisher bir saatta wortasha 9 dan bali'q awlag'an.

Bir neshe sanlardi'n' arifmetikal'q wortashasi' bul sanlardi'n' yen' kishisinen u'lken ha'm yen' u'lkeninen kishi boladi'. Buni'n' duri'sli'g'i'n joqari'dagi' 1-mi'salda tekserip ko'rin'.

Wortasha tezlik dep bas'p wo'tilgen joldi'n' sari'plag'n waqi'tqa qatnasi'na ayti'ladi'.

2- mi'sal. Poezd 2 saat 85 km/saat tezlik penen ha'm 3 saat 80 km/saat 3 soat tezlik penen ju'rdi. Poezdi'n' wo'rtasha tezligin tabi'n'.

Sheshiliwi: Poezd basi'p wo'tken joldi' yesaplaymi'z:

$$85 \cdot 2 + 80 \cdot 3 = 170 + 240 = 410 \text{ (km)}.$$

Bul arali'qti' sari'plang'an waqi't $2 + 3 = 5$. Poezdi'n' wo'rtasha tezligin tabi'w ushi'n basi'p wo'tken joldi' sari'plang'an waqi'tqa bo'lemiz: $410 : 5 = 82 \text{ (km/saat)}$.

Juwabi': Poezdi'n' wo'rtasha tezligi – 82 km/saat.

Bul na'tiyjeni poezdi'n' ha'rbir saattagi' tezliklerini'n' aridmetikal'q wortashasi'n yesaplaw arqali' da tabi'wg'a boladi': $(85 + 85 + 80 + 80 + 80) : 5 = 82 \text{ (km/saat)}$.

Sorawlarg'a juwap berin'!



1. Bir neshe sanlardi'n' arifmetikal'q wortashasi' dep nege ayti'ladi'?
2. Wortasha tezlik qalay tabi'ladi'?



Klasta wori'nlanatug'i'n shi'ni'g'i'wlar



- 1031.** Sanlardi'n' arifmetikali'q wortashasi'n yesaplan':
 a) 2,18; 8,03; b) 0,49; 2,82; 6,41; d) 16,03; 8,41; 3,07; 0,1;
- 1032.** Poezdti'n' birinshi saatta 55 km, yekinshi saatta 75 km ju'rdi. Poezdi'n' usi' yeki saattag'i' wortasha tezlugin tabi'n'.
- 1033.** Sayaxatshi' 4 saat 2,7 m/sekund tezlik penen, son' bolsa 5 saat 1,8 m/sekund tezlik penen ju'rdi. Sayaxatshi'ni'n' wortasha tezligi qansha?
- 1034.** a) 8 ha'm 10; b) 12 ha'm 16; d) 4 ha'm 8 sanlari'ni'n' arifmetikali'q wortashasi'n tabi'n'. Bul sanlardi' ha'm wolardi'n' arifmetikali'q wortashasi'n sanlar nuri'nda ko'rsetin'. Ne sebepten "sanlardi'n' arifmetikali'q wortasha" atamasi'nda "wortasha" so'zini'n' qo'llani'li'wi' haqqi'nda woylap ko'rin'.
- 1035.** Cexta 3 jumi'sshi' isleydi. Bir saatta birinshi jumi'sshi' 24, yekinshi jumi'sshi' 20, u'shinshi jumi'sshi' bolsa 27 detalg'a islew beredi. Cex jumi'sshi'lari' miynetinin' wortasha wo'nimdarli'g'i' qansha?
- 1036.** "Nasaf" tez ju'rer poezdi Tashkentten Samarqandqa shekem 3,2 saat 95 km/saat tezlik penen, Samarqandtan Qarshi'g'a shekem bolsa 2,1 saat 90 km/saat tezlik penen ju'rdi. "Nasaf" poezdi'ni'n' wortasha tezligin ani'qlan'.



- 1037. Sanlardi'n' arifmetikali'q wortashasi'n tabi'n':**
 a) 80,6; 71,3; || b) 0,4; 0,8; 0,9; || d) 2,11; 2,12; 2,19; 2,48;
- 1038.** *a* ha'm 8,9 sanlari'ni'n' arifmetikali'q wortashasi' – 9,5 ke ten'. *a* sani'n tabi'n.
- 1039.** *Ameliy jumi's*. Ta'rezide 100 g ma'sh wo'lshep ali'n'. Wondag'i' ma'sh da'neshelerin sani'n sanan'. Bir dana ma'shtin' wortasha massasi'n tabi'n'.
- 1040.** Konkide figurali' ushi'w boyi'nsha qatnasqan Sa'hibjamal 5,3; 4,8; 5,4; 5,0; 5,3; 5,4; 5,3; 5,2; 5,1 bahalar aldi'. Sa'hibjamal alg'an wortasha bahani' tabi'n.
- 1041.** Bir ha'pte dawami'nda hawa basi'mi' to'mendegishe boldi': 18⁰C; 20⁰C; 21⁰C; 18⁰C; 19⁰C; 22⁰C; 24⁰C. Bul ha'pte dawami'nda wortasha basi'm qanshani' qurag'an?
- 1042.** 114,12; 14,747; 14,96 ha'm 14,58 sanlari'ni'n' arifmetikali'q wortashasi'n tabi'n' ha'm woni' wonnan birge shekem do'n'geleklen'.



- 1043.** Xojali'q bes ji'l dawami'nda ha'r ji'lda wortasha 76,3 t qant la'blebi jetistirgen. Usi' bes ji'l dawami'nda xojali'qta barli'g'i' boli'p neshe tonna qant la'blebisi jetistirilgen?
- 1044.** Samalyot Tashkentten Andijang'a 45 minut 800 km/saat tezlik penen, Andijannan Tashkentke bolsa 1 saat 15 minut 750 km/saat tezlik penen ushti'. Samalyotti'n' wortasha tezligin tabi'n'.
- 1045.** Bir tamshi' suwdi'n' massasi'n ani'qlaw ushi'n stakang'a 100 tamshi' suw tami'zi'ladi' ha'm woni'n' massasi' ta'rezide tarti'li'p 62 g yekenligi ani'qlanadi'. Yeger bos stakanni'n' massasi' 55 g bolsa, bir tamshi' suwdi'n' massasi' qansha?



- 1046.** Termometr menen hawa basi'mi' sutka dawami'nda wo'lshengende azanda $+18^{\circ}\text{C}$, tu'ste $+25^{\circ}\text{C}$, keshquri'n $+21^{\circ}\text{C}$ ha'm tu'nde $+10^{\circ}\text{C}$ ti' ko'rsetdi. Sutkali'q wortasha temperaturani' ani'qlan'.
- 1047.** Xa'disha sherek dawami'nda matematikadan to'mendegi bahalardi' aldi': 5, 5, 4, 5, 4, 5, 5, 4. Woni'n' sherek boyinsha wortasha bahasi'n tabi'n' ha'm woni' qandayda bir tan'basina shekem do'n'geleklen'.

U'yde wori'nlanatug'i'n ma'seleler



- 1048.** Sanlardi'n' arifmetikali'q wortashasi'n yesaplan':
 a) 4,38; 6,05. b) 0,39; 9,42; 3,41. d) 6,07; 12,41; 2,011.
 e) 1,02; 1,15; 1,3; 1,4. f) 22,4; 36,7; 56,2. g) 0,203; 0,324; 2,61.
- 1049.** Won adi'mi'n'i'zdi'n' uzi'nli'g'i'n wo'lshen' ha'm adi'mi'n'i'zdi'n' wortasha uzi'nli'g'i'n tabi'n'.
- 1050.** Poezd birinshi saatta 76 km, yekinshi saatta 90 km, u'shinshi saatta bolsa 80 km ju'rdi. Poezdi'n' usi' u'sh saattag'i' wortasha tezligi qansha?



- 1051.** Poezd birinshi saatta 76 km, yekinshi saatta 90 km, u'shinshi saatta bolsa 80 km ju'rdi. Poezdi'n' usi' u'sh saattag'i' wortasha tezligi qansha?
- 1052.** Yeki sannin' arifmetikali'q ortashasi' 5,4. yekinshi san 7,8 bolsa, birinshi sandi' tabi'n'.
- 1053.** Yeki sannin' arifmetikali'q ortashasi' 6,2. Birinshi san yekinshi sannan 1,5 ma'rte u'lken bolsa, bul sanlardi' tabi'n'.
- 1054.** A'mellerdi wori'nlan':
 $((4 : 0,128 + 14628,25) : 1,011 - 0,00008 + 6,84) : 12,5$.



- 1055.** Avtomobil u'lken ko'sheden 2,1 saat 90 km/saat tezlik penen, son' bolsa 3,8 saat tas ko'sheden 40 km/saat tezlik penen ju'rdi. Avtomobildin' wortasha tezligin tabi'n'.
- 1056.** To'rt sannin' arifmetikali'q wortashasi' 8,9 g'a ten'. Basqa 6 sannin' arifmetikali'q wortashasi' bolsa 13,8 ge ten'. Bul won sannin' arifmetikali'q wortashasi' qansha?
- 1057.** To'mendegi su'wrette a'yyemgi zamanlarda jasag'an dinozavr klasi'na tiyisli bolg'an stegozavrus ha'm adam su'wretlengen. Su'wrettegi mag'li'wmatlardan paydalani'p, stegozavrusdi'n' wo'lshemlerin ani'qlan' ha'm woni'n' uzi'nli'g'i' adamnan shama menen neshe ma'rte u'lken yekenligin tabi'n'.

No	Ati'	Sani' (dana)	Ja'mi quwati', (kilovatt)	Sutkada isletiliwi (saat)	Sutkada sari'plangan elektr energiyasi (kilovatt·saat)
1.	Elektr lampochkasi'	6	0,36	14	
2.	Muzlatqi'sh	1	0,03	24	
3.	Televizor	1	0,085	2	
4.	Kompyuter	1	0,25	3	
5.	Utyog	1	2,3	0,1	
				Jami	

45.1. Shan'araqta u'nemlilik ha'm matematika

Elektr lampasi' jang'anda ya'ki elektr a'sbaplari' isletilgunde elektr energiyasi' sari'planadi'. Elektr energiyasi' elektr stansiylari'nda islep shi'g'ari'ladi'. Woni' islep shi'g'ari'wda suw, gaz ha'm neft wo'nimlirinen paydalani'ladi'.



Elektr energiyasi'nan u'nemli paydalani'w kerek.

Elektr energiyasi' kilovatt-saat dep atalg'an wo'lshem birliginde wo'lshenedi. Sari'plang'an 1 kilovatt-saat elektr energiyasi' ushi'n xali'q 144,3 swm to'leydi (2014- ji'l oktyabr ayi'nda).

Shan'araqta sari'plang'an elektr energiyasi' arnawli' yesaplag'i'sh ja'rdemide wo'lshep bari'ladi'. Shan'araq iyesi yesaplag'i'sh ko'rsetkishine qarap ha'r ayda to'lemdi a'melge asi'radi'. Aytayi'q, sentyabr ayi' basi'nda yesaplag'i'sh 34 538 di, ay aqi'ri'nda 34 658 di ko'rsetken bolsi'n. Demek, sentyabr ayi'nda shan'araq $34\ 658 - 34\ 538 = 120$ (kilovatt-saat) elektr energiyasi'n sai'plag'an. 1 kilovatt-saat elektr energiyasi' 76,8 swm turi'wi'n yesapqa alsaq, $120 \cdot 144,3 = 17\ 316$ (swm) to'lewi lazi'm boladi'.

1058. Utyog 1 saat isletilgunde 1 kilovatt-saat elektr energiyasi' sari'planadi'.

Utyog a) 3 saat; b) 4 saat isletilgunde neshe swmli'q elektr energiyasi' sari'planadi'?

1059. Elektr lampasi' 10 saat jani'p tursa, 1 kilovatt-saat elektr energiyasi' sari'planadi'. Keshte jolaqsha 10 saat dawami'nda jaqti' boladi'. Bir ay (30 ku'n) dawami'nda jolaqshani' jari'ti'w ushi'n ma'mleket ta'repinen qansha qarji' sari'planadi'?

1060. Shan'araqta bir ay dawami'nda 50 saat kereksiz jani'p qalg'an a) bir; b) yeki; d) u'sh elektr lampasi' ushi'n neshe swm to'lewi kerek boladi'?

1061. Su'wrette su'wretlengen yesaplag'i'shti'n' da'slepki (a-su'wret) ha'm aqi'rg'i' (b-su'wret) ko'rsetkishlerine qarap, sari'plang'an elektr energiyasi' ushi'n qansha pul to'lewi lazi'mli'g'i'n ani'qlan':

a)



b)



1062. I'ssi' suw yesaplag'i'shi'ni'n' (kub metrde) da'stlebki – 546 091 ha'm aqi'rg'i' – 546 121 ko'rsetkishlerine qarap sari'plang'an i'ssi' suw ushi'n qansha pul to'lew lazi'mli'g'i'n ani'qlan'. Sari'plang'an 1 kub metr i'ssi' suw bahasi' 2706,76 swmdi' quraydi' (2014-ji'l oktabr ayi'nda).



1063. Su'wrette su'wretlengen gaz yesaplag'i'shti'n' (kub metrde) da'slepki (a-su'wret) ha'm aqi'rg'i' (b-su'wret) ko'rsetkishlerine qarap, sari'plang'an gaz ushi'n qansha pul to'lewi lazi'mli'g'i'n ani'qlan'. Sari'plang'an 1 kub metr gaz bahasi' 181,62 swmdi' quraydi' (2014-ji'l oktabr ayi'nda):



1064. Suwi'q suw yesaplag'i'shi'ni'n' (kub metrde) da'stlebki – 120 674 ha'm aqi'rg'i' – 120 723 ko'rsetkishlerine qarap sari'plang'an suwi'q suw ushi'n qansha pul to'lew kerekligin ani'qlan'. Sari'plang'an 1 kub metr suwi'q suw bahasi' 310 swmdi' quyaydi' (2014-ji'l oktabr ayi'nda).

1065. Ekonomistlerdin' yesap-kitaplari'na qarag'anda suwdi'n' qulag'i' jaqsi' qaytari'lmasa, wonnan 1 sutkada 140 litr suw tamshi'lap ag'i'p ketedi yeken. Bir ay (30 ku'n) da bul sazlanbag'an suwdi'n' qulag'inan qansha suw ag'i'p zaya boladi'? Zaya bolg'an suwg'a qansha haqi' to'lew kerek boladi'?



Suw – tirishilik deregi'! Woni' u'nemlep qollani'n'!

45.2. VII bapqa tiyisli ma'selelerdi sheshiw

- 1066.** An'shi'lardan biri 30 qoyan atti'. Yekinshisi birinshisinen 0,4 ma'rte ko'p, u'shinshisi bolsa yekinshisinen 10 kem qoyan atti'. U'sh an'shi' qansha qoyan atqan?
- 1067.** Birinshi ati'z maydani' 189,5 ga, yekinshisinin' maydani' wonnan 15 ga arti'q. Birinshi ati'zdi'n' gektari'nan 24 c, yekinshisinin' gektari'nan 31 c biyday ali'ng'an bolsa, yeki ati'zdan qansha biyday wo'nimi ali'ng'an?
- 1068.** Men bir san woyladi'm. Yeger bul sang'a woni'n' wo'zin qosi'p, 2,8 ge ko'beytirilse, 95,2 payda boladi'. Men woylag'an sandi' tabi'n'.
- 1069.** Mektep asxanasi'ni'n' uzi'nli'g'i' 29,8 m, yeni bolsa 15 m. Mektep asxanasi'ni'n' maydani'n tabi'n'. Juwapti' ju'zden birgeshe do'ngeleken'.
- 1070.** Bo'lmenin' uzi'nli'g'i' 5,5 m, yeni bolsa bo'lmenin' uzi'nli'g'i'nan yeki ma'rte uzi'n. Yeger bo'lmenin' biyikligi 3,5 m bolsa, woni'n' ko'lemin tabi'n'.
- 1071.** Du'kan u'sh ku'nde 1289,7 kg un satti'. Birinshi ku'ni 321,3 kg, yekinshi ku'ni u'shinshi ku'nine qarag'anda 3 ma'rte ko'p un sati'ldi'. U'shinshi ku'ni neshe kilogramm un sati'lg'an?
- 1072.** Kater ag'i'mg'a qarsi' ha'reket qi'li'p, 4 saatta 143,5 km jol basti'. Yeger ag'i'mni'n' tezligi 3,2 km/saat bolsa, katerdin' wo'zi'nin' tezligin tabi'n'.

- 1073.** Yeger $x = 1; 10; 3; 100; 1000; 10\ 000$ bolsa, $53,6x$ an'latpani'n' ma'nisin tabi'n'.
- 1074.** Yeger: a) $a = 6,328, b = 63$; b) $a = 0,532, b = 52$ bolsa, $a \cdot 100 + 9$ an'latpani'n' ma'nisin tabi'n'.
- 1075.** Yeger 15 birdey denenin' massasi' 21,8 kg yekendligi belgili bolsa, 28 sonday denenin' massasi'n tabi'n'.
- 1076.** Yeki quti'da 16,8 kg shay bar. yeger birinshi quti'dan yekinshisine 0,9 kg shay ali'p sali'nsa, yeki quti'dag'i' shay ten' boladi'. Ha'rbir quti'da qansha shay bar?
- 1077.** 74,3 m tawar yeki bo'lekke bo'lindi. Birinshi bo'lekte yekinshisine qarag'anda 2,6 m ko'p tawar bar. Ha'rbir bo'lekte neshe metr tawar bar?
- 1078.** Yeki yashikte ten' mug'darda pomidor bar. Yeger birinchi yashikten 4,5 kg pomidor ali'nsa, yekinshisinde 2 ma'рте ko'p pomidor boladi'. Yeki yashikte qansha pomidor bar?
- 1079.** 1 litr su'tten 200 gramm qaymaq ali'nadi'. 1 kg qaymaq ali'w ushi'n neshe litr su't kerek boladi'?
- 1080.** Quti'g'a ha'r birinin' massasi' m g bolg'an n dana banka sali'ng'an bolsa, woni'n' massasi' $M = m \cdot n$ formula arqali' an'latiladi'. Bul formuladan paydalani'p, to'mendegi kesteni toltiri'n':

M		6 kg	3000 g	8,4g		9,6 kg
m	0,25 kg		150 g		480 g	0,8 kg
n	12	6		24	10	

- 1081.** Pal ha'rresi 200 g pal jiynaw ushi'n 2 mln gu'lge qonadi'. Pal ha'rre bir gu'lden qansha gramm pal aladi'?
- 1082.** Aynani'n' uzi'nli'g'i' 6,32 m, yeni 3,09 m. Aynani'n' maydani' nege ten'? Juwapti' wonnan birge shekem do'n'geleklen'.
- 1083.** 1 kg gu'rish 2800 swm turadi', a) 2,3 kg, b) 1,5 kg, d) 0,8 kg, e) 0,2 kg gu'rish qansha turadi'?
- 1084.** Mashina 37,5 km/saat tezlik penen 9,2 saatta neshe kilometr ju'redi? 2,23 saatta ne?
- 1085.** 1 sm^3 alti'nni'n' massasi' 6,72 g. Ko'lemi 5,2 sm^3 bolg'an alti'n bo'leginin' massasi'n tabi'n'.
- 1086.** Yeger tuwri'mu'yeshlktin' wo'lshemleri: a) 7,1 sm; 5,2 sm; b) 0,83 sm; 1,34 sm bolsa, woni'n' maydani'n tabi'n'.
- 1087.** 1,8 kg qa'reli ha'm 2,3 kg yerik sati'p ali'ndi'. 1 kg qa'reli 3,5 mi'n' swm turadi'. Yeriktin' bahasi' qa'reli bahasi'nan 1,4 mi'n' swm qi'mbat. Sati'p ali'w ushi'n ja'mi qansha pul to'lengen?
- 1088.** Birinshi bag'da 163 tu'p terek bar, yekinshi bag'da bolsa wonnan 35 tu'p ko'p terek bar. Ha'r bir terekten wortasha 6,8 kg nan payda ali'nsa, yeki bag'dan ja'mi qansha payda ali'nadi'?



- 1089.** Kompyuter monitori' diagonali'ni'n' wo'lshemleri a) 17; b) 19; d) 21 dyuym. Yeger 1 dyuym 2,54 sm ge ten' bolsa, monitor wo'lshemin santimetrlerde an'lati'n'.
- 1090.** 2010-ji'li AQSH ta jarati'lg'an "Terrafugia" ushar avtomobili 270 km arali'qti' usha aladi'. Bul aeromobil hawada 185 km/saat tezlikte neshe saat usha aladi'?
- 1091.** Uzaq arali'qqa juwi'ri'w – marafon arali'g'i' 42 km 195 m di quraydi'. Bul arali'qti' dunyada yen' tez basi'p wo'tken insan – leffiopiyali'q sporshi' Xayle Gebreselassi yesaplanadi'. Wol bul arali'qti' 2 saat 3 minut 59 sekundta basi'p wo'tken. Xayle bul arali'qti' wortasha qanday tezlikte basi'p wo'tken?
- 1092.** Abdurahmanda 4500 swm, Ashrafta 1700 swm, Mahmudta bolsa 2800 swm pul bar. Wolar pullari'n qosi'p, kinog'a 3 bilet aldi'. Bir bilet bahasi' qansha?

Bilimin'izdi si'nap ko'rin'!



Bul bap materiallari'n u'yrenip shi'g'i'p, to'mendegi ma'selelerdi sheshe ali'wi'n'i'z sha'rt! Qadag'alaw jumi'si' aldi'nan wo'zin'izdi si'nap ko'rin'!

Test. Duri's juwapti' ani'qlan'.

- Wonli'q bo'lshekti 0,001 bo'liw ushi'n wonli'q bo'lshekтеgi u'tirdi qayerge ji'lji'ti'w jeterli??

A. Shepke 2 tan'ba;		B. Shepke 3 tan'ba;
D. Won'g'a 3 tan'ba;		E. Won'g'a 3 tan'ba.
- Bo'lshek sandi' 0,01 ge bo'liw qanday sang'a ko'beytiw degeni?

A. 100;		B. 10;		D. 1000;		E. 0,01.
---------	--	--------	--	----------	--	----------
- $0,2209 \cdot 412,038$ ko'beymede u'tirden keyin neshe cifr boladi?

A. 4 ta;		B. 6 ta;		D. 7 ta;		E. 3 ta.
----------	--	----------	--	----------	--	----------

11-qadag'alaw jumi's u'lgisi

- Yesaplan':

a) $0,872 \cdot 6,3$;		b) $1,6 \cdot 7,625$;		d) $0,045 \cdot 0,1$;
e) $30,42 : 7,8$;		f) $0,702 : 0,065$;		g) $0,026 : 0,01$.
- Sanlardi'n' arifmetikali'q wortashasi'n tabi'n':
32,4; 41; 27,95; 46,9; 55,75.
- An'latpani'n' ma'nisin tabi'n': $296,2 - 2,7 \cdot 6,6 + 6 : 0,15$.
- Poezd 63,2 km/saat tezlik penen 3 saat, 76,5 km/saat tezlik penen 4 saat ju'rди. Poezddin' pu'tin joldag'i' wortasha tezligin tabi'n'.
- U'sh sanni'n' qosi'ndi'si' 10,23 ke ten'. 6 basqa sanlardi'n' arifmetikali'q wortashasi' 2,9 g'a ten'. Ba'rshe 9 sanni'n' arifmetikali'q wortashasi'n tabi'n'.



VIII BAP. PROCENTLER

46- §.

PROCENT HAQQI'NDA TU'SINIK

A'yyemnen turmi'sta ko'p qollani'latug'i'n u'lesler arawli' atlar menen atalg'an. Ma'selen, yekiden birin – yari'm, to'rten birin – sherek, segizden birin – yari'm sherek dep atali'wi'n bilemiz. Ju'zden bir de arawli' at penen ju'ritiledi ha'm wol *procent* dep ataladi'.

“Procent” so'zi radio ha'm televideniye xabarlarini' arqali' tez-tez qulag'i'n'i'zg'a shali'ng'an bolsa kerek. Ma'selen, saylawg'a saylawshi'lardi'n' 93 procenti qatnasti', ayli'q 20 procentke asi'ri'ldi', qala transportta ju'riw bileti 10 procentke asi'ri'ldi'.

Shamani'n' (sanni'n') ju'zden bir u'lesi woni'n' *bir procenti* dep ataladi'.

Ma'selen, 400 km din' 1 procenti – 4 km, sebebi 400 din' ju'zden bir u'lesi: $400 : 100 = 4$.

1 kg ni'n' 1 procenti – 10 g, sebebi 1 kg = 1000 g ha'm 1000 din' ju'zden bir u'lesi: $1000 : 100 = 10$.

350 din' 1 procenti – 3,5, sebebi 350 din' ju'zden bir u'lesi: $350 : 100 = 3,5$.

Geyde “procent” so'zi worni'na qolayli' boli'w ushi'n «%» belgisi isletiledi.



1 procent – sanni'n' (shamani'n') ju'zden bir u'lesi bolg'ani' ushi'n, bul sanni'n' (shamani'n') wo'zi – 100 procent ke ten' boladi'.

Solay yetip,

$$1\% = \frac{1}{100} = 0,01$$

$$100\% = 1$$

1- mi'sal. Asaka avtomobil zavodi' bir ha'ptede 840 avtomobil islep shi'g'ardi'. Wolardi'n' 20 prosentini' “Spark” avtomobili. Zavod bir ha'ptede neshe “Spark” avtomobilin islep shi'g'arg'an?

Sheshiliwi: 840 avtomobildi 100 % desek, woni'n' 1 procenti, yag'ni'y ju'zden bir u'lesi:

$$840 : 100 = 8,4.$$



Avtomobillerdin' 20 procentin tabi'w ushi'n 8,4 ti 20 g'a ko'beytemiz: $8,4 \cdot 20 = 168$.

Juwabi': Asaka zavodi' bir ha'ptede 168 "Spark" avtomobilin islep shi'g'aradi'.



2- mi'sal. Nanbayxanada jabi'lg'an 1800 nanni'n' 75 procenti azanda sati'ldi'. Azanda neshe nan sati'lg'an?

Sheshiliwi: 1800 nanni'n' 1 procenti: $1800 : 100 = 18$ (nan) boladi'. Barli'q nanni'n' 75 procentin tabi'w ushi'n 18 di 75 ke ko'beytemiz: $18 \cdot 75 = 1350$ (ta non).

Juwabi': Azanda 1350 nan sati'lg'an.

Sandi' procentke aylandi'ri'w ushi'n woni' 100 ge ko'beytiw jetkilikli.

Procentti sang'a aylandi'ri'w ushi'n bolsa woni' 100 ge bo'liw jetkilikli.



Ma'selen, a) $0,832 = 0,832 \cdot 100\% = 83,2\%$; b) $1,78 = 1,78 \cdot 100\% = 178\%$;
d) $56\% = 56 : 100 = 0,56$; e) $239\% = 239 : 100 = 2,39$.

Geyde procentlerdi sang'a aylandi'ri'pta islep ko'riwge de tuwri' keledi. Ma'selen, bir shamani'n' 45 % tabi'w ushi'n bul shamani'n' $\frac{45}{100}$ bo'legin tabi'w, yag'ni'y woni' 0,45 ke ko'beytiw jetkilikli.

Shamani'n' (sanni'n') p procentin tabi'w woni'n' $\frac{p}{100}$ bo'legin tabi'w deg.

Sorawlarg'a juwap berin'!



1. Procent dep nege ayti'ladi'?
2. Shamani'n' ju'zden bir u'lesi - 1% bolsa, shamani'n' wo'zi neshe procent boladi'?
3. Sanni'n' procenti qalay tabi'ladi'?
4. Wonli'q bo'lshekti procentke aylandi'ri'w ushi'n ne islew kerek?
5. Procentti wonli'q bo'lshekke aylandi'ri'w ushi'n ne islew kerek?

Klasta wori'nlanatug'i'n shi'ni'g'i'wlar



1093. Kvadrat maydani'ni'n' neshe procenti boyalg'an?

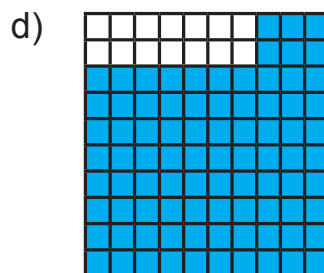
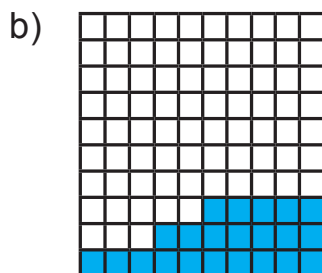
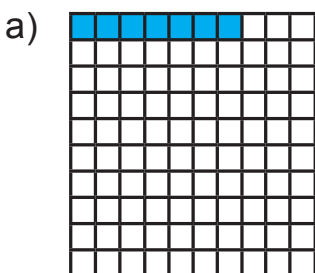

1094. Procentlerde an'lati'n':

- a) saylawshi'lardi'n $\frac{97}{100}$ bo'legi; b) qala xalqi'ni'n' $\frac{68}{100}$ bo'legi;
d) kitapxanadag'i' kitaplardi'n' 0,12 bo'legi; e) hosilning 0,26 bo'legi.

1095. To'mendegilerdi procent so'zin qosi'p qayta ayti'n':

- a) Ha'r 100 na'restenin' 52 si yer balalar;
b) Ha'r 100 woqi'wshi'ni'n' 74 ti do'gereklerge qatnasadi';
d) Ha'r 100 avtomobildin' 75 ti yelimizde islep shi'g'i'ladi';
e) Ha'r 100 adamni'n' 8 inde qol telefoni' bar.

1096. Shamani'n' 1 procentin tabi'n':

- a) 200 m; || b) 2500 swm; || d) 400 km; || e) 1500 kg; || f) 3800 t; || g) 10 000 mm.

1097. Awi'lda 12000 xali'q jasadidi'. Awi'l xalqi'ni'n':

- a) 1; b) 5; d) 12; e) 20; f) 50; g) 75; h) 95 foizi necha kishini tashkil qiladi?

1098. a) 1%; b) 5%; d) 12%; e) 25%; f) 100% procentin tabi'n';

1099. O'zbekistan Respublikasi'ni'n' jer maydani' qurg'aqli'qti'n' 0,3 procentin quraydi'. Yeger Jer betindegi qurg'aqli'qti'n' maydani' 149,633 million km kvadrat bolsa ma'mleketimizdin' jer maydani'n tabi'n'.



1100. Jumi'sshi' 220 000 swm si'yli'q aldi'. Wol si'yli'qti'n' ju'zden bir bo'legine balasi' ushi'n sawg'a aldi'. Sawg'a qansha turadi'?

1101. Du'kang'a 850 kg qi'yar ali'p kelindi. Birinshi qari'ydard barli'q qi'yardi'n' 1 procentin, yekinhisi barli'q qi'yardi'n' 3 procentin sati'p aldi'. Ha'r bir qari'ydard neshe kg qi'yar sati'p alg'an?

1102. Du'kandag'i' 700 kg almani'n' 30 procenti sati'ldi'. Neshe kg alma sati'lg'an? Du'kanda neshe procent alma qalg'an?

1103. Maydani' 620 ga bolg'an ati'zg'a paxta teriw mashinalari' shi'g'ari'ldi'. Wolar bir ku'nde ati'zdi'n' 35 procentindegi paxtani' terdi. Bir ku'nde neshe gektardag'i' paxta terilgen?

1104. Jumi'sshi'larg'a 760 m uzi'nli'qtag'i' joldi' qayta islew tapsi'ri'ldi'. Yeger wolar tapsi'rmani'n' a) 30; b) 50; d) 100 procentin wori'nlag'an bolsa, neshe metr jer qayta islengen?



U'yde wori'nlanatug'i'n shi'ni'g'i'wlar

1105. Shamani'n' 1 procentin tabi'n':

- a) 600 m; || b) 6500 swm; || d) 8354 t; || e) 68 m; || f) 15 s; || g) 650 000 mm.

1106. Qalada 220 00 xalq jasadidi'. Qala xalqi'ni'n': a) 1%; b) 8%; d) 182%; e) 25%; f) 60%; g) 75%; procenti neshe adamdi' quraydi'?

1107. Jer ju'zinin' xalqi' 2015- ji'l yanvar ayi'na kelip 7 262 820 500 adamg'a jetti. O'zbestanda Jer ju'zi xalqi'ni'n' shama menen 0,4216 procenti jasadidi'. O'zbekstan xalqi' bul waqi'tta shama menen neshe procentti quraydi'?



1108. Student 120 000 swm stipendiya aldi'. Wol bul stependiyani'n' 2 procentine woqi'w qurallari'n sati'p aldi'. Student sati'p alg'an woqi'w qurallar qansha turadi'?

1109. A'mellerdi wori'nlan':

- a) $40,27 \cdot (6,38 + 7,62) - (47,45 + 9,25) : 21$;
 b) $21,38 \cdot (324,6 - 224,6) + 2643,3 - 2643,3 : 33$;
 d) $10,12 - 8,12 : (6,38 - 2,38)$.

Shan'araqta u'nemlilik ha'm matematika



1110. To'mendegi kestede shan'araqti'n' 5 ku'n dawami'nda quwati'n sari'plaw ko'rsetkishleri keltirilgen. Bul mag'li'wmatlardan paydalani'p kestenin' bos keteklerin toltiri'n' (1 kilovatt-saat elektr energiya bahasi' 144,3 swm). Sog'an uqsas kesteni wo'z shan'arag'i'n'i'n' mi'sali'nda da du'zin' ha'm juwmaq shi'g'ari'n'.

Sa'ne	Yesaplag'i'sh ko'rsetkishi (kilovatt-saat)	Elektr energiyasi' sari'pi' (kilovatt-saat)	Elektr energiyasi ushi'n to'lew (swm)
14.01.2015 ji'l.	8774	9	
15.01.2015 ji'l.	8779	5	
16.01.2015 ji'l.	8785	6	
17.01.2015 ji'l.	8793	8	
18.01.2015 ji'l.	8801	8	
O'rtacha bir kunda			
O'rtacha bir oyda			
O'rtacha bir yilda			

Matematika tari'ysi'na tiyisli u'zindiler



"%"–procent belgisi XVII a'sirden baslap isletile baslang'an. 1685-ji'li' francuz matematigi Mate de la Portti'n' "Tijarat arifmetikasi' boyi'nsha qollanba" kitabi' baspadan shi'qti'. Wonda procentler haqqi'nda da so'z yetken. Sol waqi'tlarda procent – "Cento" (ju'zden) so'zinin' qi'sqarti'lg'an u'sh ha'ribi "cto" menen belgilener yedi. Biraq, baspaxanada ha'rip teriwshi adasi'p "cto" worni'na "%" ti basi'p jibergen. Sol ta'rizde matematikada biz ha'zir de paydalani'p ati'rg'an "%" procent belgisi kirip kelgen.

Qiziqarli matematikaga oid masalalar



- San aldi'n 10 procentke artti'ri'lg'an. Son' ja'ne 10 procent ke artti'ri'lg'an. Da'slepki san neshe procentke artadi'?
- San aldi'n 10 procentke kemeytirildi. Son' ja'ne 10 procentke kemeytirildi. Da'slepki san neshe prosentke kemeytirildi?
- San aldi'n 10 procentke artti'ri'ldi'. Son' 10 procentke kemeytirildi. Na'-tijede da'slepki san artti'ma yamasa kemeydime? Neshe procentke?

47- §.

PROCENTKE TIYISLI MA'SELELER SHESHIW

1- *mi'sal.* Abdurahman kitapti'n' 36 betin woqi'p shi'qti'. Bul kitapti'n' 18 procenti quraydi'. Kitap neshe betten ibarat?

Sheshiliwi: Sha'rt boyi'nsha kitapti'n' 18 procenti – 36 bet. Wonda kitapti'n' 1 procenti: $36 : 18 = 2$ betin quraydi'. Yendi, kitapti'n' barli'q betlerinin' sani'n yag'ni'y 100 procentin tabami'z. Buni'n' ushi'n 2 ni 100 ge ko'beytemiz: $2 \cdot 100 = 200$ (bet).

Juwabi: Kitap 200 betten ibarat.

2- *mi'sal.* Saylawda 11 570 adam qatnasi'p, bul pu'tin ucastka saylawshi'lari'ni'n' 89 procentin quraydi'. Saylaw ucastkasi'nda qansha saylawshi' bar?

Sheshiliwi: Sha'rt boyi'nsha saylawshi'lardi'n' 89 % – 11 570 adam. Wonda saylawshi'lardi'n' 1 %: $11\ 570 : 89 = 130$ adamdi' quraydi'.

Barli'q saylawshi'lar sani'n tabi'w ushi'n 130 di' 100 ge ko'beytemiz:

$$130 \cdot 100 = 13\ 000 \text{ (adam).}$$

Juwabi: Saylaw ucastkasi'nda 13 000 saylawshi' bar.

3- *mi'sal.* 300 gektarli'q ati'zdi'n' 225 gektari' su'rildi. Ati'zdi'n' neshe procenti su'rilgen?

Sheshiliwi: Sha'rt boyi'nsha ati'zdi'n' $\frac{225}{300}$ bo'legi su'rilgen. Bul bo'lshekti wonli'q ko'rinishinde an'latami'z. Buni'n' ushi'n 225 ti 300 ge bo'lemiz. Na'tiyjede, 0,75 ti payda yetemiz.

Juwabi: Ati'zdi'n' 75 procenti aydalg'an.

4- *mi'sal.* Stadion 50 000 adamg'a mo'lshe'rlengen. Na'wbettegi futbol woyi'ni'n' 32 500 tamashago'y tamasha qi'ldi'. Bul woyi'nda stadiioni'n' neshe procent wori'nli'qlari' ba'nt bolg'an?

Sheshiliwi: 32 500 di 50 000 g'a bo'lemiz ha'm tiyindini procentlerde an'latami'z:

$$\frac{32\ 500}{50\ 000} = 0,65; \quad 0,65 = 0,65 \cdot 100\% = 65\%.$$

Juwabi: Stadiioni'n' 65 % wori'nli'qlari' ba'nt bolg'an.

5- *mi'sal.* Abdullaev bankke 50 000 swm pul qoydi'. Bank Abdullaevqa bul puldi' 1 ji'lda 25 procentke ko'beytip qaytaratug'i'n boldi'. Bir ji'lda Abdullaevti'n' puli' qanshag'a ko'beyedi? Wol banktan 1 ji'ldan keyin qansha pul qaytari'p aladi'?

Sheshiliwi: Amanatti'n' 1 procenti: $50\ 000 : 100 = 500$ (swm);

25 procenti: $500 \cdot 25 = 12\ 500$ (swm) boladi'.

Demek, Abdullaevti'n' amanati' 1 ji'lda 12 500 swmg'a ko'beyip, wol ji'l aqi'ri'nda banktan $50\ 000 + 12\ 500 = 62\ 500$ swm qaytari'p aldi'.

Juwabi: 12 500 swm, 62 500 swm.



6- mi'sal. Du'kandag'i 30 000 swmli'q ko'ylek bahasi' 15 procentke arzanlasti'ri'ldi'. Ko'ylek bahasi' qanshag'a arzanlasti'? Ko'ylektin' jan'a bahasi' neshe swmdi' quraydi'?

Sheshiliwi: Ko'ylek bahasi'ni'n' 1 procenti: $30\ 000 : 100 = 300$ (swm);
15 procenti: $300 \cdot 15 = 4\ 500$ (swm) boladi'.

Demek, ko'ylek bahasi' 4 500 swmg'a arzanlasi'p, jan'a bahasi' $30\ 000 - 4500 = 25\ 500$ swmdi' quraydi'.

Juwabi: 4 500 swm, 25 500 swm.

7- mi'sal. Bazarda go'sh bahasi' – 15 000 boli'p, wol 10 procentke qi'mbatlasti'. Go'shtin' jan'a bahasi' qansha boldi'?

Sheshiliwi: Go'sh bahasi' 1 procenti: $25\ 000 : 100 = 250$ (swm);
10 procenti: $250 \cdot 10 = 2500$ (swm) bo'ladi.

Demek, bazarda go'sh bahasi' 2 500 swmg'a qi'mbatlasi'p, jan'a bahasi' $25\ 000 + 2500 = 27\ 500$ swmdi' quraydi'.

Juwabi: 27 500 swm.

Sorawlarg'a juwap berin!



1. Sanni'n' procentine qarap wo'zi qalay tabi'ladi'?
2. Bir san yekinshi sanni'n' neshe procentin quraytug'i'nli'g'i' qalay tabi'ladi'?

Klasta wori'nlanatug'i'n shi'ni'g'i'wlar



- 1111.** Ati'zdi'n' 1 procentine ma'sh yegildi. Yeger 3,25 ke ma'sh yegilgen bolsa, pu'tin ati'zdi'n' maydani'n tabi'n'.
- 1112.** Yeger zalda ha'zir bolg'anlardi'n' 1 procenti – 7 adamdi' qurasa, zalda neshe adam bar?
- 1113.** Motosiklshi' bir ku'nde belgili arali'qti' basi'p wo'tti. Bul arali'qti'n' 1 procenti 3,2 km bolsa, pu'tin arali'qti' tabi'n'.
- 1114.** Jer maydani'ni'n' 4 procenti mashina turi'wi' ushi'n ajrati'lg'an. Mashina turatug'i'n maydan $38,4\ m^2$ qa ten' bolsa, jer maydani'n tabi'n'.
- 1115.** Neftti aydag'anda 30 % kerosin ali'nadi'. Yeger a) 20 t; b) 12 t; d) 42,2 t kerosin ali'ng'an bolsa, qansha neft aydal'g'an?
- 1116.** Biydaydan 80 % un ali'nadi'. Yeger 440 kg un ali'ng'an bolsa, qansha biyday digirmannan jedirilgen? 2,5 t biydaydan qansha un ali'nadi'?
- 1117.** Rano puli'ni'n' 60 procentine kitap sati'p aldi'. Qalg'an 2000 swmg'a kinog'a bilet aldi'. Ranoda qansha pul bol'g'an?



- 1118.** Bag'ta 850 tu'p terektin' 680 i miyweli terek. Miyweli terekler bag'dag'i' tereklerdin' neshe procentin quraydi'?

1119. Kesteni tolti'ri'n'.

Procent	1%	3%	10%	20%	25%	28%	45%	50%	63%	75%	80%	95%
A'piwayi' bo'lshek												
Wonli'q bo'lshek												

1120. Jumi'sshi' reje boyi'nsha 35 detal jasawi' kerek yedi. Biraq, wol rejeden arti'qsha 14 detal soqti'. Jumi'sshi' rejeni neshe procent wori'nlag'an?

1121. a) 30 sani' 40 ti'n'; b) 63 sani' 75 tin'; d) 114 sani' 384 tin'; e) 4,71 sani' 31,4 tin'; f) 36,9 sani' 12,3 tin' qansha procentin quraydi'?

U'lg'i: a) $30 : 40 = 0,75 = 0,75 \cdot 100\% = 75\%$.

1122. Yeger yeritpe 60 g duz ha'm 140 g suwdan tayarlang'an bolsa, Yeritpede neshe procent duz bar?

1123. Palto 64 000 swm turadi'. Birinshi ma'rte woni'n' bahasi' 10 procentke, yekinshi a'rtebe bolsa 1800 swmg'a arzanlasti'rdi'. yekinshi ma'rte palto neshe procentke tu'sirilgen?

1124. Buyi'rtpa boyi'nsha usta 8 saatta 80 detal sog'i'wi' kerek yedi. 7 saattan son' ustabarli'q detaldi'n' 90 procentin soqti'. Usta sonday miynet wo'nimdarli'li'q penen islep, buyi'rtpani' wo'z waqti'nda wori'nlay alama?

1125. Bronza qalayi' menen misti'n' aralaspasi'nan ibarat. 6 kg qalayi' ha'm 34 kg mi'stan ibarat bronzada mi's aralaspasi'n' neshe procentin quraydi'?

1126. a) 32 sani' 40 tan neshe procentke kishi? b) 40 sani' 32 sani'nan neshe procent u'lken?



U'yde wori'nlanatug'i'n shi'ni'g'i'wlar

1127. Fermada 250 bas si'yi'r ha'm buzaw bar. Buzawlar barli'q mallardi'n' 22 procentin quraydi'. Fermada neshe buzaw bar?

1128. Gerbishti tasi'wda woni'n' 2 procentti si'ndi', bul bolsa 1500 di quraydi'. Ja'mi neshe gerbish tasi'lg'an?

1129. Bir qapta 80 kg un bar, yekinshisinde wonnan 20 procent kem. Yekinshi qapta neshe kg un bar?

1130. Temirshi menen sha'kirti 1200 detal tayarladi'. Sha'kirti barli'q detaldi'n' 30 procenttin tayarladi'. Temirshi neshe detal tayarlag'an?



1131. 220 at ha'm tayi'nshaqlar ali'p kelindi. Tayi'nshaqlar barli'q ji'lqi'ni'n' 15 procentin quraydi'. Neshe tayi'nshaq ali'p kelingan?

1132. Jer betinin' maydani' 510,1 mln km² qa ten' boli'p, woni'n' 149,2 mln km² ti' qurg'aqli'q, qalg'ani'n' bolsa suw quraydi'. Jer betinin' neshe procentti suw menen qaplang'an?



- 1133.** Mazali' shay payda yetiw ushi'n 200 gramli'q stakang'a 2 shay qasi'q qumsheker sali'nadi'. Yeger bir shay qasi'qtag'i' qumsheker massasi' 10 g bolsa, mazali' shayda neshe procent qumsheker bar?
- 1134.** Klasta 40 woqi'wshi' bar. Yer balalar klastag'i' barli'q woqi'wshi'lardi'n' 55 procentin quraydi'. Klastag'i' qi'z balalar neshe procentti quraydi'? Klasta neshe qi'z woqi'ydi'?
- 1135.** Su'tten 10 % qaymaq ali'nadi'. 32,8 kg su'tten qansha qaymaq ali'nadi'? 58,7 kg su'tten ne?
- 1136.** Zamari'q qurg'ati'lg'anda massasi'ni'n' 79 procentin jog'altadi'. Yeger 20 kg zamari'q qurg'ati'lsa qancha qurg'ati'lg'an zamari'q qaladi'?

Bilimin'izdi si'nap ko'rin'!



Bul bap materiallari'n u'yrenip shi'g'i'p, to'mendegi ma'selelerdi sheshe ali'wi'n'i'z sha'rt! Qadag'alaw jumi'si' aldi'nan wo'zin'izdi si'nap ko'rin'!

12-qadag'alaw jumi's u'lgisi

1. Maydan beti 260 ga. Buni'n' 35 % piyaz yegilgen. Piyaz qansha maydang'a yegilgen?
2. An'latpani'n' ma'nisin tabi'n': $201 - (176,4 : 16,8 + 9,68) \cdot 2,5$.
3. Kitapxanadag'i' kitaplardi'n' 12 % so'zlikler quraydi'. Yeger so'zlikler sani' 900 bolsa, kitapxanada ja'mi qansha kitap bar?
4. Ten'lemeni sheshin': $12 + 8,3x + 1,5x = 95,3$.
5. Si'm worami' 72 m bolip, wonnan 18 m si'm kesip ali'ndi'. Si'm worami'na si'mtin' neshe procenti qaldi'?

Qi'zi'qli' matematikag'a tiyisli ma'seleler



3 ha'm 5 litrlik i'di'slar bar. Wolar ja'rdeminde suw krani'nan 4 litr suw quyi'p ali'w mu'mkin be?



48.1. Mu'yesh tu'sinigi

O noqattan shi'g'i'wshi' yeki: OA ha'm OB nuri'nan ibarat figurag'a *mu'yesh* dep ataladi' (1-su'wret). O noqat *mu'yeshin' ushi'*, OA ha'm OB nurlar bolsa *mu'yeshin' ta'repleri* dep ataladi'.

1-su'wrettegi mu'yesh su'wretlengen. Wonda O mu'yeshin' ushi', OA ha'm OB nurlar bolsa woni'n' ta'repleri. Bul mu'yesh jazi'wda « AOB mu'yesh» ya'ki « BOA mu'yesh» tu'rinde belgilenedi. Bunda mu'yeshin' to'besi wortag'a jazi'ladi'.

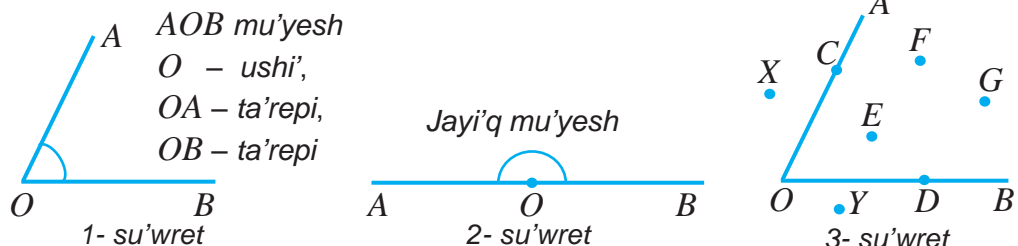

Sunday-aq, mu'yeshi ushi'ndagi' bir ha'rip penen de belgileniwi mu'mkin. Ma'selen, « O mu'yesh». Geyde mu'yesh so'zi warni'na « \angle » belgi qollani'ladi'. Bul jag'dayda, $\angle AOB$, $\angle BOA$ ya'ki $\angle O$ ko'rinishinde belgilenedi.

AB turwi' si'zi'qta O noqati'n belgileymiz (2- su'wret). Na'tiyjede, OA ha'm OB nurlar payda boladi'. Bul nurlar *jayi'q mu'yeshi* ani'qlaydi'.

3- su'wrette AOB mu'yesh ha'm bir neshe noqatlar berilgen. Bul noqatlar haqqi'nda ga'p ketkende, C ha'm D noqatlar – AOB mu'yesh ta'replerinde, E, F, G , noqatlari' – F ha'm G mu'yeshin' ishki oblasti'nda, X ha'm Y noqatlari' bolsa mu'yeshin' si'rtqi' oblasti'nda jati'r dep aytami'z.

48.2. Mu'yeshlerdi sali'sti'ri'w

Mu'yeshlerdi bir-birine u'stpe-u'st qoyi'w arqali' sali'sti'ri'w mu'mkin (4.- su'wret). Buni'n' ushi'n, wolardi' birewden ta'repleri u'spe-u't tu'setug'i'nday yetip u'stpe-u'st qoyi'ladi'. Yeger bunda wolardi'n' yekinshi ta'repleri de u'stpeu'st tu'sse, wolar *ten'* boladi'.

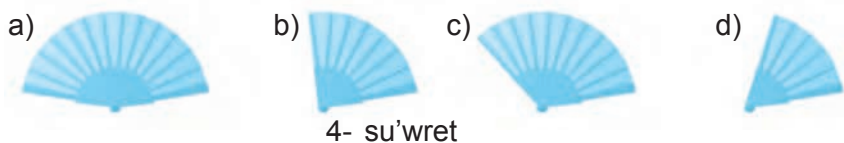

4- su'wret

Yeki mu'yeshi wo'z-ara sali'sti'ri'w – birin yekinshisinin' u'stine qoyi'w arqali' a'melge ashi'ri'ladi'.

Yeger mu'yeshlerdi u'spe-u'st qoyg'anda, (5.a-su'wret) yekinshi ta'repleri u'stpe-u'st tu'spese, qaysi' mu'yeshin' yekinshi ta'repi basqasi'ni'n' ishki oblasti'nda jatsa, sol mu'yesh kishi boladi' (5.b-su'wret).

Demek, bul mu'yeshler wo'z-ara ten'. Bul $\angle A = \angle B$ tu'rinde jazi'ladi'.

Ten' mu'yeshler su'wrette bir qi'yli' sandag'i' jayshalar menen aji'rati'p ko'r-setiledi.



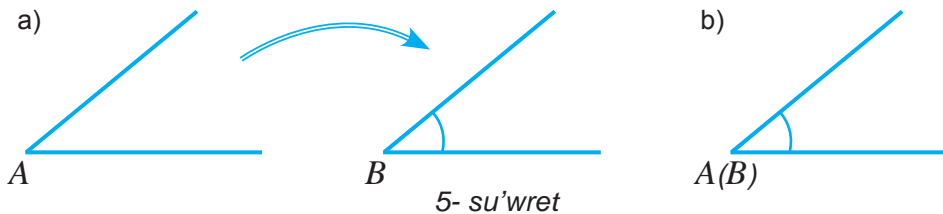

AOB mu'yeshtin' O ushi'nan OE nuri'n wo'tkizemiz (6a-rasm). OE nuri' mu'yeshti AOE ha'm EOB mu'yeshlarga bo'ledi. Bul mu'yeshtin' ha'r biri AOB mu'yeshinen kishi boladi' ha'm wol to'mendegishe jazi'ladi':

$$\angle AOE < \angle AOB, \quad \angle EOB < \angle AOB.$$

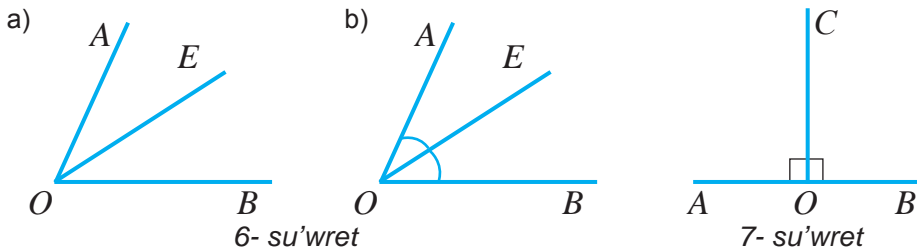

Eger AOE ha'm EOB mu'yeshleri ten' bolsa, OE nuri' AOB mu'yeshti ten' yekige bo'ledi. Bul jag'dayda, OE nuri' AOB **mu'yeshtin' bissektriyasi'** dep ataladi'.

6.b-su'wrette OE nur AOB mu'yeshtin' bissektriyasi'.

48.3. Tuvri' mu'yesh

AOB jayi'q mu'yeshtin' O ushi'nan OC bissektriyasi'n wo'tkeremiz (7- su'wret). Korip turg'ani'n'i'zday, payda bolg'an AOC ha'm COB mu'yeshler wo'z-ara ten' boladi': $\angle AOC = \angle COB$. Bul mu'yeshler **tuwri' mu'yeshler** dep ataladi'. Tuvri' mu'yesh 7- su'wrettegidey si'ni'q si'zi'q penen aji'rati'adi'.

Solay yetip, jayi'q mu'yesh bissektriyasi' woni' yeki tuwri' mu'yeshke aji'ratadi' yeken. Bunnan to'mendegi juwmaqqqa kelemiz:

Tuwri' mu'yesh jayi'q mu'yeshtin' yari'mi'na ten'.



Tuwri' mu'yeshlerdi si'zi'w ushi'n 8- su'wrette su'wretlengen u'shmu'yeshli si'zg'i'shtan paydalaniladi'. Bir ta'repi OA nurdan ibarat tuwri' mu'yesh si'zi'w ushi'n:

1) U'shmu'yeshli si'zg'i'shti'n' tuwri' mu'yeshli ushi'n O noqatta, bir ta'repi bolsa OA nurda jatatug'i'n etip qoyiladi'.

2) Si'zg'i'shti'n' yekinshi ta'repi boylap OB nuri' si'zi'ladi'.

3) Payda bolg'an AOB mu'yeshi tuwri' mu'yesh boladi'.

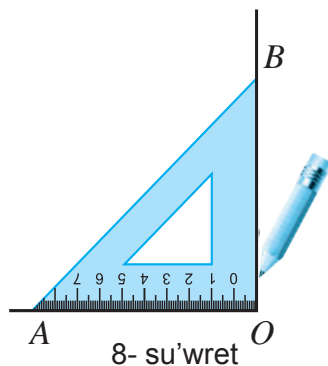

9-su'wrette su'wretlengen saatlardi'n' saat ha'm minut tilleri arasi'ndag'i' mu'yeshlerdi belgilen'. Yen' u'lken mu'yesh qaysi' su'wrette su'wretlengen? Yen' kishi mu'yesh qaysi' su'wrette su'wretlengen? Qaysi' su'wretlerde ten' mu'yeshler su'wretlengen?

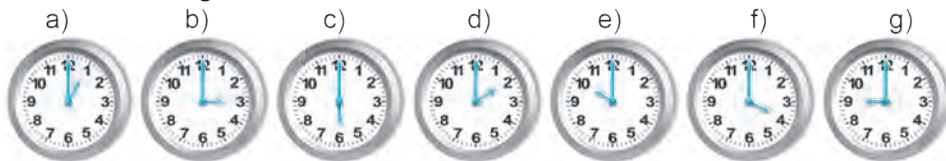

9- su'wret



Sorawlarg'a juwap berin'!

1. Mu'yesh dep nege ayti'ladi'?
2. Mu'yesh qanday belgilenedi'?
3. Ten' mu'yeshler dep qanday mu'yeshlarga ayti'ladi'?
4. Jayi'q mu'yeshdin' yari'mi' qanday mu'yesh boladi'?



Klasta wori'nlanatug'i'n shi'ni'g'i'wlar

1137. 10-su'wrette su'wretlengen mu'yeshlerdi ayti'n'. Wolardi'n' to'besi ha'm ta'replerin ani'qlan'.

1138. 11-su'wrette su'wretlengen noqatalardi'n' qaysi'lari: a) mu'yeshde; b) mu'yeshdin' ishki oblasti'nda; d) mu'yeshdin' si'rtqi' oblasti'nda jatadi'?

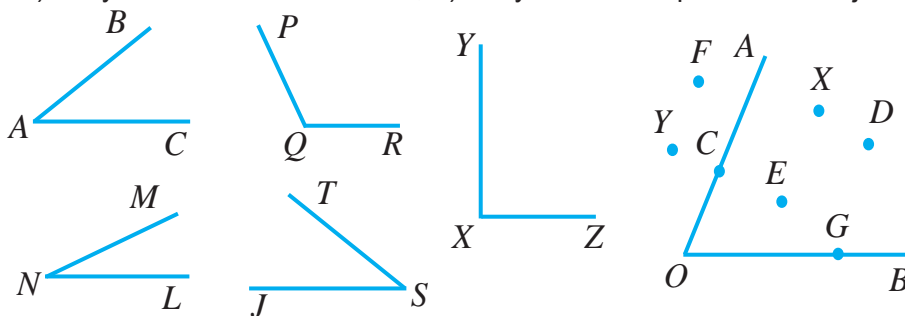

10- su'wret

11- su'wret

1139. Qag'az betine yeki mu'yesh si'zi'n' ha'm wolardi' qi'yi'p ali'n'. Bul mu'yeshlerdi bir birinin' u'stine qoyi'w arqali' wo'z ara sali'sti'ri'n'.

1140. 10-su'wrettegi mu'yeshlerdi ko'z benen shamalap wo'z ara sali'sti'ri'n'. wolardi'n' arasi'nda jayi'q yamasa tuwri' mu'yesh bar ma?

1141. Qag'az betine qa'legen mu'yeshdi si'zi'n'. Betti bu'giw arqali' woni' ten' yekige bo'lin'.

1142. O noqati'nan shi'g'i'wshi' OA , OB , OC ha'm OD nurlari'n' si'zi'n'. Payda bolg'an barli'q mu'yeshlerdi jazi'n'.



1143. 10-su'wrette su'wretlengen BAC mu'yeshdin' u'stine ji'lti'r qag'azdi' qoyi'p, wonnan nusqa ali'n'. U'lgini qalg'an mu'yeshler u'stine qoyi'p, wolar arasi'nan BAC mu'yeshke: a) ten'; b) kishi; d) u'lken bolg'anlari'n' ani'qlan'.



- 1144.** CMD mu'yesh si'zi'n'. MN ha'm ML nurlar menen woni' bo'leklerge aji'rati'n'. Payda bolg'an mu'yeshlerdi jazi'n'.
- 1145.** Jayi'q mu'yesh si'zi'n' ha'm woni' belgilen'. U'shmu'yeshli si'zg'i'sh ja'rdeminde woni' yeki tuwri' mu'yeshke bo'lin'. Tiyisli belgilewlerdi wori'nlan'. Jayi'q mu'yesh qaysi' mu'yeshler qosi'ndi'si'nan ibarat yekenligin ani'qlan' ha'm jazi'n'.
- 1146.** Saatti'n' minut mili qansha waqi'tta tuwri' mu'yeshke buri'ladi'? Qansha waqi'tta jayi'q mu'yeshke buri'ladi' (12- su'wret)?

U'yde wori'nlanatug'i'n ma'seleler



- 1147.** 13-su'wrette su'wretlengen mu'yeshlerdi belgilen' ha'm barli'g'i'n jazi'n'.
- 1148.** U'shmu'yeshli si'zg'i'sh ja'rdeminde 13- su'wrette su'wretlengen mu'yesh arasi'nan tuwri' mu'yeshdi tabi'n'?

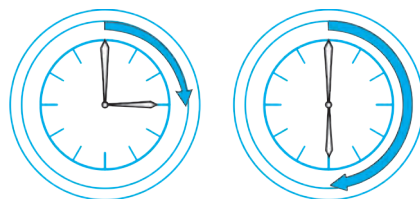

12- su'wret



13- su'wret

- 1149.** 14-su'wrette su'wretlengen A mu'yeshdin' u'stine ji'lti'r qag'azdi' qoyi'p, wonnan nusqa ali'n'. U'lgi ja'rdeminde qalg'an mu'yeshler arasi'nan A mu'yeshke: a) ten'; b) kishi; d) u'lken bolg'anlari'n ani'qlan'.

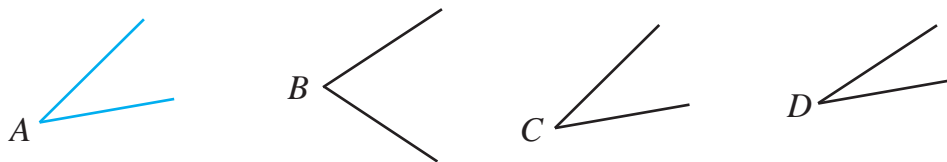

14- su'wret



- 1150.** O noqati'nan shi'g'i'wshi' OP , OR , OS nurlari'n si'zi'n'. Payda bolg'an barli'q mu'yeshlerdi jazi'n'. Bul nurlar tegislikti neshe bo'lekke aji'ratadi'?
- 1151.** Da'pter ketekshelerinen paydalani'p tuwri' mu'yesh si'zi'n' ha'm woni' belgilen'.
- 1152.** U'shmu'yeshli si'zg'i'sh ja'rdeminde: a) ta'repleri 4 sm ha'm 6 sm bolg'an tuwri' mu'yeshlik; b) ta'repi 5 sm ge ten' kvadrat si'zi'n'. Woni' belgilen' ha'm payda bolg'an tuwri' mu'yeshlerdi jazi'n'.
- 1153.** Tuwri' mu'yesh bissektrisasi' woni' neshe gradusli' mu'yeshlerge bo'ledi'?

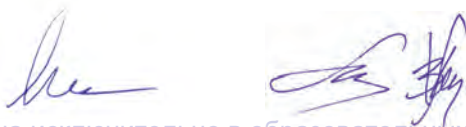

Ha'r qanday shamani' wo'lshew ushi'n wo'lshe birligin tan'law kerek boladi'. Mu'yeshlerdi wo'lshew ushi'n da aldi'n wo'lshe birligin tan'laymi'z.

Jayi'q mu'yeshi woni'n' to'besinen shi'g'i'wshi' nurlar menen 180 ten' mu'yeshlerge bo'lemiz (1-su'wret). Bul mu'yeshlerdin' qa'legen birewin birlik mu'yesh si'pati'nda alami'z. Woni'n mu'yesh ma'nisin "1 gradus" dep alami'z ha'm «1⁰» tu'rinde belgileymiz.

Mu'yeshin' gradus wo'lshe wo'ni'n' ishki woblastti'nda birlik mu'yeshin' neshewi jaylasqanli'g'i'n bildiredi.

Jayi'q mu'yeshin' gradus wo'lshe wo'lshe 180⁰qa ten'. Sebebi woni' ishki oblasti'nda 180 birlik mu'yesh jaylasqan (2-su'wret).

Wonda tuwri' mu'yesh 90⁰ qa ten' boladi'. Sebebi wol jayi'q mu'yeshlerdin' yari'mi'na ten'.

Mu'yeshler transportir dep atalg'an a'sbap penen wo'lshe nedi. Transportirdin' tiykari' si'zgi'shtan, joqari' bo'legi yari'm do'n'gelek formasi'ndagi' figuradan ibarat (3-su'wret). Yari'm

do'n'gelek worayi'tiykari'ndagi' kishi si'zi'q penen belgilengen boladi' Woni' transportir worayi' dep ataymi'z. Transportirdin' shkalasi' si'zi'qlar menen 180 ten' dog'alarg'a bo'lingen. Ha'r bir dog'a 1⁰li' mu'yeshi ani'qlaydi'. 3-su'wrette transportir ja'rdeminde *AOB* mu'yesh wo'lshe wo'lshe ko'rsetilgen.

Mu'yeshi wo'lshe wo'lshe ushi'n transportir tiykari'ndagi' si'zgi'sh mu'yesh ta'replerinen birinin' u'stine, mu'yeshin' to'besi transportir worayi' menen u'ztpe-u'st tu'setug'i'n yetip qoyi'ladi'. Sonda mu'yeshin' yekinshi ta'repi transportirdin' qaysi' shkala ko'rsetkishinen wo'tse, mu'yeshin' gradus wo'lshe wo'lshe sog'an ten' boladi'. $AOB = 60^0$.

Ten' mu'yeshlerdin' gradus wo'lshe wo'lshe de ten' boladi'. Yeki mu'yeshin' u'lkeninin' gradus wo'lshe wo'lshe u'lken, kishinin' gradus wo'lshe wo'lshe bolsa kishi boladi'.

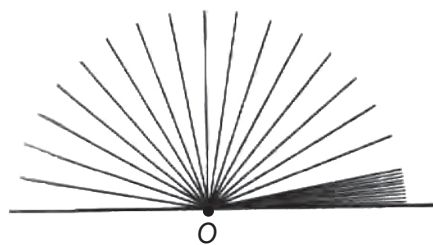

1- su'wret

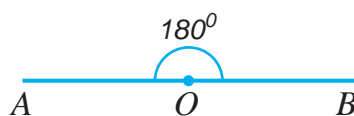

2- su'wret

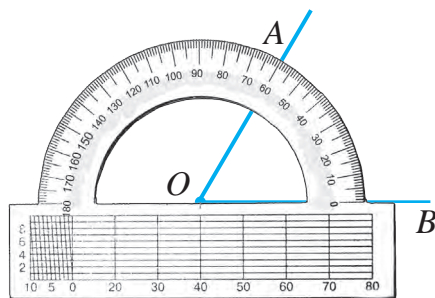

3- su'wret

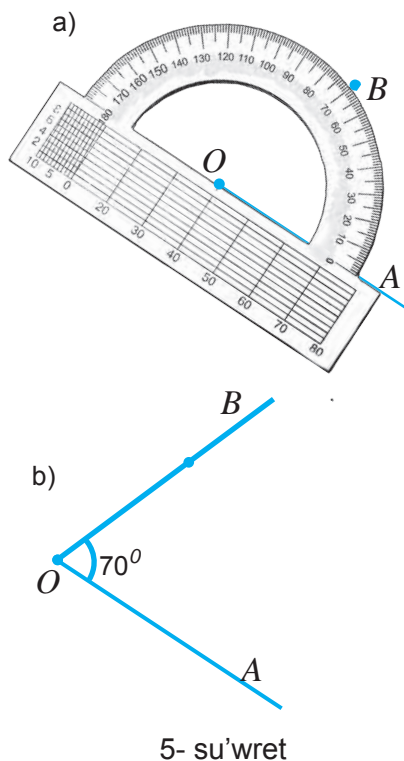
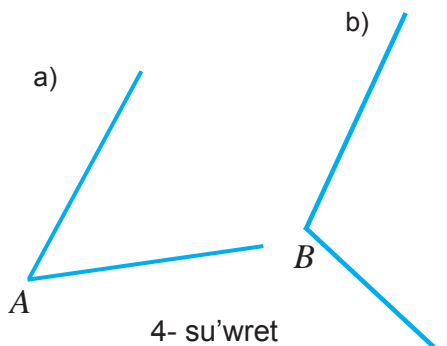

Yeger mu'yeshtin' gradus wo'lishemi 90° , tan kishi bolsa, bunday mu'yesh *su'yir mu'yesh* dep ataladi'. Gradus wo'lishemi 90° tan u'lken ha'm 180° tan kishi bolg'an mu'yeshke *dog'al mu'yesh* delinedi. 4.a-su'wrette su'yir, 4.b-su'wrette bolsa dog'al mu'yesh su'wretlengen.

Transportir ja'rdemide berilgen gradus wo'shemine iye bolg'an mu'yeshlerdi de jasaw mu'mkin.

Mi'sal. Bir ta'repi OA nuri'nan ibarat bolg'an 70° li' mu'yesh jasan'.

Sheshiliwi. Jasaw to'mendegishe a'melge asi'riliadi':

1. Transportir tiykari'ndagi' si'z-g'i'shti' berilgen OA nurg'a transportir worayi' O noqati' menen u'stpe-u'st tu'setug'i'nday yetip qoyami'z (5.a-su'wret).

2. Transportir shkalasi'ndagi' 70° qa sa'ykes si'zi'q tuwri'si'nda B noqati'n belgileymiz.

3. OB nuri'n wo'tkizemiz (5.b-su'wret). Payda bolg'an AOB mu'yesh 70° li' boladi'.

Mu'yesh gradus wo'lisheminin' ja'ne basqa *minut* ha'm *sekund* dep atali'wshi' wo'lishem birlikleri de bar. $1^\circ = 60$ minuttan, 1 minut bolsa 60 sekundtan ibarat. Bul $1^\circ = 60'$, $1' = 60''$ tu'rinde belgilenedi.

Sorawlarg'a juwap berin'!



1. Mu'yesh wo'lishew birligi si'pati'nda ne ali'nadi'?
2. Mu'yesh gradus wo'lishemin tabi'w degende neni tu'sinesiz?
3. Jayi'q ha'm tuwri' mu'yesh tin' gradus wo'lishemi nege ten'?
4. Su'yir ha'm dog'al mu'yesh lerge ta'riplep berin'.
5. Transportir jaydemide mu'yeshler qalay wo'lisheniwi ha'm jasali'wi'n tu'sindirip berin'.
6. Ja'ne qanday mu'yesh wo'lishew birliklerin bilesiz?



Klasta wori'nlanatug'i'n shi'ni'g'i'wlar

- 1154.** Qulashi'n'i'zdi' jayi'p qollari'n'i'z benen: a) 90^0 li'; b) 180^0 li' mu'yeshlerdi ko'rsetin'.
- 1155.** Tik turg'an jerin'izde: a) 90^0 ; b) 180^0 qa burili'n';
- 1156.** Saat minut tili:
a) 15 minut; b) yari'm saat; d) 1 saatta neshe gradusqa buriladi'?
- 1157.** Gradus wo'lshemi berilgen to'mendegi mu'yeshlerdin' qaysi' biri su'yir mu'yesh? Qaysi' biri dog'al mu'yesh? 22^0 , 165^0 , 23^0 , 90^0 , 178^0 , 154^0 , 101^0 , 99^0 .
- 1158.** Yeki su'yir ha'm yeki dog'al mu'yeshler si'zi'n'. Wolardi' belgilen'. Transportir ja'rdemide wo'lshen' ha'm wo'lshem na'tiyjelerin jazi'n'.
- 1159.** Transportir ja'rdemide: a) 53^0 ; b) 47^0 , d) 105^0 , e) 173^0 li' mu'yesh jasan';
- 1160.** 6-su'wrette BAC mu'yeshi 28^0 qa, BAD mu'yeshi bolsa 84^0 qa ten'. CAD mu'yeshnin' gradus wo'lshemi nege ten'?



- 1161.** Da'pter ketekshelerinen paydalani'p. a) 45^0 ; b) 135^0 li' mu'yesh jasan'.
- 1162.** Shen'ber si'zi'n'. Woni'n' yeki radiusi'n sonday yetip si'zi'n', a) wolar arasi'ndagi' mu'yesh: a) 45^0 ; b) 90^0 ; d) 135^0 ; e) 180^0 bolsi'n.
- 1163.** 7-su'wrette ja'rdemide, $\angle COB$ mu'yeshin tabi'n'.

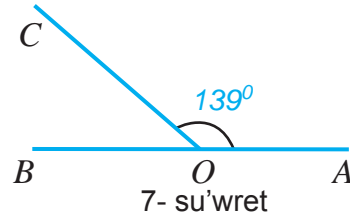
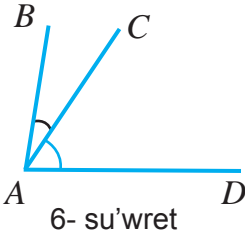

- 1164.** 8- su'wrettegı $\angle AOB$ gradus wo'lshemi nege ten'?

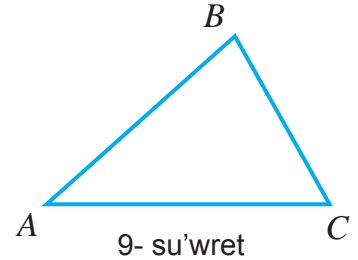
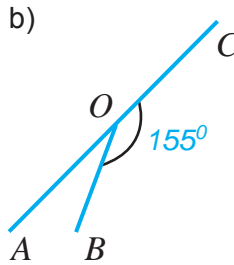
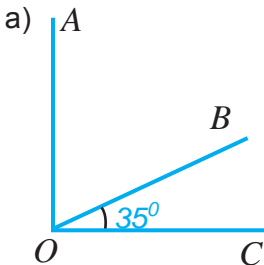

- 1165.** A'meliy jumi's. 9-su'wrette berilgen ABC u'shmu'yeshliginin' ABC , BCA ha'm CAB mu'yeshlerin transportir ja'rdemide wo'lshen'. Bul mu'yeshlerdin' qosi'ndi'si'n yesaplan'. Bul jumi'sti' basqa u'shmu'yeshlik si'zi'p, ja'ne wori'nlan', na'tiyjelerdi sali'sti'ri'n'. Yeger ani'q wo'lshep duri's yesaplag'an bolsan'i'z u'shmu'yeshliktin' to'mendegi qa'siyetine iye bolasi'z:
u'shmu'yeshliktin' mu'yeshlerinin' qosi'ndi'si' 180^0 qa ten'.



- 1166.** U'shmu'yeshliktin' yeki mu'yeshi 35^0 ha'm 67^0 . Joqari'dag'i' a'meliy jumi's na'tiyjesinen paydalani'p, u'shmu'yeshliktin' u'shinshi mu'yeshin tabi'n'.
- 1167.** $\angle AOB = 120^0$ boli'p, OC nur woni' yeki bo'lekke bo'ledi. Yeger AOC mu'yesh COB mu'yeshitin' 0,2 bo'limin qurasa, AOC mu'yeshiti tabi'n'.
- 1168.** a) 21^0 ; b) 43^0 ; d) $16^0 20'$; e) $31^0 37' 17''$ ti' sekundlarda an'lat i'n.
- 1169.** a) $11^0 30'$; b) $43^0 40'$; d) $76^0 20' 30''$ graduslarda an'lati'n'.

U'yde wori'nlanatug'i'n ma'seleler



- 1170.** Gradus wo'lshe mi berilgen to'mendegi mu'yeshlerdin' qaysi' biri su'yir mu'yesh? Qaysi' biri dog'al mu'yesh? 92^0 ; 16^0 ; 145^0 ; 90^0 ; 78^0 ; 132^0 ; 112^0 ; 98^0 .
- 1171.** Bir su'yir ha'm bir dog'al mu'yesh si'zi'n'. Wolardi' belgilen'. Transportir ja'rdeminde wo'lshe n' ha'm wo'lshe m na'tiyjelerin jazi'n'.
- 1172.** Transportir ja'rdeminde: a) 30^0 ; b) 73^0 , d) 115^0 , e) 135^0 li' mu'yesh jasan'.
- 1173.** 10-su'wrette ja'rdeminde, a) AOB ; b) DOK ; d) COF ; e) FOM ; f) COL ; g) AOM ; h) KOE ; k) LOC ; l) EOG ; mu'yeshlerinin' gradus wo'lshe mi nege ten'.

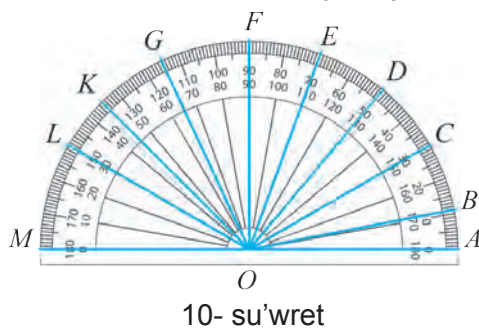

- 1174.** 11- su'wrette BAC mu'yesh 136^0 , BAD mu'yesh bolsa 56^0 ten'. CAD mu'yesh nege ten'?

- 1175.** Shen'ber si'zi'n'. Transportirdan paydalani'p woni'n' yeki radiusi'n sonday yetip si'zi'n', wolar arasi'ndag'i' mu'yesh: a) 60^0 ; b) 120^0 ; d) 30^0 ; e) 150^0 bolsi'n.
- 1176.** 12- su'wrettegi $\angle AOB$ nege ten'?
- 1177.** 13- su'wrettegi $\angle AOB$ nimaga teng?
- 1178.** U'shmu'yeshlktin' bir mu'yeshi 63^0 , yekinshi mu'yeshi bolsa 42^0 qa ten'. Woni'n' u'shinshi mu'yeshin tabi'n'.
- 1179.** a) 33^0 ; b) $11^0 10'$; d) $76^0 12' 39''$ ti' sekundlarda an'lati'n.

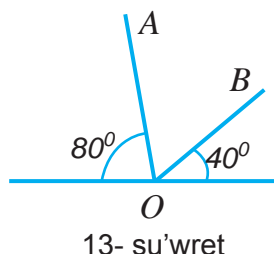
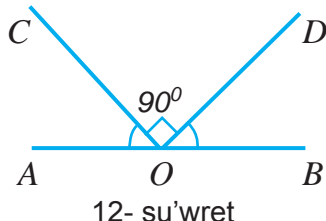
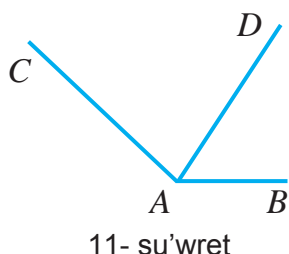

Mag'li'wmatlardi' do'n'gelek diagramma ko'riniside de su'wretlew mu'mkin. A'dette, do'n'gelek diagrammalar bir pu'tin na'rsenin' quram bo'lekleri arasi'ndagi' qatnasi'qlardi' ko'rgizbeli yetip su'wretlew ushi'n du'ziledi.

Mi'sali', mektep ja'mi woqi'wshi'lar sani'ni'n' klaslar boyi'nsha bo'liniwi, ma'mleket xalqi'ni'n' milliy qurami', shan'araqti'n' ja'mi qa'rejetlerindegi tu'rli qa'rejetinin' u'lesi. Aralaspadagi' tu'rli metallar u'lesi ha'm tag'i' basqa.

1- mi'sal. Massasi' 12 kg bolg'an aralaspini'n' 2 kg mi' duz, qalg'ani'n' suw quraydi'. Bul mag'li'wmatlar tiykari'nda do'n'gelek diagramma du'zin'.

Sheshiliwi. Do'n'gelek worayi'n jayi'q mu'yeshitin' to'besi dep alsaq, pu'tin do'n'gelekte 2 jayi'q mu'yesh qaplaydi' (1-su'wret).

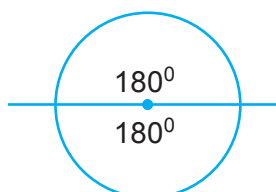

1- su'wret

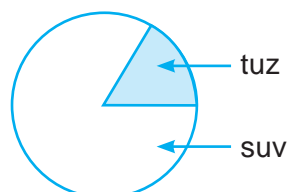

2- su'wret

Demek, pu'tin do'n'gelektin' gradus wo'lishemin $2 \cdot 180^\circ = 360^\circ$ dep alsaq boladi'.

Ma'sele sha'rt boyi'nsha, 12 kg aralaspini' pu'tin do'n'gelek (360°) dep alami'z. Bul jag'dayda, 1 kilogrammli'q aralaspag'a $360 : 12 = 30^\circ$ sa'ykes keledi.

Demek, 2 kg duz $2 \cdot 30^\circ = 60^\circ$ li' mu'yesh penen su'wretlenedi.

Ani'qlang'an ma'nisler tiykari'nda do'n'gelek diagramma quraymi'z. Buni'n' ushi'n do'n'gelek si'zi'p, do'n'gelektin' worayi'nda bolg'an 60° li' mu'yesh boylap yeki radius wo'tkizsek, payda bolg'an do'n'gelek bo'legi duzdi'n' mug'dari'n ani'qlaydi' (2- su'wret).

Demek, do'n'gelektin' qalg'an bo'legi aralaspadagi' suwdi'n' mug'dari'n ani'qlaydi'.

Payda bolg'an figura aralaspadagi' duz ha'm suw mug'dari'n ko'rsetiwshi do'n'gelek diagrammadan ibarat boladi'.

Geypara jag'daylarda diagramma du'ziwde pu'tin do'n'gelekti ko'birek bo'leklerge bo'liwge tuwra keledi.

2- mi'sal. Awi'l puqaralari' ji'yi'ni'na wo'tkizilgen saylawda ja'mi 12 000 saylawshi' qatnasti'. Wolardi'n' 5 400 A talabang'a, 2 100 B talabang'a, 3 300 D talabang'a, 1 200 E talabang'a dawi's berdi.

Saylaw na'tiyjesin ko'rsetiwshi do'n'gelek diagrammasi'n du'zin.

Sheshiliwi. Pu'tin do'n'gelek (360°) – barli'q 12 000 saylawshi'lar sani'n' su'wretlegen. Wonda bir saylawshi'g'a $360 : 12000 = 0,03^\circ$ gradusli' mu'yesh



sa'ykes keledi. Yendi bir talabang'a dawi's bergen saylawshi'lar sani'na sa'ykes kelgen mu'yesh u'lkenliklerin tabami'z:

$$A \text{ talaban ushi'n: } 5400 \cdot 0,03 = 162^{\circ}$$

$$B \text{ talaban ushi'n: } 2100 \cdot 0,03 = 63^{\circ}$$

$$D \text{ talaban ushi'n: } 3300 \cdot 0,03 = 99^{\circ}$$

$$E \text{ talaban ushi'n: } 1200 \cdot 0,03 = 36^{\circ}$$

Do'n'gelek worayi'ni'n' mu'yeshlerdin' to'besi dep ali'p, sa'ykes mu'yeshlerin transportir ja'rdemide si'zsaq, tiyisli diagrammani' payda yetemiz (3-su'wret).

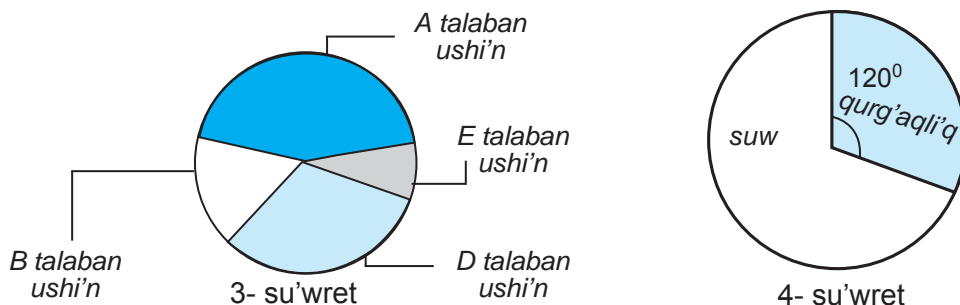

Sorawlarg'a juwap berin'?



1. Do'n'gelek diagrammalar qanday maqsetlerde du'ziledi?
2. Do'n'gelek diagrammalardi' du'ziw bari'si'n mi'salda tusindirir'.

Klasta wori'nlanatug'i'n shi'ni'g'i'wlar



1180. To'mendegi kestede du'nya wokeanlari'ni'n' maydani' berilgen. wonnan paydalani'p do'n'gelek diagramma du'zin'.

Ti'ni'sh okeani'	Atlantika okeani'	Hind okeani'	Arqa muz okeani'
180 mln km ²	92 mln km ²	75 mln km ²	13 mln km ²

1181. 4-su'wrette jer ju'zinde qurg'aqli'q ha'm wokean suwlari' iyelegen maydanlardi'n' diagrammasi' su'wretlengen. wol tiykari'nda jer betinin' qanday bo'legin wokean suwlari' ha'm qanday bo'legin qurg'aqli'q quraytug'i'ni'n' ani'qlan'.

1182. Miyweden tayarlanatug'i'n ishimliktin' qurami' 600 g miywe, 1200 g suw ha'm 360 g qumshekerden ibarat. Bul mag'li'wmatlardan paydalani'p, ishimlik qurami'nko'rsetiwshi do'n'gelek diagramma du'zin'.

1183. Klass woqi'wshi'lari' wortasi'nda wo'tkerilgen sorawda, 36 woqi'wshi'ni'n' 12 i jasi'l ren'di, 6 i qi'zi'l ren'di, 8 i aq ren'di, 4 i ko'k ren'di, qalg'anlari' bolsa sari' ren'di xosh ko'riwi ani'qlandi'. Bul mag'li'wmatlardan paydalani'p, soraw na'tiyjelerin ko'rsetiwshi do'n'gelekli diagramma du'zin'.



- 1184.** Avtosalon bir ayda 20 “Spark”, 12 “Lasetti”, 16 “Nexia”, 24 “Kobalt” ha’m 18 “Matiz” markasi’nda jen’il avtomobillerdi bo’lek sattı. Avtosalonni’n’ ayli’q sati’w qurami’n ko’rsetiwshi do’n’gelek diagramma du’zin’.
- 1185.** To’mendegi berilgen kestenin’ bos ketekshelerin toltiri’n’ ha’m wonnan paydalani’p jer materikler maydani’n ko’rsetiwshi do’n’gelek diagramma du’zin’.

Materikler	Maydani’ (mln km ²)	Sa’ykes mu’yesh gradusi’
Aziya	43,4	
Amerika	42	
Afrika	30,3	
Antarktida	14,1	
Evropa	11,5	
Avstraliya	8,7	
Ja’mi		360 ⁰



- 1186.** To’mendegi berilgen kestenin’ bos ketekshelerin toltiri’n’ ha’m wonnan paydalani’p Jer ju’zindagi tarqalg’an qurg’aqli’q tu’rleri maydani’n ko’rsetiwshi do’n’gelek diagramma du’zin’.

Qurg’aqli’q tu’rleri	I’yelegen maydani’ (mln km ²)	Sa’ykes mu’yesh gradusi’
Tog’aylar	57	
Sho’ller	24	
Sahralar ha’m	54	
Su’riletug’i’n jerler	15	
Ja’mi		360 ⁰

- 1187.** 5-klass woqi’wshi’lari’ wortasi’nda wo’tkizilgen sorawda, 180 woqi’wshi’ni’n’ 60 awi’ futbolg’a, 45 i gu’reske, 15 i shaxmatqa, 30 i gimnastikag’a, qalg’anlari’ bolsa volleybolg’aqi’zi’g’i’wi’ ani’qlandi’. Bul mag’liwmatlardan paydalani’p soraw na’tiyjeleri ko’rsetkishi do’n’gelekli diagrammasi’n du’zin’.



U'yde wori'nlantug'i'n ma'seleler



- 1188.** Klass woqi'wshi'lari' wortasi'nda wo'tkerilgen sorawda, 25 woqi'wshi'ni'n' 15 i jasi'l ren'di, 9 i' qi'zi'l ren'di, 5 i aq rren'di, 3 i ko'k ren'di, qalg'anlari' bolsa sari' ren'di xosh ko'riwi ani'qlandi'. Bul mag'li'wmatlardan paydalani'p, soraw na'tiyjelerin ko'rsetiwshi do'n'gelekli diagramma du'zin'.
- 1189.** Zavodning 1- bo'limida 270 ishchi, 2- bo'limida 360 ishchi, 3- bo'limida esa 180 ishchi ishlaydi. Bundan tashqari zavodda 90 kishidan iborat ma'muriyat xodimlari ham bor. Zavod xizmatchilari tarkibini doiraviy diagramma shaklida tasvirlang.



- 1190.** Fermer xojali'g'i'ni'n' 22,4 ga maydani'ndag'i' i'ssi'xanada yeginler qanday maydanda yegilgenligi do'n'gelek diagrammada berilgen (5-su'wret). Ha'r bir yegin yegilgen maydanni'n' shamas'i'n' gektarlarda ani'qlan'.

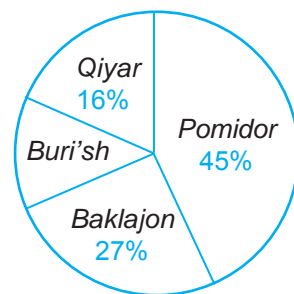

5- su'wret

- 1191.** Soraw natiyjelerine qarag'anda klastag'i' 36 woqi'wshi'ni'n' 6 awi' – a'debiyat, 8 i – matematika, 4 i – fizika, 3 i – ximiya, 7 si – ingilis tili, 6 si' – informatika ha'm 2 yewi ekonomika pa'ni boyi'nsha du'zilgen do'gereklerde shug'i'llanadi'. Bul mag'liwmatlar tiykari'nda bul klass woqi'wshi'lri'nin' pa'n do'gereklerine qatnasi'wi'n an'lati'wshi' do'n'gelek diagrammani' du'zin.



- 1192.** Wo'spirimler ha'r ku'ni salmaqti'n' ha'r bir kilogrammi'na sa'ykes ra'wishte 2,5 g belok, 2,2 g may ha'm 10,3 g uglevodlar qabi'l yetiwi lazi'm. Salmag'i' 40 kg bolg'an woqi'wshilar h'ar ku'ni qanshadan belok, may ha'm uglevodlar qabi'llawi'n grammlarda yesaplan' ha'm do'n'gelek diagramma du'zin'. Diagrammag'a at qoyi'n'.

- 1193.** Ali'mlardi'n' shamalap yesaplawlari'na qarag'anda, adam ortasha 72 ji'lli'q wo'mirinin' 30 ji'lli'n – uyqi'g'a, 12 ji'lli'n – jumi'sqa, 10 ji'lli'n – televizor ko'riwi ha'm internettegi socialli'q tarmaqlarg'a, 6 ji'lli'n – u'y jumi'slari'na, 5 ji'lli'n – awqatlani'wg'a, 4 ji'lli'n – ta'lim ali'wg'a, 2 ji'lli'n – jolg'a, 3 ji'lli'n – wo'zine qarawg'a ha'm qalg'an wo'mirin – basqa jumi'slarg'a sari'plap ati'rg'an yeken. Bul mag'liwmatlar tiykari'nda do'n'gelek diagramma du'zin' ha'm bul ko'rsetkishlerge wo'z pikirin'izdi bayan yetin'. Siz ku'ndelik waqti'n'i'zdi' tuwri' bo'listirip ati'rsi'z ba?



51- §.

VIII BAPTI' TA'KIRARLAWG'A TIYISLI MA'SELELER

1194. Televizor menen videomagnitofon birgelikte 600 000 swm turadi'. Videomagnitofonni'n' bahasi' televizordi'n' bahasi'na qarg'anda 20% arzan. Televizor ha'm videomagnitofonni'n' bahasi'n tabi'n'.

1195. 1-su'wretegi AOB mu'yeshtin' gradus wo'lishemin tabi'n'.

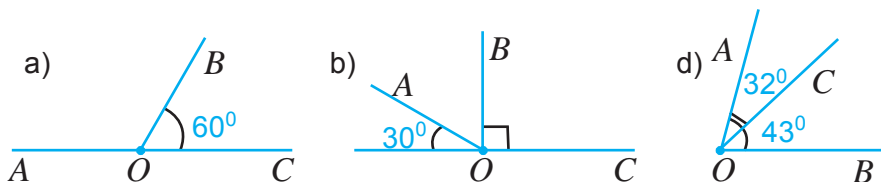

1196. Neftti qayta islegende: 30 % - benzin, 53 % - mazut ali'nadi'. Nefttin' qalg'an bo'legi bolsa, qayta islew bari'si'nda i'srap boladi'. a) neshe % neft i'srap boladi? b) 20 t neftten qansha benzin ha'm mazut ali'nadi'? d) 9 t benzin ali'w ushi'n qansha neftti qayta islew kerek?

1197 ABF jayi'q mu'yesh BC nur ja'rdeminde yeki mu'yeshke aji'rati'lg'an. ABC mu'yesh CBF mu'yeshten yeki ma'rte u'lken bolsa, bul mu'yeshtin' gradus wo'lishemin tabi'n'.

1198. Fermada bir ji'lida bir si'yi'r mayli'li'q da'rejesi 4 % bolg'an 12 500 litr su't beredi. Bul su'tten qansha may aji'rati'p ali'w mu'mkin?

1199. Ka'rxana jumi'sshi'lari'ni'n' dawalani'wi' ha'm dem ali'wi'na 24 500 000 swm pul aji'rati'ldi'. Bul puldi'n' 25 % dawalani'wg'a ketti. Ka'rxana ta'repinen jumi'sshi'lardi'n' dawalani'wi'na ha'm dem ali'wi'na qanshadan pul sari'plandi'?

1200. Avtobus 100 km arali'qqa 33 litr dizel jani'lg'i'si' sari'planadi'. Avtobusti'n' matori' won'lang'annan keyin jani'lg'i' sari'plani'wi' 10 % ke kemeydi. Avtobusti'n' matori' won'lang'annan keyin 100 kilometr arali'qqa qansha jani'lg'i' sari'playdi'?

1201. Su'ttin' 10 % maydan ibarat. 215 litr su'tten qansha may ali'wi' mu'mkin?

1202. Ta'relka kesedan 20 % arzan. Kese ta'relkadan neshe % qi'mbat?

1203. Jumi'sshi'ni'n' ayli'q is haqi' 300 000 swm boli'p, wol da'slep 10 % ke asti'. 6 aydan keyin ja'ne 20 % ke asti'. Jumi'sshi'ni'n' aqi'rg'i' is haqi' qansha?

1204. Saatti'n' saat tili a) 1 saatta; b) 2 saatta; d) 3 saatta; c) 4,5 saatta neshe gradusqa buriladi'?

1205. Dem ali'w lagerine jollanbani'n' bahasi' 340 000 swm. Ka'rxana jollanba bahasi'n 30 % tin to'lese jumi'sshi' 2 jollanba ushi'n qansha pul to'lewi kerek?

1206. $\angle ABC = 64^\circ$ boli'p, BD - woni'n' bissektrisasi. ABD mu'yeshti tabi'n'.

1207. G'ozani' tazalag'anda 60 procenti poshaqqa shi'g'i'p ketedi. Bahasi' 2000 swm bolg'an g'ozani' sati'p alg'an jasi'ma yamasa bahasi' 3500 swm bolg'an tazalang'an g'ozani' sati'p alg'an maqulma?



- 1208.** «DAMAZ» avtomashinasi' 100 km jolg'a 6 litr benzin sari'playdi'. Avtomashi'na 160 km jol ushi'n qasha benzin sari'playdi'?
- 1209.** Ji'yналg'an puldi' amanat bankine tapsi'ri'w mu'mkin. Sonda wol payda kel-tire baslaydi'. Yeger bank ji'li'na qoyi'lg'an puldi'n' 16 procenti mug'dari'nda u'steme payda beriwi belgili bolsa, tapsi'ri'lg'an 1 000 000 swm ji'l aqi'ri'n-da neshe swm boladi'? Yeki ji'ldan keyin ne?
- 1210.** Amanat bankine amanatshi' a swm tapsi'rди'. Yeger 1 ji'ldan keyin amanatshi'ni'n' yesabi'nda $\frac{5a}{4}$ swm bolg'an bolsa, amanatshi'ni'n' puli' neshe procentke asqan?
- 1211.** 1 t biydaydan 780 kg un, 25 kg usaq, 195 kg kepek ali'nadi'. Berilgen mag'li'uwmatlardan paydalani'p do'n'gelek diagramma du'zin.
- 1212.** Woqi'wshi'larg'a mo'lsherlengen noutbuk monitori'ni'n' wo'lshemi 10,1 dyuymg'a ten'. Monitor wo'lshemin santimetrlerde an'lati'n'.
- 1213.** Mektepler ushi'n mo'lsherlengen interaktiv doska monitori' diagonalini'n' wo'lshemi 87 dyuymg'a ten'. Monitor diagonalini'n' wo'lshemin santimetrlerde an'lati'n'.

Bilimin'izdi si'nap ko'rin'!



Bul bap materiallari'n u'yrenip shi'g'i'p, to'mendegi ma'selelerdi sheshe ali'wi'n'i'z sha'rt! Qadag'alaw jumi'si' aldi'nan wo'zin'izdi si'nap ko'rin'!

Test. Duri's juwapti' ani'qlan.

- Su'yir mu'yeshtin' gradus wo'lshemi haqqi'nda ne dew mu'mkin?
A. 90^0 qa ten'; || **B.** 90^0 tan u'lken; || **D.** 90^0 tan u'lken; || **E.** 180^0 qa ten'.
- a sani'ni'n' p % nege ten'?
A. $p : 100$; || **B.** $(a : 100) \cdot p$; || **D.** $p : a$; || **E.** $a : p$.
- Dog'al, tuwri', jayi'q ha'm su'yir mu'yeshlerden qaysi' biri kishi?
A. Dog'al mu'yesh; || **B.** Tuwri' mu'yesh; || **D.** Su'yir mu'yesh; || **E.** Jayi'q mu'yesh.

13- qadag'alaw jumi's u'lgisi

- Mu'yeshlerdi jasan': a) $\angle BME = 68^0$; b) $\angle CKP = 115^0$.
- $\angle A = 120^0$ bolg'an AKN u'shmu'yeshligin si'zi'n'. U'shmu'yeshliktin' qalg'an mu'yeshlerin wo'lshen' ha'm gradus wo'lshemlerin jazi'n'.
- OK nuri' DOS mu'yeshti 2 mu'yeshke bo'ledi. DOK mu'yeshi DOS mu'yeshinin 70 % quraydi'. KOS mu'yeshinin' gradus wo'lshemin tabi'n'.
- AMF jayi'q mu'yesh MC nur ja'rdeminde 2 mu'yeshke bo'lingen. AMC mu'yesh CMF mu'yeshinen 2 ma'rte u'lken bolsa, bul mu'yeshlernin' gradus wo'lshemin tabi'n'
- DKP jayi'q mu'yeshinin' KB bissektriysasi' ha'm KM nuri' ju'rgizilgen. Yeger $\angle BKM = 38^0$ bolsa, DKM mu'yeshin tabi'n'.

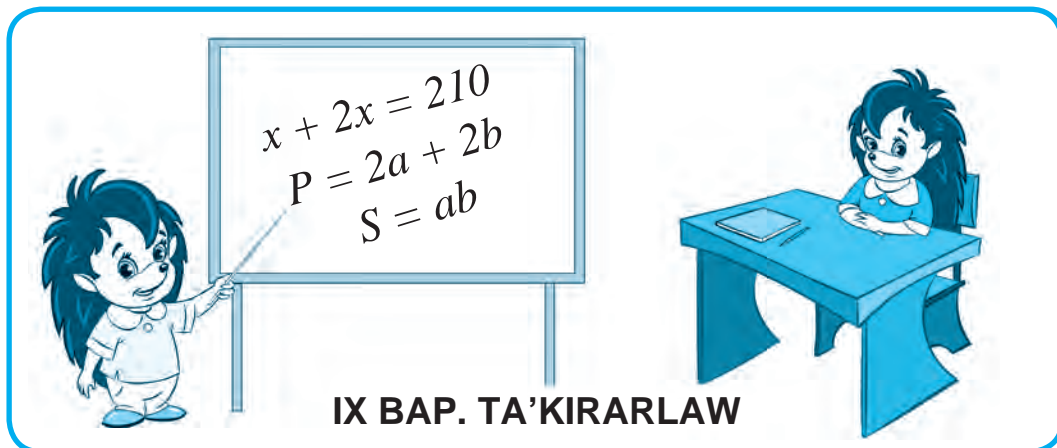

52- §.

V KLASTA WO'TILGENLERDI TA'KIRARLAWG'A TIYISLI MA'SELELER

- 1214.** Sanlardi' sali'sti'ri'n' ha'm juwapti' «<» yamasa «>» belgileri ja'rdemide jazi'n': a) 5 389 780 va 5 386 904; b) 103 636 va 94 577.
- 1215.** Sonlar nuridagi A, C, K, O noqatlardi'n' koordinatalari'n ani'qlan'.



- 1216.** Da'pter ketekshesinin' yenin birlik kesindi si'pati'nda ali'p, sanlar nuri'nda $A(3), E(13), M(7), P(10)$ noqatlari'n belgilen'.
- 1217.** a) 31 294 sani'nan 7546 g'a u'lken bolg'an sandi' tabi'n'?
 b) 63473 sani' 61625 sani'nan qansha u'lken?
 d) 63473 sani' 73251 sani'nan qansha kishi?
- 1218.** Birinshi qapta 46 kg kartoshka bar boli'p, bul yekinshi qaptagi'dan 15 kg kem. Yeki qapta barli'gi' boli'p qansha kartoshka bar?
- 1219.** DEF u'shmu'yeshliktin' EF ta'repi 53 sm. DF ta'repinen EF ta'repi 2 sm uzi'n, DE ta'repi bolsa 19 sm qi'sqa. U'shmu'yeshliktin' perimetrin tabi'n' ha'm woni' dm de an'alti'n'.
- 1220.** Tuwri' si'zi'qli' jol boylap 50 bag'ana wornati'ldi'. Bag'analar arasi'ndagi' arali'q birdey. Yeger yen' shettegi bag'analar arasi'ndagi' arali'q 2450 m bolsa, qon'si' bag'analar arasi'ndagi' arali'qti' tabi'n'.
- 1221.** An'latpani'n' ma'nisin tabi'n':
 a) $b + d$, bunda $b = 40, d = 50$; b) $450 + t - 350$, bunda $t = 84$.
- 1222.** Qolayli' usi'l menen yesaplan':
 a) $3817 + 2599 + 1183$; b) $759 - (259 + 413)$.
- 1223.** Uzi'nli'gi' 31 sm bolg'an MN kesindi de D ha'm E noqatlari' belgilendi. Yeger $MD = 15$ sm, $EN = 13$ sm bolsa, DE kesindi uzi'nli'gi'n tabi'n'.

- 1224.** A'mellerdi wori'nlan':
 a) $49 \cdot 176$; || b) $3800 \cdot 1570$; || d) $503 \cdot 705$; || e) $21\,645 : 185$; || f) $46\,970 : 154$.
- 1225.** Ten'lemeni sheshin':
 a) $x \cdot 17 = 119$; || b) $126 : y = 21$; || d) $a : 16 = 64$.
- 1226.** Qolayli' usi'l menen yesaplan':
 a) $25 \cdot 873 \cdot 4$; || b) $125 \cdot 794 \cdot 8$; || d) $20 \cdot 72 \cdot 50$.
- 1227.** Sa'lim bir sandi' woyladi'. Woni' 5 ke ko'beytip, ko'beymeden 9 di' aldi'. Na'tiyjede 71 payda boldi'. Sa'lim qanday sandi' woylag'an?
- 1228.** An'latpani'n' ma'nisin tabi'n':
 a) $583 \cdot 479 - 483 \cdot 479$; || b) $49 \cdot 68 - 7650 : 17 + 33$; || d) $4^3 + 7^2$.
- 1229.** Ten'lemeni sheshin': a) $6y - 25 = 617$; || b) $x + 7x = 104$.
- 1230.** An'latpani' a'piwaylasti'ri'n': a) $53t + 27 + 21t$; || b) $12 \cdot c \cdot 25$.
- 1231.** Yesaplan: a) $(4^3 + 14^2) : 13$; || b) $160 \cdot 76 - 56\,650 : 55 + 9571$.
- 1232.** Tuwri'mu'yeshlik formasi'ndagi' jer maydani'ni'n' uzi'nli'g'i' 540 m, yeni 250 m. Jer maydani'ni'n' maydani'n tabi'n' ha'm woni' ar da an'lati'n'.
- 1233.** Wo'lshemleri 4m, 5m ha'm 7 dm bolg'an tuwri'mu'yeshli parallelipipedtin' ko'lemin tabi'n'.
- 1234.** Tezligi 120 km/saat bolg'an tez ju'rer poezdin' to'rt saatta basi'p wo'tken joli'n tabi'n'.
- 1235.** 45 km/saat tezlik penen 270 km ju'zgen teploxodti'n' ju'ziw tezligin tabi'n'.
- 1236.** Qi'ri' 9 dm bolg'an kub betinin' maydani'n ha'm ko'lemin tabi'n'.
- 1237.** Sanlardi' sali'sti'ri'n':
 a) $\frac{6}{17}$ va $\frac{9}{17}$; || b) $\frac{11}{14}$ va $\frac{9}{14}$; || d) $\frac{8}{7}$ va 1; || e) $\frac{9}{10}$ va $\frac{7}{6}$.
- 1238.** 21 din' $\frac{3}{7}$ bo'legin 60 ti'n' $\frac{5}{6}$ bo'legine qosi'n'.
- 1239.** a) 3 sm^2 metr kvadratti'n' qanday bo'legin quraydi'?
 b) 37 mm^3 santimetr kubti'n' qanday bo'legin quraydi'?
 d) 17 kg^3 tonnani'n' qanday bo'legin quraydi'?
- 1240.** Tuwri'mu'yeshliktin' yeni 42 sm boli'p, wol perimetrinin' $\frac{3}{14}$ bo'legin quraydi'. Bul tuwri'mu'yeshliktin' uzi'nli'g'i'n tabi'n'.
- 1241.** A'mellerdi wori'nlan':
 a) $\frac{11}{17} - \frac{5}{17} + \frac{2}{17}$; || b) $6\frac{5}{8} + 2\frac{7}{8}$; || d) $8 - 4\frac{5}{7}$; || e) $7\frac{4}{15} - 3\frac{11}{15}$.
- 1242.** Quti'da 36 shar bar. Wolardi'n' $\frac{4}{9}$ bo'legi aq shar. Quti'da neshe aq shar bar?
- 1243.** Ten'lemeni sheshin': a) $6\frac{7}{9} - x = 4\frac{2}{9}$; b) $y + 2\frac{6}{7} = 5\frac{3}{7}$.

1262. BDM jayiq mu'yeshinin' DE bissektrisasi' ha'm DC nuri' ju'rgizilgen. Yeger $CDE = 19^\circ$ bolsa, BDC mu'yewshin tabi'n'.
1263. Tuwri'mu'yeshli parallelipeditin' ko'lemi $13,5 \text{ sm}^3$, yeni $4,5 \text{ sm}$, biyikligi 4 mm . Woni'n' uzi'ni'g'i'n tabi'n'.
1264. Matorli' qayi'qti'n' wo'z tezligi $12,6 \text{ km/saat}$, da'rya ag'i'mi'ni'n' tezligi bolsa $1,8 \text{ km/saat}$. Qayi'q ag'i'mg'a qarsi' $0,5 \text{ saat}$ ha'm ag'i'm boylap $2,5 \text{ saat}$ ju'zdi. Qayi'q bul waqit' ishinde qansha jol basi'p wo'tken?
1265. BCD ha'm DCE mu'yeshleri berilgen: $\angle BCD = 115^\circ$, $\angle DCE = 32^\circ$. $\angle BCE$ mu'yeshin tabi'n'.

Bilimin'izdi si'nap ko'rin'!



Bul bap materialлари'n u'yrenip shi'g'i'p, to'mendegi ma'selelerdi sheshe ali'wi'n'iz sha'rt! Qadag'alaw jumi'si' aldi'nan wo'zin'izdi si'nap ko'rin'!

Test. Duri's juwapti' ani'qlan'.

- $132\ 8\ 5\ 9 < 132 * 1\ 9$ ten'sizligin qanatlandi'ri'wshi' belgisiz c ifrdi' tabi'n'.
A. 7; B. 8; D. 9; E. 6.
- Si'zi'lmadag'i' A noqati'ni'n' koordinatasi' neshege ten'?



- A. 0,5; B. 1,25; D. 0,75; E. 0,25.
- ABC u'shmu'yeshliginin' ta'repleri 14 sm , 16 sm ha'm 19 sm . Woni'n' perimetrin tabi'n'?
A. 72 sm ; B. 22 sm ; D. 49 sm ; E. 52 sm .
 - Ten'lemeni sheshin': $y - 27 = 11 + 12$
A. 50; B. 38; D. 4; E. 12.
 - $4050 : \dots = 75$ ten'likte tu'sirilip qaldi'ri'lg'an san qaysi'?
A. 45; B. 33; D. 102; E. 54.
 - 3295 sani'n 73 ke bo'lse, qaldi'q ne boladi'?
A. 10; B. 27; D. 13; E. 35.
 - Tuwri'mu'yeshliktin' maydani' $97,5 \text{ sm}^2$, uzi'nli'g'i' 13 sm . Yenin tabi'n'.
A. $8,5 \text{ sm}$; B. $9,5 \text{ sm}$; D. $10,5 \text{ sm}$; E. $7,5 \text{ sm}$.
 - a ni'n' qanday ma'nisinde $\frac{a}{37}$ – duri's bo'lshek boladi'?
A. 38; B. 37; D. 36; E. 39.



Juwmaqlawshi' qadag'alaw jumi's u'lgisi

1. Yesaplan': $2,66 : 3,8 - 0,81 \cdot 0,12 + 0,0372$.
2. Du'kanda 240 kg miywe bar. Bir ku'nde woni'n' 65 procenti sati'ldi'. Qansha miywe qaldi'?
3. Tuwri'mu'yeshli parallelepipedtin' ko'lemi $25,2 \text{ dm}^3$, uzi'nli'g'i' $3,5 \text{ dm}$, yeni 16 sm . woni'n' biyikligin tabi'n'.
4. Teploxodti'n' wo'z tezligi $24,5 \text{ km/saat}$, da'rya ag'i'mi'ni'n' tezligi $1,3 \text{ km/saat}$. Teploxod aldi'n $0,4 \text{ saat}$ ko'l boylap, son' $3,5 \text{ saat}$ da'rya ag'i'mi'na qarsi' ju'zdi. Bul waqi't ishinde teploxod qansha jol basi'p wo'tken?
5. *MOK* ha'm *KOC* mu'yeshler berilgen: $\angle MOK = 110^0$, $\angle KOC = 46^0$. *COM* mu'yeshin tabi'n'.



Qi'ziqli' matematikag'a tiyisli ma'seleler

www.konkurs-kenguru.ru saytta matematikadan 2010-ji'lg'i' xali'q arali'q internet jari'si'ni'n' 5-klass woqi'wshi'lari' ushi'n berilgen ma'selelerden u'lg'i:

1. 2009-ji'l "Kenguru" jari'si'na du'nya boyi'nsha $5,5$ million bala qatnasti'. Wolardi'n ha'r biri 3 g bolg'an juwap betin toltirdi'. Barli'q juwap betlerinin' massasi'n tabi'n'.
2. Jirafani'n' uzi'nli'g'i' kengurudi'n' uzi'nli'g'i'nan $2,4$ ma'rte biyik, kengurudi'n' uzi'nli'g'i' bolsa jirafanikinen $2,52 \text{ m}$ pa's. Jirafa ha'm kengurudi'n' uzi'nli'g'i'n tabi'n'.
3. To'mendegi ten'likte \blacktriangle belgisi asti'nda qanday cifr jasi'ri'ng'an?
 $\blacktriangle + \blacktriangle + \blacktriangle + 6 = \blacktriangle + \blacktriangle + \blacktriangle + \blacktriangle + \blacktriangle + \blacktriangle$
4. $2010 : 10 + 2010 : 201 + 2010 \cdot 0$ an'latpada yeki qawsir'mani' sonday yetip qoyi'n' woni'n' ma'nisi yen' kishi bolsi'n.

Bul saytqa kirip, qalg'an ma'selelerdi sheship ko'rin'!

"Kenguru" xali'q arali'jari'sqa klasi'n'iz benen qatnasi'wdi' ma'sla'ha't beremiz.



J U W A P L A R I

- 1- §.** 2. a) 524; b) 602; d) 8 327; e) 1 923; f) 4 203; g) 6 340. 8. 3019 km. 11. 291 ta.
6. a) 53; b) 3 441; d) 12 030 085; e) 1 000 304 060; f) 430 090 000 000;
g) 650 500 203 007. 17. a) 157 999, 158 000, 158 001; b) 1 001 001, 1 001 000,
1 000 999. 27. 20 202, 202 020, 2 020 202.
- 2- §.** 35. 299 t. 38. a) 2 dm 3 sm; b) 6 dm 3 sm; d) 3 dm 9 sm; e) 21 dm 4 sm.
40. 1 100 swm; 1 400 swm. 41. 350 m. 49. 9 saat. 55. a) 43 sm 8 mm;
b) 90 sm 7 mm; d) 22 sm 3 mm; e) 76 sm 8 mm. 56. 135 sm. 57. 87 mm.
58. a) 72 sm; b) 12 dm; d) 131 mm.
- 3- §.** 63. a) kesispeydi; b) kesisedi; d) kesispeydi; e) kesispeydi; f) kesisedi;
g) kesisedi. 66. a) 2 m 2 dm 3 sm; b) 18 m 5 dm 2 sm; d) 5 dm 9 sm; e) 37 m 8 dm
3 sm. 69. 7. 70. 2 768 m.
- 4- §.** 74. a) 4; b) 50; d) 5. 76. a) 2; $A(2)$, $B(5)$, $C(8)$, $D(12)$, $E(13)$; b) 30; $A(60)$, $B(120)$,
 $C(210)$, $D(390)$. 88. a) $A(20)$, $B(40)$, $C(70)$, $D(130)$.
- 5- §.** 98. a) 19, 20, 21, 22, 23, 24, 25, 26; b) 2091, 2092, 2093, 2094. 101. 305.
103. a) $87^{***} > 86^{***}$; b) $5^{****} > 8^{**}$. 105. 123. 106. a) $456\ 500 > 49\ 900$;
b) $36\ 106 > 36\ 099$; d) $77\ 417 > 8\ 432$; e) $5\ 000 < 49\ 999$; f) $8\ 720\ 000 < 8\ 720\ 019$;
g) $930\ 000 < 1\ 000\ 001$. 108. $A(18)$; $B(47)$. 110. 450 km. 112. a) $8 < 10 < 23$;
b) $57 < 75 < 93$; d) $42 < 65 < 87$. 114. a) $600\ 080 < 609\ 900$; b) $43\ 006 < 43\ 007$;
d) $91\ 453 < 91\ 811$; e) $80\ 000 > 79\ 999$; f) $1\ 039\ 000 > 1\ 034\ 099$;
g) $5\ 000\ 009 < 5\ 000\ 010$. 115. 4 saat. 116. 5 saat. 118. $C(22)$; $D(34)$.
- 6- §.** 124. 203 sm. 125. 297 dm.
- 7- §.** 137. a) 57379; b) 149038; d) 28690; e) 30826; f) 114527; g) 1104233. 138. a) 9470; b) 3007;
d) 7842; e) 156739. 142. a) 42 193; b) 4 281 487; d) 730 243. 143. 487 t. 144. 35 063 km;
35 335 km; 36 034 km. 149. a) 155; b) 240; d) 1050; e) 490. 151. a) 50 104; b) 91 560;
d) 28 267; e) 42 805; f) 61 460; g) 46 193. 152. a) 1482; b) 3000; d) 1555; e) 952; f) 8824;
g) 41 668. 154. 34 kg 250 g. 156. 1088 t; 159. a) 436; b) 1170.
- 8- §.** 165. 99 550 swm. 169. 19 sm; 171. 355 ta. 172. a) 7642; b) 725; d) 974; e) 8001.
173. a) 4589; b) 6770; d) 3937; e) 8850. 182. 9 sm. 185. a) 8034; b) 30 576; d) 8011;
e) 32 024. 186. 774 m.
- 9- §.** 189. a) 97; 85; 69. b) 21; 106; 197. d) 35; 45; 135. e) 125; 15; 27. 190. a) 116;
118; 120. b) 5; 45; 65. 195. a) 16; 4; b) 30; 414. 196. a) 13; 15; b) 26; 39; 52.
198. $24 - m$; 18; 16.
- 10- §.** 201. a) $42 + m$; 45; b) $108 + y$; 120. 203. a) $22 - x$; b) $80 - x$; d) $y - 761$; e) $z - 531$.
206. $118 + x$; 130. 214. $56 - x$; 24.
- 11- §.** 217. a) 34; b) 870; d) 824; e) 4208; f) 373; g) 1186. 219. a) 17 kg; b) 24 kg. 222. 109 t.
232. a) 17; b) 2160; d) 91; e) 3726; f) 61; g) 1335. 240. a) 88; b) 85; d) 526; e) 1671.
243. 22 sm.

- 12-§. 245.** 359 kg. **251.** 11sm. **263.** a) 158; b) 457; d) 102; e) 333.
- 13-§. 272.** a) 959; b) 2916; d) 2986; e) 1133. **279.** 45 sm. **282.** 72 km. **283.** 3 saat. **289.** a) 2313; b) 4329; d) 1990; e) 2790. **294.** 81 mm. **296.** 510 ta.
- 14-§. 304.** a) 4051 ma'rte; b) 2205 ma'rte. **313.** a) 25; b) 102; d) 808; e) 1524. **314.** a) 828; b) 3080; d) 899; e) 592. **315.** a) 8; b) 21; d) 27; e) 112. **316.** a) 43; b) 41; d) 58; e) 132; f) 360088; g) 168640. **320.** a) 102 ma'rte; b) 214 ma'rte. **326.** a) 16; b) 55; d) 213; e) 3886; f) 44726; g) 89713. **327.** a) 15; b) 42; d) 151; e) 45; f) 56; g) 56291.
- 15-§. 334.** a) 781; b) 1092; d) 3718. **335.** 13 ta; 50 t. **341.** 100 g. **342.** a) 1752; b) 8218. **346.** 7 ta, 8 litr.
- 16-§. 358.** a) 1032; b) 4066. **360.** 75 sm; 120 sm. **362.** a) 1; b) 2; d) 7; e) 2. **366.** 4 kg. **368.** 25. **375.** 806 mm, 1550 mm. **378.** 420 t.
- 17-§. 390.** a) $9a + 936$; b) $41y + 1000$. **392.** A'li – 31 kg, Va'li – 30 kg, Sa'li – 26 kg. **398.** a) 184; b) 167; d) 1; e) 64; f) 602; g) 15609.
- 18-§. 410.** a) 13; b) 100; d) 9; e) 7; **416.** a) 4; b) 9; d) 5; e) 1. **422.** a) 4; b) 1; d) 8; e) 3.
- 19-§. 424.** a) 5411; b) 1263; d) 8125; e) 13672. **427.** 1047. **429.** 1046 mm. **431.** 1200 m, 125 ma'rte. **435.** a) 42; b) 123; d) 247; e) 37366; f) 207; g) 103. **444.** a) 4 kg; b) 5 kg.
- 20-§. 449.** a) 6 saat; b) 4 saat. **454.** 108000 km, 1800 km. **455.** 20 dm. **459.** a) 5 km/saat; b) 40 m/s. **461.** a) 536 dm; b) 72 dm.
- 21-§. 466.** a) 15 m^2 ; b) 144 dm^2 ; d) 516 sm^2 ; e) 6720 dm^2 . **471.** 748 sm^2 . **472.** a) 108 sm^2 ; b) 32 sm^2 ; d) 45 sm^2 . **475.** a) 15 dm^2 ; b) 18 dm^2 . **477.** a) 54 m^2 ; b) 1056 dm^2 ; d) 264 dm^2 ; e) 2695 m^2 . **481.** a) 140 dm^2 ; b) 150 sm^2 ; d) $ab - cd$.
- 22-§. 485.** 20 ar. **490.** 54675 sm^2 . **493.** a) 2800 m^2 ; b) 2800 m^2 . **494.** a) $ab : 2$; b) 25 sm^2 ; d) 20 sm^2 . **496.** 419528 sm^2 . **497.** a) 6 sm^2 ; b) 1500 sm^2 .
- 23-§. 503.** 296 sm. **507.** 1428 dm^2 . **509.** a) 2 ta – 2000 sm^2 , 2 ta – 1500 sm^2 , 1 ta – 1800 sm^2 . Jami: 10800 sm^2 ; b) 2 ta – 2000 sm^2 , 2 ta – 1500 sm^2 , 1 ta – 1200 sm^2 . Jami: 8200 sm^2 . **515.** 2268 g. **517.** 200 sm. **521.** 104 g.
- 24-§. 523.** a) 1440 sm^2 ; b) 1944 dm^2 ; **526.** 11 m. **531.** 62 kg 400 g. **532.** 16 kun. **533.** a) 72 litr, b) 48 litr. **535.** a) 320 dm^3 ; 308 dm^2 ; b) 534 dm^3 ; 279 dm^2 ; d) 156 dm^3 ; 142 dm^2 . **541.** 195 kg. **543.** 2268 g.
- 25-§. 547.** 124 dm; 961 dm^2 . **555.** 56 ar. **557.** 212 sm. **560.** 324 g. **562.** 468 kg. **564.** 19278 g. **565.** 8000 ta.
- 26-§. 570.** a) yaq; b) awa; d) awa.
- 27-§. 584.** a) $\frac{114}{513}$; b) $\frac{1012}{6223}$. **585.** a) $\frac{1}{7}$; b) $\frac{3}{7}$; d) $\frac{5}{7}$. **590.** 120 bet; 200 bet. **595.** a) 95; b) 845. **596.** a) $\frac{31}{56}$; b) $\frac{112}{259}$.
- 28-§. 603.** a) $\frac{5}{9} > \frac{4}{9}$; b) $\frac{1}{8} < \frac{7}{8}$; d) $\frac{2}{5} < \frac{3}{5}$; e) $\frac{2}{7} < \frac{6}{7}$. **605.** a) 525; b) 511; d) 51. **606.** $\frac{1}{12}$; $\frac{2}{12}$; $\frac{3}{12}$; $\frac{4}{12}$. **616.** 5, 6, 7, 8, 9; $\frac{5}{13}$; $\frac{6}{13}$; $\frac{7}{13}$; $\frac{8}{13}$; $\frac{9}{13}$.

- 29-§.** **621.** a) $\frac{4}{7}$; b) $\frac{7}{4}$. **622.** a) 1, 2, 3, 4, 5, 6, 7, 8, 9, 10, 11, 12; b) 1, 2, 3, 4, 5, 6, 7, 8, 9, 10, 11, 12, 13, 14, 15. **623.** a) 24; b) 76; d) 36; e) 75. **630.** 10 km. **633.** a) $\frac{4}{6}$; b) $\frac{6}{4}$. **635.** $\frac{7}{24}$. **637.** a) 36; b) 15.
- 30-§.** **640.** $\frac{13}{15}$ kg. **645.** a) 5; b) 12; d) 5; e) 9. **649.** 100 kg. **651.** 20 ga. **654.** a) $\frac{8}{34}$; b) $\frac{17}{77}$; d) $\frac{8}{24}$; e) $\frac{66}{87}$. **656.** 52 bet. **659.** $\frac{11}{12}$ kg. **664.** $\frac{14}{31}$. **666.** a) $\frac{25}{22}$; b) $\frac{20}{47}$; d) $\frac{61}{79}$. **667.** $\frac{2}{64}$. **671.** 6 oqi'wshi'.
- 31-§.** **679.** $\frac{2}{35}$ km. **682.** $\frac{19}{7}$ sm. **688.** $\frac{12}{25}$ km.
- 32-§.** **696.** a) $3\frac{5}{6}$; b) $3\frac{4}{11}$; d) $3\frac{16}{35}$; e) $2\frac{10}{23}$; f) $1\frac{97}{126}$. **698.** $\frac{13}{5}$; **704.** 39 ta. **709.** a) $\frac{29}{8}$; b) $\frac{22}{9}$; d) $\frac{317}{25}$; e) $\frac{1099}{87}$. **713.** $18\frac{1}{8}$ ta.
- 33-§.** **725.** $4\frac{2}{5}$ t. **731.** 20 sm. **737.** $22\frac{2}{11}$ dm; **749.** $11\frac{3}{8}$ t. **753.** $29\frac{8}{10}$ dm.
- 34-§.** **754.** 39 000 kg; 1250 kg; 9750 kg. **757.** a) $\frac{4}{6}$; b) $\frac{6}{4}$; d) $\frac{9}{4}$; e) $\frac{4}{9}$; f) $\frac{6}{9}$; g) $\frac{9}{6}$. **759.** 96 bet; 72 bet. **766.** 20 kun. **769.** $\frac{5}{7}$; 25 000 adam. **772.** a) $\frac{15}{17}$; b) $\frac{32}{71}$; d) $\frac{8}{27}$; e) $\frac{255}{583}$. **777.** $20\frac{2}{9}$ km/saat; $14\frac{6}{9}$ km/saat. **779.** $6\frac{3}{9}$ sm.
- 35-§.** **785.** a) 7,6; b) 7,318; d) 67,21; e) 34,3; f) 99,07; g) 3,3. **786.** a) $3\frac{14}{100}$; b) $10\frac{8}{10}$; d) $443\frac{91}{100}$; e) $7\frac{8}{1000}$; f) $\frac{91}{100}$; g) $\frac{3}{100}$. **790.** 1. a) 5,813kg; b) 0,457kg; d) 2,307kg; e) 7,097kg; f) 1,002kg; g) 14,835 kg. **794.** a) 3,4 m; b) 0,78 m; d) 3,01 m; e) 0,017 m; f) 43,01 m; g) 0,092 m; i) 0,409 m. **795.** $7,61\text{m}^2$; $6,33\text{m}^2$; $25,8\text{m}^2$; $32,01\text{m}^2$. **796.** 15 min; **797.** 668 000 swm, 691 500 swm, 612 000 swm.
- 36-§.** **816.** 2 saat.
- 37-§.** **825.** SAMARQAND. **828.** a) 7,9; b) 6,04; d) 11,9; e) 3,02. **830.** a) 0,469; b) 0,1063; d) 8,515; e) 4,1204; f) 22,307; g) 56,067. **833.** 177 km. **839.** 58,12 m.
- 38-§.** **846.** a) 0,4; 1,2; 0,9; 4,1. b) 0,73; 1,19; 2,68; 11,87; d) 2,901; 0,075; 4,28; 0,909; e) 3200; 176 100; 82 400; 10 000. **850.** a) 7137578000; b) 7138000000; d) 7000000000. **852.** a) 7; b) 12; d) 0; e) 9; f) 300; g) 7. **858.** a) 2; 1; 37; 802; b) 0,4; 0,8; 1,0; 61,4. **863.** a) 1 370 711 000; b) 1 371 000 000; d) 1 000 000 000.
- 39-§.** **874.** $110,8\text{ mi'n' km}^2$; $164,9\text{ mi'n' km}^2$. **877.** $26,5\text{ km/saat}$; $16,7\text{ km/saat}$. **884.** 6,566.
- 40-§.** **902.** $237,5\text{ km}$; 76 km. **905.** 8276 ts. **915.** 6,3 km.
- 41-§.** **923.** a) 1000 ma'rte; 100 ma'rte 10 ma'rte, b) 1000 ma'rte, 10 ma'rte, 10000 ma'rte, d) 10000 ma'rte, 10 ma'rte, 1000 ma'rte. **924.** a) 1,25 kg; b) 4,2 kg. **929.** a) 72 960 fut; b) 6671,52 m. **939.** a) 0,01; b) 0,77; d) 25,7; e) 0,6. **942.** 8,4 t; 8,4 t; 11,8 t.

- 42- §. 952.** a) 0,1968; b) 0,0525; d) 46,9625; e) 0,00322; f) 3,0366; g) 6,0398; h) 3,1632; i) 0,2256; j) 2,7217. **958.** $\approx 22,5 \text{ m}^2$. **961.** a) 105,939 g; b) 5,925 g. **967.** 9950 kg. **969.** a) 117,6 km. b) 172,84 km; d) 697,32 km; e) 1788 km. **974.** a) $31,8 \text{ sm}^2$; b) 68 sm^2 ; d) $21,36 \text{ m}^2$; e) $209,95 \text{ sm}^2$. **980.** 12880 swm. **984.** 153 080 swm. **988.** 375 m.
- 43- §. 998.** 120. **1002.** 4,5 qirotd. **1006.** 28,35 g. **1011.** 395 g. **1024.** 30,75 m; 154 ma'rite. **1025.** 5 ga.
- 44- §. 1033.** 2,2 m/s. **1035.** 24 ta. **1037.** a) 75,95; b) 0,7; d) 2,225. e) 6,7. **1038.** 10,1. **1043.** 381,5 t. **1044.** 768,75 km/saat. **1047.** 5. **1051.** 64 ta. **1052.** 3. **1053.** 4,96. **1056.** 11,84.
- 45- §. 1068.** 108 375 ts. **1080.** 5 litr. **1089.** 2454,8 kg.
- 46- §. 1099.** 448 899 mln km^2 . **1101.** 8,5 kg, 25,5 kg. **1107.** 30 622 058 kishi.
- 47- §. 1111.** 325 ga. **1114.** 960 m^2 . **1117.** 5000 swm. **1122.** 30%. **1128.** 75 000 ta. **1131.** 33 ta. **1135.** 3,28 kg; 5,87 kg.
- 48- §. 1146.** 15 min; 30 min. **1150.** *SOR, SOP* ha'm *ROP* mu'yeshler, 3.
- 49- §. 1160.** 84° . **1163.** 41° . **1164.** a) 40° . b) 60° . **1166.** 78° . **1173.** 20° . **1174.** 80° . **1176.** 45° .
- 50- §. 1181.** 0,7; 0,3. **1190.** Qiyar – 3,584 ga, pomidor – 10,08 ga, baklajon – 6,048 ga, buri'sh – 2,688 ga.
- 51- §. 1199.** 6 125 000 swm; 18 375 000 swm. **1202.** 25%. **1205.** 476 000 swm. **1208.** 9,6 litr. **1212.** 25,654 sm. **1213.** 220,98 sm.
- 52- §. 1217.** a) 38 840; b) 1848; d) 9778. **1220.** 50 m; **1223.** 3 sm. **1225.** a) 7; b) 6; d) 1024. **1229.** a) 107; b) 13. **1233.** $14\ 000 \text{ dm}^3$. **1238.** 59. **1239.** a) 0,0003; b) 0,037; d) 0,051. **1243.** a) $2\frac{5}{9}$; b) $2\frac{4}{7}$. **1254.** 48,4. **1256.** 2,06; **1259.** 17 km. **1263.** 7,5 sm.



Darslikni yaratishda foydalanilgan va ta'lim jarayonida foydalanish uchun tavsiya etilayotgan adabiyotlar va electron resurslar ro'yxati

1. A'zamov A., B. Haydarov. Matematika sayyorasi. Toshkent. «O'qituvchi», 1993.
2. M. A. Mirzaaxmedov, A. A. Raximqoriyev, 5- sinfdada matematika, o'qituvchilar uchun qo'llanma, Toshkent, «O'zbekiston ensiklopediyasi» 2007.
3. M. A. Mirzaaxmedov, A. A. Raximqoriyev, Matematika – 5, masalalar to'plami, Toshkent, «O'zbekiston ensiklopediyasi», 2007.
4. Saitov Yo. «Matematika va matematiklar haqida». Toshkent. «O'qituvchi», 1992.
5. Yosh matematik qomusiy lug'ati. Toshkent. «O'zbekiston ensiklopediyasi», 1991.
6. Кордемский Б. А. Математическая смекалка. Москва. «Наука», 1991.
7. Максимовская М. А. Тесты по математике 5–11 классы. Москва, «Олимп», 1999.
8. Кузнецова Л. В., Сафонова Н. В. Математика 5-класс, Тематические тесты, Москва, «Просвещение», 2010.
9. Г. В. Дорофеев и др., Математика 5-класс, Дедактические материалы, Москва, «Просвещение», 2010.
10. Г. В. Дорофеев и др. Математика 5-класс, Учебник, «Просвещение», 2010.
11. Е. А. Бунимов и др., Математика 5-класс, Рабочая тетрадь, Москва, «Просвещение», 2010.
12. И. Ф. Шарыгин. Задачи на смекалку, Москва, «Просвещение», 2010.
13. Л. Г. Петерсон, И. Г. Липатникова, Устные упражнения на уроках математики 5-класс, Москва, «Школа 2000», 2008.
14. Н. Я. Великин и др. Математика 5-класс, учебник, Москва, «Мнемозина», 2008.
15. М. А. Кубышева. Сборник самостоятельных и контрольных работ, Москва, «Школа 2000», 2008.
16. Э.Р.Нурк, А.Э.Тельгмаа, Математика – 5, учебник, Москва, «Просвещение», 1992.
17. М. А. Кубышева, Математика 5, Методические материалы, Москва, «Школа 2000..», 2006.
18. Г. В. Дорофеев, Л. Г. Петерсон, Математика – 5, учебник, Москва, «Ювента», 2010.
19. Roy Edwards, Mary Edwards, Alan Ward, «Cambridge mathematics» Module 5, 1-6 Books, Cambridge University press» 1998.
20. Roy Edwards, Mary Edwards, Alan Ward, «Cambridge mathematics» Module 6, 1-6 Books, Cambridge University press» 1998.
21. Johannes Paasonen «Ahaa matematiikkaa 5», Porvoo-Helsinki-Juva, 1993.
22. Nicole Pene, Philippe Deprasle «Decimale, Math 5», Belin, Paris, 1999
23. Jennie M. Bennett and others, «Pre-Algebra» Holt, Rinehart and Winston, New York, 2004
24. <http://www.edu.uz> - Xalq ta'limi vazirligining axborot ta'lim sayti (o'zbek, rus va ingliz tillarida).
25. <http://www.uzedu.uz> - Xalq ta'limi vazirligining axborot ta'lim portali (o'zbek, rus va ingliz tillarida).
26. <http://www.eduportal.uz> - Multimedia markazi axborot ta'lim portali (o'zbek, rus va ingliz tillarida).
27. <http://www.pedagog.uz> - malaka oshirish muassasalari sayti (o'zbek va rus tillarida).
28. <http://www.math5.zn.uz> - muallifning mazkur darslik bo'yicha ochiladigan maxsus sayti (o'zbek tilida).
29. <http://www.matematika.uz> - Masofadan turib o'qitish sayti (uzbek tilida).
30. <http://www.cde.sakha.ru> - Masofadan turib o'qitish sayti (rus tilida).
31. <http://www.iro.sakha.ru> - Ta'limni rivojlantirish instituti sayti (rus tilida).
32. <http://www.school.edu.ru> - Umumta'lim portali (rus tilida).
33. <http://www.allbest.ru> - Internet resurslari electron kutubxonasi (rus tilida).
34. <http://matematika.mgtdt.ru/> - Matematikadan va informatikadan sirtqi tanlov (rus tilida).
35. <http://www.mathtype.narod.ru/> - Online-darsliklar (rus tilida).
36. <http://mschool.kubsu.ru/> - Elektron qo'llanmalar kutubxonasi. Sirtqi matematik olimpiadalar.
37. <http://matematika.agava.ru/> - Matematikadan 2000 dan ortiq masalalar (rus tilida).
38. <http://mat-game.narod.ru/> - Matematik gimnastika. Matematik masalalar va boshqotirmalar.
39. <http://mathc.chat.ru/> - Matematik kaleydoskop (rus tilida).
40. <http://mathmag.spbu.ru/> - Internetdagi matematika jurnali (rus tilida).
41. <http://www.matematik1.narod.ru/> - Matematikadan masalalar (rus tilida).
42. <http://www.problems.ru/> Matematikadan masalalar izlash tizimi (rus tilida).

43. <http://geometry.net/> - Algebra va geometriyadan o'quv materiallari (ingliz tilida).
44. <http://mathproblem.narod.ru/> - Matematik to'garaklar, maktablar va olimpiadalar (rus tilida);
<http://www.pdmi.ras.ru/~olymp/> - Matematikadan olimpiada masalalari (rus tilida).
45. <http://mathtest.narod.ru/> - Matematik testlar (rus tilida).
46. <http://www.ams.org/mathweb/> - Internetda matematika (ingliz tilida).
47. <http://slovo.and.ru/z-index.htm> - Masalalar to'plami (rus tilida).
48. <http://www.sch57.msk.ru/collect/smogl.htm> - Matematika tarixiga doir sayt (rus tilida).
49. <http://www.mccme.ru/free-books/> - Matematikadan masalalar to'plami, ma'ruzalar, kitoblar (rus tilida).
50. <http://www.ixl.com> - Masofadan turib o'qitish sayti (ingliz tilida).
51. <http://www.konkurs-kenguru.ru> - Masofaviy matematik musobaqa sayti (rus tilida).
52. <http://www.cobo.uz> - Matematikadan tanlov (uzbek tilida).



BAHODIR HAYDAROV

«MATEMATIKA»

Umumiy o'rta ta'lim maktablarining 5-sinfi uchun darslik

Toshkent — «Yangiyo'l poligraf servis» — 2015

Muharrir — *J. Azimov*

Musahhih — *M. Riksiyeva*

Texnik muharrir — *M. Riksiyev*

Original-maketdan bosishga ruxsat etildi 25. 06. 2015.

Bichimi 70x100¹/₁₆. «Arial» garniturası. Ofset bosma usulda bosildi.
Shartli bosma tabog'i 17,55. Nashr bosma tabog'i 15,0. Nusxasi
Buyurtma N

Shartnoma N_____.

«Yangiyo'l poligraf servis» MCHJ bosmaxonasida bosildi.
Toshkent viloyati, Yangiyo'l tumani, Samarqand ko'chasi, 44.



Ijarag'a berilgen sabaqli'q jag'dayi'n ko'rsetetug'i'n keste

T/s	Woqiwshi'ni'n' ati', a'kesinin' ati'	Woqi'w ji'li'	Sabaqli'qti'n' ali'ng'an-dag'i' jag'dayi'	Klass basshi'-si'ni'n' qoli'	Sabaqli'qti'n' tapsi'ri'l-g'andag'i' jag'dayi'	Klass basshi'-si'ni'n' qoli'
1						
2						
3						
4						
5						
6						

Sabaqli'q ijarag'a berilip, woqi'w ji'li' aqi'ri'nda qaytari'p ali'nganda joqari'dag'i' keste klass basshi'si' ta'repinen to'mendegi bahalaw wo'lshemlerine tiykarlani'p to'lti'ri'ladi':

Jan'a	Sabaqli'qti'n birinshi ret paydalani'wg'a berilgendegi jag'dayi'.
Jaqsi'	Si'rti' putin, sabaqli'qti'n' tiykar'i' bo'liminen aji'ralmag'an. Barli'q betler bar, ji'rti'lmag'an , ko'shpegen, betlerinde jazi'w ha'm si'zi'qlar joq.
Qanaatlan-di'rarli'	Si'rti' ezilgen, birqansha si'zi'li'p, shetleri jedirilgen, sabaqli'qti'n' tiykar'i' bo'leginen aji'rali'w halati' bar, paydalani'wshi' ta'repinen qani'g'arli' du'zetiw islengen. Ko'shken betlerine qayta du'zetiw islegen, ayri'm betlerine si'zi'lg'an.
Qanaatlandi'rarsi'z	Si'rti'na si'zi'lg'an, asosiy qismdan ajralgan yoki butunlay yo'q, qoniqarsiz ta'mirlangan. Betlari yirtilgan, betleri jetispeydi, si'zi'p, boyap taslang'an. Sabaqli'qti' tiklep bolmaydi'.

