

MUSIQQA

2

Umumiy o'рта ta'lim maktablarining
2-sinfi uchun darslik

O'zbekiston Respublikasi Xalq ta'limi vazirligi
nashrga tavsiya etgan

Yangi nashr



TOSHKENT – 2021

UO'K 78(075.3)
KBK 74.268.53
N 25

Mualliflar:

**Nadim Norxo'jayev, Shoxista Norxo'jayeva,
Dilnoza Toshmuhamedova**

Taqrizchilar:

- M. Axmedov** – O'zbekiston davlat konservatoriyasi musiqa pedagogikasi kafedrasida mudiri, pedagogika fanlari nomzodi, dotsent.
- Z. Xodjaeva** – Andijon davlat universiteti musiqiy ta'lim kafedrasida katta o'qituvchisi.
- Z. Zakirova** – Toshkent shahridagi 17-sonli ixtisoslashtirilgan davlat umumta'lim maktabining musiqa madaniyati fani o'qituvchisi.
- T. Eshto'rayev** – Surxondaryo viloyat Muzrabot tumanidagi 14-umumiy o'rta ta'lim maktabining musiqa madaniyati fani o'qituvchisi.

SHARTLI BELGILAR:



– tinglaymiz



– kuylaymiz



– musiqa savodi



– mashq daftaringizda bajaring



– musiqa ijodkorligi



– dars yakuni



?! – mustahkamlash uchun topshiriq

Respublika maqsadli kitob jamg'armasi
mablag'lari hisobidan chop etildi.

Original maket va dizayn konsepsiyasi
Respublika ta'lim markazi tomonidan ishlandi.

ISBN 978-9943-7300-3-8

© Respublika ta'lim markazi, 2021

MUNDARIJA

Qadrli o'quvchilar!..... 5

1-BOB. KUY

Vatanimizni madh etamiz..... 6

“O‘zbekiston Respublikasi Davlat madhiyasi”.

A. Oripov she'ri, M. Burhonov musiqasi 7

“Aziz bo‘ston – O‘zbekiston”.

S. Mirzo she'ri, D. Omonullayeva musiqasi 8

Takrorlash 9

Kuy 10

“Maktabim”. *I. Muslimov she'ri, F. Nazarov musiqasi* 11

Takrorlash 13

Chorak nota 14

“Farg‘onacha”. *O‘zbek xalq kuyi*..... 15

“Boboq xo‘roz”. *P. Mo‘min she'ri, N. Norxo‘jayev musiqasi* 16

Qo‘shiq 18

“G‘ildiragim”. *T. Bahromov she'ri, Sh. Yormatov musiqasi*..... 18

“O‘ynaylik”. *A. Rahmat she'ri, II. Akbarov musiqasi*..... 19

Milliy cholg‘ular. *Nay* 21

“Quvnoq sayr”. *N. Norxo‘jayev musiqasi* 22

Tanbur..... 24

G‘ijjak..... 25

“Kayfiyat”. *N. Norxo‘jayev musiqasi*..... 26

“Uzum”. *P. Mo‘min she'ri, D. Omonullayeva musiqasi*..... 27

Nimchorak nota 28

2-BOB. YAKKANAVOZLIK VA JO‘RNAVOZLIK

Yakkanavozlik..... 30

“Asp bo‘laman”. *O‘zbek xalq kuyi*..... 31

“Qizaloq”. *T. Nazarov she'ri, N. Norxo‘jayev musiqasi* 32

Qomusimsan – faxrimsan..... 34

“Chamanda gul”. *O‘zbek xalq kuyi* 35

“Qadim Turon”. *P. Mo‘min she'ri, N. Norxo‘jayev musiqasi*..... 36

Jo‘rnnavozlik..... 38

“Yomg‘ir”. *T. Ubaydullo she'ri, N. Norxo‘jayev musiqasi* 39

Xonandalik va sozandalik 41

“Dangasa”.

M. Tojiboyev “Dugoh” maqomi ohanglari asosida yaratgan 42



“Archa bayrami”. <i>A. Rahmat she’ri, I. Akbarov</i> musiqasi	43
Notalarning guruhlanishi	44
Mustahkamlash uchun savol va topshiriqlar	45

3-BOB. MUSIQA SAVODIGA SAYOHAT

Takt va takt chizig’i	47
“Ot o’yini”. <i>D. Omonullayeva</i> musiqasi	48
“Bobom – qahramon”. <i>A. Haydarov she’ri va musiqasi</i>	49
O’lchov	50
Sanashni o’rganamiz	51
“Qashqarcha”. <i>O‘zbek xalq kuyi</i>	52
“Uxlab turdim”. <i>I. Muslim she’ri, F. Nazarov</i> musiqasi	53
Repriza	54
“Vals”. <i>P. Chaykovskiy</i> musiqasi, “ <i>Bolalar albomi</i> ”dan	55
“Navro‘zim – sho‘x sozim”. <i>H. Rahmat she’ri, N. Norxo‘jayev</i> musiqasi	56
Lad: major va minor	57
“Toreador marshi”. <i>J. Bize</i> musiqasi	59
“Zag‘izg‘on”. <i>P. Mo‘min she’ri, D. Omonullayeva</i> musiqasi	60
Musiqali rebuslar	61
“Yugurish”. <i>S. Abramova</i> musiqasi	62
“Ismaloq”. <i>P. Mo‘min she’ri, D. Omonullayeva</i> musiqasi	63

4-BOB. BOLALAR BASTAKOR VA KOMPOZITORLARI

Bastakor <i>Shermat Yormatov</i>	64
“O‘ynadik, hech to‘ymadik”. <i>P. Mo‘min she’ri, Sh. Yormatov</i> musiqasi	65
“Sog‘lom avlod qo‘shig‘i”. <i>T. Bahromov she’ri, Sh. Yormatov</i> musiqasi	66
Kompozitor <i>Nadim Norxo‘jayev</i>	67
“Chinnigul”. <i>Qambar Ota she’ri, N. Norxo‘jayev</i> musiqasi	68
“Hakkalar”. <i>N. Orifjonov she’ri, N. Norxo‘jayev</i> musiqasi	69
Kompozitor <i>Dilorom Omonullayeva</i>	71
“Qo‘g‘irchoqlar bilan raqs”. <i>D. Omonullayeva</i> musiqasi	72
“Buvijon”. <i>Y. Suyunov she’ri, D. Omonullayeva</i> musiqasi	73
Musiqqa ijodkorlari	74
“Kapalak va kamalak”. <i>N. Narzullayev she’ri, N. Norxo‘jayev</i> musiqasi	75
“Handalak”. <i>P. Mo‘min she’ri, D. Omonullayeva</i> musiqasi	76
Mustahkamlash uchun savol va topshiriqlar	77

QADRLI O'QUVCHILAR!

Musiqaning sehrlı olamıga sayohatımız davom etadi. Bu o'quv yilida sizni ko'plab yangi va qiziqarli ma'lumotlar kutib turibdi. Siz kuy, qo'shiq nima ekanini bilib olasiz, chorak va nimchorak notalar, musiqiy o'lchovlar haqida tushunchaga ega bo'lasiz. Tanbur, g'ijjak kabi milliy cholg'ularimiz jarangidan bahra olasiz. Bir qator musiqiy atamalar bilan tanishasiz va musiqani yaxshiroq tushuna boshlaysiz.

Ona Vatanimiz, go'zal tabiatimiz, do'stlik va tinchlik haqidagi ko'plab kuy va qo'shiqlarni tinglaysiz, kuylab o'rganasiz, ularga jo'r bo'lasiz. Bundan tashqari, fikrlash, o'ylab topish, ijod qilishga qaratilgan topshiriqlarni bajarasiz.



1–2-darslar

1-BOB
KUY

VATANIMIZNI MADH ETAMIZ

Madhiya – davlat ramzlaridan biri. Jonajon O‘zbekistonimizning ham o‘z madhiyasi bor. Unik turgan va o‘ng qo‘limizni ko‘ksimizga qo‘ygan holda ijro etamiz.



O'ZBEKISTON RESPUBLIKASI DAVLAT MADHIYASI



A. Oripov she'ri

M. Burhonov musiqasi

Serquyosh, hur o'lkam, elga baxt, najot,
Sen o'zing do'stlarga yo'ldosh, mehribon!
Yashnagay to abad ilm-u fan, ijod,
Shuhrating porlasin toki bor jahon!

N a q a r o t:

Oltin bu vodiylar – jon O'zbekiston,
Ajdodlar mardona ruhi senga yor!
Ulug' xalq qudrati jo'sh urgan zamon,
Olamni mahliyo aylagan diyor!

Bag'ri keng o'zbekning o'chmas iymoni,
Erkin, yosh avlodlar senga zo'r qanot!
Istiqlol mash'ali, tinchlik posboni,
Haqsevar ona yurt, mangu bo'l obod!

N a q a r o t:

Oltin bu vodiylar – jon O'zbekiston,
Ajdodlar mardona ruhi senga yor!
Ulug' xalq qudrati jo'sh urgan zamon,
Olamni mahliyo aylagan diyor!



O'zbekiston Respublikasi Davlat madhiyasi sizga qanday ta'sir qilgani, madhiyamiz qayerlarda va qanday tadbirlarda ijro etilishi to'g'risida so'zlab bering.





TAKRORLASH

NOTA YO'LI. NOTALARNING YOZILISHI VA NOMLANISHI

Musiqa tovushlari nota bilan yoziladi. Notalar yoziladigan beshta chiziqqa NOTA YO'LI deyiladi.

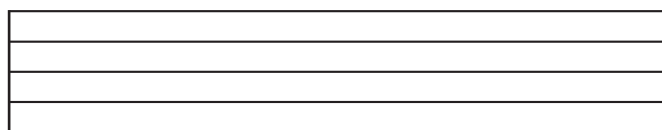

Nota yo'lining boshiga SKRIPKA KALITI qo'yiladi.

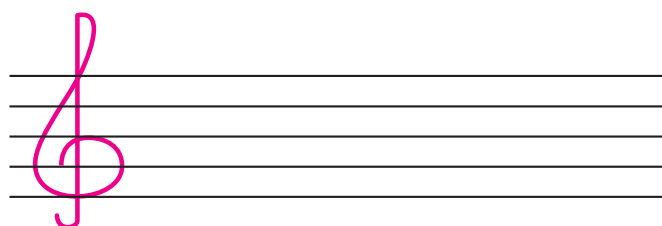

SKRIPKA KALITining aylana qismi nota yo'lining ikkinchi chizig'ini o'rab olgani va shu chiziqda sol notasi yozilgani bois bu kalit SOL KALITI deb ham ataladi.



Sol notasi

Musiqada yettita nota bo'lib, ular nota yo'lining beshta chizig'iga joylashadi va quyidagicha nomlanadi:

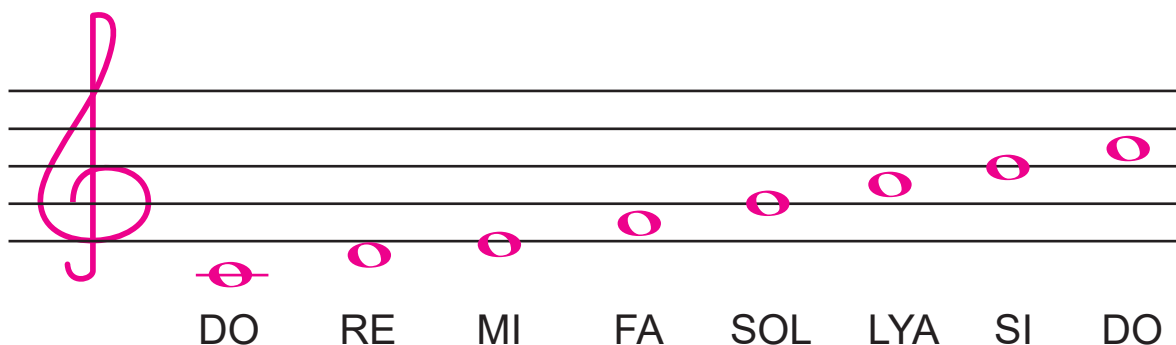

DO RE MI FA SOL LYA SI DO



3-dars

KUY

Kuy har qanday musiqaning asosidir. U turli balandlik va uzunlikdagi tovushlarning yig'indisidan hosil bo'ladi. Ohangdorlik kuyning asosiy xususiyatidir. Kuylar biror-bir cholg'u yoki ovozda ijro etiladi. Musiqada qo'shiq, raqs kuylari bor. Kuy yuqoriga, pastga tomon rivojlanishi mumkin.

QARI NAVO



DO'LONCHA



NEVARALAR QO'SHIG'I

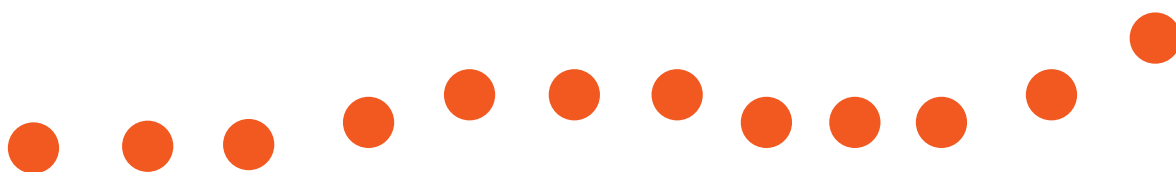

OQ LOLALAR



M. Leviyev musiqasi
 “*Mahallada duv-duv gap*” kinofilmidan



МАКТАБИМ



I. Muslimov she'ri

Ona kabi mehribon,
Ilm-fanlarga makon.
Yayrab o'qiyman har on,
Qadrdonim, maktabim!

Senda fanlar xilma-xil,
Ongim o'sar yilma-yil.
Sevinchlarga to'lar dil,
Qadrdonim, maktabim!

F. Nazarov musiqasi

Men dunyoda baxtiyor,
Hech chekmayman alam-zor,
Vatanim – mangu gulzor,
Qadrdonim, maktabim!

A'lo o'qishdir burchim,
Sarf etarman bor kuchim.
Ishlayman xalqim uchun,
Qadrdonim, maktabim!





O - na ka- bi meh - ri - bon, i- l(i)m, fan -lar- ga ma- kon.

Agar kuy harakatlanmaganida, uni qanday ijro etgan bo'lardik?

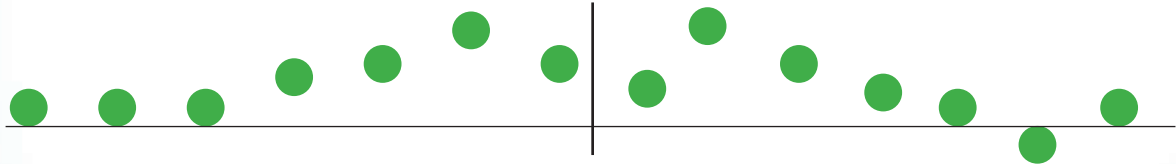

O - na ka- bi meh - ri - bon, i- l(i)m, fan -lar- ga ma- kon.

Qo'shiqning nota matniga qarab kuy qanday rivojlanganini aytib bering va uning harakatini ifodalang.

"Maktabim" qo'shig'ini cholg'u jo'rligida ifodali kuylang.

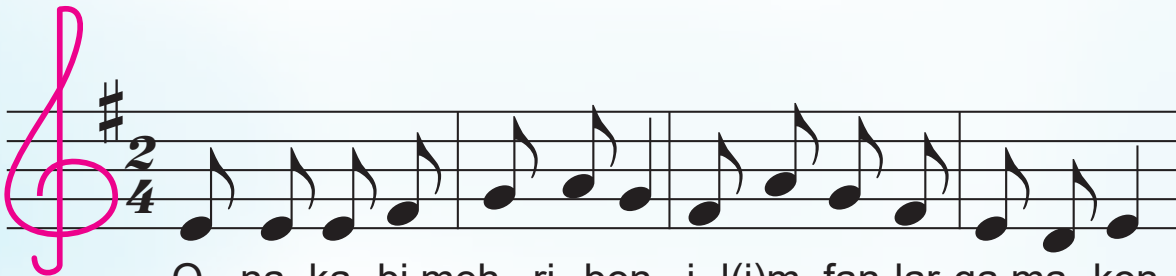

O - na ka- bi meh - ri - bon, i- l(i)m, fan-lar-ga ma- kon.

Qo'shiqning nota matnini yuqoridagi doirachalar bilan taqqoslang.

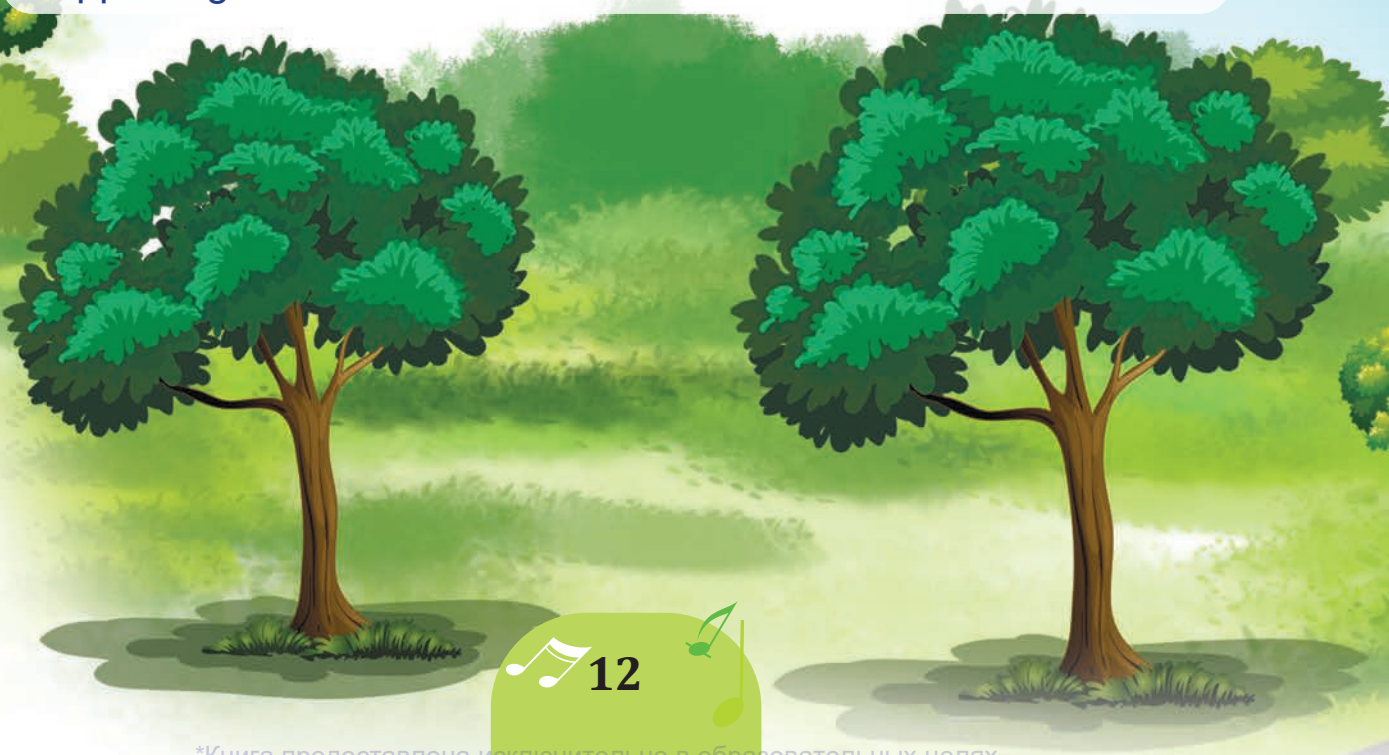

TAKRORLASH



BUTUN NOTA



Bilsang, butun notaman,
Har notadan kattaman.
Meni sanab "4 i" ga,
Keyin davom etasan.

YARIM NOTA



Men butunning yarmiman,
Yarimtalik notaman.
Sana meni "2 i" ga,
Bir quvonib ketaman.

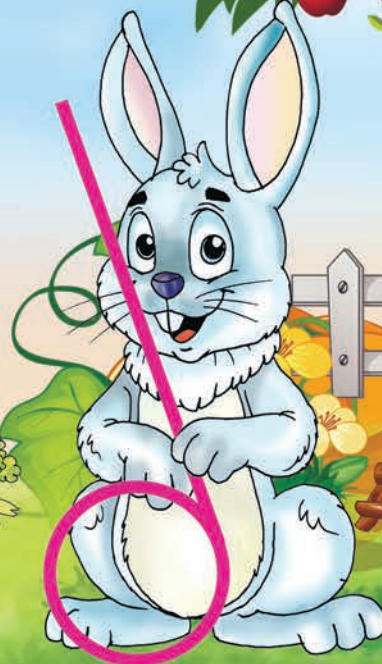
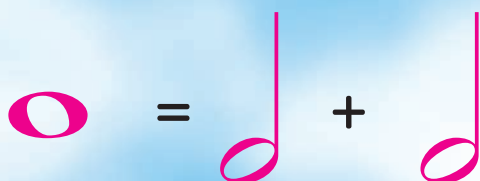

4-5-darslar

CHORAK NOTA

Bilsang, chorak notaman,
 Har qalay, kichkinaman.
 Qora xolday nuqtaman,
 Butun notada to'rttaman.

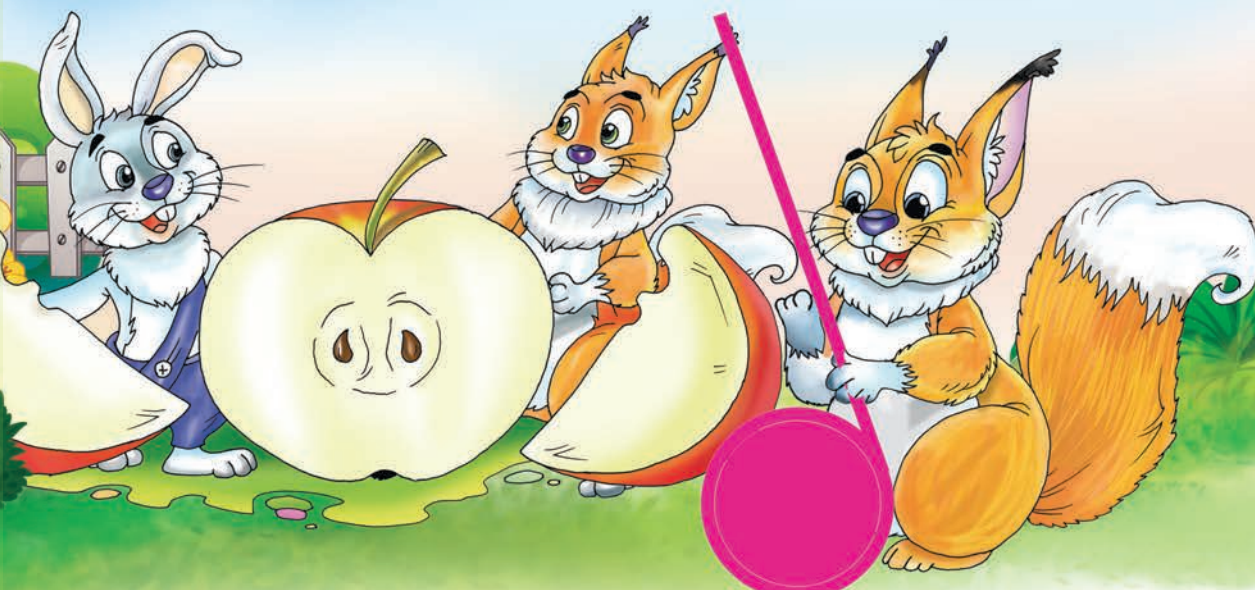
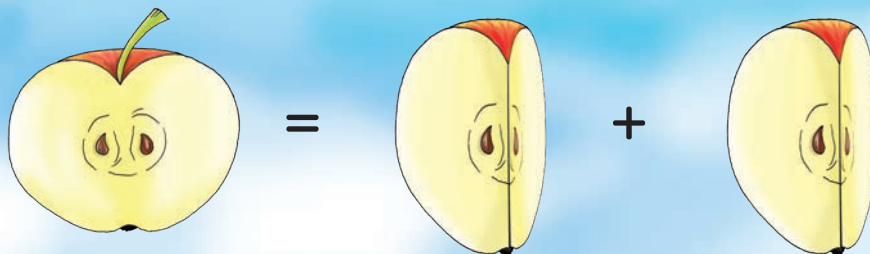

FARG'ONACHA

O'zbek xalq kuyi



Kuyning nota matnidan yarim va chorak notalarni toping.



BOBOQ XO'ROZ



P. Mo'min she'ri

N. Norxo'jayev musiqasi

Naqarot:

Boboq xo'roz, boboq xo'roz,
Toji qizil taroq xo'roz.

Dumi gajak, yurar sergak,
Xo'p kelishgan, bo'yi daroz,
Boboq xo'roz.

Naqarot.

Tumshuq artib saqlar tartib,
Qomatini tutadi g'oz,
Boboq xo'roz.

Naqarot.

Aybin lekin, aytay sekin:
Sal urishqoq, chatoq biroz,
Boboq xo'roz.

Naqarot.

Odamlarni, beg'amlarni
Uyg'otishi judayam soz,
Boboq xo'roz.

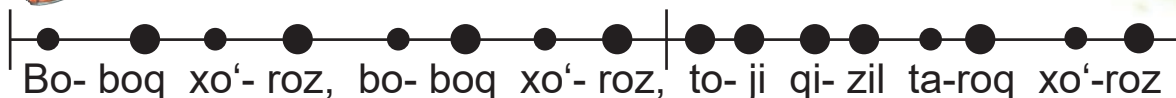

DO

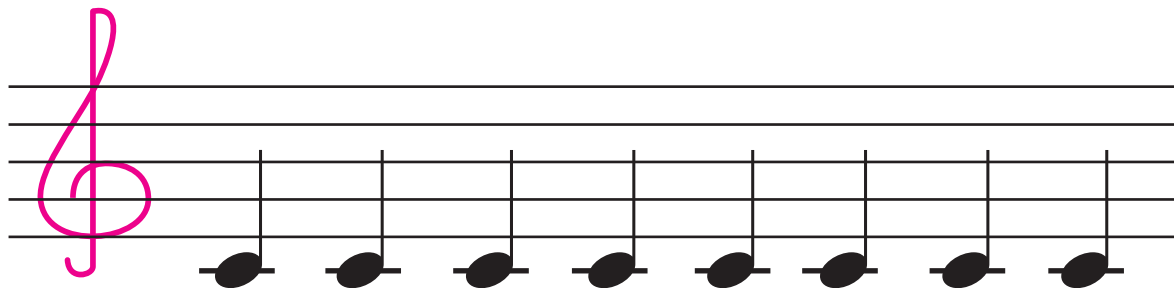
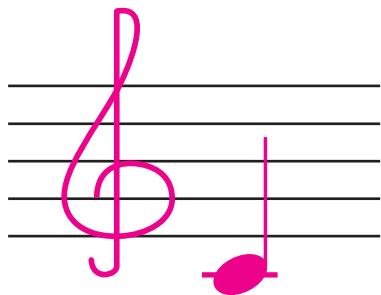

RE

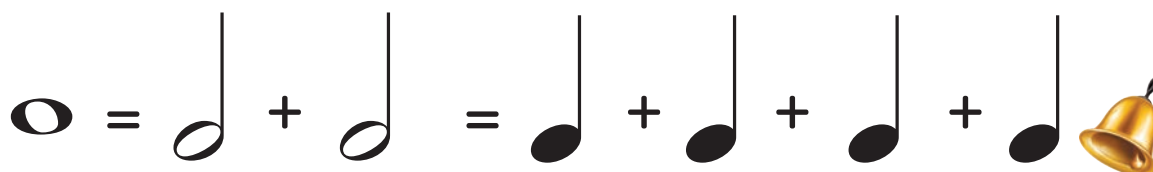
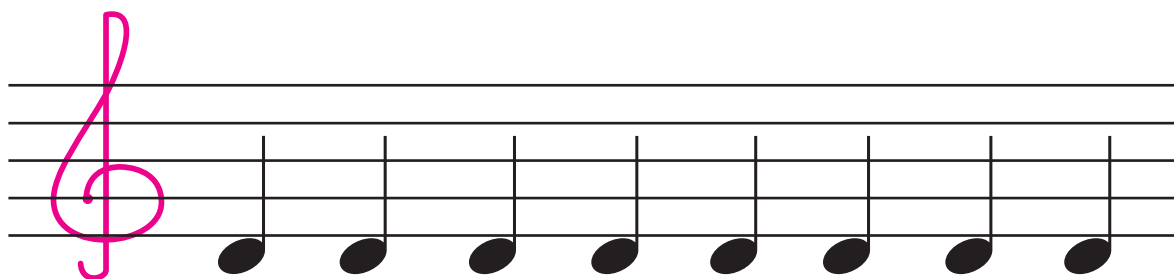
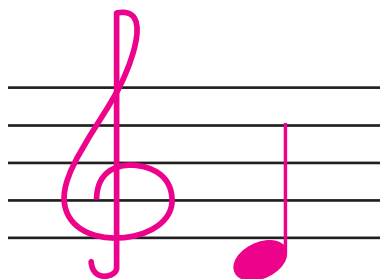

6-dars

QO'SHIQ

Qo'shiq she'riy matn va kuydan tashkil topadi. Cholg'u sozlari jo'rligida, ba'zan ular jo'rlogisiz ijro etiladi. Qo'shiq bir yoki bir nechta ijrochilar tomonidan aytilishi mumkin.



G'ILDIRAGIM

T. Bahromov she'ri

Sh. Yormatov musiqasi

Naqarot:

G'ildiragim, g'ildiragim,
Tezroq, tezroq pildiragin.

Ikkalamiz o'ynab-o'ynab,
Yuguraylik yo'lka bo'ylab.

Naqarot.

Uyga tomon ketaylik tez,
Eson-omon yetaylik tez.

Naqarot.

O'yinni men bas qilayin,
Damingni ol, dars qilayin.

Naqarot.



G'il-di-ra-gim, g'il-di-ra-gi -i - im, tezroq, tezroq pil- di- ra - gin.



A. Rahmat she'ri

O'YNAYLIK

II. Akbarov musiqasi



Do, re, mi, fa, sol, sol, sol
 Deb chertaman torimni,
 Soz bo'lganda jaranglab
 Kuyga solar barini.

Ulug' Vatan sha'niga
 To'qiladi kuylarim.
 Dutorim-la avj olar
 Mening shirin o'ylarim.



● ● ● ● ● ● ● ○ ● ● ● ● ● ● ● ○
 Do, re, mi, fa, sol, sol, sol deb cher-ta-man to-rim-ni.

Do, re, mi, fa, sol, sol, sol deb cher-ta-man to-rim-ni.

?!) Qo'shiqning doirachalar shaklidagi tovushlari uzun-qisqaligini nota matni bilan taqqoslang.





MI

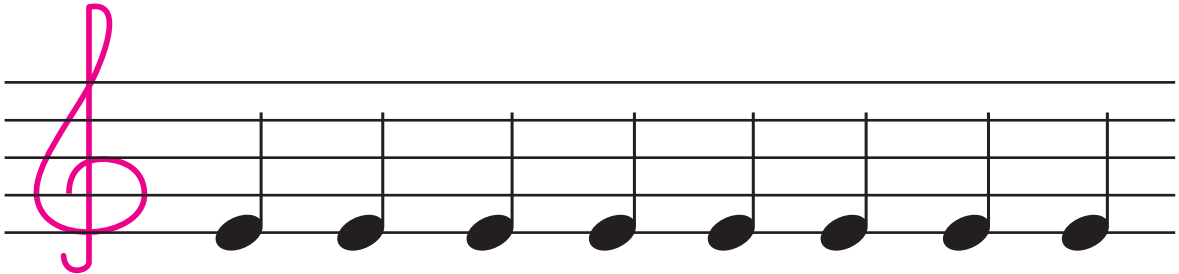
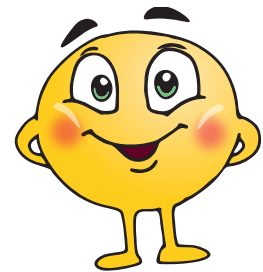
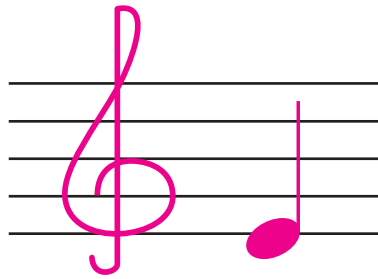

FA

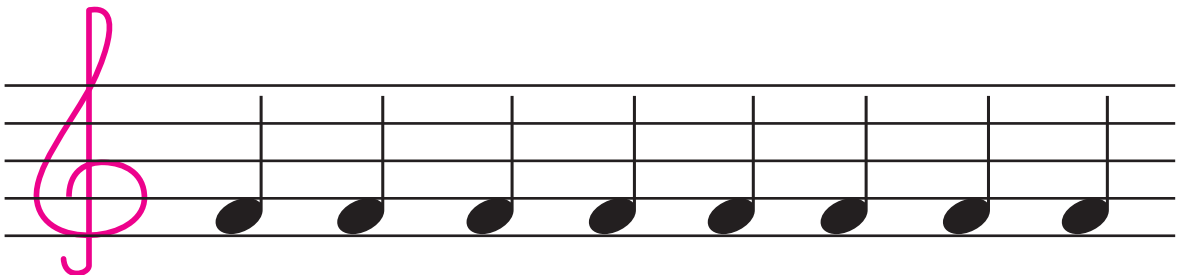
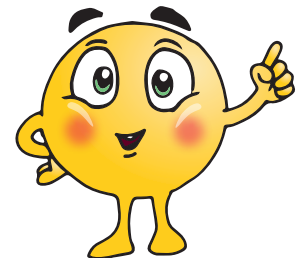
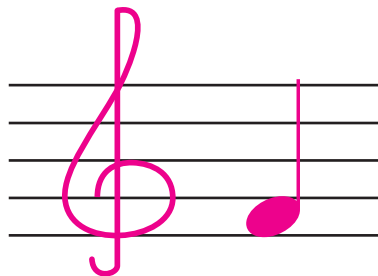

$\bigcirc = \text{note} + \text{note} + \text{note} + ?$



MILLIY CHOLG'ULAR

NAY

Nay – qamish va o'rik daraxtidan yasaladigan damli cholg'u. U asosan yonlamasiga ushlab chalinadi. Uning 6 ta asosiy, 2 ta tepa (orqa tarafida) va 1 ta pastda yordamchi teshikchalari bor. Nay damli o'zbek xalq cholg'ularidan biridir.

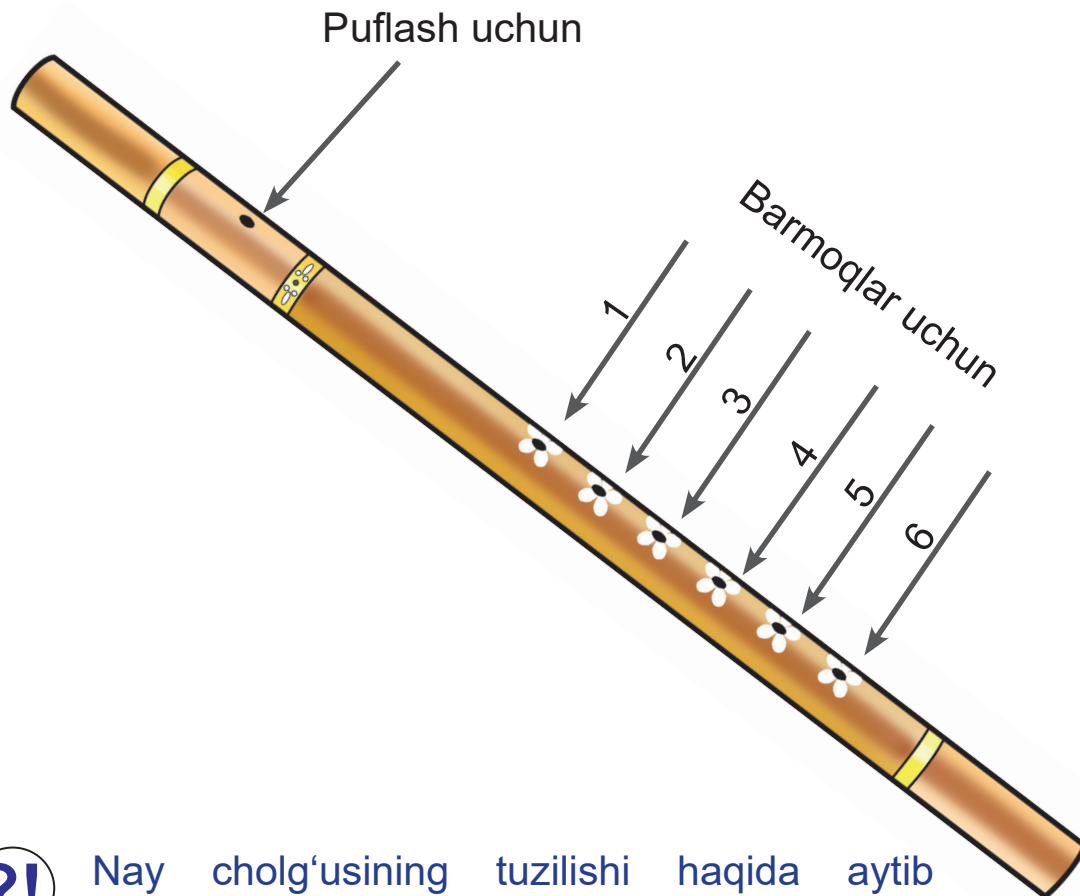

Nay cholg'usining tuzilishi haqida aytib bering. Nay ovozini tembridan farqlang.

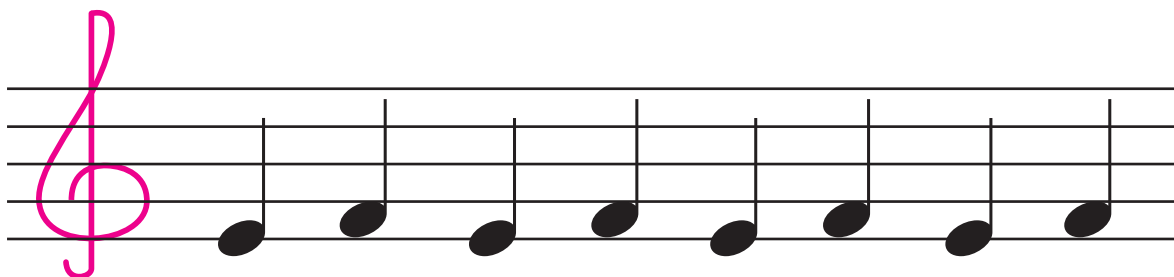

QUVNOQ SAYR

N. Norxo'jayev musiqasi

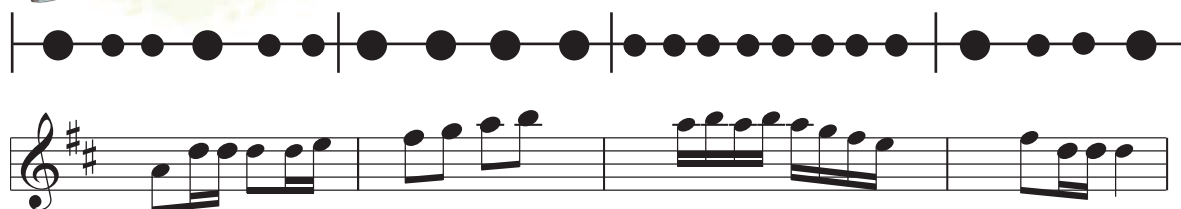

SOL



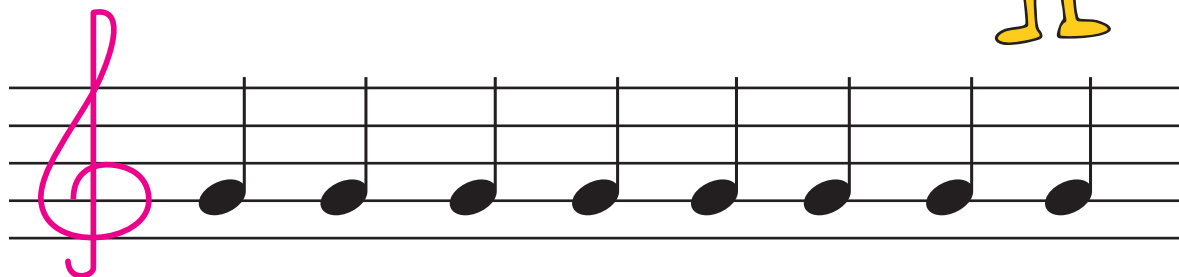

LYA



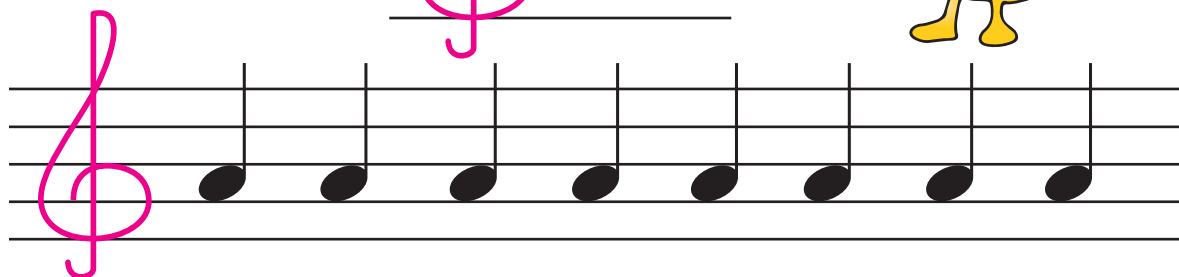

SI

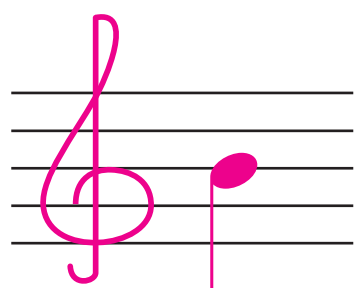
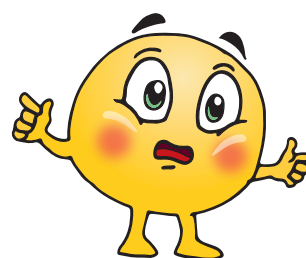





8–9-darslar

TANBUR

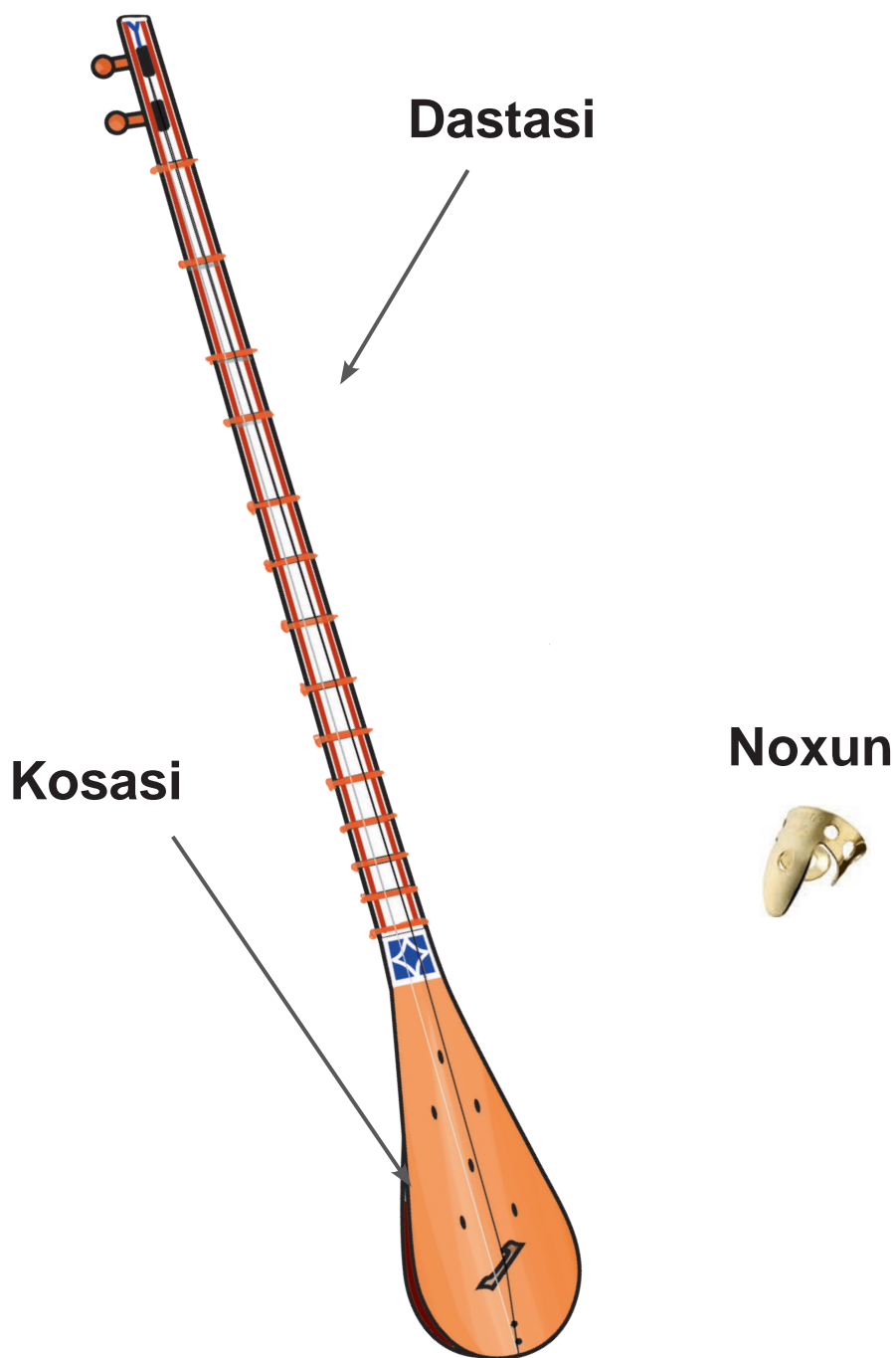
Tanbur – qadimiy tirnama o‘zbek xalq cholg‘usi. Tutdan yasaladi, barmoqlarga kiyilgan maxsus moslama – noxun yordamida tovush hosil qilinadi.



G'IJJAK

G'ijjak – qadimiy o'zbek xalq cholg'ularidan biri bo'lib, kamoncha bilan chalinadi.

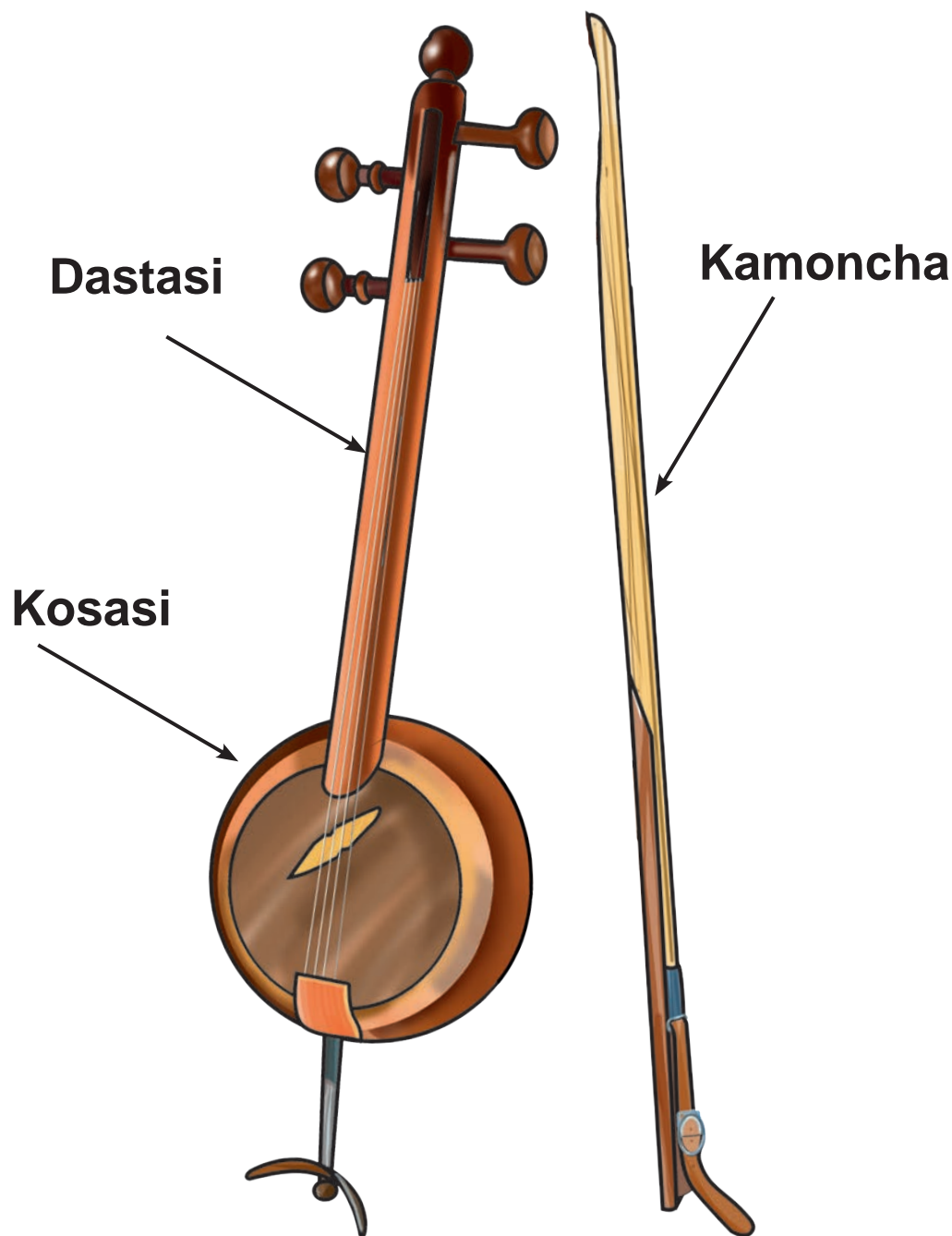

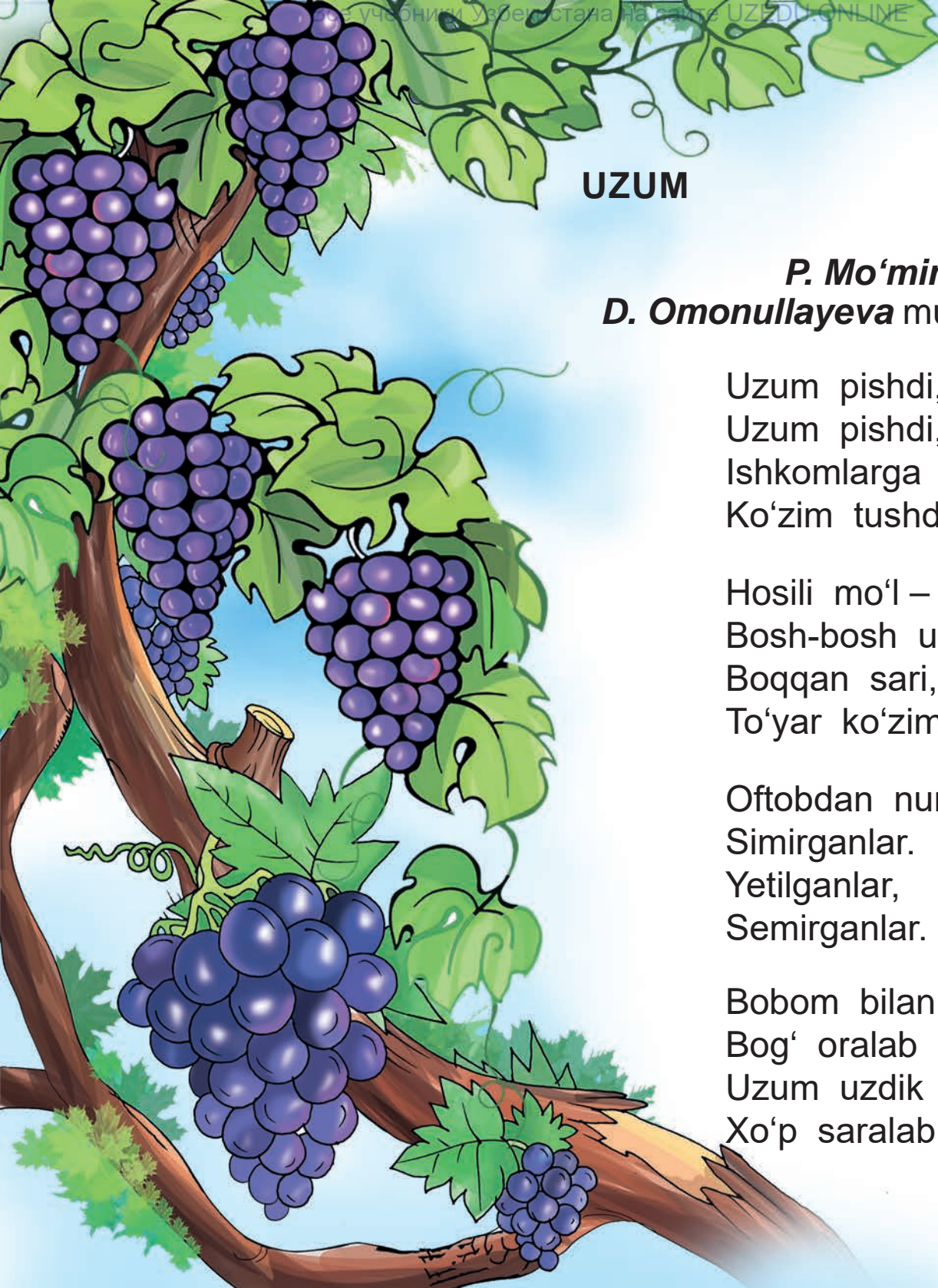

UZUM



P. Mo'min she'ri
D. Omonullayeva musiqasi

Uzum pishdi,
Uzum pishdi,
Ishkomlarga
Ko'zim tushdi.

Hosili mo'l –
Bosh-bosh uzum.
Boqqan sari,
To'yar ko'zim.

Oftobdan nur
Simirganlar.
Yetilganlar,
Semirganlar.

Bobom bilan
Bog' oralab
Uzum uzdik
Xo'p saralab.



Uzum pishdi, uzum pishdi, ish-kom-lar-ga ko'zim tushdi.



NIMCHORAK NOTA



Meni derlar “nimchorak”,
 Bayroqcham bundan darak.
 Qay asarda uchrasam,
 Meni tez kuylash kerak.

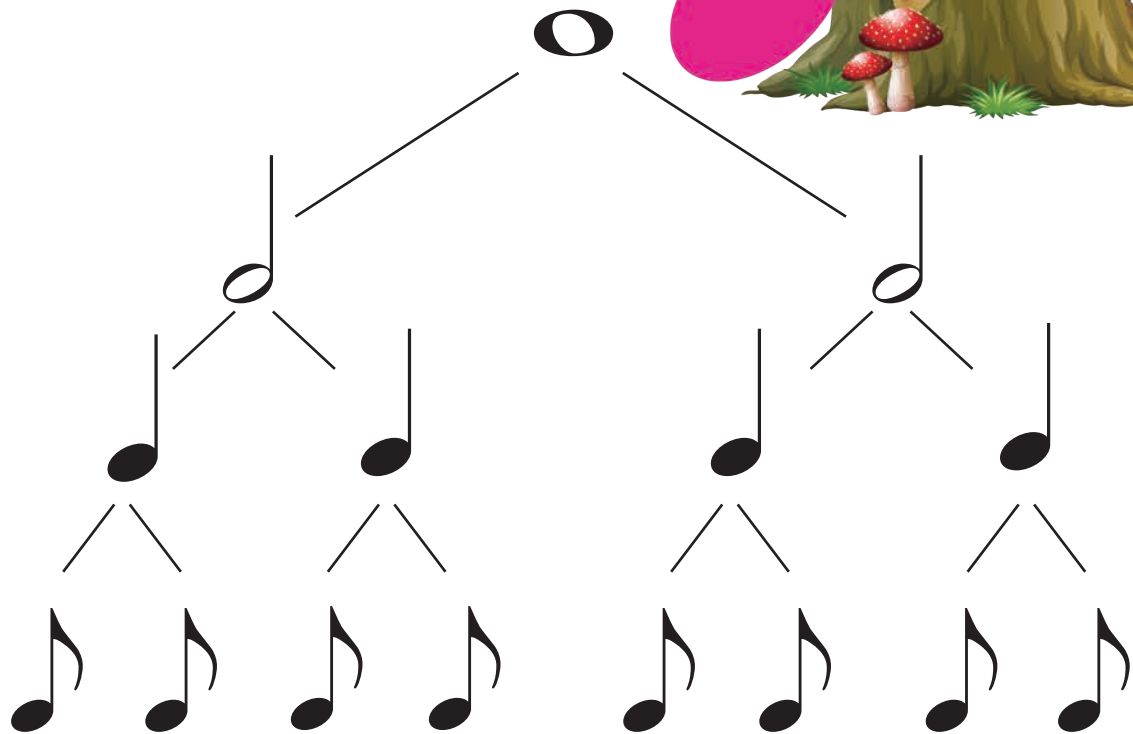
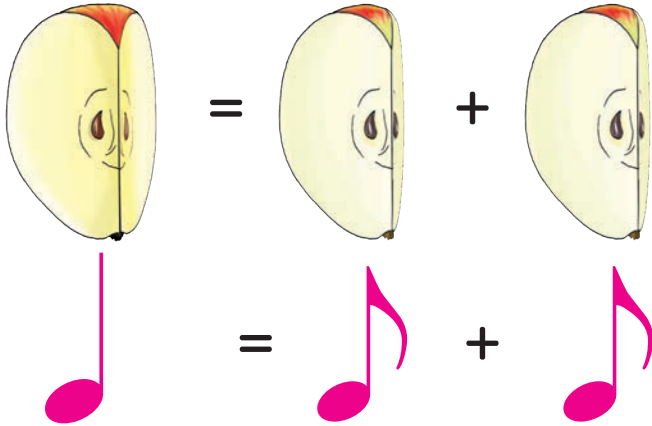

DO

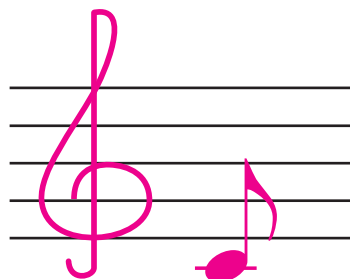

RE

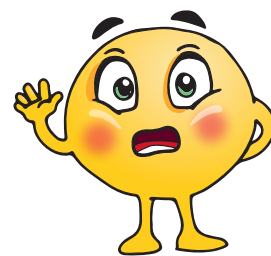
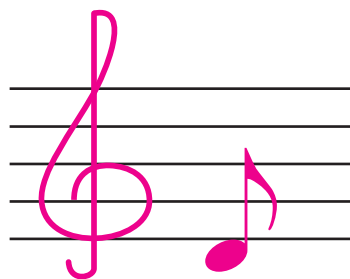

2-BOB YAKKANAVOZLIK VA JO'RNAVOZLIK

YAKKANAVOZLIK

Rasmdagi sozandaga qarang. U cholg'uda musiqiy asarni yakka o'zi ijro etyapti. Yakka holda ijro etish – **yakkanavozlik** deyiladi.





ASP BO'LAMAN

O'zbek xalq kuyi



The musical notation consists of two staves. The top staff is a rhythmic line with a series of black dots representing notes. The bottom staff is a standard musical staff with a treble clef, a key signature of one sharp (F#), and a 6/8 time signature. It contains a sequence of notes corresponding to the melody of the song.



Kuy harakatini mashq daftaringizda aks ettiring.



QIZALOQ



T. Nazarov she'ri

N. Norxo'jayev musiqasi

Yal-yal yonar yuzlaring
Misli lolaqizg'aldoq.
Yayrab, yayrab kulishing
Buncha shirin, qizaloq.

Oh, qizaloq, qizaloq,
Ikki ko'zi ko'zmunchoq.
Qiliqlaring chiroyli,
Lo'ppi yuzli bo'paloq.



Yal - yal yo - nar yuz - la - (a) - ring mis -
li lo - la qiz - g'al - doq.



Yal -yal yo-nar yuz-la- (a)- ring misli lo -la qiz - g'al-doq.



MI

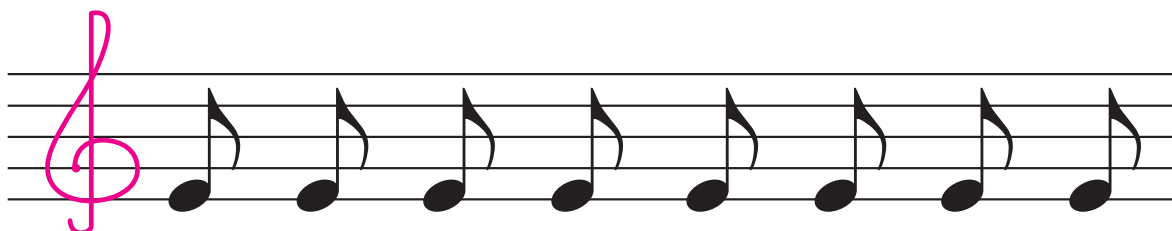
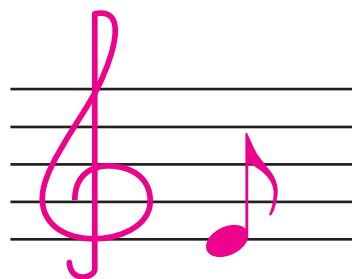

FA

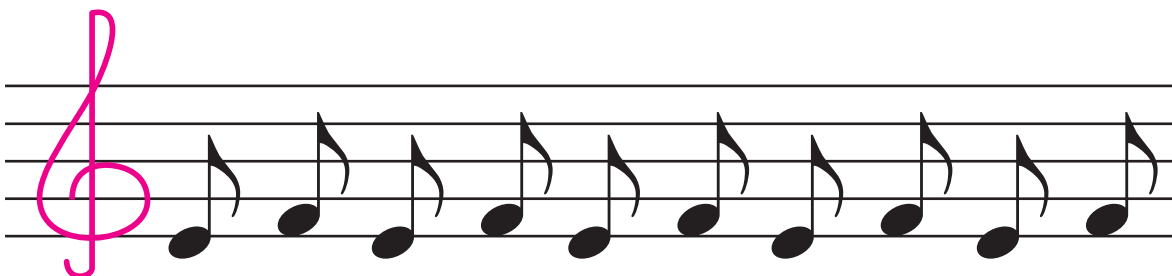
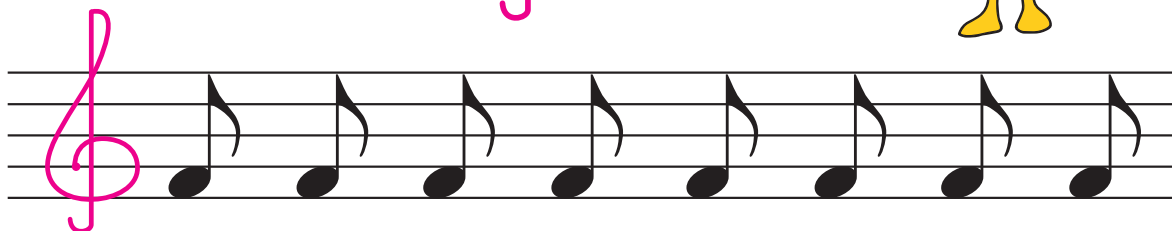
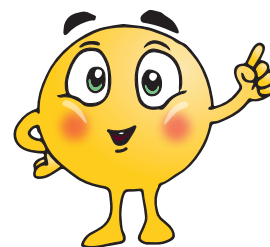
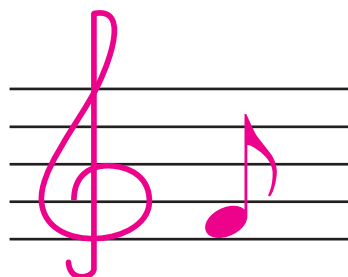

2–3-darslar

QOMUSIMSAN – FAXRIMSAN

Mamlakatimiz Konstitutsiyasi – davlatimizning bosh qomusi. Unda Vatanimizda yashayotgan insonlarning asosiy huquq, majburiyat va erkinliklari ifoda etilgan.



CHAMANDAGUL

O'zbek xalq kuyi

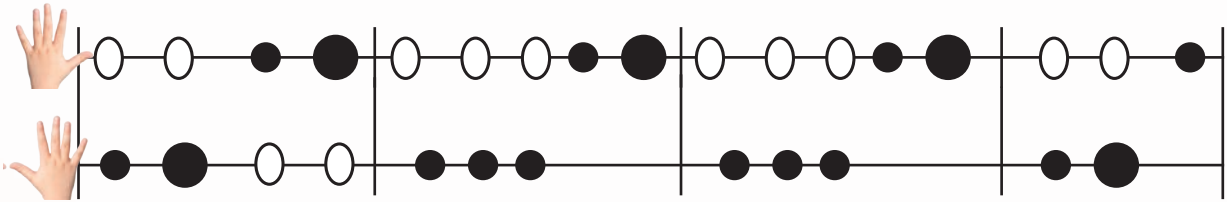

?! Ikki guruhga bo'linib ijro eting:

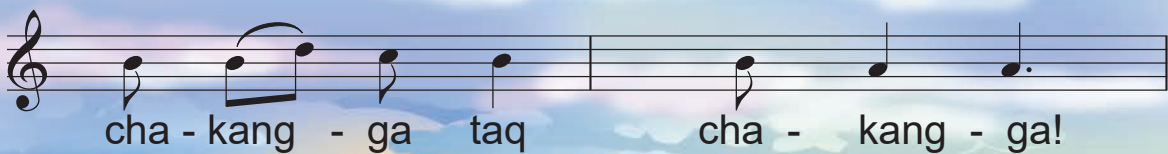
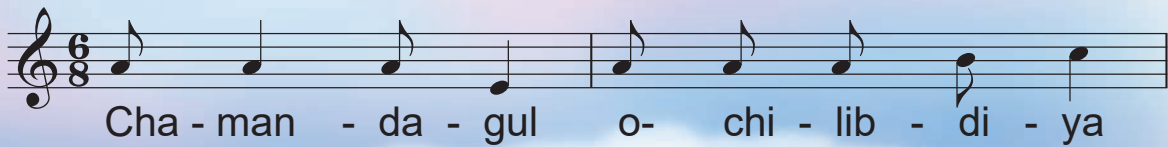
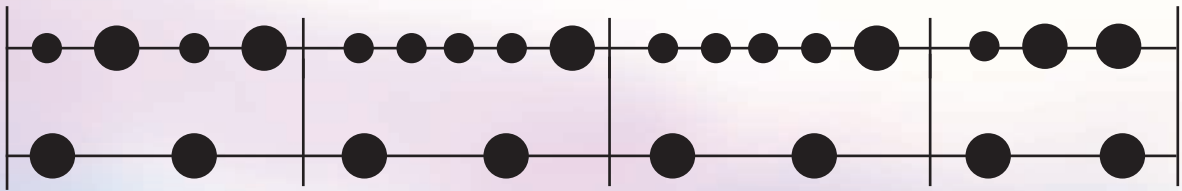

QADIM TURON



P. Mo'min she'ri

N. Norxo'jayev musiqasi

Uch, Humo qush,
Parvozi xush.
Osmonimda,
Makonimda.

Naqarot:

Keng Turkiston
Menga makon.
El – qadrdon,
O'zbekiston.

Samosi sof,
Chaqnar oftob.
Bag'ri kengdir,
Do'sti tengdir.

Naqarot.

Aytay chindan,
Baxtim sendan.
Sen doimo
Bor bo'l, Humo!

Naqarot.



SOL

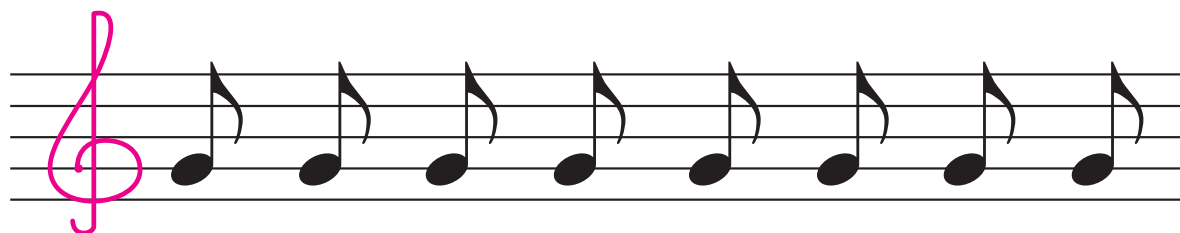
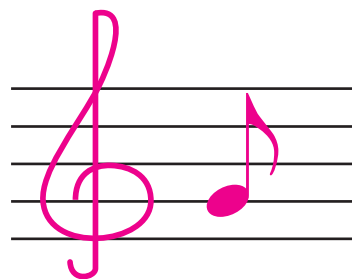

LYA

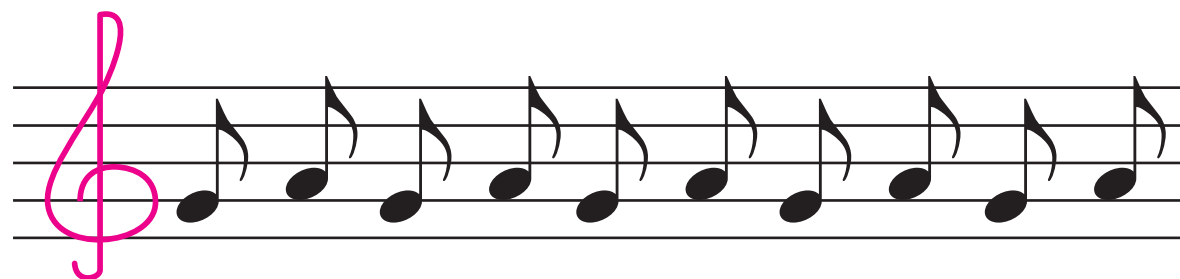
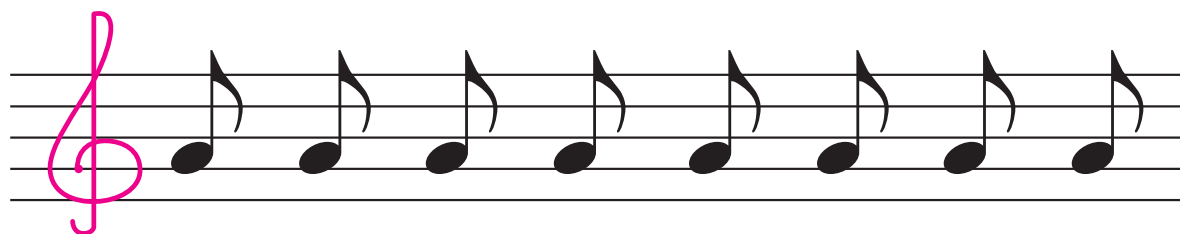
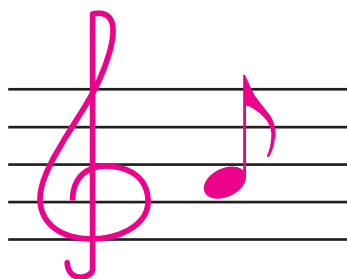

4–5-darslar

JO'RNAVOZLIK

Ikki cholg'u sozida birgalikda kuy ijro etilishiga jo'rnavezlik deyiladi. Jo'rnavezlar bir-birlarini tinglab, asar ijro etadilar.



?!) Yakkanavez va jo'rnavez ijrochilikda qanday farq hamda o'xshashlikni ko'ryapsiz?



YOMG'IR

T. Ubaydullo she'ri

N. Norxo'jayev musiqasi

Shivir-shivir shivirlab,
Yomg'ir yog'di shitirlab.
Bo'g'otlarga berkindi
Sho'x chumchuqlar pitirlab.

Naqarot:

O'ynab-o'ynab tushar suv,
Kuylab-kuylab tushar suv.
Yer bag'rini to'ldirib,
Quvnab-quvnab tushar suv.

Yomg'ir yog'ar paqirlab,
Chuchvarasi vaqirlab.
Har tomchi qut, baraka,
Yashnaydi dala, qirlar.

Naqarot.

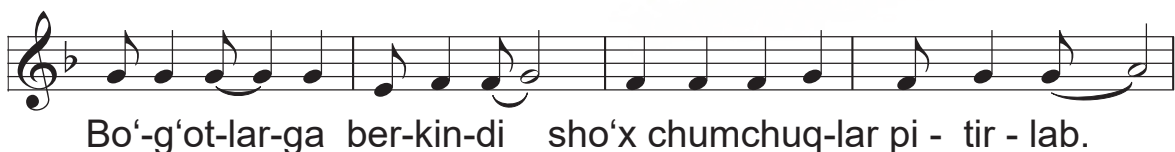
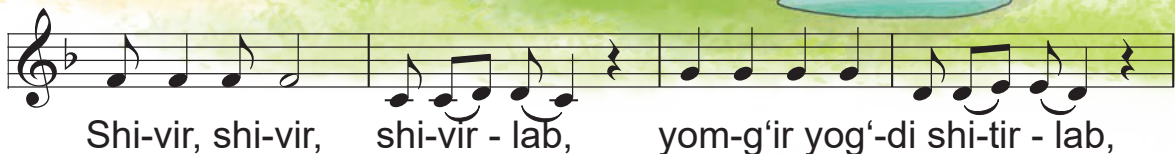



SI

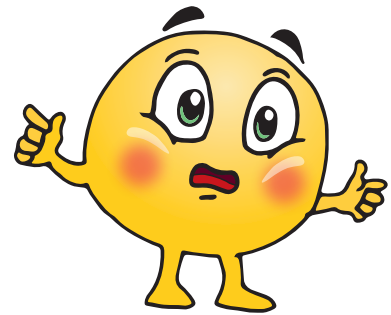
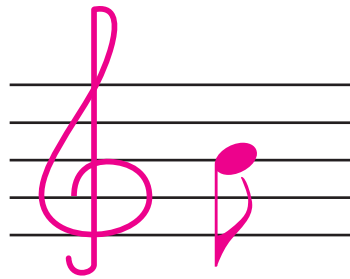

DO₂

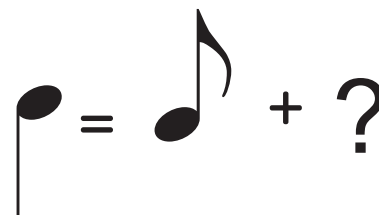
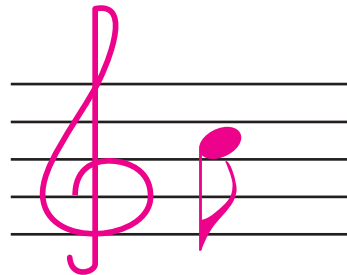

XONANDALIK VA SOZANDALIK

Xonandalik qo'shiq ijrochiligi bilan bog'liq musiqiy kasbdir. Xonandalar qo'shiqlarni ovozda, cholg'u jo'rligida yoki cholg'u jo'rligisiz ijro etadilar.

Sozandalik esa kuy ijrochiligi bilan bog'liq musiqiy kasbdir. Sozandalar kuylarni turli cholg'ularda ijro etadilar.



?!) Xonanda bilan sozanda ijrosini tinglab farqlang.



DANGASA

M. Tojiboyev “Dugoh” maqomi ohanglari asosida yaratgan

Dangasaning holi yomondir,
Dars qilgani qo‘li bormaydi.
Ketayotgani yomon tomondir,
Qo‘lin sovuq suvga urmaydi.
Dangasa bo‘lmang, dangasa,
G‘ayratli bo‘ling, g‘ayratli bo‘ling.



Dan - ga - sa bo‘l- mang, dan - ga - sa - a.

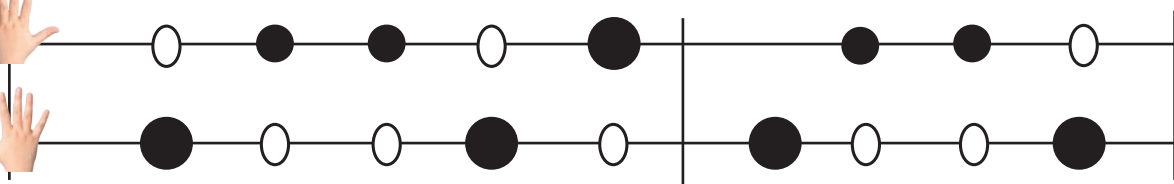

“Dangasa” qo‘shig‘i ritmini nota matni bilan taqqoslang.

ARCHA BAYRAMI

A. Rahmat she'ri

I. Akbarov musiqasi

Shamol oppoq qorlarni
 Quvib-quvib xo'p yeldi.
 Bizga uzoq o'rmondan
 Archa mehmonga keldi.

Qorbobomiz ko'p yaxshi,
 Bizga sovg'a keltirar.
 Chiroqlarning nurida
 O'yinchoqlar yaltirar.



NOTALARNING GURUHLANISHI

Nota yozuvida nimchorak notalarni yozish qulay bo'lishi uchun ular bitta chiziq bilan birlashtiriladi. Nimchorak notalar ikkitadan, ayrim hollarda to'rttadan birlashadi. Buning uchun ularning bayroqchalari bir biriga ulanadi.



Berilgan mashqdagi chorak notalarni “bak”, nimchorak notalarni esa “bum” bo'g'inlari bilan aytib, jo'r bo'lamiz:

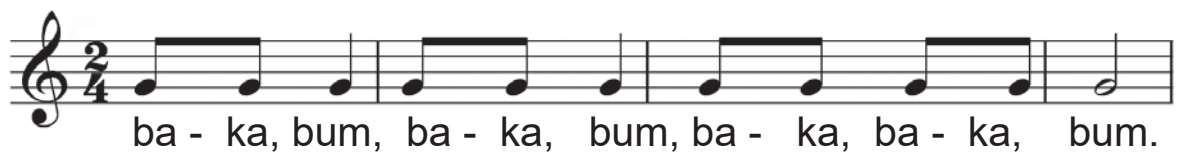
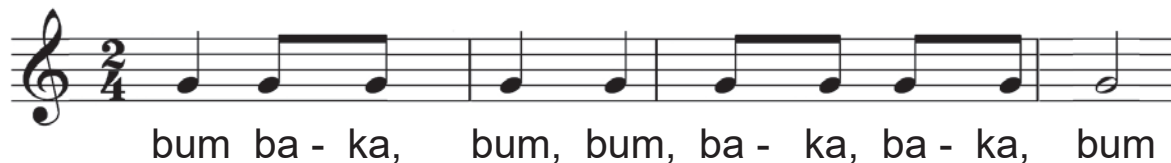



8. Bulardan qaysi biri tanbur?



9. Tanbur bilan g'ijak o'rtasida qanday farq bor?

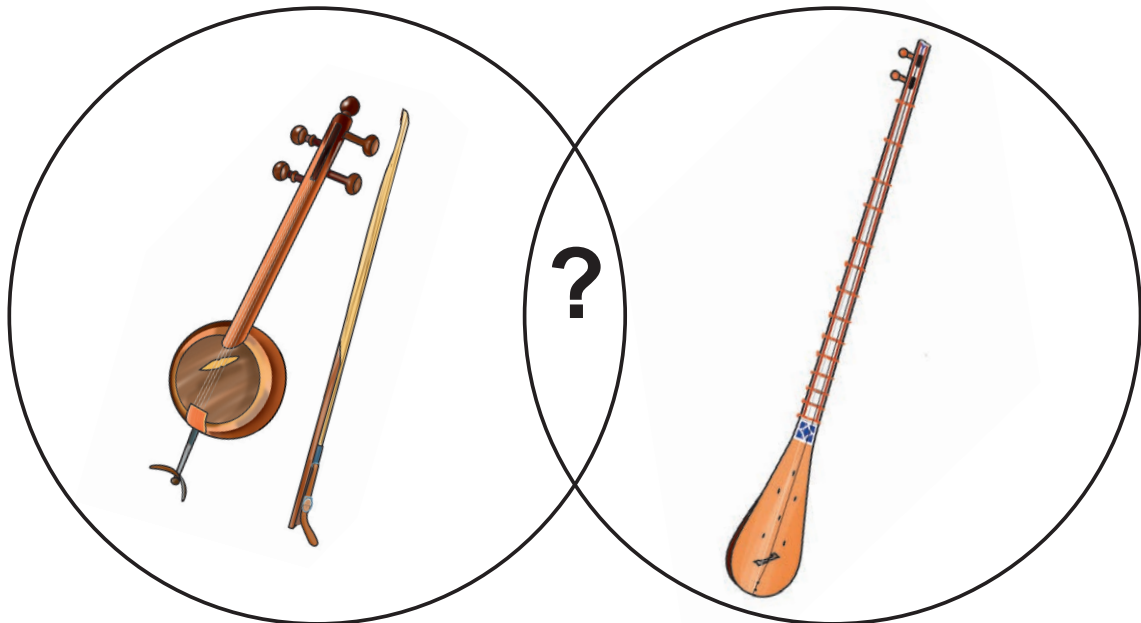

10. Bulardan qaysi biri "Dangasa" kuyining ifodasi?





3-BOB MUSIQA SAVODIGA SAYOHAT

TAKT VA TAKT CHIZIG'I

Kuy taktlarga bo'linadi.



Takt kuchli va kuchsiz hissalaridan tashkil topadi.

Kuchli hissa oldidan tikka chiziq qo'yiladi.

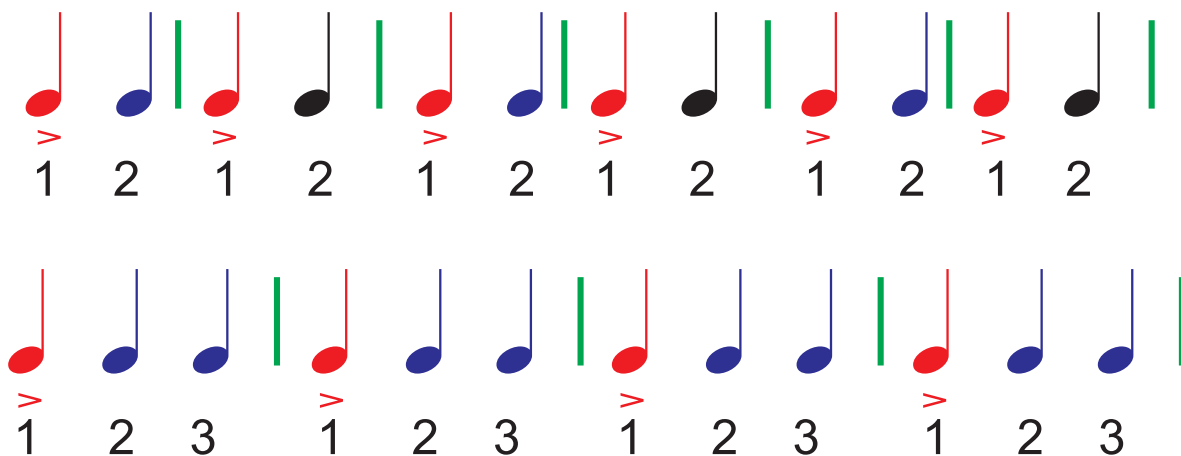

Bu chiziq **takt chizig'i** deb ataladi.





OT O'YINI

D.Omonullayeva musiqasi

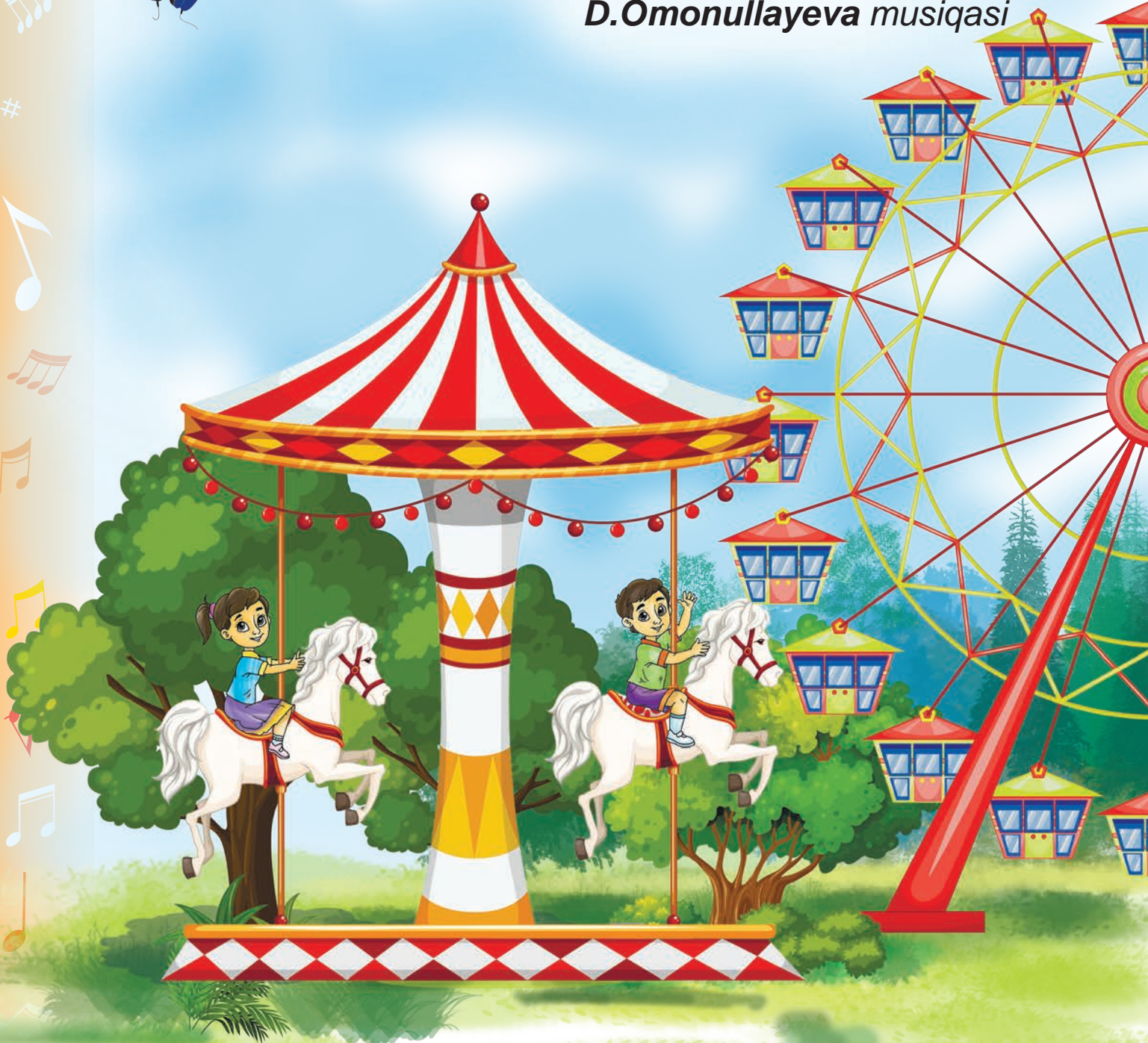



BOBOM – QAHRAMON

A. Haydarov she'ri va musiqasi

Bobom – qahramon,
Urushda bo'lgan.
Yovlar ustidan
G'alaba qilgan.

Naqarot:

Qahramon, qahramon,
Bobom – qahramon.
Bobojon, doimo
Bo'ling sog'-omon.

Jang-u jadalda
Quchgan zafarlar.
Ko'ksida to'la
Orden-medallar.

Naqarot.

E'zozda doim
Bobomday mardlar.
Elin asragan
Botir askarlar.

Naqarot.

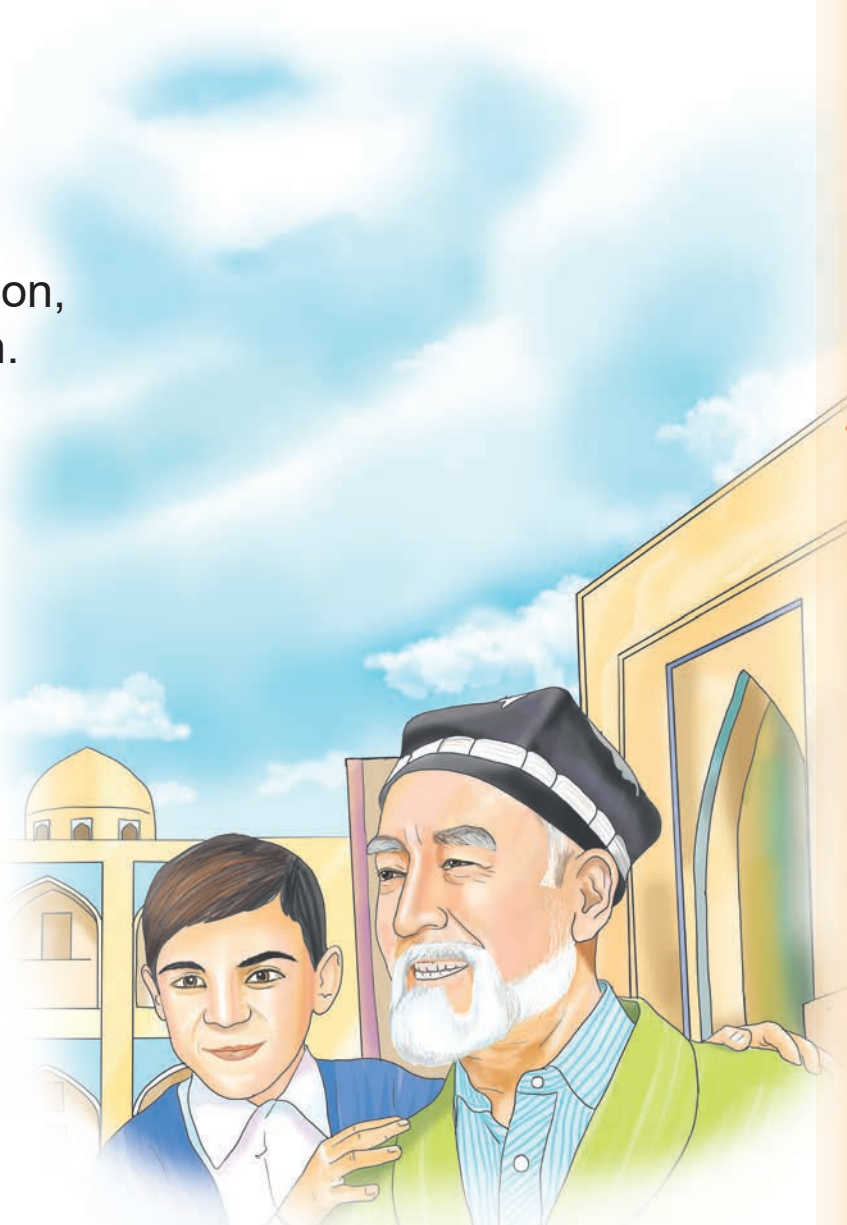
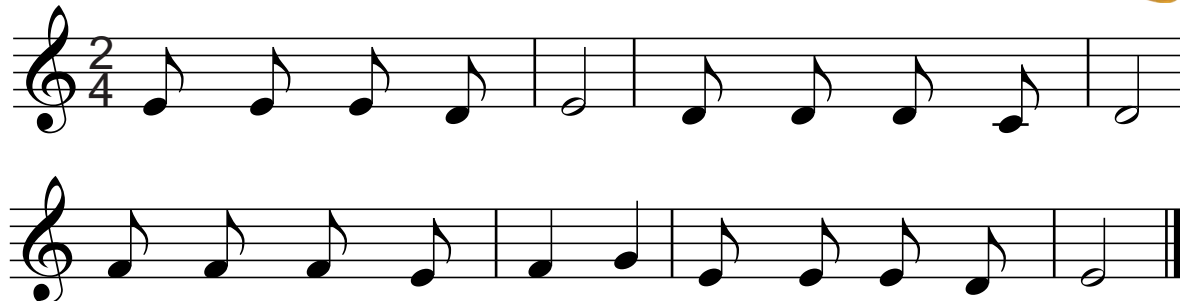

3–4-darslar

O‘LCHOV

Musiqada o‘lchov taktning sig‘imini, ya’ni bitta taktga nechta nota joylashishini ko‘rsatadi.

U biri ikkinchisining ustida joylashgan ikkita raqam ko‘rinishida yoziladi.

Quyidagi namunada ana shunday yozuvlarni ko‘rishingiz mumkin:

2	3	4
4	4	4

2 — taktdagi hissa (ikki)
 4 — har bir hissaning uzunligi (chorak)

Musiqqa asarining o‘lchovi musiqiy kalitdan keyin qo‘yiladi.

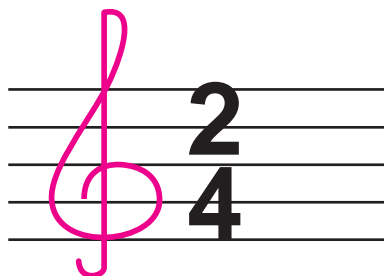

SANASHNI O'RGANAMIZ

2
4

1, 2

1 2

1 2

3
4

1, 2

1 2

1 2

3

3

3

4
4

1, 2, 3, 4

1, 2

1 2

1 2 3 4

1 2 3 4

1 2 3 4



QASHQARCHA

O'zbek xalq kuyi

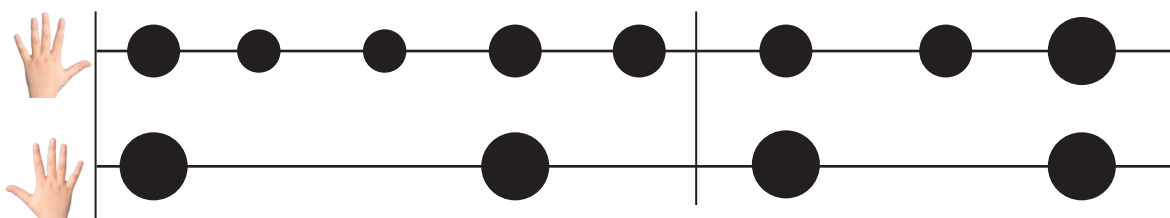

?! "Qashqarcha" kuyi ritmini ikki guruhga bo'linib ijro eting.

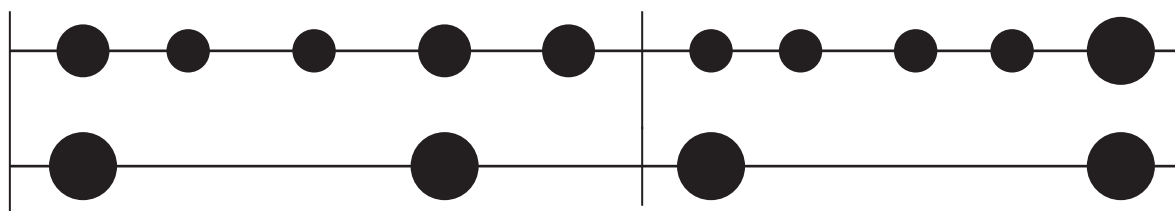

UXLAB TURDIM



I. Muslim she'ri

Oyijonim,
Bugun yaxshi
Uxlab turdim.

Juda qiziq,
Juda shirin
Tushlar ko'rdim.

F. Nazarov musiqasi

Yumshoq yostiq,
Issiq ko'rpa –
Rohat, rohat.

O'z vaqtida
Uyg'onishni
Qildim odat.

Naqarot:

Sizga, sizga assalom!
Hammangizga assalom!



“Uxlab turdim” qo'shig'ining ritmik tasvirini doirachalar bilan ifodalaymiz.

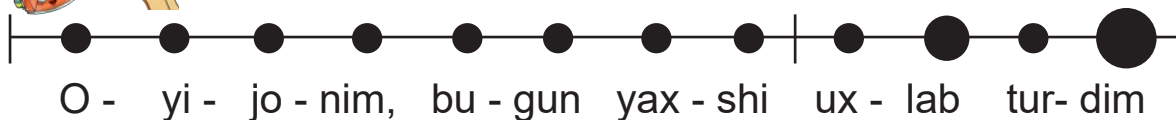

Doirachalarni turli uzunlikdagi notalar bilan almashtiramiz.

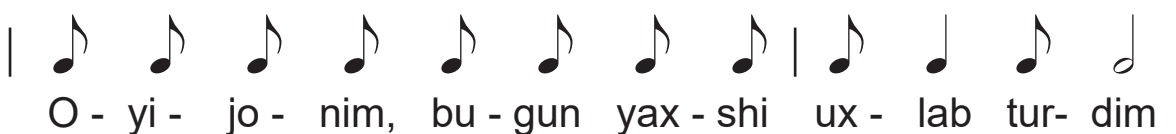

Qo'shiqni notaga qarab kuylaymiz.



O - yi - jo - nim, bu - gun yax - shi ux - lab tur - dim



5–6-darslar

REPRIZA

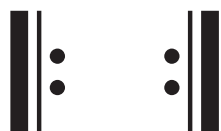

Kuyning asosiy qismi
Yana yangraydi takror.
Bu qism chekkasida
Repriza belgisi bor.

D. Omonullayev

Musiqqa asarining biror qismi takrorlanishini bildiruvchi belgi “**repriza**” deb ataladi.

Ushbu rasmda qizil hoshiya bilan ajratilgan repriza belgisini ko‘rib turibsiz.

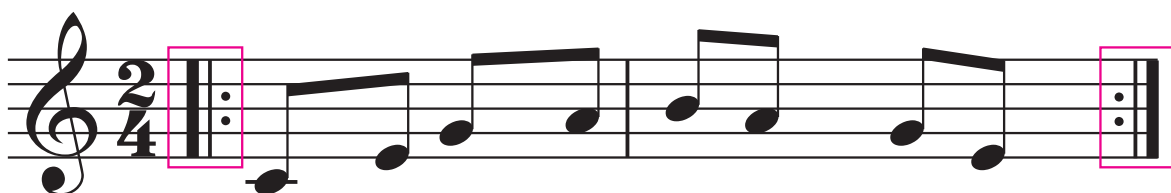

Musiqqa asarining ushbu ikki nuqtali belgi – repriza belgisi orasidagi qismi takrorlanadi.



Dan- ga -sa bo‘l-mang, danga-sa - a.



An-jir qi-ziq-dir o‘ - zi, lekin bit-ta - dir ko‘ - zi.



Repriza belgisi bilan takt chizig‘i bir-biridan qanday farq qiladi?



VALS

P. Chaykovskiy musiqasi
“Bolalar albomi”dan

Vals juft-juft bo‘lib, tekis aylana harakatlar bilan ijro etiladigan raqs. U asosan katta raqs kechalarida ijro etiladi.



NAVRO‘ZIM – SHO‘X SOZIM



H. Rahmat she‘ri
N. Norxo‘jayev musiqasi

Navro‘z keldi, Navro‘z keldi kulib-kulib,
Bog‘-u dalam, bog‘-u dalam gulga to‘lib,
Qushlar sayrar juft-juft bo‘lib.

Naqarot:

Navro‘zim – o‘z so‘zim, shod ovozim,
Shod ovozim, sho‘x sozim.

Navro‘zimni sevar jahon, sevar jahon,
Ona diyor, hur guliston, hur guliston,
Kundan kunga zavqli davron.

Naqarot:

Navro‘zim – o‘z so‘zim, shod ovozim,
Shod ovozim, sho‘x sozim.

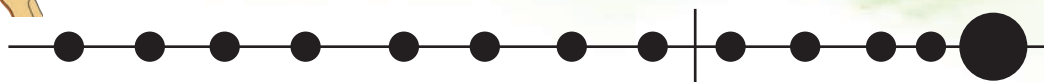

Qo‘shiq ritmini nota matni bilan taqqoslang.



Nav-ro‘z kel - di, nav- ro‘z kel - di ku- lib ku - lib



LAD: MAJOR VA MINOR

Musiqiy tovushlar o‘zaro kelishib yashaydilar. Har birining o‘z o‘rni va joyi bor. Musiqiy lad – bu o‘zaro kelishuvda, ya’ni muayyan ketma-ketlikda joylashgan tovushlar guruhi.

Musiqada ladlar juda ko‘p. Ularning orasida eng asosiysi ikkita: major va minor.

Major – bu yorqin jaranglagan musiqa, quvnoqlik, tetiklik va xursandchilik kuylarining asosi.

Minor – ma’yus va o‘ychan kuylarning asosi.



Major ladidagi kuy parchasini tinglang:



Minor ladidagi kuy parchasini tinglang:



MAJOR VA MINOR

Musiqiy mamlakatda
Bor ikki aka-uka.

Major – quvnoq va shodon,
Tetik, bardam, sho‘x-xandon.

Ikkinchi bola – **Minor**,
U g‘amgin tovushqator.

Ma’yus qo‘shiq aytadi,
Bizni o‘yga soladi.

Major va **Minor** birdam,
Ahil yashashar har dam.





TOREADOR MARSHI

J. Bize musiqasi

Marsh – saf tortib yurishda ijro etiladigan tantanali musiqiy asar.



Turgan joyingizda kuyga mos qadam tashlang.

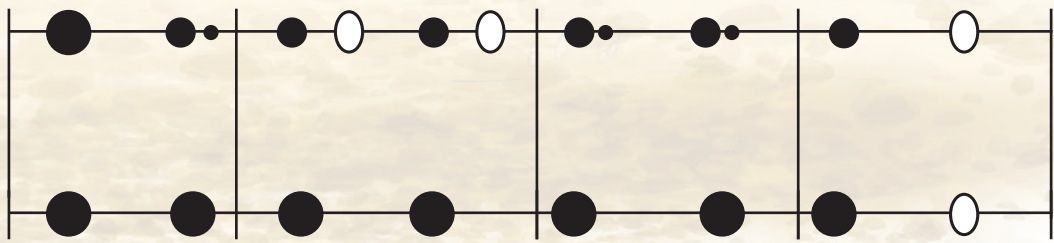



ZAG'IZG'ON



P. Mo'min she'ri

D. Omonullayeva musiqasi

Zag'izg'on, zag'izg'on,
Uchag'on zag'izg'on.
Choponi oladir,
Qarg'aga xoladir.



Tomlarda qaqillar,
Tomog'i taqillar.
Ko'zlari alanglar,
Och qolsa, yalanglar.

Aytayin to'g'risin,
U sovun o'g'risi.
Zag'izg'on, zag'izg'on,
Qochag'on zag'izg'on.



Za- g'iz-g'on, za- g'iz- g'on, u-cha-g'on za- g'iz - g'on.

Za- g'iz-g'on za- g'iz- g'on, u-cha-g'on za- g'iz - g'on.

MUSIQALI REBUSLAR

Rebuslar sizga bir olam zavq hadya qiluvchi, fikrlashga o'rgatuvchi, lug'at boyligini oshiruvchi, diqqatliroq bo'lishga undovchi o'yin turidir. Musiqiy rebuslarni yechish uchun shunchaki **do, re, mi, fa, sol, Iya, si** notalarining nota yo'lida joylashuvini bilish kifoya.

Notalarni aniqlang va yashirilgan so'zlarni topib, musiqali rebusni to'g'ri o'qing.

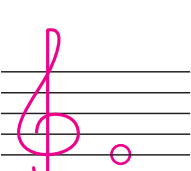
 – birinchi nota  z

 –  buslar yecha  z.

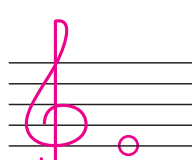
 –  yovlaydi mushuk,

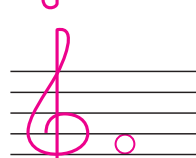
 –  zoga ucha  z.

 –  va masala,

 – yangraydi ashula.

 – yettinchi nota  z,

Yana  ga qayta  z.



YUGURISH

S. Abramova musiqasi

Kuy harakati aks ettirilgan quyidagi namunalardan qaysi biri S.Abramovaning “Yugurish” kuyiga mos keladi?



ISMALOQ



P. Mo'min she'ri

D. Omonullayeva musiqasi

Ismaloq zo'r o'simlik,
Bargchalari ko'rimlik.
Bizning uyda ismaloq
O'sib yotar shapaloq.

Barglarini avaylab
Terib berdik ataylab.
Somsa qilsalar oyim,
Maza qilamiz doim.



?! "Ismaloq" kuyining ritmik ifodasini nota matni bilan taqqoslang.
Notaga qarab kuylang.

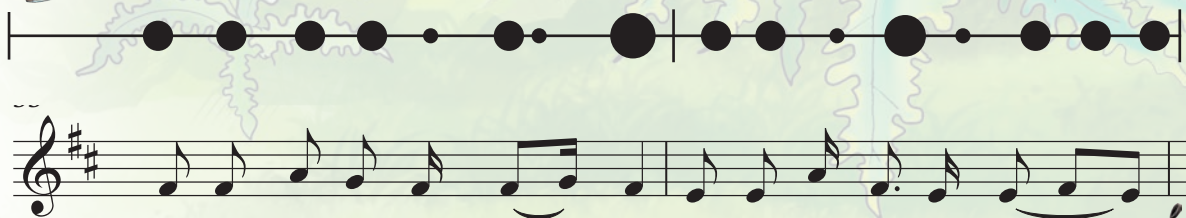

4-BOB BOLALAR BASTAKOR VA KOMPOZITORLARI

Shermat Yormatov

Bolalarning sevimli bastakori Shermat Yormatov 1939-yili Farg'ona viloyatida tug'ilgan. Ko'p yillardan beri yosh qo'shiqsevarlarga san'at sirlarini o'rgatib kelmoqda. Ustoz bastakor tashkil qilgan "Bulbulcha" bolalar ansambli nafaqat respublikada, balki ko'plab chet mamlakatlarda o'zbek bolalar qo'shiqchilik san'atini targ'ib qilmoqda. Shermat Yormatov "Oymomojon rom bo'ldi", "G'ildiragim", "Sog'lom avlod qo'shig'i", "Oy bo'lamiz, toy bo'lamiz" kabi o'nlab qo'shiqlarni yaratgan.

O'zbekiston xalq artisti Shermat Yormatov bolalar qo'shiqchiligini rivojlantirishga qo'shgan hissasi uchun "Sog'lom avlod" ordeni bilan mukofotlangan.



O'YNADIK, HECH TO'YMADIK

P. Mo'min she'ri
Sh. Yormatov musiqasi

Bag'ri ko'm-ko'k dalalar,
Gullari ko'p dalalar.
Qarang, juda keng ekan,
Bir olamga teng ekan.

Naqarot:
Dalalarda o'ynadik,
Hech o'yinga to'ymadik.

Oftob bizni ko'rardi,
O'ynaymi, deb so'rardi.
Shamol asta yelardi,
Davramizga kelardi.

Naqarot.



Bag'-ri ko'm-ko'k da-la-lar, da-la-lar.



SOG'LOM AVLOD QO'SHIG'I

T. Bahromov she'ri

Sh. Yormatov musiqasi

Quyosh bo'lsin, oy bo'lsin,
O'zbekiston boy bo'lsin.
Menga atlas, ukamga
Gijinglagan toy bo'lsin.

O'saversin bo'yimiz,
Tenglik – orzu-o'yimiz.
Bu dunyoda bor bo'lsin
O'zbekiston – uyimiz.

Naqarot:

Dadam yuzga kirsinlar,
Ayam yuzga kirsinlar.
Bizlar yuzga kirganda
Yonimizda yursinlar.

Naqarot.

?! “Sog'lom avlod qo'shig'i” ritmik tasvirini nota matni bilan taqqoslang.

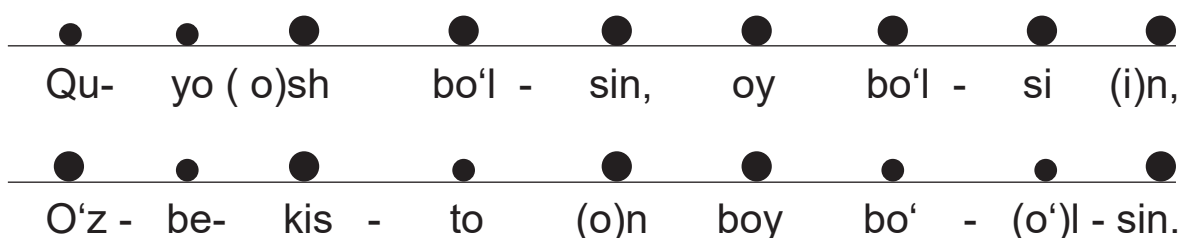



Nadim Norxo'jayev

Bolalarning sevimli kompozitori Nadim Norxo'jayev 1947-yili Toshkent shahrida ziyolilar oilasida tug'ilgan. U bolalar qo'shiqchilik san'ati

rivojiga katta hissa qo'shgan kompozitorlardan biridir. Zamondosh shoirlar bilan hamkorlikda bolalar uchun 200 dan ortiq qo'shiqlar yaratgan.

Nadim Norxo'jayevning “Qor”, “Navro'zim – sho'x sozim”, “Chamandagi gullarmiz”, “Yaxshi bola”, “Gullar – manim kulganim”, “O'zbekimdan aylanay”, “Hakkalar” kabi yuzlab qo'shiqlarini bolalar sevib kuylaydilar.

O'zbekiston Respublikasi san'at arbobi, O'zbekistonda xizmat ko'rsatgan madaniyat xodimi, O'zbekiston davlat konservatoriyasi professori N. Norxo'jayev o'zining jozibali musiqiy asarlari, ayniqsa, estrada va bolalar uchun yaratgan qo'shiqlari bilan el-yurt hurmatiga sazovor bo'lgan.



CHINNIGUL

Qambar Ota she'ri

N. Norxo'jayev musiqasi



Yonib turgan chinnigul,
Yoqtiradi har ko'ngil.
Senga shaydo har bir dil,
Chinnigul, chinnigul.

Gul tanlagan ko'zlarga,
Dildan chiqqan so'zlarga,
Kulib chiqqan yuzlarga
Yarashiqsan, chinnigul.

Oymisan yo kunmi, gul?
Mehring elga chinmi, gul?
Uch-to'rt dona chinnigul
Quvonchlarga ochar yo'l.

Sen eng nodir sovg'asan,
Go'zallikda tanhosan.
Olqishlarga ravosan,
Ardoqligim, chinnigul.



Yo- nib tur - gan chin- ni - i gu - u - l

HAKKALAR

N. Orifjonov she'ri

N. Norxo'jayev musiqasi

Ola qanot hakkalar,
Shoxdan shoxga qo'nasiz.
"Chig'ir-chig'lab" nimanidir
Izlab topgan bo'lasiz.

Teraklarning uchidan
Sizga boqar polapon.
Qamishzorlar ichidan
Unga qarab qolaman.

Shoshqaloqlab tumshug'in
Siz tomonga tutadi.
Hali yosh, yo'l-yo'rig'in
Topmay, najot kutadi.

Uni boqish farzingiz,
Yurmang muncha hakkalab.
Boshqalardan farqingiz –
Yengiltaksiz, hakkalar.

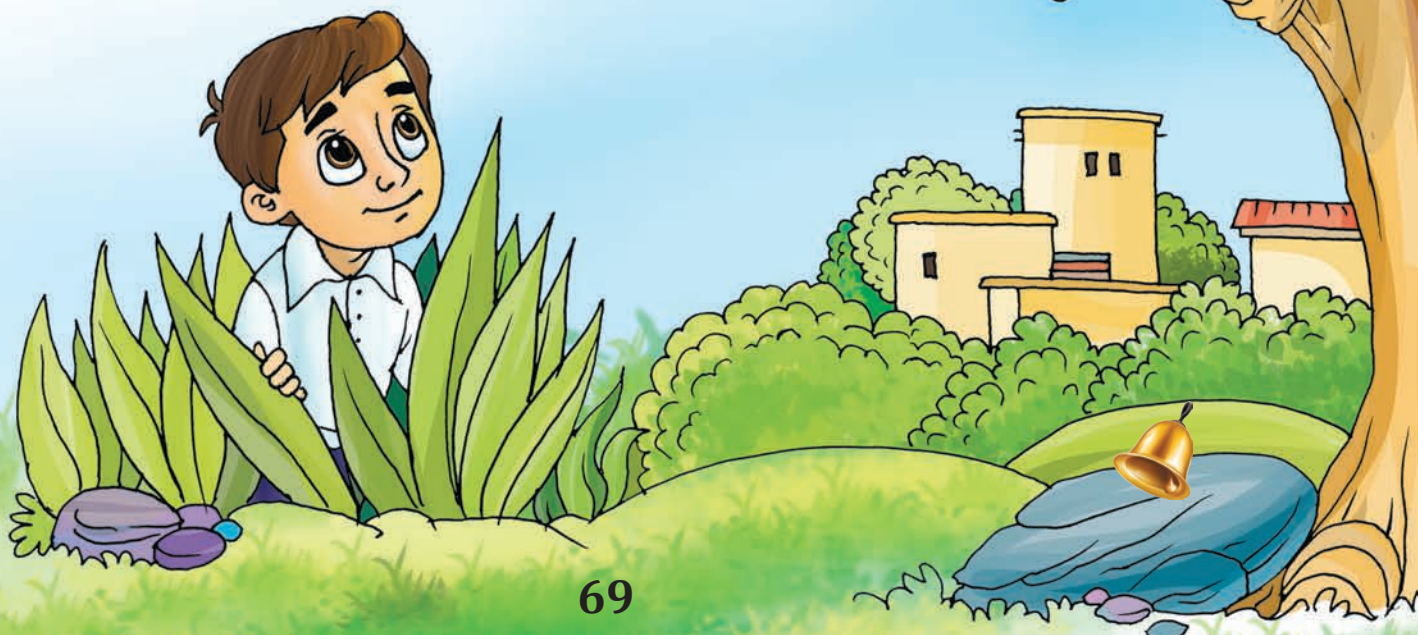

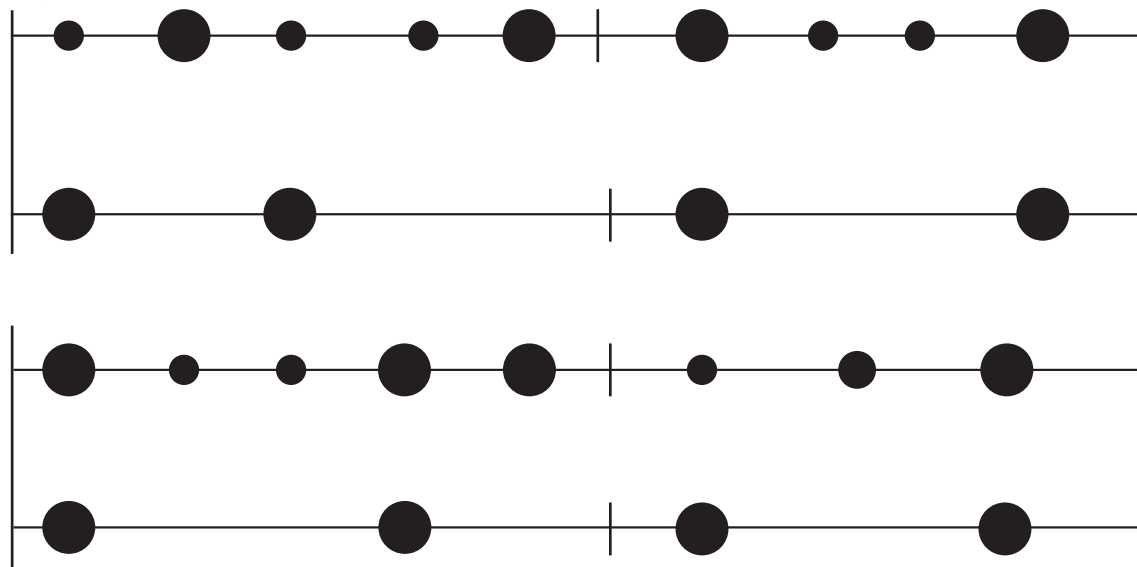

?! “Hakkalar” qo‘shig‘ini bolalar cholg‘ulari jo‘rligida ifodali kuylang.
Berilgan namunadagi eng pastki va eng yuqori tovushlarni aniqlang.

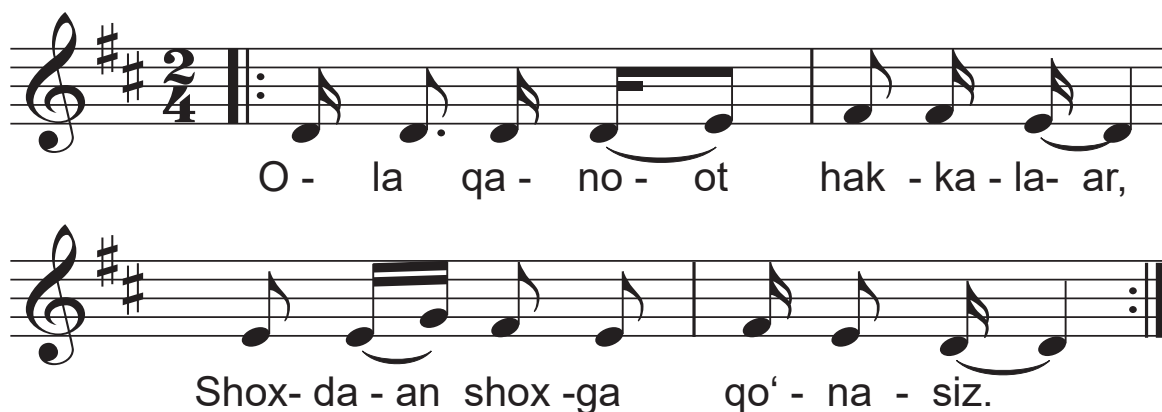

Berilgan mashqdagi chorak va yarim notalarni “bum”, nimchorak notalarni esa “bak” bo‘g‘inlari bilan aytib, chapak yoki bolalar cholg‘ularida jo‘r bo‘ling.

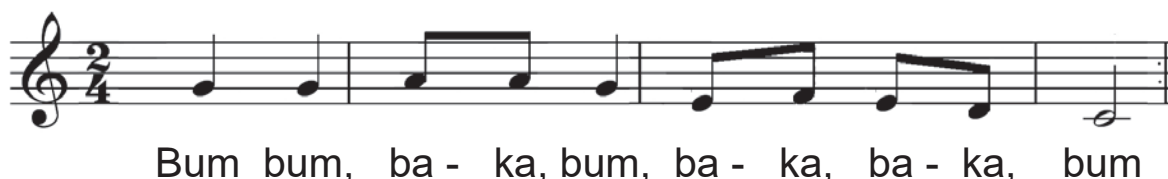



Dilorom Omonullayeva

Bolalarning sevimli kompozitori Dilorom Omonullayeva 1959-yili Toshkent shahrida musiqachilar oilasida tug‘ilgan.

Serqirra ijodining ko‘p qismi bolalarga bag‘ishlangan. Dilorom Omonullayevaning “Alifbe qo‘shig‘i”, “Humo qushim”, “Aziz bo‘ston – O‘zbekiston”, “O‘zbek elim – bek elim”, “Diloromning qo‘shig‘i”, “Buvijon” kabi ko‘plab rang-barang qo‘shiqlari hamda “Ot o‘yini”, “Qo‘g‘irchoqlar bilan raqs” kabi ko‘plab bolalar uchun yaratilgan kuylari ham o‘quvchi-yoshlar orasida mashhurdir.

Dilorom Omonullayeva O‘zbekiston musiqa madaniyati rivojiga qo‘shgan hissasi uchun “O‘zbekistonda xizmat ko‘rsatgan madaniyat xodimi”, “O‘zbekiston Respublikasi san‘at arbobi” faxriy unvonlari bilan taqdirlangan.

QO'G'IRCHOQLAR BILAN RAQS



D. Omonullayeva musiqasi



“Qo'g'irchoqlar bilan raqs” kuyini diqqat bilan tinglab, unga mos raqs harakatlarini o'ylab toping. Kuyini notalarga qarab tinglang.



BUVIJON



Y. Suyunov she'ri

D. Omonullayeva musiqasi

Menga tengsiz mehri bor,
So'zlarida sehri bor.
Ertak aytib tolmaydi,
Erkalatib hormaydi.

Naqarot:

Buvijonim, buvijon,
Mehribonim – buvijon.
Onaginam onasi,
Sho'x zabonim – buvijon!

Ko'rolmasa bir kuni,
Uxlay olmaydi tuni.
Ko'ngli sog'inchga to'lib,
Izlar parvona bo'lib.

Baxtinga omon yuring,
Xush-xandon davron suring.
Ko'zingiz namlanmasin,
Dilingiz g'amlanmasin.

Naqarot.



Ikki guruhga bo'linib, ijro eting.
Notaga qarab kuylang.



● ● ● ● ● ● ● ●	○ ○ ○ ○ ○ ○ ○ ○
Bu- vi - jo - nim, bu - vi - jon,	
● ● ● ● ● ● ● ●	○ ○ ○ ○ ○ ○ ○ ○
Meh- ri- bo- nim bu - vi - jon.	
● ● ● ● ● ● ● ●	○ ○ ○ ○ ○ ○ ○ ○



7–8-darslar

MUSIQA IJODKORLARI

Rasmga diqqat bilan qarang. Unda shoir, kompozitor, xonanda, sozanda kabi ijodkorlar tasvirlangan. Havodagi sharlarda esa ijodkorlarning asosiy ijod vositalarining nomlari yozilgan.



?! Qaysi sharni qaysi ijodkorga bergan bo'lardingiz? Nima uchun?



KAPALAK VA KAMALAK

N. Narzullayev she'ri

N. Norxo'jayev musiqasi

Gulga qo'nib kapalak,
Qanotini o'ynatar.
Ko'kda chaqnab kamalak,
Yetti rangda raqs etar.

Naqarot:

Kapalakjon, kapalak,
Sen ham menday sho'xmisan?
Uyda yolg'iz o'tirib,
Zerikishga yo'qmisan?





HANDALAK

P. Mo'min she'ri

Naqarot:

Handalak, handalak
Pishgan edi.
Tarqaldi, tarqaldi
Har yon hidi.

Egnida
Beqasam to'n,
Tikilibdi
Juda jo'n.

D. Omonullayeva musiqasi

Har bittamiz
Pushtadan
Olib chiqdik
Uchtadan.



Naqarot.

Bittadan
So'yib yedik.
Rosayam
To'yib yedik.

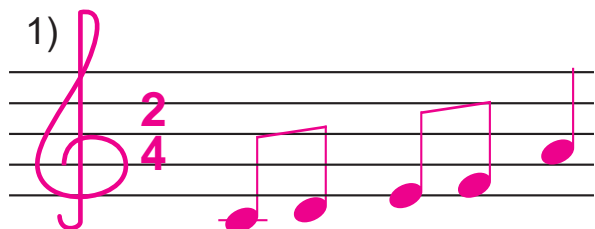

MUSTAHKAMLASH UCHUN SAVOL VA TOPSHIRIQLAR

1. Qaysi namunada 2/4 o'lchovi to'g'ri qo'yilgan?

1)  2) 

2.  ?

3. 

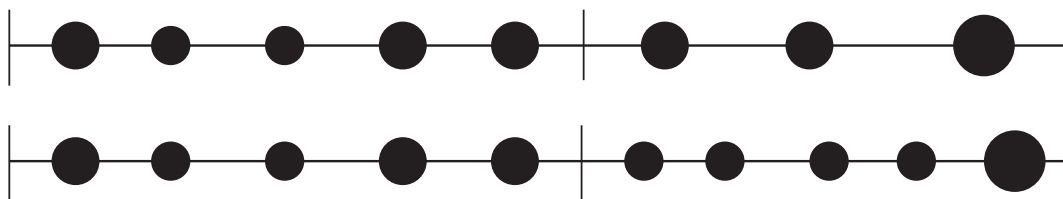

4.  ?

5. Berilgan namunalardan qaysi biri S. Abramovning "Yugurish" kuyiga mos keladi?

1) 

2) 

3) 



6. “Uxlab turdim” qo’shig’i ritmini chapak yoki bolalar cholg’ularida ifoda eting.



7. Quyida qaysi qo’shiq ritmi berilgan?

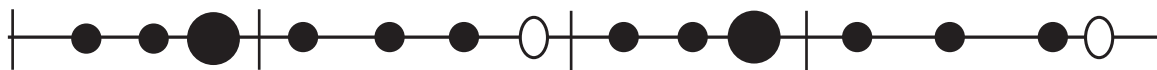

8. Suratdagi bastakorlar haqida so’zlab bering.



9. Mashq – bilimning onasi,
Top, bu notalar qaysi?



Musiqa 2-sinf [Matn]: darslik / N.Norxo'jayev [va boshq.]. – Toshkent: Respublika ta'lim markazi, 2021. – 80 b.

ISBN 978-9943-7300-3-8

UO'K 78(075.3)
KBK 74.268.53

O'quv nashri

**Nadim Norxo'jayev, Shoxista Norxo'jayeva,
Dilnoza Toshmuhamedova**

MUSIQA

*Umumiy o'rta ta'lim maktablarining
2-sinfi uchun darslik*

*Rassom Umid Sulaymonov
Muharrir Xurshidbek Ibrohimov
Badiiy muharrir Sarvar Farmonov
Texnik muharrir Akmal Sulaymonov
Dizayner Dilmurod Mulla-Axunov
Sahifalovchi Alimardon Aqilov
Musahhah Mohinur Ablahakimova*

Bosishga 17.08.2021-yilda ruxsat etildi. Bichimi 60x84 $\frac{1}{8}$.
Arial garniturasini. Kegli 16 shponli. Ofset bosma.
Shartli bosma tabog'i 9,30. Nashriyot-hisob tabog'i 8,25.
Adadi — nuxsa. Buyurtma № ____.

Ijaraga beriladigan darslik holatini ko'rsatuvchi jadval

№	O'quvchining ismi va familiyasi	O'quv yili	Darslikning olingandagi holati	Sinf rahbarining imzosi	Darslikning topshirilgandagi holati	Sinf rahbarining imzosi
1.						
2.						
3.						
4.						
5.						
6.						

Darslik ijaraga berilib, o'quv yili yakunida qaytarib olinganda yuqoridagi jadval sinf rahbarlari tomonidan quyidagi baholash mezonlariga asosan to'ldiriladi:

Yangi	Darslikning birinchi marta foydalanishga berilgandagi holati.
Yaxshi	Muqova butun, darslikning asosiy qismidan ajralmagan. Barcha varaqlari bor, yirtilmagan, ko'chmagan, betlarida yozuv va chiziqlar yo'q.
Qoniqarli	Muqova ezilgan, birmuncha chizilib, chetlari yedirilgan, darslikning asosiy qismidan ajralish holati bor, lekin qoniqarli ta'mirlangan. Ko'chgan varaqlari qayta joylangan, ayrim betlariga chizilgan.
Qoniqarsiz	Muqova yirtilgan, ustiga chizilgan, asosiy qismidan ajralgan yoki butunlay yo'q, qoniqarsiz ta'mirlangan. Betlari yirtilgan, varaqlari yetishmaydi, chizib, bo'yab tashlangan. Darslikni tiklab bo'lmaydi.